

Operating Manual

Basic Line Module

BV 032-0X-000

1- Spindle

Revision history

Revision	Date	Comment	Chapter
01	02.08.2021	Creation	All
02	21.02.2022	Module replacement / temperature sensor	5.5 / 9.1.3
03	29.04.2022	Addition of modul variants	3 till 9

Service

If you have any technical questions, please contact the following address:

ToolDrives GmbH & Co. KG

Königlicher Wald 6

D-33142 Büren

Tel.: +49 2951 70798 50

Email: info@tooldrives.de

This documentation is protected by copyright.

ToolDrives GmbH & Co. KG reserves all rights, including those of photomechanical reproduction, duplication and distribution using special processes (e.g. data processing, data carriers and data networks).

Content and technical changes reserved.

CONTENTS

REVISION HISTORY	2
SERVICE	2
1. ABOUT THIS MANUAL	5
1.1 GENERAL.....	5
1.2 SAFETY SYMBOLS.....	5
2. SAFETY	6
2.1 GENERAL INFORMATION	6
2.2 EC - LOW VOLTAGE DIRECTIVE.....	6
2.3 DANGERS	6
2.4 INTENDED USE	6
2.5 REASONABLY FORESEEABLE MISUSE	7
2.6 WARRANTY AND LIABILITY	7
2.7 GENERAL SAFETY INSTRUCTIONS	7
2.8 SAFETY LABEL ON BASIC MODULE.....	8
3. DESCRIPTION OF THE BASIC MODULE	9
3.1 IDENTIFICATION PLATE	9
3.2 TYPE CODE	10
3.3 ORDER CODE.....	10
3.4 GENERAL DATA	10
4. TRANSPORT AND STORAGE	11
4.1 SCOPE OF DELIVERY.....	11
4.2 OPTIONAL ACCESSORIES	11
4.3 PACKAGING	11
4.4 TRANSPORT	11
4.5 STORAGE	11
5. ASSEMBLY	12
5.1 PREPARATIONS	12
5.2 MANUFACTURE AND INSTALL THE MOUNTING FRAME.....	12
5.3 PREPARE SUCTION	13
5.4 MOUNT THE SUCTION SYSTEM.....	13
5.5 REPLACING THE BASE MODULE	14
5.6 INSTALL ELECTRICAL CONNECTORS (A)	15
5.7 CONNECT PNEUMATICS (SEALING AIR) (A)	16
6. COMMISSIONING AND OPERATION	16
6.1 EMC-MEASUREMENTS	18
6.2 SET UP AND CHANGE TOOLS.....	18
6.2.1 ER11 (collet) tool holder (DIN ISO 15488)	19
6.2.2 High Speed Weldon tool holder	21
6.2.3 Square drive tool holder.....	22
6.3 DIRECTION OF ROTATION OF THE MOTOR SPINDLES.....	22
7. MAINTENANCE AND DISPOSAL	23
7.1 MAINTENANCE WORK.....	23
7.1.1 Ball bearings	23
7.1.2 Visual inspection	24
7.1.3 Cleaning.....	24
7.2 CHECK THE TIGHTENING TORQUES OF THE FASTENING SCREWS.....	24

7.3	CHECK THE TIGHTENING TORQUE OF THE TOOL.....	25
7.3.4	<i>ER11 (collet) tightening torque check</i>	26
7.3.5	<i>High Speed Weldon tightening torque check</i>	26
7.4	COMMISSIONING AFTER MAINTENANCE	26
7.5	MAINTENANCE SCHEDULE.....	27
7.6	DISPOSAL	27
7.7	SPAREPARTS AC-CODES	27
8.	INTERRUPTIONS.....	28
8.1	IN GENERAL	28
8.2	ERRORS - POSSIBLE CAUSES - REMEDIES	28
9.	APPENDIX.....	29
9.1	TECHNICAL DATA.....	29
9.1.1	<i>Sealing air >(specification)</i>	29
9.1.2	<i>Motor data</i>	30
9.1.3	<i>Pin assignment motor connector</i>	31
9.1.4	<i>Motor protection characteristic (KTY) Silicon temperature sensor KTY84-130</i>	32
9.1.5	<i>Pin assignment of signal connector M17 – 12-pin (on Basic Module side)</i>	33
9.1.6	<i>Specification Encoder</i>	34
9.2	DIMENSION SHEETS.....	35
9.2.1	<i>Dimension sheet with one motor spindle</i>	35
9.2.2	<i>Dimension sheet with gear and square drive</i>	36
9.2.3	<i>Dimension sheet suction</i>	37
9.2.4	<i>Dimension sheet schematic representation of the drill length</i>	38
10.	DECLARATION OF CONFOMITY	39

1. About this manual

1.1 General

- ▶ These instructions are intended for all people who work with the Basic Module. During their work, they must have the operating instructions available and observe the information and notes that apply to them.
- ▶ These instructions help you to work safely with the "Basic Module" of the Module Basic Line. It contains safety instructions that you must observe.
- ▶ The operating instructions must always be complete and in a perfectly legible condition.
- ▶ If supplementary sheets (e.g. for special applications) are enclosed with these instructions, the information contained therein is valid. Contradicting information in this manual is therefore invalid.

The original of this manual was created in German, all other language versions are Translations of these instructions.

1.2 Safety symbols

The following safety symbols are used to draw your attention to dangers, prohibitions and important information:



Danger!

Danger of personal injury from dangerous electrical voltage.

Indicates an imminent danger that can result in death or serious injuries if appropriate actions are not taken.



Danger!

Danger of personal injury from a general source of danger. Indicates an imminent danger that can result in death or serious injuries if appropriate actions are not taken.



Stop!

Risk of property damage.

Indicates a possible danger that could result in property damage if the corresponding actions are not taken.



Hot surface

Risk of burns.

Indicates possible burns when touched with the bare hand.



Information

Important information.

Instructions for trouble-free function and useful tip for easy handling.

2. Safety

2.1 General Information

- ▶ The Basic Module has dangerous, electrical parts, rotating parts and hot surfaces during operation.
- ▶ All work on transport, connection, commissioning and maintenance must be carried out by qualified, responsible specialist personnel who have read and understood these operating instructions. Improper behavior can cause bad personal injury and property damage.
- ▶ The safety instructions and the rules and regulations applicable to the place of use / country of use must be observed. In addition to the safety instructions, the generally applicable legal and other rules and regulations for accident prevention (e.g. personal protective equipment) and environmental protection must be followed.

2.2 EC - Low Voltage Directive

The Basic Module was built in accordance with directive 2006/95 / EC. The electrical installation must be carried out in accordance with the relevant regulations (e.g. cable cross-sections, protection).

Compliance with the requirements for an entire system is the responsibility of the manufacturer of the complete system.

The declaration of conformity can be found in the appendix chap. 10th.

2.3 Dangers

The Base Module has been developed and built in accordance with the current state of the art and recognized safety regulations. It may only be used and operated in a technically perfect condition.



Read the information about the general safety instructions before starting work (see chapter 2.7 "General safety instructions").

2.4 Intended use

The Basic Module

- ▶ is intended for use in commercial machines and must **not be used outdoors**.
- ▶ it is only intended **for use in machining centers** for stationary and pass trough technology and is used for the production of holes or saw cuts in wood materials, wood composite materials and other materials in dry machining.
- ▶ may only be operated with the tool holder mounted on delivery and **only with the correct phase** (counter-clockwise rotating field), see chapter 6.3 "Direction of rotation of the motor spindles".
- ▶ should be operated on the sensorless servo controller (Dual Servo Controller - DSC) type ToolDrives (Control Box). Use on other controllers requires the recommendation or approval of **ToolDrives GmbH & Co. KG**, otherwise the warranty will expire.

2.5 Reasonably foreseeable misuse

- ▶ Any use that exceeds the maximum permissible values in the technical data, see chapter 9.1 "Technical data", is considered improper and is therefore prohibited.
- ▶ The Basic Module must not be operated in potentially explosive areas.
- ▶ For safe operation: the necessary protective devices must be in place, properly installed and fully functional. They may not be removed, changed, bypassed or rendered ineffective.
- ▶ In case of emergency stop situations, power supply malfunctions and / or damage to the electrical equipment, the Basic Module has to
 - be switched off immediately,
 - secured against uncontrolled restart and
 - secured against uncontrolled overrun.

2.6 Warranty and liability

Warranty and liability claims for personal injury or property damage are excluded if

- ▶ Failure to observe the instructions for transport and storage;
 - ▶ improper use (misuse);
 - ▶ improper or not performed maintenance or repair work;
 - ▶ opening the Basic Module;
 - ▶ improper assembly / disassembly or improper operation;
 - ▶ operation of the Basic Module with defective protective devices;
 - ▶ operation of a heavily dirt Basic Module;
- ▶ changes or conversions without the written approval of **ToolDrives GmbH & Co. KG** were executed.

2.7 General safety instructions



Danger!

Faulty electrical connections or unauthorized electrical components lead to serious injuries and even death.

- Only have all electrical connection work carried out by specialist personnel.
- Replace damaged cables or plugs immediately.



Danger!

Tool movements can pull in body parts and cause serious injuries and even death.

- Do not enter the machine in which the Basic Module is installed until the machine is completely switched off.
- Secure the machine against restart and unwanted movements during assembly and maintenance work.



Danger!

Loose or overloaded screw connections can cause serious injuries or even death and / or substantial property damage.

- Use a calibrated torque wrench to assemble and check all screw connections for which a tightening torque is specified.

Cutting injuries on tool cutting tools.

- Wear protective gloves when changing tools.
- Note other tools on the machine.



Hot surface

Hot Basic Module can cause bad burns.

- Only touch the Basic Module with protective gloves or after a long switch-off time.

2.8 Safety label on Basic Module

There is a safety label on the Basic Module that warns of hot surfaces. This safety sign must **not be removed**.

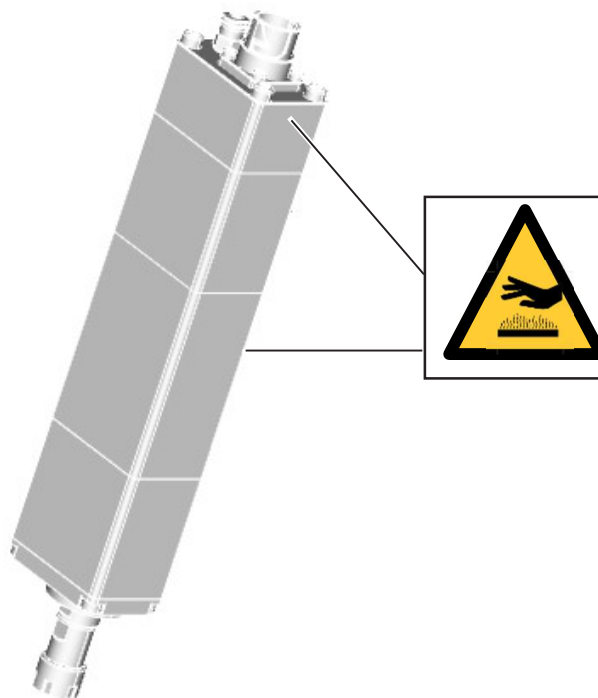

Illustration 1 Module

3. Description of the Basic Module

The basic module contains one motor spindle. This motor spindle, driven by an efficiency-optimized high-performance servo motor, can be variably controlled. The basic module has a modular design with or without an encoder and is also available with a gear.

The Basic Module with one motor spindle is designed for the following **tool holder**:

1. **ER 11 (collet)**, dimension sheet see 9.2.1 "Dimension sheet basic module with one motor "
2. **High Speed Weldon**, dimension sheet see 9.2.1 "Dimension sheet Basic Module with one motor "
3. **Square drive**, dimension sheet see 9.2.2 "Dimension sheet basic module with gear and square drive".

3.1 Identification plate

A nameplate is located on each Basic Module housing and provides detailed information about its properties.

Identification plate	Description
<p>The image shows a rectangular identification plate with the ToolDrives logo and technical data. Callouts A through L point to specific fields: A (Type code), B (Number of motor spindles), C (Max. rotational speed), D (Terminal voltage), E (Manufacturer address), F (Serial number), G (Max. power), H (Degree of protection), I (Item code), J (Direction of motor rotation), K (Max. Current), and L (Operating pressure sealing air).</p>	A Type code (see chapter 3.2)
	B Number of motor spindles
	C Max. rotational speed
	D Terminal voltage (peak value)
	E Manufacturer address
	F Serial number
	G Max. power
	H Degree of protection
	I Item code
	J Direction of motor rotation
	K Max. Current
	L Operating pressure sealing air

Tbl-1: Identification plate

3.2 Type code

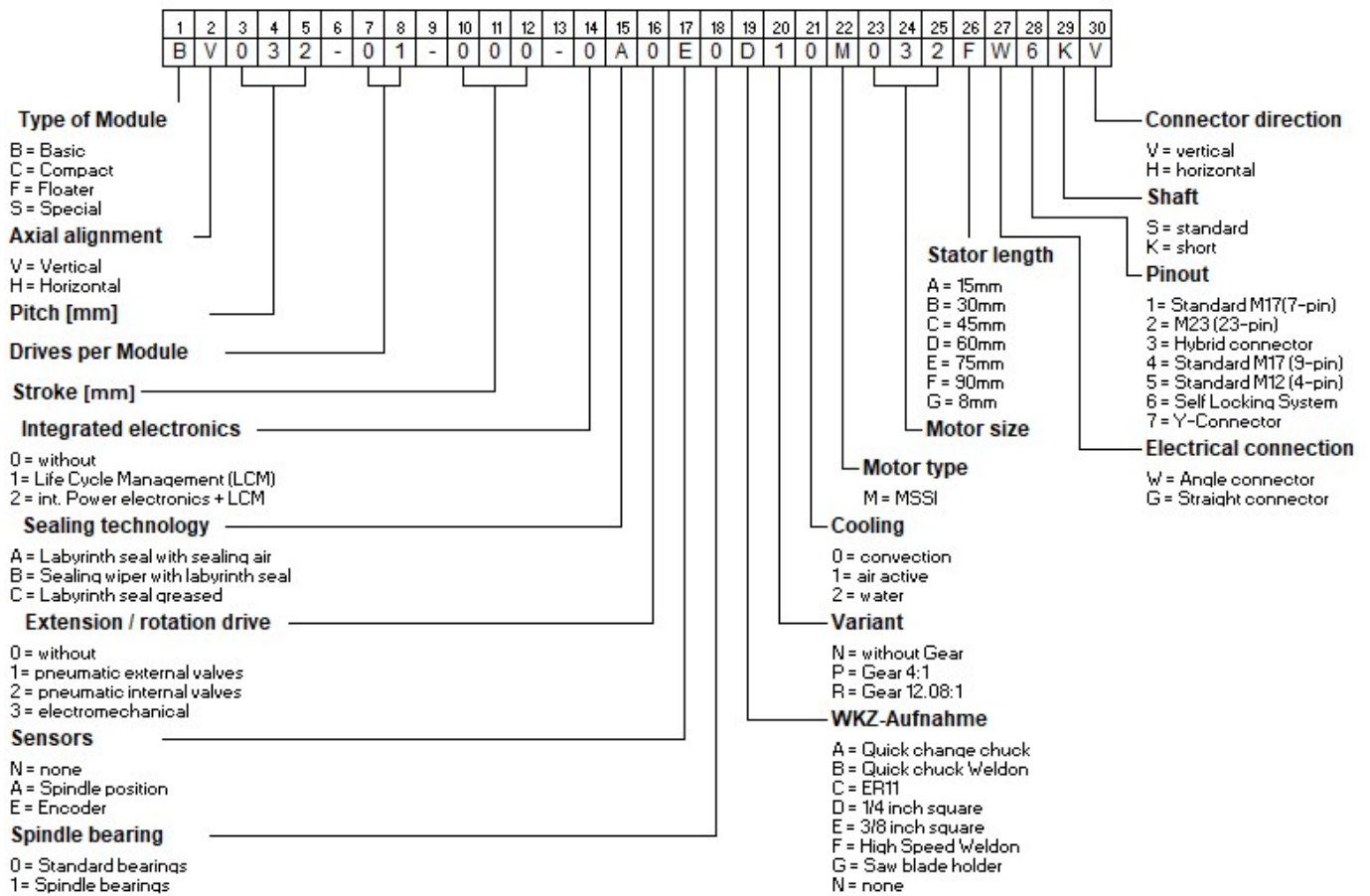

The structure and functionality of the module is described in the type code.

3.3 Order code

Part Nr.	Type code BV032-01-000-	Standard	Encoder	Gear 1-stage	Gear 2-stages	ER11	(H-S) -Weldon	1/4 inch drive	3/8 inch drive	Power connector	Pinout	Connect. direction	Special
30000314	0A0N0F00M032FG6KV	X					X			G	6	V	
30000336	0A0N0C00M032FG6KV	X				X				G	6	V	
30000384	0A0E0D20M032FG6KV	X			X			X		G	6	V	
30000390	0A0E0D20M032FW6KH		X		X			X		W	6	H	
30000394	0A0E0D10M032FW6KH		X	X				X		W	6	H	
30000395	0A0E0D10M032FW6KV		X	X				X		W	6	V	

3.4 General data

Dimensions and connection data of the Basic Module can be found in the appendix in chapter 9.1 "Technical data", "Tbl-6" and chapter 9.2 "Dimension sheets".

4. Transport and storage

4.1 Scope of delivery

Scope of delivery include:

1. Basic Module without extension.
2. Tool holder mounted.
3. Operation instructions.

Check the completeness of the delivery against the delivery note immediately after delivery. Missing parts or damage must be reported immediately to the carrier, insurance company or **ToolDrives GmbH & Co. KG** in written form.

4.2 Optional accessories

Informationen about additional accessories is available from info@tooldrives.de

4.3 Packaging

The Basic Module is delivered packed in boxes.

- ▶ Dispose of the packaging materials at the designated disposal points. Observe the applicable national regulations for disposal.

4.4 Transport



Stop!

Hard impacts, e.g. dropping or dropping it too hard can damage the Basic Module.

- Transport the Basic Module with appropriate care and avoid hard impacts.
- Put the Basic Module carefully down.

No special mode of transport is prescribed for the transport of the Basic Module.

For dimensions, see chapter 9.1 "Technical data", table "Tbl-6".

4.5 Storage

Store the Basic Module

- ▶ in a horizontal position and in a dry environment at a temperature of +5 ° C to +60 ° C,
- ▶ in an environment without condensing moisture
- ▶ in the original packaging
- ▶ maximum 2 years.

For warehouse logistics, we recommend the "first in - first out" principle.

5. Assembly

5.1 Preparations



Danger!

Incorrectly installed Basic Module can cause serious injuries.

- Mount and operate the Basic Module only in a suitable holder (mounting frame) and machine, according to the possible uses of the Basic Module.
- Comply with the required installation specifications.



Information

To reduce the exposure to dust and chips, we recommend providing an extraction system on the machine.

- Find out about the general safety instructions before starting work. (See chapter 2.7)

5.2 Manufacture and install the mounting frame



Information

Build a mounting frame or a screw-on platform. The material of the mounting frame or the screw-on platform must have a tensile / compressive strength of 400 N / mm² to ensure a secure screw connection.

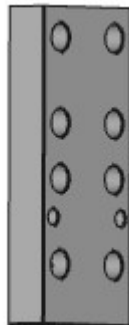
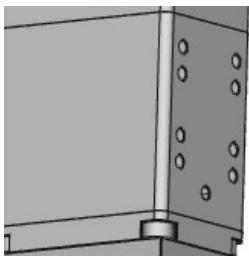

- The dimensional drawing with the drilling pattern can be found in the appendix, chapter 9.2.4. Use at least 4 out of 8 screws (M4).
- When using a base module with suction, the mounting plate must be adapted accordingly. We are happy to take over the adaptation for you, if necessary contact **ToolDrives GmbH & Co. KG**.
- Make sure that the mounting frame or the screw-on platform meets the technical requirements (e.g. rigidity, accuracy, etc.)
- Fasten the mounting frame or the screw-on platform to the base module with tightening torque:

Tightening torque of fastening screws

M4	2,4Nm ±10%
----	------------

Tbl-1: Tightening torque of fastening screws

- To secure the screw z. B. Loctite® 243 recommended.
- Check that the base module is firmly seated and is resting on the mounting frame or the screw-on platform without any gaps.

Illustration 2 mounting plate sample



Information

5.3 Prepare suction



Information

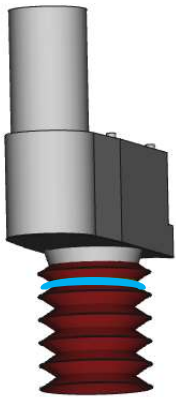

Illustration 3 mounting bellow

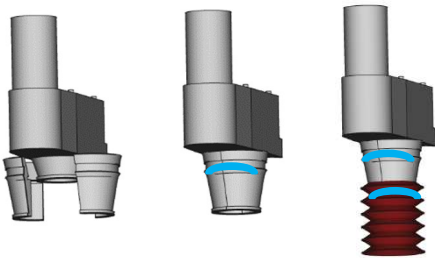

Illustration 4 mounting with a long suction

Only for base modules in use with suction.

- Clean all components with a paintbrush, brush or a clean, lint-free cloth.
- Do not use compressed air.
- If the initial order is with suction, it will be delivered already assembled.
- When retrofitting, push the bellows (red) from below over the bead and secure it with a conventional cable tie (marked blue in the picture).
- Observe chapters 9.2.3 and 9.2.4 Dimension sheets for extraction with regard to the use of different drills.
- Note the possible spring deflection of 13mm + protrusion of the drill 5mm results in a maximum drilling depth of 18mm with suction.
- In order to extend the suction by 20mm, it is possible to attach an additional suction nozzle.
- When retrofitting the long version, first mount the 2-part extension using a cable tie (marked blue in the picture).
- Then slide the bellows (red) over the bead from below and secure it with a conventional cable tie (marked blue in the picture).

5.4 Mount the suction system



Information

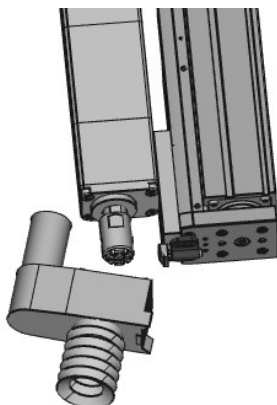

Illustration 5 mount suction system

Please note the following points during assembly:

- Before assembly, clean the parts with a paintbrush, brush or a clean, lint-free cloth.
- Do not use compressed air.
- Prepare the base module with the drilling tool.
- Then carefully slide the extractor over the prepared base module.
- Make sure that the locking bolt (orange in the picture) clicks into place.
- Attach your suction hose with an inner diameter of Ø 25mm to the socket (1).
- Make sure that you clamp the suction hose to the base module with a clamp, if necessary, in order to ensure strain relief.
- The suction hose can also be faced with a cable tie.

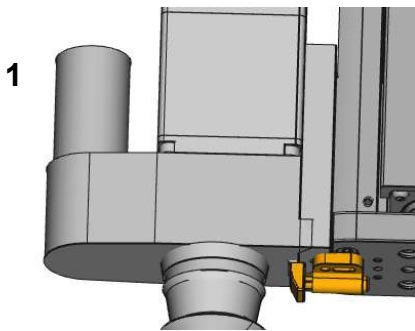

Illustration 6 locking bolt

- Among other things, make sure that the suction hose is laid in such a way that the suction can be removed to change tools without having to remove the suction hose beforehand.
- To change tools, pull the locking bolt backwards with your thumb and remove the suction downwards.



Danger!

An unlocked suction chamber can cause serious injuries or even death and severely damage the machine.

- Before installation, make sure that the locking bolt is firmly seated and functional.
- Check whether the locking bolt is securely locked after assembly.

5.5 Replacing the Base Module

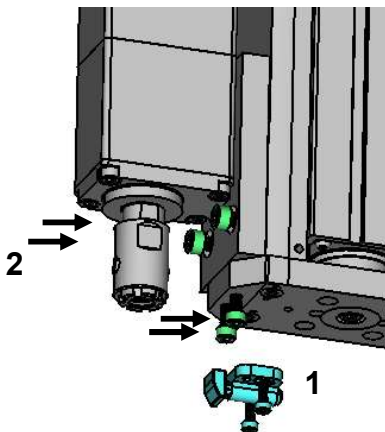

This section applies to the operation of the base module on the LFUXXF.

- Make a note of the position in which the locking bolt (1) is mounted. If necessary, mark the position beforehand with a pen or carve a notch.
- Loosen the 2pc M3 screws and remove the locking bolt (1).
- Loosen the 4pc screws (2) (2pcs M4 and 2pcs M5) and remove the plate together with the base module.
- Disassemble the module from the plate (3) and replace the module.

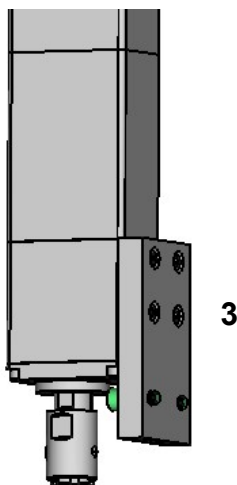

- After replacing the module, reassemble the unit in reverse order.
- Wet the threaded holes for the screws with screw locking adhesive (e.g. Loctite® 243).
- Tighten the screws according to the table.

Tightening torque fastening screws

M3	1,0Nm ±10%
M4	2,4Nm ±10%
M5	4,8Nm ±10%

Tbl-1.1: Tightening torques for fastening screws

5.6 Install electrical connectors (A)



Danger!

Electrical parts lead to electric shocks when touched, causing serious injuries and even death.

- Before electrical installation work, observe the five safety rules for electrical engineering:
 1. Unlock
 2. Secure against restart
 3. Check that there is no voltage
 4. Ground and short-circuit
 5. Cover close electrical parts
- Check whether the protective caps are on the plugs. If the protective caps are missing, check the connectors for damage and dirt.



Danger!

Electrical work in wet conditions can lead to electric shock, which can lead to serious injuries and even death.

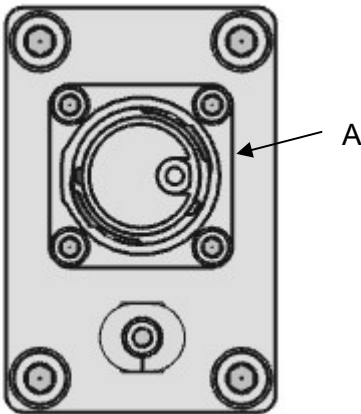

- Only carry out the electrical installation in dry rooms.
- Connect the motor connector (A) of the Basic Module (M17, 9-pin) to the motor connection cable of the sensorless servo controller (control box).
- You can find the cable assignment in chapter 9.1.3 "Pin assignment motor connector M17, 9-pin (on the Basic Module side)".
- Provide a plug on the motor connection cable that matches the motor connection plug in accordance with chapter 9.1.3 "Pin assignment of the motor connection plug M17-9-pin (Basic Module side)". The cable assignment can be found in chapter 9.1.2 "Pin assignment motor connector M17, 9-pin (on the Basic Module side)".

Illustration 7 connector

5.7 Connect pneumatics (sealing air) (A)

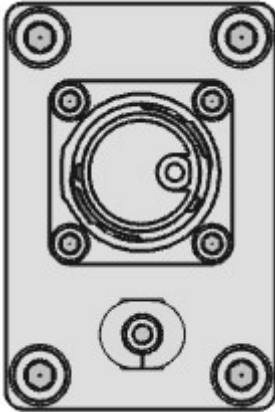
**Danger!****Risk of injury from tearing off compressed air hoses.**

- Wear safety glasses when working on the pneumatic system.
- Make sure that the compressed air hose is long enough.
- Connect the sealing air to the connector (A).
- For sealing air specification, see chapter 9.1.1 "Sealing air."

Illustration 8 Pneumatic

6. Commissioning and operation

Before starting work, inform yourself about the general safety instructions (see chapter 2.7 "General safety instructions").

**Danger!****Tools that are thrown out due to high speeds or insufficient fastening can cause serious injuries and even death.**

- Always operate the Basic Module with a clamped tool.
- Do not enter the machine in which the Basic Module is installed until the machine is completely switched off.
- Observe the specified maximum speeds of the Basic Module, see chapter 9.1 "Technical data" and the maximum speed of the clamped tool.
- Suitable protective devices must be available and fully functional. The provision is the responsibility of the manufacturer of an complete system.

**Danger!****Hearing damage due to noise pollution.**

- Wear suitable protective equipment during commissioning and operation.



Stop!

Damage caused by imbalance and dirt particles.

- Always operate the Basic Module with sealing air and only use sealing air that is free of dirt, water and oil, see chapter 9.1.1 "Sealing air".



Stop!

Improper operation can damage the Basic Module.

- Only use the Basic Module up to its maximum limit values, see chapter 9.1 "Technical data", tables "Tbl-6", "Tbl-7" and "Tbl-8".
- For other operating conditions, please contact **ToolDrives GmbH & Co. KG**.
- Use the Basic Module only in a clean and dry environment.
- Do not use the Basic Module outdoors.
- Only operate the Basic Module when it is permanently installed.
- Check whether all plugs are firmly attached.



Information

The sealing air hole can be closed for basic modules with a gear.

- An M3x8 countersunk screw is foreseen to close the sealing air outlet opening.
- This screw is not installed and is only to be used in the event that the sealing air is not present, so that no dirt is transported into the spindle from the outside.



Attention

The screw must be removed when operating with sealing air.

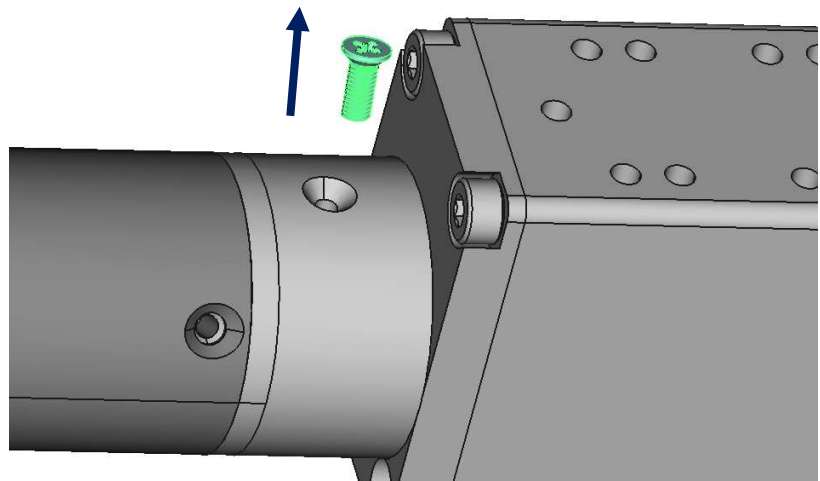

6.1 EMC-measurements

Only when operating with the sensorless servo controller type ToolDrives (Control Box) do we assure you that the limit values and the requirements regarding interference emission and immunity to interference according to EN 61800-3: 2004 are met.

When operating the Basic Module with another servo drive, EMC measurements must be carried out and evaluated.

6.2 Set up and change tools



Danger

Objects thrown around by rotating components can cause serious injuries and even death.

- Remove objects and assembly tools from the Basic Module before putting it into operation.



Danger!

Unsuitable tools can lead to excessive heat development during material processing (risk of fire).

- Use drills or tools only in clockwise rotation.
- Only set up suitable tools to keep drive torques low. Replace worn and encrusted tools immediately.



Information

The Basic Module is designed for the following tools:

- Drills with a maximum tool shank of $\varnothing 7$ to 10mm correspond to the selected holders (ER11 up to 7mm and H.S.Weldon up to 10mm) with a length corresponding to the selected suction device.
- If you use hardware drills, you are welcome to coordinate the drilling strategy with us. Please then contact **ToolDrives GmbH & Co. KG**. We can support you with information on the speed in connection with the feed.
- When setting up the tools, note the different tool holders:
 - 6.2.1 "ER11 (collet) tool holder (DIN ISO 15488)".
 - 6.2.2 "High Speed Weldon tool holder".
 - 6.2.3 "Square drive tool holder".
- If you have any questions, please contact **ToolDrives GmbH & Co. KG**.

6.2.1 ER11 (collet) tool holder (DIN ISO 15488)

Mount the collet

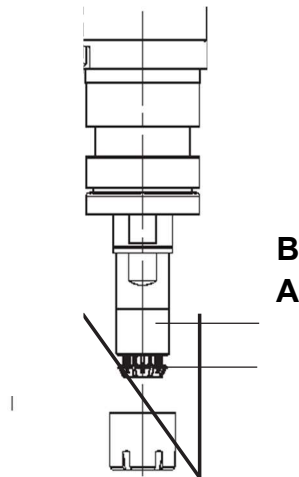

Illustration 9 Collet -1

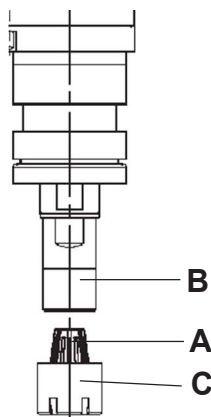

Illustration 10 Collet -2

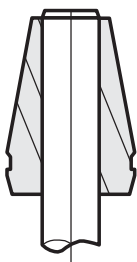

Illustration 11 Collet -3

- Do not insert the collet (A) directly into the tool holder (B).
- Clean the collet (A), clamping nut (C) and the tool holder (B) with a brush or a lint-free cloth.

- Do not use compressed air.
- Place the collet (A) in the clamping nut (C).
- Turn the collet until the eccentric ring of the clamping nut snaps into the groove of the collet.
- Only mount the collets in the tool holder when they are locked.
- Screw the clamping nut (C) together with the snap-in collet (A) into the tool holder (B).
- Clean the tool holder with a brush or a lint-free cloth before inserting the tool (A).
- Do not clean with compressed air.

- Insert the tool (A) with the complete shank length into the collet (C).

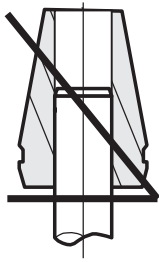

Illustration 12 Collet -4

- Check that the tool is firmly fitting.

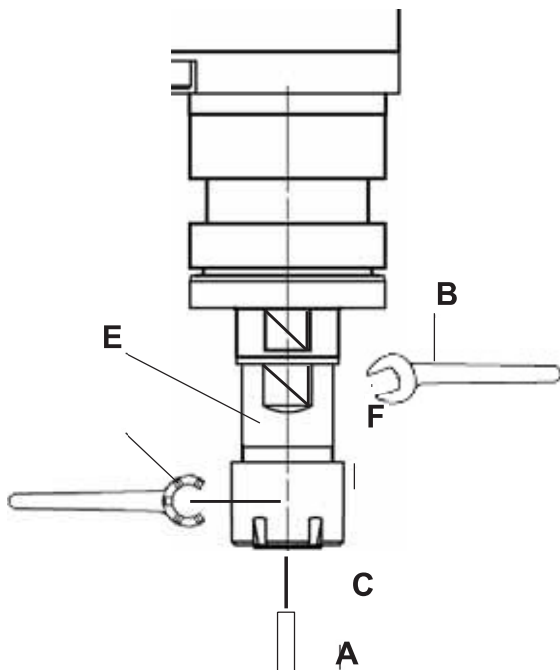

Illustration 13 Collet -5

- Hold the tool holder (E) with an SW 11 spanner (B).
- Tighten the clamping nut (F) with the key (D) for ER11 clamping nuts, for tightening torques see table "Tbl-2".
- Follow the instructions of the manufacturer of the collet.

Clamping diameter	Tightening torque
1,0 - 2,5 mm	10 Nm \pm 10 %
3,0 - 7,0 mm	16 Nm \pm 10 %

Tbl-2: Tightening torque ER11 Collet

Insert and clamp the tool



Danger!

Tools that are not properly tightened can be thrown out and cause serious injuries and even death.

- Only operate the motor with a clamped tool.
- Assembly according the specified tightening torques.
- Note the clamping range of the collet.
- Check that the tool is firmly positioned in the spindle.



Information

Damage to the collet due to unsuitable tools.

- Only use tools **without** a clamping surface.
- Check whether the direction of rotation of the motor matches the clamped tool.

6.2.2 High Speed Weldon tool holder

Insert and clamp tools

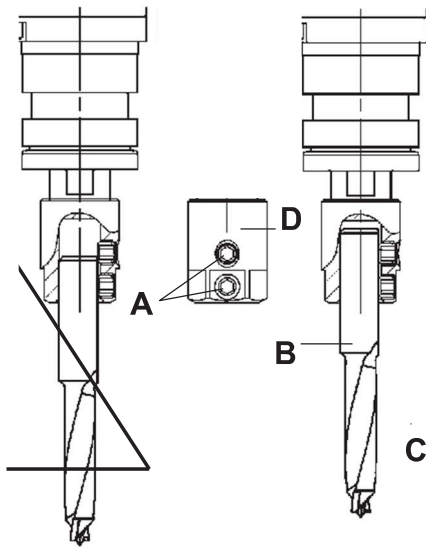

Illustration 14 Insert tool-1

- Loosen the clamping screws (A) with an SW 3 Allen key.
- Clean the tool holder (D) with a brush or a clean, lint-free cloth.
- Do not use compressed air.
- Push the tool (B) into the tool holder as far as it will go.
- Only use tools with a shank $\varnothing 10_{g7}$.
- Insert the tool so that the clamping surface (C) faces the clamping screws (A).
- Make sure that the clamping screws press on the surface at a right angle, otherwise the tool can come loose during operation.

Correct, because right-angled



Wrong because not right-angled

Illustration 15 Insert tool--2

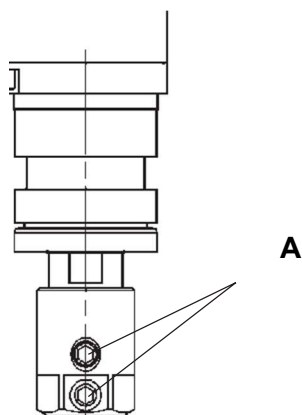

Illustration 16 Insert tool--3

- Tighten the clamping screws (A) with **4.5 Nm \pm 10**.

Insert and clamp the tool



Danger!

Tools that are not properly tightened can be thrown out and cause serious injuries and even death.

- Only operate the motor with a clamped tool.
- Assembly according the specified tightening torques.
- Note the clamping range of the collet.
- Check that the tool is firmly positioned in the spindle.



Information

Damage to the collet due to unsuitable tools.

- Only use tools **with a clamping surface**.
- Check whether the direction of rotation of the motor matches the clamped tool.

6.2.3 Square drive tool holder

There are no specific instructions for use in this manual for square drives. The recordings can be used in accordance with usual practice. Please note that the safe attachment of the tools and the control are your own responsibility.



Danger!

Improperly attached tools can be ejected and cause serious injury or death.

6.3 Direction of rotation of the motor spindles



Danger!

Incorrect direction of rotation of the motor spindles can throw parts out and cause serious injuries and even death.

- Only operate the motor spindles in the correct phase (counter-clockwise rotating field).
- Check that the motor spindles have the specified direction of rotation.

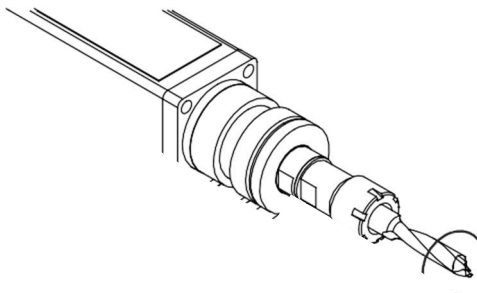

Illustration 17 Direction of rotation

7. Maintenance and disposal

Find out about the general safety instructions before starting work (see chapter 2.7 "General safety instructions").



Parts damage due to incorrectly performed maintenance work.

- Repair and maintenance work may only be carried out by qualified specialists.
- During repair and maintenance work, pull the supply plug on the Basic Module to de-energize it.
- Do not use a steam jet, compressed air or similar to clean the Basic Module.
- Never bring cleanser inside the Basic Module.
- Clean tool holders including ER 11 collets and mini clamping nuts with a brush or a lint-free cloth.
- Do not open the Basic Module.



Cut injuries on tool cutting edges.

- Disassemble the tools before maintenance.
- Note other tools on the machine.
- Wear protective gloves when dismantling the tools.

7.1 Maintenance work

The Basic Module maintenance free Regular visual inspection and maintenance is still necessary to identify any damage that may occur.

7.1.1 Ball bearings

The spindle bearings are equipped with lifetime grease lubrication. They are maintenance-free, but they do not mean that they will last forever. See maintenance schedule chap. 7.5.



Do not lubricate the ball bearings. Do not put greases, oils or cleaning agents in the openings of the Basic Module.

7.1.2 Visual inspection



Danger!

Risk of injury from tearing off compressed air hoses.

- Maintain and check compressed air hoses and screw connections regularly.
- Wear safety glasses when working on the pneumatic system.
- Check the Basic Module, all supply lines and connectors for external damage.
- Check whether the identification plate and the safety plate (see chapter 3.1 "Identification plate" and chapter 2.8 "Safety plate") are present and legible.

7.1.3 Cleaning

Only clean the outside of the Basic Module with a brush or with a clean, lint-free cloth. Remove any chips from the Basic Module.

7.2 Check the tightening torques of the fastening screws

Check the tightening torques of the Basic Module fastening screws on the module and on the tool holder.



Danger!

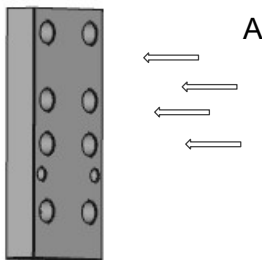

Parts can be thrown out by loosening the Basic Module fastening screws and cause serious injuries.

- The tightening torque of the fastening screws is **2,4 Nm ± 10%** (see also chapter 5.3).
- If you check the tightening torques that a Basic Module fastening screw (A) can be turned further, follow the instructions under "Reinstall screw".

Illustration 18 Fastening screws



Information

Remount the screw.

- Make sure that the Basic Module can be reassembled on the mounting frame without damaging the machine.
- Observe the safety and processing instructions for the screw locking adhesive used. Loosen the screw.
- Remove the adhesive residue from the threaded hole and from the screw.

- Degrease the screw.
- Coat the threaded hole for the screw with screw locking adhesive (e.g. Loctite® 243).
- Screw in the screw and tighten it with the specified tightening torque.
- If you do not reach the specified tightening torque when tightening the screw, contact **ToolDrives GmbH & Co. KG**.

7.3 Check the tightening torque of the tool



Danger!

An incorrectly tightened tool holder can be thrown out and cause serious injuries and even death.

Too strong tightening torques lead to damage to the thread.

- Check the tightening torque regularly.
- **Torques:** See table "Tbl-3".
- If you have any questions or uncertainties, please contact **ToolDrives GmbH & Co. KG**.

Tool holder	Tightening torque	Chapter
ER11 (collet)	10 Nm ±10 %	7.3.1 "ER11 (collet) torque check"
High Speed Weldon	10 Nm ±10 %	7.3.2 "High Speed Weldon torque check"

Tbl-3: Tightening torque

7.3.4 ER11 (collet) tightening torque check

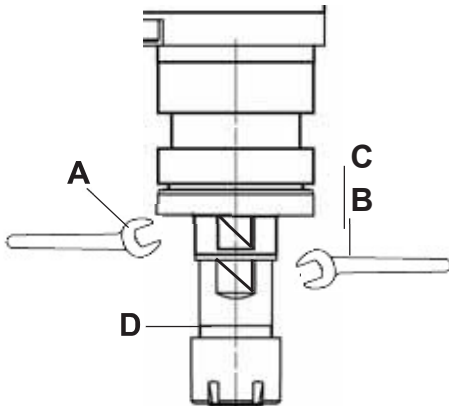

Illustration 19 Tighten tool holder -1

- Hold the motor spindle (C) with an SW 13 spanner (A).
- Tighten the tool holder (D) with a wrench SW 11 (B) with the specified tightening torque, see table "Tbl-3".
- If you **do not** reach the specified tightening torque when tightening the tool holder, contact **ToolDrives GmbH & Co. KG**.

7.3.5 High Speed Weldon tightening torque check

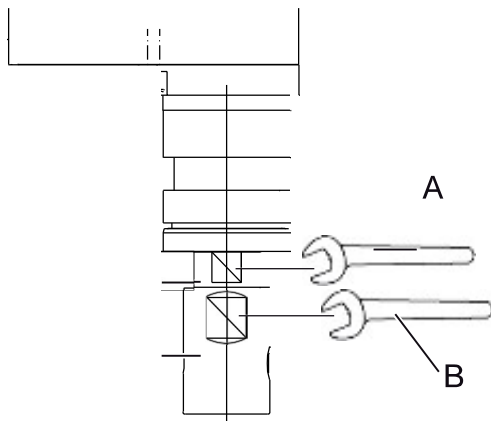

Illustration 20 Tighten tool holder -2

- Hold the motor spindle (C) with an SW 13 spanner (A).
- Tighten the tool holder (D) with an SW 17 spanner (B) with the specified tightening torque, see table "Tbl-3".
- If you **do not** reach the specified tightening torque when tightening the tool holder, contact **ToolDrives GmbH & Co. KG**.
- Halten Sie die Motorspindel (C) mit einem

7.4 Commissioning after maintenance



Information

Commissioning after maintenance.

- Objects thrown by rotating components can cause serious injuries and even death.
- Remove objects and tools from the basic module before starting it up.
- Only clean the outside of the Basic Module.
- Mount the tools, see chapter 6.2 "Set up and change tools".
- Install all safety devices.
- Connect the motor connection cable and the compressed air hoses.

7.5 Maintenance schedule

Maintenance work	When starting up	Weekly	Every 500 operating hours or every 3 months	Every 5000 operating hours
Visual inspection (see chapter 7.1.2)	X		X	
Check the tightening torques (see chap. 7.2 - 7.3)	X	X		
Cleaning (see chapter 7.1.3)	X	X*		
Ball bearing lubrication (To be carried out only by the manufacturer)				X
* or more, depending on the location and the operating conditions				

Tbl-4: Maintenance schedule

7.6 Disposal

Additional information on disassembly and disposal of the Basic Module is available from our customer service.

- ▶ Please dispose of cardboard boxes in the waste paper, other packaging materials in the designated disposal points.
- ▶ Dispose of the Basic Module at the designated disposal points (electronic components included).
- ▶ Observe the applicable national regulations for disposal.

7.7 Spareparts AC-Codes

Description	Usage	AC-Code (order code)
Mini nut ER11	Basic Module without extension ER11	40021486
Bellows	Basic Module with internal suction	30000064

Tbl-5: Spare parts

8. Interruptions

8.1 In general



A changed operating behavior can be an indication of existing damage to the Basic Module or cause damage to the Basic Module.

- Do not put the Basic Module back into operation until the cause of the error has been eliminated.
- Faults may only be repaired by trained specialists.

8.2 Errors - possible causes - remedies

Errors	Possible causes	Remedies
Increased operating temperature	Ambient temperature too high, cooling too low	Provide adequate cooling and remove chip accumulation.
	Overload (motor or gear)	Reduce the feed, extend the machining cycle.
	Tool worn, damaged, encrusted	Exchange the tool.
	Sealing air is missing or the flow rate is too low	Provide the sealing air supply according to the instructions.
Increased operating noise	Tool defective	Exchange the tool.
	Tool holder loose	Check the tool holder (note the tightening torques).
	Bearing damage	Get in touch with our Customer service
	Basic Module fastening screws loosened	Check the screw connections and, if necessary, pull them according to Instructions according to.
	Gear damage	Go in contact with customer service
Collision		Get in touch with our Customer service.
Motor does not turn	no electrical connection	Check the plug position and the motor cable.
	increased operating temperature due to lack of sealing air	Provide the sealing air supply according to the instructions.
	Dirt entry in the sealing system	Get in touch with our Customer service.
	Gear damage	Go in contact with customer service
Motor stops during processing	Overload	Reduce the burden. Check the machining parameters.
The required tightening torque is not reached	Thread damaged	Get in touch with our Customer service.

Tbl-6: Interruptions

9. Appendix

9.1 Technical data

Type code see chapter 3.3		BV032-01-	BV032-01-	BV032-01-
Tool Holder		ER11 (collet)	High Speed Weldon	Square drive
Max. rotational speed n_{max}^*	rpm	16.000	12.000	-
With 1-stage gear 4:1	rpm	-	-	1250
With 2-stage gear 12.08:1		-	-	420
Max. Acceleration (during operation)	m/s ²	19,6 (2 g)		
Max. Axial force (on the motor spindle)	N	300		
Length	mm	47,8		
Hight	mm	31,8		
Weight (see chapter 9)	mm	250 up to 306		
Masse (incl. encoder)	kg	0,99 (1,05)	1,00 (1,06)	-
With 1-stage gear 4:1 (incl. encoder)	kg			1,12 (1,18)
With 2-stage gear 12.08:1 (incl. encoder)	kg			1,16 (1,22)
Housing temperature	°C	< 80 (max. allowed)		
Degree of protection		IP 54		
Operating and environmental conditions				
Ambient temperature	°C	+15 bis +40		
Relative humidity (not condensing)		≤ 85 %		
Use over NN	m	≤ 1000		
* The permissible maximum speed depends on the tool holder and the tool. The performance data are determined on the Single Servo Controller type ToolDrives.				

Tbl-7: technical data

9.1.1 Sealing air >(specification)

For connectors for sealing air hose outside diameter 4mm

Description	Unit	BV032-01-000
Operating pressure on the input side of the connector	bar	0,3 – 1,5
Sealing air quality DIN ISO 8573-1		free of dirt, oil and water
Filter class 1 DIN ISO 8573-1	µm	0,01
Sealing air volume flow Q_N	l/min	12,5

Tbl-8: Sealing air specification

9.1.2 Motor data

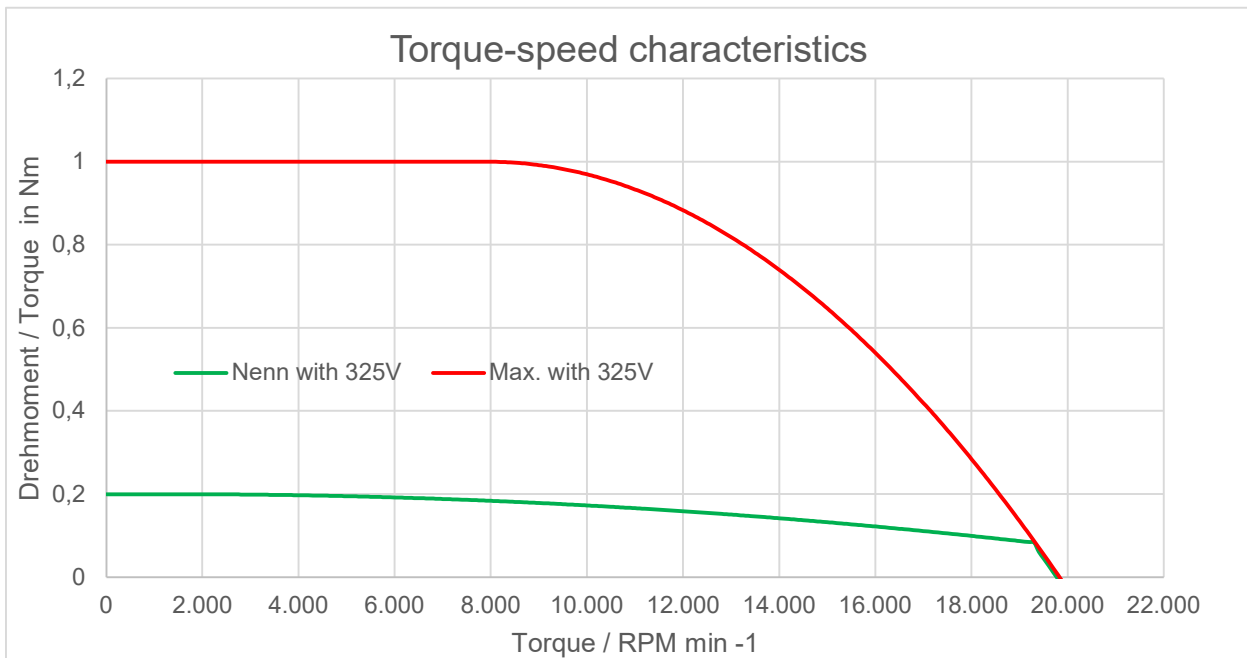

Description	Unit	Basis without gear	Gear 1-stage	Gear 2-stages
Motor type		1x Three-phase synchronous motor per Basic Module		
Direction of motor rotation (against clockwise with a view of the tooholder)		Counterclockwise rotation		
Terminal voltage U_{KI} (Peak value)	V	325		
Max. Power P_{max} (short-term)	W	800		
Max. Current I_{max} (short-term)	A _{eff}	11,2		
Max. Torque M_{max} (short-term)	Ncm	100	300	600
Nominal torque M_{nenn}	Ncm	9	see diagramm	see diagramm
Nominal speed n_{nenn} (at the drive)	min ⁻¹	18000	(5000)	(5000)
Nennfrequenz f_{nenn} *	Hz	600	166	166
Nominal current I_{nenn}	A _{eff}	1,7	see diagramm	see diagramm
Idle speed n₀	min ⁻¹	20000	5000	5000
Operating speed n at the output	min-1	400 bis 18000	100 bis 1250	35 bis 420
Operating speed n with Encoder*	min-1	0 bis 18000	0 bis 1250	0 bis 420
Connection resistance R_{tt} (Phase - Phase)	Ω	11,5		
Connection inductance L_{tt} (Phase - Phase)	mH	5,9		
Voltage constant	V/1000 min ⁻¹	12,5		
Torque constant K_t	Nm/A	0,11		
Number of pole pairs p		2		

Tbl-9: Motor data

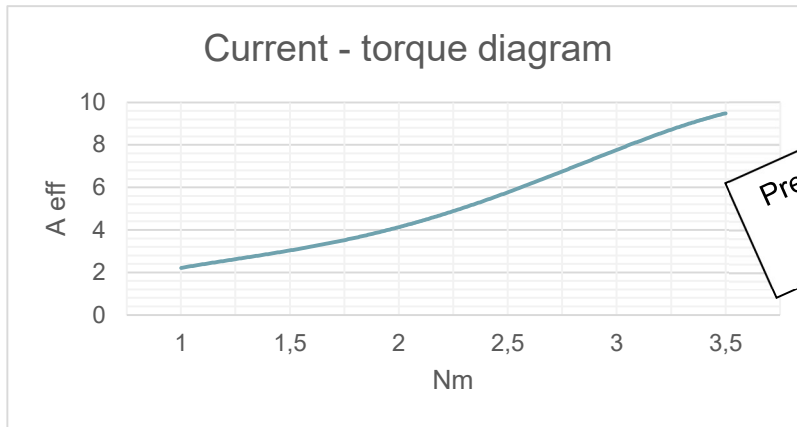

Preliminary diagram for 1-stage gearbox

9.1.3 Pin assignment motor connector

- ▶ Manufacturer: Intercontec
- ▶ Order No: Connector M 17 9-pin (3 +PE; 5 Signal) EEG A 201 NN 00 0500 000
- ▶ 4x contact pin 61.231.11 & 2x contact pin 61.232.11
- ▶ Pin assignment also applies when using an angled connector

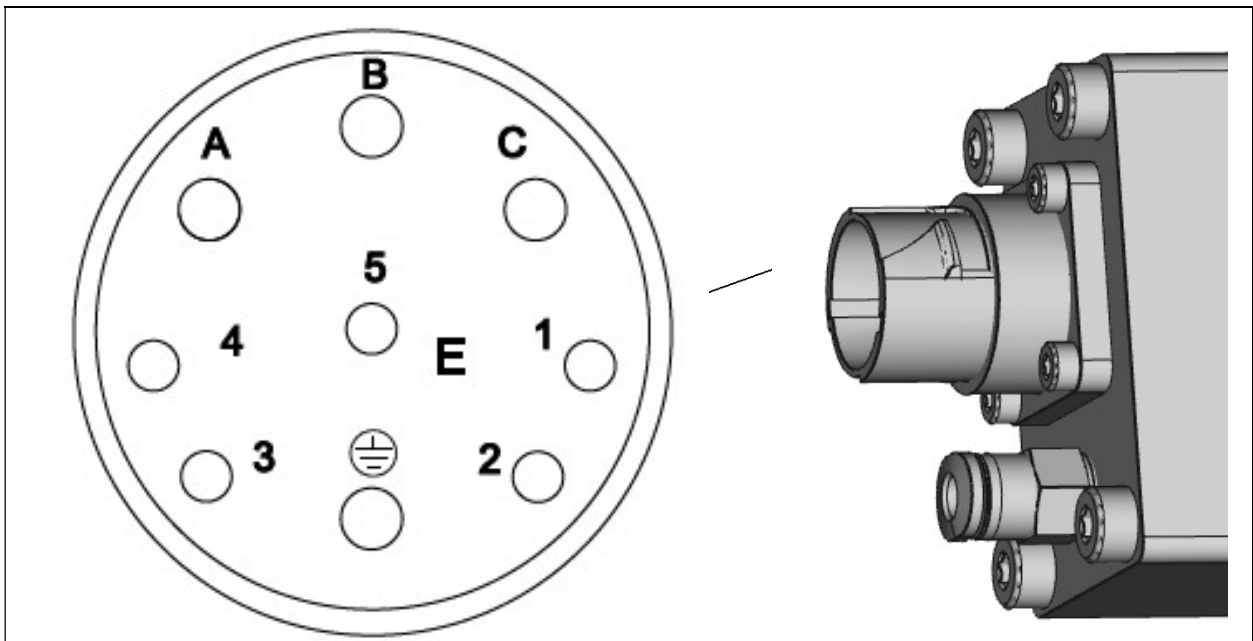

Pin	Assignment
A	Motor 1/Phase W red
B	Motor 1/Phase U green
C	Motor 1/Phase V black
⊕	PE
1	Temperature sensor (PTC-1000) red
2	Temperature sensor (PTC-1000) black
3	Not assigned
4	Not assigned

Tbl-10: Pin assignment motor connector M17 – 9-pin (on Basic Module side)

9.1.4 Motor protection characteristic (KTY) Silicon temperature sensor KTY84-130

Characteristics	
Sensor resistance R_{100}	970 Ω - 1030 Ω
Temperature range T_{amb}	-40 $^{\circ}\text{C}$ / +300 $^{\circ}\text{C}$
Power $I_{cont} = \text{max.}$	10mA

Tbl-10: Characteristics

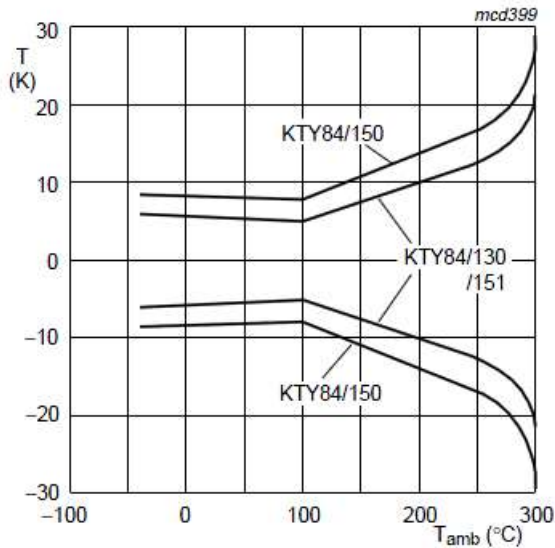

Maximum temperature error (ΔT)

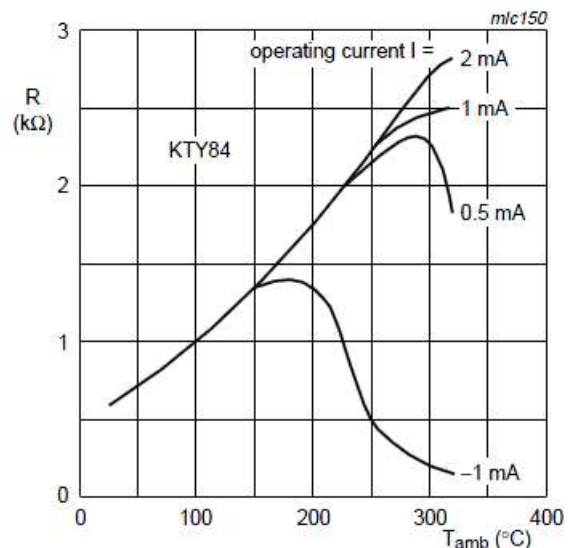

Sensor resistance depending on the ambient temperature (average values)

Ambient temperature ($^{\circ}\text{C}$)	Temp. Coefficient (% / K)	Resistor (Ω)			Temp. error (K)
		Min.	Type	Max.	
-40	0,84	340	359	379	$\pm 6,48$
-30	0,83	370	391	411	$\pm 6,36$
-20	0,82	403	424	446	$\pm 6,26$
-10	0,80	437	460	483	$\pm 6,16$
0	0,79	174	498	522	$\pm 6,07$
10	0,77	514	538	563	$\pm 5,98$
20	0,75	555	581	607	$\pm 5,89$
30	0,73	599	626	652	$\pm 5,79$
40	0,71	645	672	700	$\pm 5,69$
50	0,70	694	722	750	$\pm 5,59$
60	0,68	744	773	801	$\pm 5,47$
70	0,66	797	826	855	$\pm 5,34$
80	0,64	852	882	912	$\pm 5,21$
90	0,63	910	940	970	$\pm 5,06$
100	0,61	970	1000	1030	$\pm 4,90$
110	0,60	1029	1062	1096	$\pm 5,31$
120	0,58	1089	1127	1164	$\pm 5,73$
130	0,57	1152	1194	1235	$\pm 6,17$
140	0,55	1216	1262	1309	$\pm 6,63$
150	0,54	1282	1334	1385	$\pm 7,10$
160	0,53	1350	1407	1463	$\pm 7,59$
170	0,52	1420	1482	1544	$\pm 8,10$
180	0,51	1492	1560	1628	$\pm 8,62$

Tbl. 11: Temperature - resistance values

9.1.5 Pin assignment of signal connector M17 – 12-pin (on Basic Module side)

- ▶ Additional connector for Basic Module with encoder.
- ▶ Manufacturer: Intercontec
- ▶ Order No. Connector M 17 12-pin (12 signal) EEG A 001 NN 00 0001 000
- ▶ 8 x contact pin 61.232.11
- ▶ Pin assignment also valid when using Y and / or angled plugs

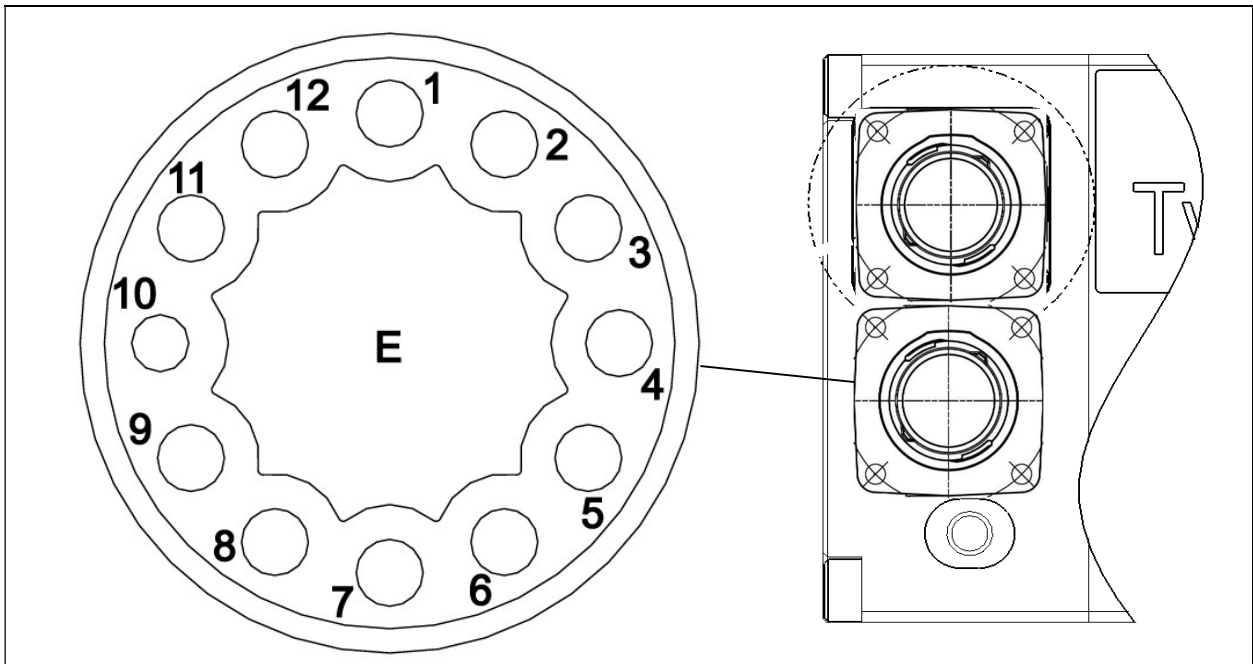

Pin	Assignment
1	V _{dd} red
2	GDN blue
3	A grey
4	B green
5	Z white
6	A- pink
7	B- yellow
8	Z- brown
9	not assigned
10	not assigned
11	not assigned
12	not assigned

Tbl-12: Pin assignment of signal connector M17 – 12-pin (on Basic Module side)

9.1.6 Specification Encoder

- ▶ Manufacturer: Renishaw
- ▶ Model RM44IC encoder
- ▶ Model RM44A3 giver

Characteristics	
Power Supply	$V_{dd} = 5\text{ V} \pm 5\%$
Power consumption	-Max. 35mA
Output signals	A, B, Z, A-, B-, Z- (RS422)
Accuracy	Typ. ± 0.5
Hysteresis	0.18°
Encoder line count	1024
Maximum speed	30,000 rpm
Maximum cable length	50 m
Operating temperature	$-40\text{ }^\circ\text{C}$ to $+125\text{ }^\circ\text{C}$ (IP64) $-40\text{ }^\circ\text{C}$ to $+85\text{ }^\circ\text{C}$ (IP68)

Tbl-13: Specification Encoder

Timing diagram

Complementary signals not shown

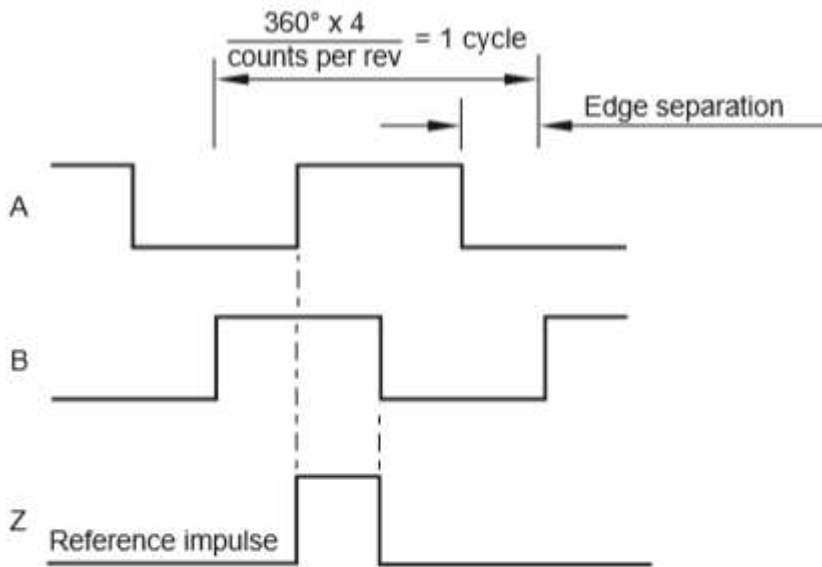

B leads A for clockwise rotation of magnetic actuator.

Recommended signal termination

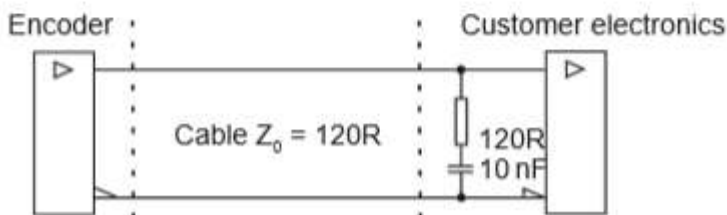

9.2 Dimension sheets

9.2.1 Dimension sheet with one motor spindle

ER11 (collet) or High Speed Weldon tool holder with/without encoder

All dimensions in mm

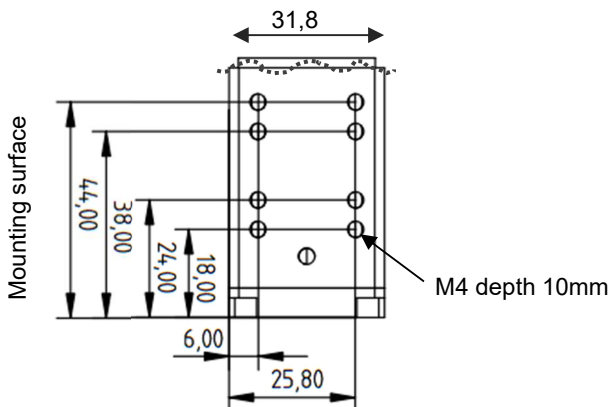
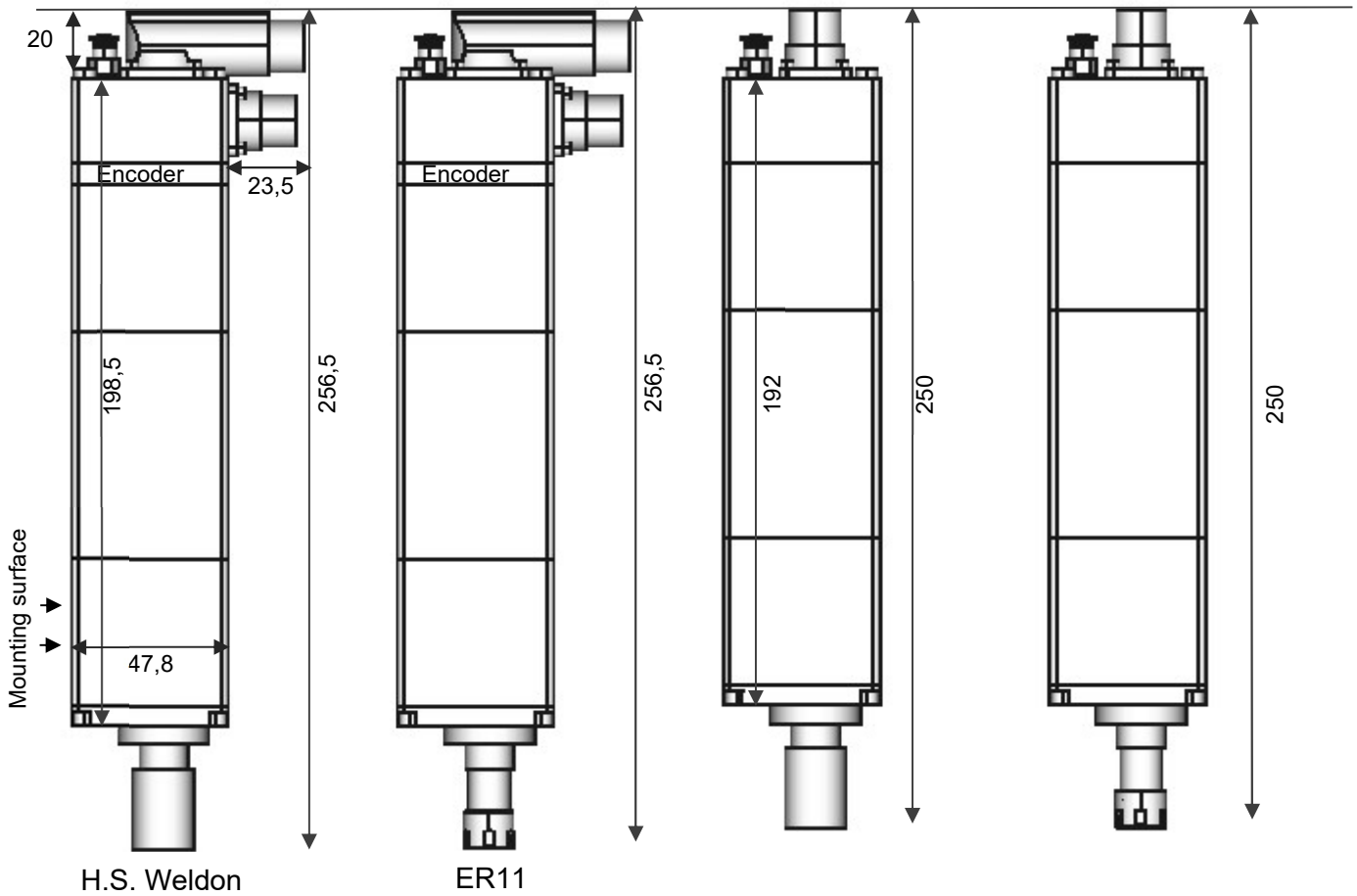

Spindle position

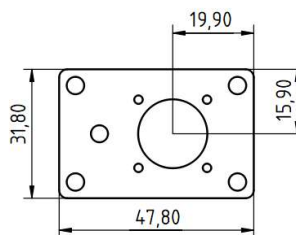

Option: Power connector outlet V

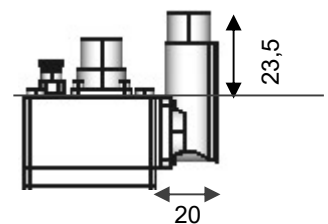

9.2.2 Dimension sheet with gear and square drive

Square drive with gear without/with encoder

All dimensions in mm

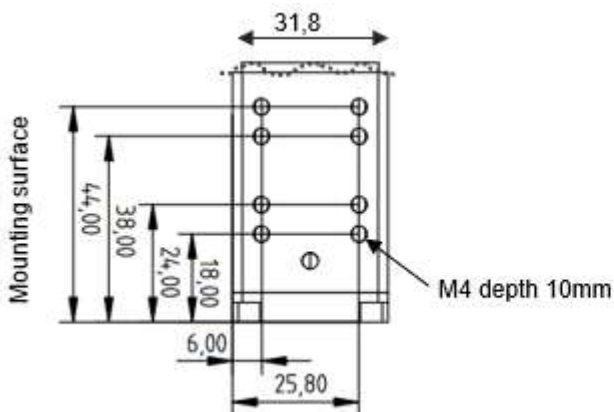
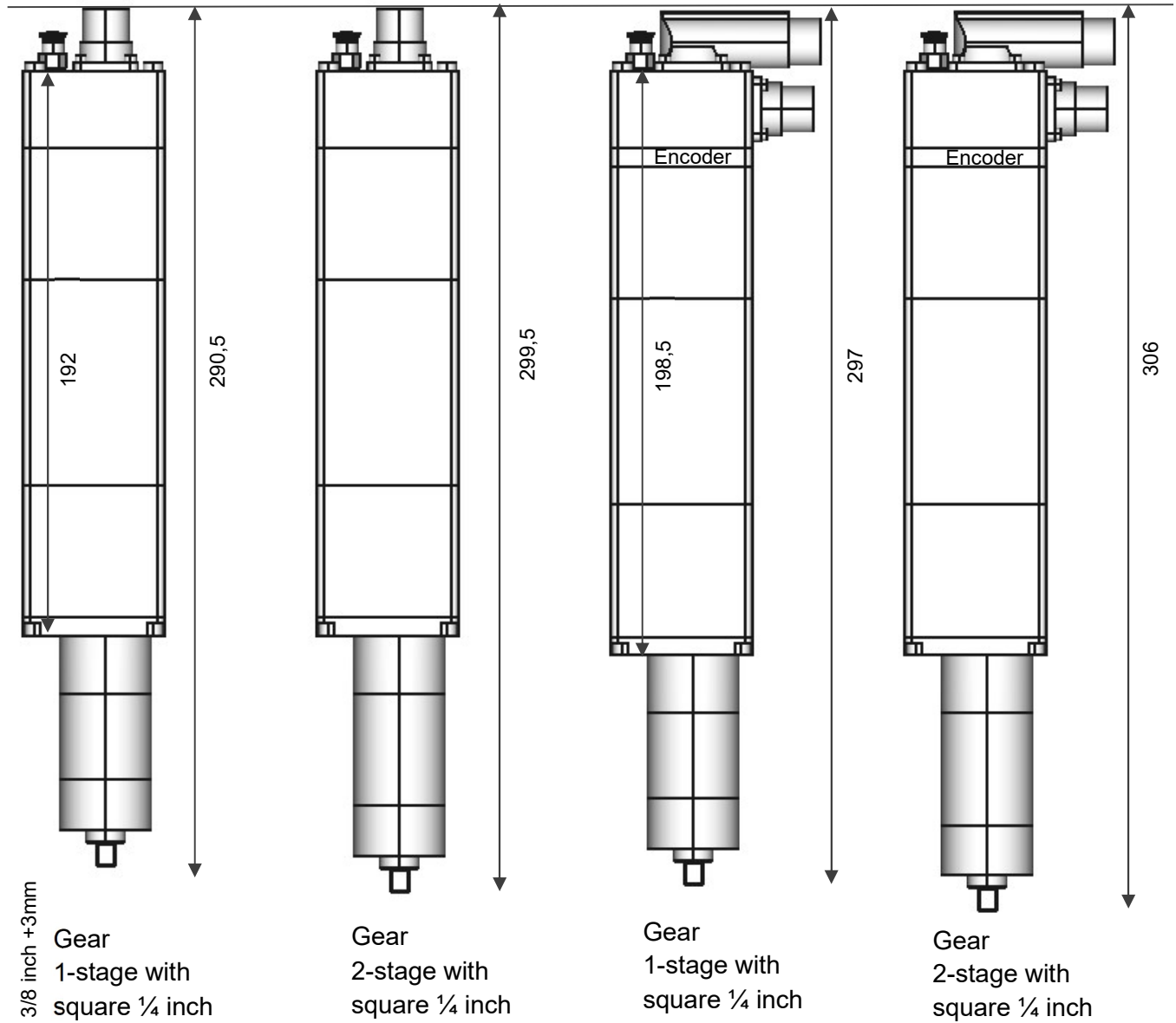

Spindle position

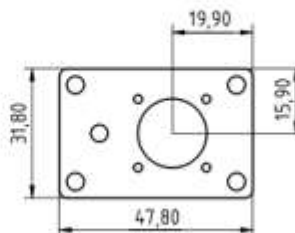

Option: Power connector outlet V

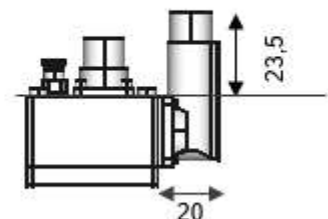

9.2.3 Dimension sheet suction

Dimension sheet Basic module suction for 58mm or with extension for 78mm tools

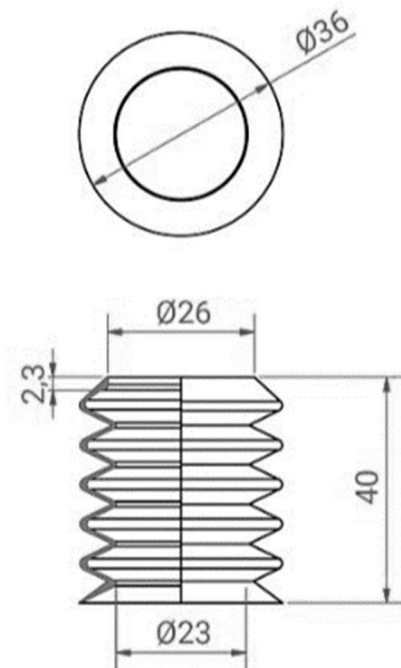
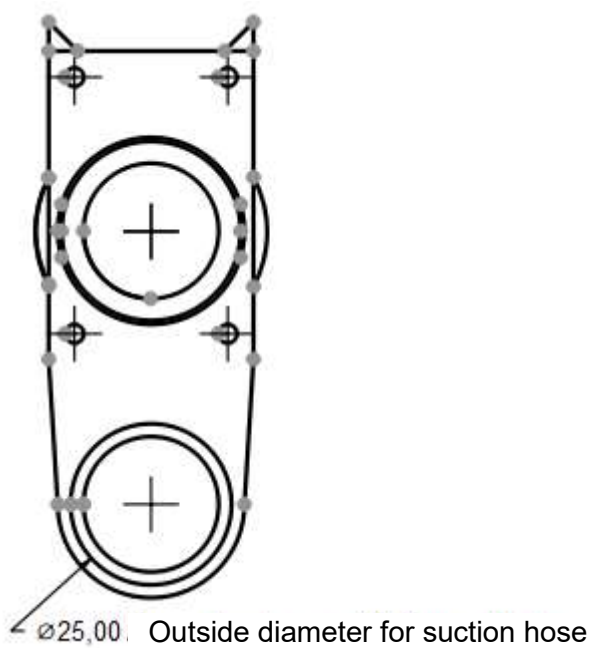
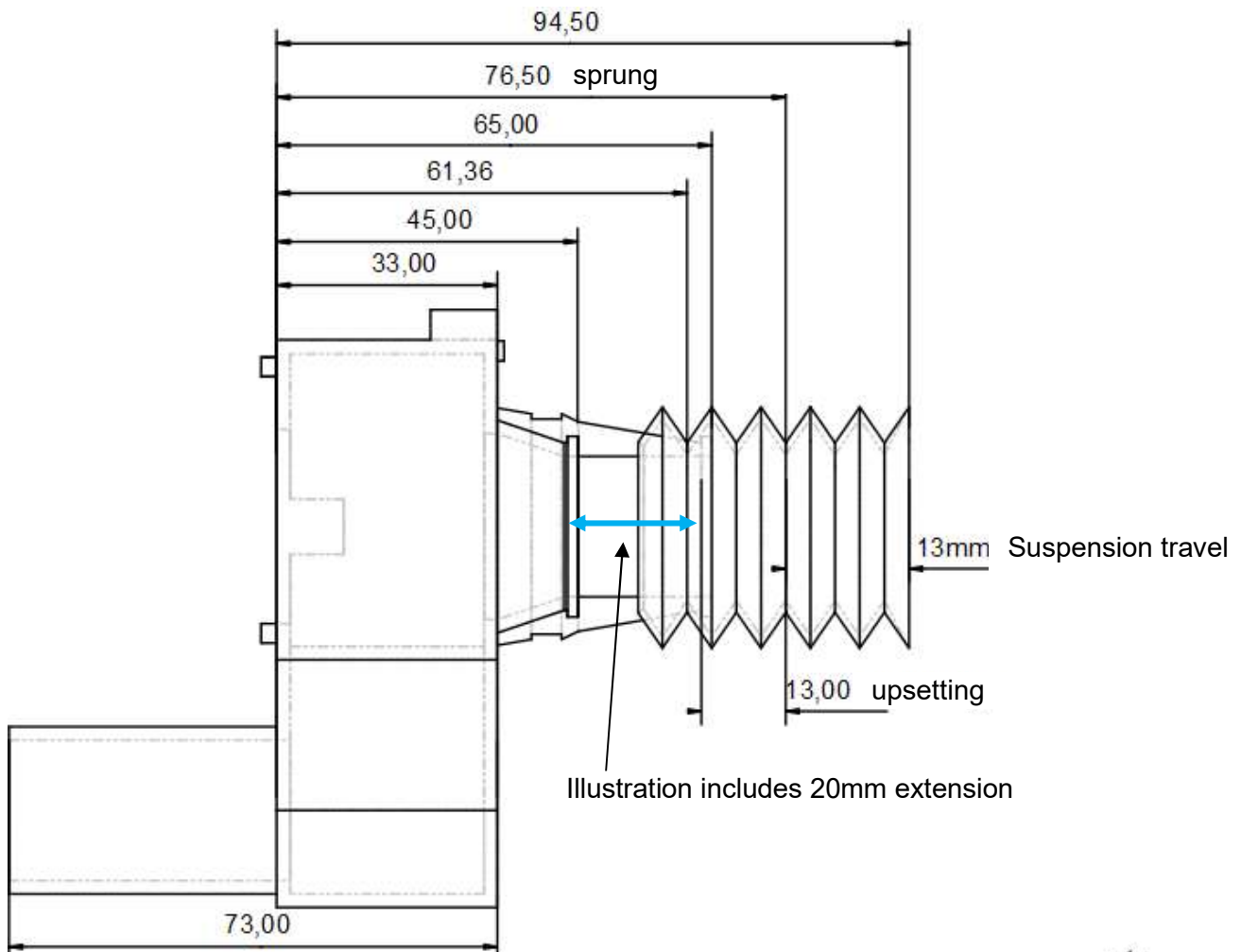

9.2.4 Dimension sheet schematic representation of the drill length

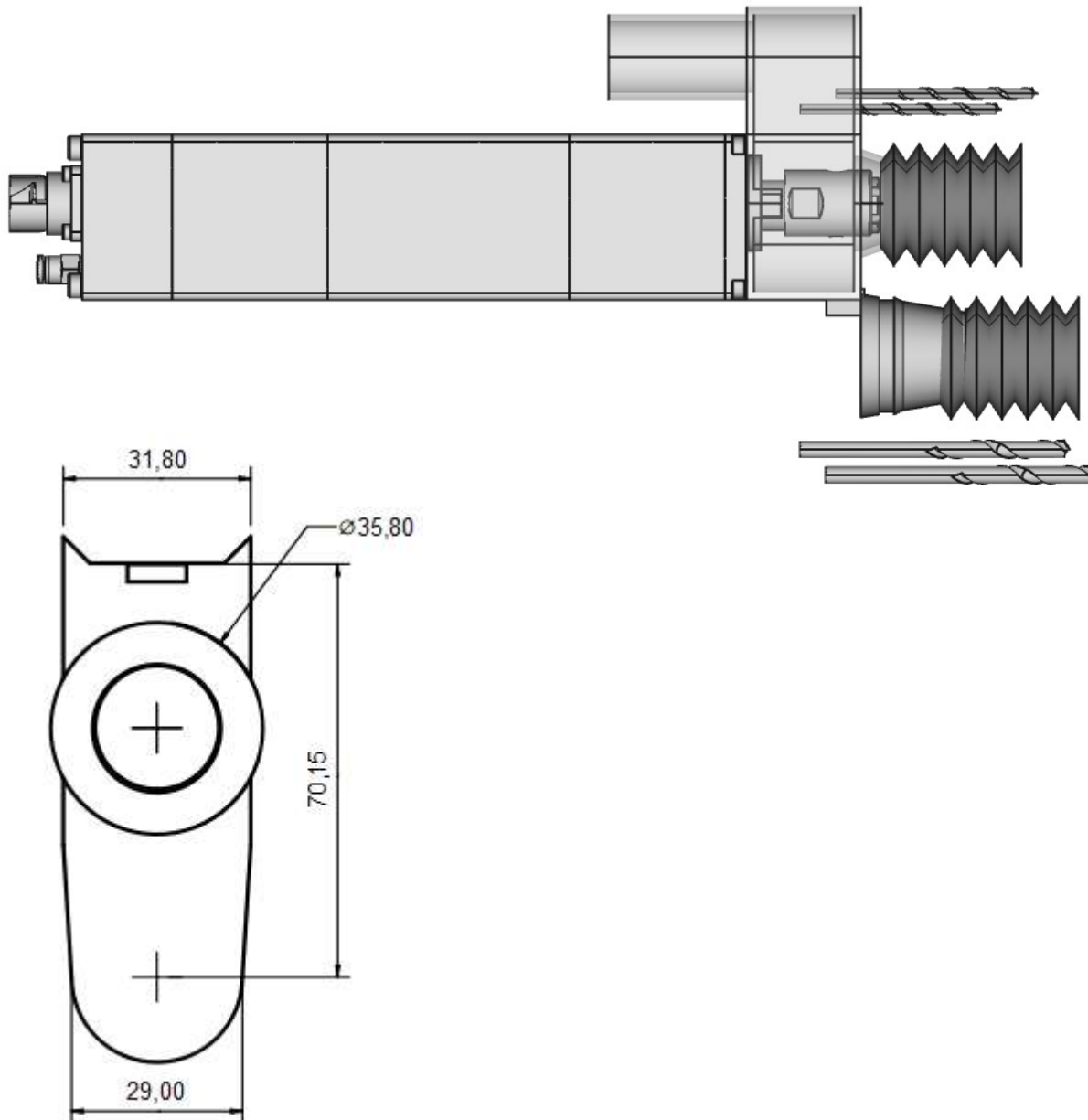

Schematic representation of drilling tools with extraction Example:

Short drill 58mm

Long drill 78mm

Overhang drill of 5mm possible

Spring travel 13mm + protrusion of the drill 5mm results in a maximum drilling depth of 18mm with suction

10. Declaration of Conformity



ToolDrives GmbH & Co. KG
Königlicher Wald 6
33142 Büren
Phone +49 2951 70798 50

DE – EG-Konformitätserklärung

EN – EC Declaration of Conformity

<p>Wir erklären, dass das nebenstehend angegebene Produkt ... We declare that the product specified here ...</p>	<p>Basis Modul / Basic Module BV032-01-000...K</p>
<p>Serial no.</p>	<p>Diverse</p>
<p>... den grundlegenden Anforderungen der folgenden Richtlinien entspricht ... complies with the basic requirements of the following directives</p>	<p>2006/95/ EG Niederspannungsrichtlinie EC Machinery Directive</p>

... und somit die Anforderungen erfüllt. Die Gültigkeit der EG-Konformität erlischt bei Verwendung von Ersatzteilen, die nicht von ToolDrives GmbH & Co.KG zugelassen sind. Compactmodule der oben genannten Baureihe tragen das CE-Zeichen.

... and therefore meets the requirements. The validity of the EC conformity expires if spare parts are used that are not approved by ToolDrives GmbH & Co.KG. Compact modules of the above-mentioned series bear the CE marking.

<p>Folgende harmonisierte Normen wurden angewandt: / Applied harmonizes standards:</p>	
<p>DIN EN 60204-1:2006 Sicherheit von Maschinen – Elektrische Ausrüstung von Maschinen – Teil 1: Allgemeine Anforderungen. Safety of machines - Electrical equipment of machines - Part 1: General requirements.</p>	
<p>DIN EN 60034-1:2010 Drehende elektrische Maschinen – Teil 1: Bemessung Betriebsverhalten. Rotating electrical machines - Part 1: Dimensioning of operating behavior.</p>	
<p>DIN EN 61800-3:2004 Drehzahlveränderbare elektrische Antriebe – Teil 3: EMV Anforderungen einschließlich spezieller Prüfverfahren. Adjustable speed electrical power drive systems - Part 3: EMC requirements including special test methods.</p>	

<p>Bevollmächtigter für die Zusammenstellung der technischen Unterlagen. Name and address of the person authorised to compile the technical file.</p>	<p>Birgit Meier ToolDrives GmbH & Co.KG Königlicher Wald 6 D-33142 Büren, Germany</p>
<p>Datum / Hersteller-Unterschrift Date / Signature</p>	<p>Februar 02,2023</p> <p></p> <p>Volker Meier Geschäftsführer /General Manager</p>
<p>Name: Funktion des Unterzeichners / Job Description</p>	

This documentation is protected by copyright.

All rights, including those of photomechanical reproduction, duplication and distribution by special processes (e.g. data processing, data carriers and data networks), also particularly, is reserved by **ToolDrives GmbH & Co. KG**.

Subject to content and technical changes.

ToolDrives GmbH & Co. KG

Königlicher Wald 6

33142 Büren

Tel.: +49 2951 70798 50

Mail: info@tooldrives.de

