



Assembly and Operating Manual

GSM-P

Rotary gripping module with parallel gripper

Translation of Original Operating
Manual

Hand in hand for tomorrow

Imprint

Copyright:

This manual is protected by copyright. The author is SCHUNK SE & Co. KG.
All rights reserved.

Technical changes:

We reserve the right to make alterations for the purpose of technical improvement.

Document number: 389104

Version: 15.00 | 26/03/2024 | en

Dear Customer,

Thank you for trusting our products and our family-owned company, the leading technology supplier of robots and production machines.

Our team is always available to answer any questions on this product and other solutions. Ask us questions and challenge us. We will find a solution!

Best regards,

Your SCHUNK team

Customer Management

Tel. +49-7133-103-2503

Fax +49-7133-103-2189

cmg@de.schunk.com



Please read the operating manual in full and keep it close to the product.

Table of Contents

1	General	6
1.1	About this manual.....	6
1.1.1	Presentation of Warning Labels	6
1.1.2	Applicable documents	7
1.1.3	Sizes.....	7
1.1.4	Variants	7
1.2	Warranty	7
1.3	Scope of delivery.....	7
1.3.1	Accessory pack rotational speed rotor FAN.....	8
1.4	Accessories	8
1.4.1	Seal kit	8
1.4.2	Spare parts packages	8
2	Basic safety notes	10
2.1	Intended use.....	10
2.2	Not intended use	10
2.3	Constructional changes.....	10
2.4	Spare parts	11
2.5	Gripper fingers	11
2.6	Ambient conditions and operating conditions	11
2.7	Personnel qualification	11
2.8	Personal protective equipment	12
2.9	Notes on safe operation.....	13
2.10	Transport.....	13
2.11	Malfunctions.....	13
2.12	Disposal	14
2.13	Fundamental dangers	14
2.13.1	Protection during handling and assembly	14
2.13.2	Protection during commissioning and operation	15
2.13.3	Protection against dangerous movements	15
2.13.4	Protection against electric shock.....	15
2.14	Notes on particular risks	16
3	Technical data	19
4	Design and description	20
4.1	Design	20
4.2	Description	20

5 Assembly	21
5.1 Installing and connecting	21
5.2 Connections	23
5.2.1 Mechanical connection.....	23
5.2.2 Pneumatic connections	25
5.3 Mounting the sensor.....	27
5.3.1 Overview of sensors	27
5.3.2 Sensor monitoring range	27
5.3.3 Settings for magnetic switch.....	28
5.3.4 Switch-off hysteresis for magnetic switch MMS-P 22	29
5.3.5 Assembly and setup of the MMS-P 22.....	30
5.3.6 Inductive monitoring via IN 40.....	32
5.4 Mounting a customized construction	36
6 Commissioning	37
6.1 Adjusting the end positions.....	37
6.2 Setting the speed	40
6.3 Restart after long standstill	40
7 Troubleshooting	41
7.1 Product does not achieve the opening and closing times	41
7.2 Swivel movement is not executed immediately.....	41
8 Maintenance	43
8.1 Notes.....	43
8.2 Maintenance and care intervals	43
8.3 Lubricant/greasing areas/adhesives	44
8.4 Screw tightening torques	46
8.5 Disassembly/assembly of the unit in the basic modules	47
8.6 Disassembly/assembly of the gripping module.....	48
8.6.1 Changing the gripping module – GSM-P 32	48
8.6.2 Changing the gripping module – GSM-P 40-64.....	50
8.6.3 Mounting orientation of the magnets, item 120	51
8.7 Disassembly/assembly of the DKM feed-through compact module (item 40)	51
8.8 Replacing a shock absorber for S variants	53
8.9 Replacing an elastomer for E variants	54
8.10 Disassembly/assembly of the FAN rotor drive (50)	55
8.11 Servicing and assembling the product	56
8.12 Drawings.....	57
8.12.1 Assembly drawing of the basic module	57
8.12.2 Assembly drawing of the DKM and FAN modules	58
8.12.3 Assembly drawing of the gripping modules.....	59

9 Translation of the original declaration of incorporation	60
10 UKCA declaration of incorporation	61
11 Information on the RoHS Directive, REACH Regulation and Substances of Very High Concern (SVHC)	62

1 General

1.1 About this manual

This manual contains important information for a safe and appropriate use of the product.

This manual is an integral part of the product and must be kept accessible for the personnel at all times.

Before starting work, the personnel must have read and understood this operating manual. Prerequisite for safe working is the observance of all safety instructions in this manual.

In addition to these instructions, the documents listed under ▶ 1.1.2 [📄 7] are applicable.

NOTE: The illustrations in this manual are intended to provide a basic understanding and may deviate from the actual version.

1.1.1 Presentation of Warning Labels

To make risks clear, the following signal words and symbols are used for safety notes.



⚠ DANGER

Dangers for persons!

Non-observance will inevitably cause irreversible injury or death.



⚠ WARNING

Dangers for persons!

Non-observance can lead to irreversible injury and even death.



⚠ CAUTION

Dangers for persons!

Non-observance can cause minor injuries.

CAUTION

Material damage!

Information about avoiding material damage.

1.1.2 Applicable documents

- General terms of business *
- Catalog data sheet of the purchased product *
- Assembly and operating manuals of the accessories *

Die mit Stern (*) gekennzeichneten Unterlagen können unter [schunk.com/downloads](https://www.schunk.com/downloads) heruntergeladen werden.

1.1.3 Sizes

This operating manual applies to the following sizes:

- GSM-P 32
- GSM-P 40
- GSM-P 50
- GSM-P 64

1.1.4 Variants

This operating manual applies to the following variations:

- GSM-P without gripping force maintenance
- GSM-P with gripping force maintenance "O.D. gripping" (AS)
- GSM-P with gripping force maintenance "I.D. gripping" (IS)

1.2 Warranty

If the product is used as intended, the warranty is valid for 24 months from the ex-works delivery date under the following conditions:

- Observe the specified maintenance and lubrication intervals
- Observe the ambient conditions and operating conditions

Parts touching the workpiece and wear parts are not included in the warranty.

1.3 Scope of delivery

The scope of delivery includes

- Rotary gripping module with parallel gripper GSM-P in the version ordered
- Assembly and Operating Manual
- Accessory pack

1.3.1 Accessory pack rotational speed rotor FAN

Position of the item numbers, ► 8.12 [57]

Content of the accessory pack:

- Centering sleeves (205 or 206)
- O-rings (207)
- Steel balls (108)
- Locking screws (230)
- Screws (231 / 232)

Rotor drive	ID number
FAN 40	5514441
FAN 64	5514442

1.4 Accessories

A wide range of accessories are available for this product
For information regarding which accessory articles can be used with the corresponding product variants, see catalog data sheet.

1.4.1 Seal kit

Seal kits contain all seals necessary for maintaining a SCHUNK component.

Seal kit for	ID.-No. of the seal kit
GSM-P 32	5516260
GSM-P 40	5516261
GSM-P 50	5516262
GSM-P 64	5516263
FAN 40	5516256
FAN 64	5516257

contents of the sealing kit, ► 8.12 [57].

1.4.2 Spare parts packages

Spare parts packages allow for the maintenance and repair of individual components. For information on the range of the spare parts packages, see www.schunk.com > Service.

The following spare parts packages are available for this product:

- "Rotary gripping module" spare parts package

Contents of the spare parts package, ► 8.12.3 [59].

Rotary gripping module

Spare part kit for	ID number	ID number "O.D. gripping" (AS)	ID number "I.D. gripping" (IS)
GSM-P 32 E-090 / S-090	1339350	1339356	1339352
GSM-P 32 E-180 / S-180	1380461	1380462	1380463
GSM-P 40 E-090 / S-090	1339357	1339362	1339359
GSM-P 40 E-180 / S-180	1380464	1380467	1380470
GSM-P 50 E-090 / S-090	1339363	1339368	1339366
GSM-P 50 E-180 / S-180	1380473	1380476	1380479
GSM-P 64 E-090 / S-090	1339373	1339378	1339376
GSM-P 64 E-180 / S-180	1380483	1380487	1380490

2 Basic safety notes

2.1 Intended use

The product was designed for swiveling, gripping and time-limited holding of workpieces or other objects.

The functions "actuate gripper" and "swivel" must be executed alternately.

- The product may only be used within the scope of its technical data, ▶ 3 [19].
- When implementing and operating components in safety-related parts of the control systems, the basic safety principles in accordance with DIN EN ISO 13849-2 apply. The proven safety principles in accordance with DIN EN ISO 13849-2 also apply to categories 1, 2, 3 and 4.
- The product is intended for installation in a machine/automated system. The applicable guidelines for the machine/automated system must be observed and complied with.
- The product is intended for industrial and industry-oriented use.
- Appropriate use of the product includes compliance with all instructions in this manual.

2.2 Not intended use

It is not intended use if the product is used, for example, as a pressing tool, stamping tool, lifting gear, guide for tools, cutting tool, clamping device or a drilling tool.

- Any utilization that exceeds or differs from the appropriate use is regarded as misuse.

2.3 Constructional changes

Implementation of structural changes

Modifications, changes or reworking, e.g. additional threads, holes, or safety devices, can damage the product or impair its functionality or safety.

- Structural changes should only be made with the written approval of SCHUNK.

2.4 Spare parts

Use of unauthorized spare parts

Using unauthorized spare parts can endanger personnel and damage the product or cause it to malfunction.

- Use only original spare parts or spares authorized by SCHUNK.

2.5 Gripper fingers

Requirements of gripper fingers

Accumulated energy can make the product unsafe and risk the danger of serious injuries and considerable material damage.

- Execute the gripper fingers in such a way that the product reaches either the "open" or "closed" position in a de-energized state.
- Only change gripper fingers if no residual energy can be released.
- Make sure that the product and the top jaws are a sufficient size for the application.

2.6 Ambient conditions and operating conditions

Required ambient conditions and operating conditions

Incorrect ambient and operating conditions can make the product unsafe, leading to the risk of serious injuries, considerable material damage and/or a significant reduction to the product's life span.

- Make sure that the product is used only in the context of its defined application parameters, ▶ 3 [📄 19].

2.7 Personnel qualification

Inadequate qualifications of the personnel

If the personnel working with the product is not sufficiently qualified, the result may be serious injuries and significant property damage.

- All work may only be performed by qualified personnel.
- Before working with the product, the personnel must have read and understood the complete assembly and operating manual.
- Observe the national safety regulations and rules and general safety instructions.

The following personal qualifications are necessary for the various activities related to the product:

Trained electrician	Due to their technical training, knowledge and experience, trained electricians are able to work on electrical systems, recognize and avoid possible dangers and know the relevant standards and regulations.
Qualified personnel	Due to its technical training, knowledge and experience, qualified personnel is able to perform the delegated tasks, recognize and avoid possible dangers and knows the relevant standards and regulations.
Instructed person	Instructed persons were instructed by the operator about the delegated tasks and possible dangers due to improper behaviour.
Service personnel of the manufacturer	Due to its technical training, knowledge and experience, service personnel of the manufacturer is able to perform the delegated tasks and to recognize and avoid possible dangers.

2.8 Personal protective equipment

Use of personal protective equipment

Personal protective equipment serves to protect staff against danger which may interfere with their health or safety at work.

- When working on and with the product, observe the occupational health and safety regulations and wear the required personal protective equipment.
- Observe the valid safety and accident prevention regulations.
- Wear protective gloves to guard against sharp edges and corners or rough surfaces.
- Wear heat-resistant protective gloves when handling hot surfaces.
- Wear protective gloves and safety goggles when handling hazardous substances.
- Wear close-fitting protective clothing and also wear long hair in a hairnet when dealing with moving components.

2.9 Notes on safe operation

Incorrect handling of the personnel

Incorrect handling and assembly may impair the product's safety and cause serious injuries and considerable material damage.

- Avoid any manner of working that may interfere with the function and operational safety of the product.
- Use the product as intended.
- Observe the safety notes and assembly instructions.
- Do not expose the product to any corrosive media. This does not apply to products that are designed for special environments.
- Eliminate any malfunction immediately.
- Observe the care and maintenance instructions.
- Observe the current safety, accident prevention and environmental protection regulations regarding the product's application field.

2.10 Transport

Handling during transport

Incorrect handling during transport may impair the product's safety and cause serious injuries and considerable material damage.

- When handling heavy weights, use lifting equipment to lift the product and transport it by appropriate means.
- Secure the product against falling during transportation and handling.
- Stand clear of suspended loads.

2.11 Malfunctions

Behavior in case of malfunctions

- Immediately remove the product from operation and report the malfunction to the responsible departments/persons.
- Order appropriately trained personnel to rectify the malfunction.
- Do not recommission the product until the malfunction has been rectified.
- Test the product after a malfunction to establish whether it still functions properly and no increased risks have arisen.

2.12 Disposal

Handling of disposal

The incorrect handling of disposal may impair the product's safety and cause serious injuries as well as considerable material and environmental harm.

- Follow local regulations on dispatching product components for recycling or proper disposal.

2.13 Fundamental dangers

General

- Observe safety distances.
- Never deactivate safety devices.
- Before commissioning the product, take appropriate protective measures to secure the danger zone.
- Disconnect power sources before installation, modification, maintenance, or calibration. Ensure that no residual energy remains in the system.
- If the energy supply is connected, do not move any parts by hand.
- Do not reach into the open mechanism or movement area of the product during operation.

2.13.1 Protection during handling and assembly

Incorrect handling and assembly

Incorrect handling and assembly may impair the product's safety and cause serious injuries and considerable material damage.

- Have all work carried out by appropriately qualified personnel.
- For all work, secure the product against accidental operation.
- Observe the relevant accident prevention rules.
- Use suitable assembly and transport equipment and take precautions to prevent jamming and crushing.

Incorrect lifting of loads

Falling loads may cause serious injuries and even death.

- Stand clear of suspended loads and do not step into their swiveling range.
- Never move loads without supervision.
- Do not leave suspended loads unattended.

2.13.2 Protection during commissioning and operation

Falling or violently ejected components

Falling and violently ejected components can cause serious injuries and even death.

- Take appropriate protective measures to secure the danger zone.
- Never step into the danger zone during operation.

2.13.3 Protection against dangerous movements

Unexpected movements

Residual energy in the system may cause serious injuries while working with the product.

- Switch off the energy supply, ensure that no residual energy remains and secure against inadvertent reactivation.
- Never rely solely on the response of the monitoring function to avert danger. Until the installed monitors become effective, it must be assumed that the drive movement is faulty, with its action being dependent on the control unit and the current operating condition of the drive. Perform maintenance work, modifications, and attachments outside the danger zone defined by the movement range.
- To avoid accidents and/or material damage, human access to the movement range of the machine must be restricted. Limit/prevent accidental access for people in this area due through technical safety measures. The protective cover and protective fence must be rigid enough to withstand the maximum possible movement energy. EMERGENCY STOP switches must be easily and quickly accessible. Before starting up the machine or automated system, check that the EMERGENCY STOP system is working. Prevent operation of the machine if this protective equipment does not function correctly.

2.13.4 Protection against electric shock

Possible electrostatic energy

Components or assembly groups may become electrostatically charged. When the electrostatic charge is touched, the discharge may trigger a shock reaction leading to injuries.

- The operator must ensure that all components and assembly groups are included in the local potential equalisation in accordance with the applicable regulations.
- While paying attention to the actual conditions of the working environment, the potential equalisation must be implemented by a specialist electrician according to the applicable regulations.
- The effectiveness of the potential equalisation must be verified by executing regular safety measurements.

2.14 Notes on particular risks



⚠ DANGER

Risk of fatal injury from suspended loads!

Falling loads can cause serious injuries and even death.

- Stand clear of suspended loads and do not step within their swiveling range.
- Never move loads without supervision.
- Do not leave suspended loads unattended.
- Wear suitable protective equipment.



⚠ WARNING

Risk of injury from objects falling and being ejected!

Falling and ejected objects during operation can lead to serious injury or death.

- Take appropriate protective measures to secure the danger zone.



⚠ WARNING

Risk of injury due to unexpected movements!

If the power supply is switched on or residual energy remains in the system, components can move unexpectedly and cause serious injuries.

- Before starting any work on the product: Switch off the power supply and secure against restarting.
- Make sure, that no residual energy remains in the system.



⚠ WARNING

Risk of injury from crushing and impacts!

Serious injury could occur during movement of the base jaw, due to breakage or loosening of the gripper fingers or if the workpiece is lost.

- Wear suitable protective equipment.
- Do not reach into the open mechanism or the movement area of the product.



⚠ WARNING

Risk of injury due to spring forces!

Parts are under spring tension on products which clamp using spring force or which have gripping force maintenance. While disassembling components can move unexpectedly and cause serious injuries.

- Disassemble the product cautiously.
- Make sure that no residual energy remains in the system.



⚠ WARNING

Risk of injury from objects falling during energy supply failure

Products with a mechanical gripping force maintenance can, during energy supply failure, still move independently in the direction specified by the mechanical gripping force maintenance.

- Secure the end positions of the product with SCHUNK SDV-P pressure maintenance valves.



⚠ WARNING

Risk of injury due to sudden movements!

During operation, due to incorrect actuation and in the event of a power failure, falling and ejected objects can cause serious injuries.

- Carry out safety measures in the user program.
- Take suitable protective measures to secure the danger zone/ product.



⚠ WARNING

Risk of injury from rotating components!

In the case of swivel units or rotary tables with a rotary drive, serious injuries can be caused by rotating components.

- Take appropriate protective measures to secure the danger zone.



⚠ WARNING

Risk of injury from loosened parts!

Due to damaged shock absorbers, parts may be loosened which destroy the swivel unit and in this way may cause serious injuries.

- Regular inspection of the individual components on wear and damage.



⚠ WARNING

Risk of injury due to contact with lubricants!

Lubricant may cause irritation and allergic reactions if it contacts the skin or eyes.

- Avoid contact between lubricant and skin or eyes.
- Wear safety goggles and protective gloves.
- Observe information on the safety data sheet of the lubricant.

3 Technical data

Designation	GSM-P 32	GSM-P 40	GSM-P 50	GSM-P 64
IP rating			30	
Noise emission [dB(A)]			≤ 70	
Pressure medium	Compressed air, compressed air quality according to ISO 8573-1:2010 [7:4:4]			
Nominal working pressure [bar]			6	
Min. pressure [bar] for gripping without gripping force maintenance with gripping force maintenance			2 4	
Min. pressure [bar] for swiveling	3.5	4		3
Max. pressure [bar]			6.5	

More technical data is included in the catalog data sheet.
Whichever is the latest version.

4 Design and description

4.1 Design

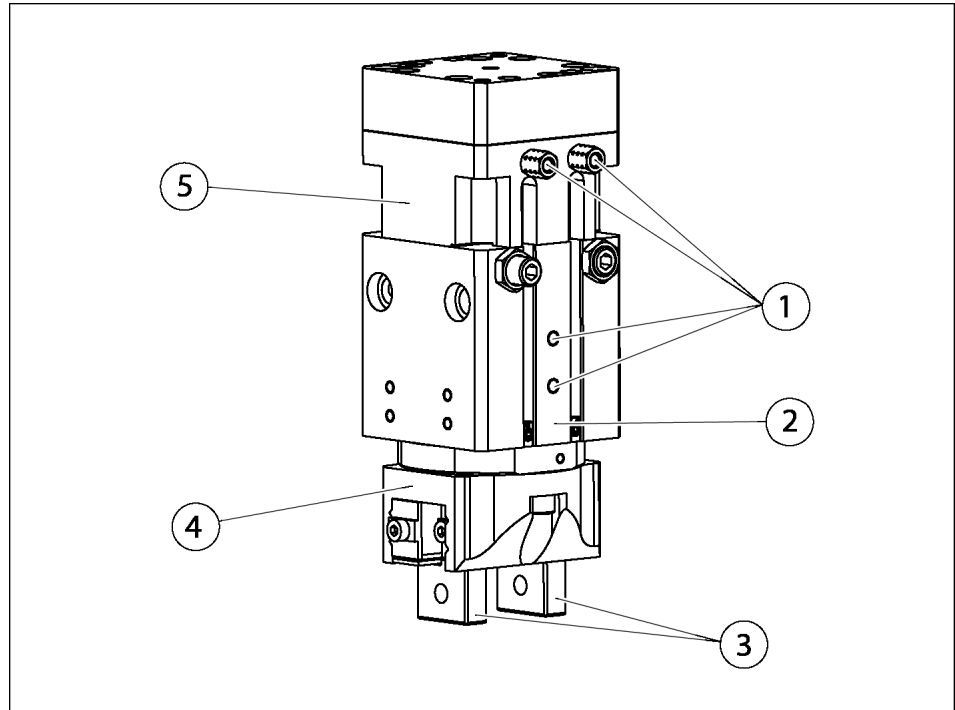

Rotary gripping module with parallel gripper

1	Compressed air main connection
2	DKM feed-through compact module
3	Base jaws
4	PGM gripping module
5	FAN rotor drive

4.2 Description

Rotary gripping module with parallel gripper

5 Assembly

5.1 Installing and connecting



⚠ WARNING

Risk of injury due to unexpected movements!

If the power supply is switched on or residual energy remains in the system, components can move unexpectedly and cause serious injuries.

- Before starting any work on the product: Switch off the power supply and secure against restarting.
- Make sure, that no residual energy remains in the system.

CAUTION

Damage to the gripper is possible!

If the maximum permissible finger weight or the permissible mass moment of inertia of the fingers is exceeded, the gripper can be damaged.

- A jaw movement always has to be without jerks and bounce.
- You must therefore implement sufficient reduction and/or damping.
- Observe the information in the catalog data sheet.

NOTE

- Observe the requirements for the compressed air supply, ▶ 3 [19].
- In case of compressed air loss (cutting off the energy line), the components lose their dynamic effects and do not remain in a secure position. However, the use of a SDV-P pressure maintenance valve is recommended in this case in order to maintain the dynamic effect for some time. Product variants are also offered with mechanical gripping force via springs, which also ensure a minimum clamping force in the event of a pressure drop.

1. Check the evenness of the mounting surface, ▶ 5.2.1 [23].
2. Only open the required air connections (main connection or direct connection), ▶ 5.2.2 [25].

- 3.** Connect the product via the hose-free direct connection.
 - ⇒ Use O-rings from the accessory pack.
 - ⇒ Seal main air connections which are not required with locking screws.
- 4.** OR: Connect compressed air lines to the main air connections "A" and "B".
 - ⇒ Screw in air connections (plug connections).
OR: Screw on throttle valve in order to be able to perform sufficient throttling and/or damping.
- 5.** Screw the product to the machine/system, ▶ [5.2.1 \[23\]](#).
 - ⇒ If necessary, use appropriate connection elements (adapter plates).
 - ⇒ Observe the maximal tightening torque, admissible screw-in depth and, if necessary, strength class.
 - ⇒ When mounting from the rear or at the side: use cylindrical pins for fixing the product in place.
- 6.** Secure the gripper fingers to the base jaws, ▶ [5.2.1 \[23\]](#).
 - ⇒ Use centering sleeves from the enclosed accessory pack.
- 7.** Connect air purge connection if necessary.
- 8.** Connect the sensor, see assembly and operating manual of the sensor.
- 9.** Mount the sensor, ▶ [5.3 \[27\]](#).

5.2 Connections

5.2.1 Mechanical connection

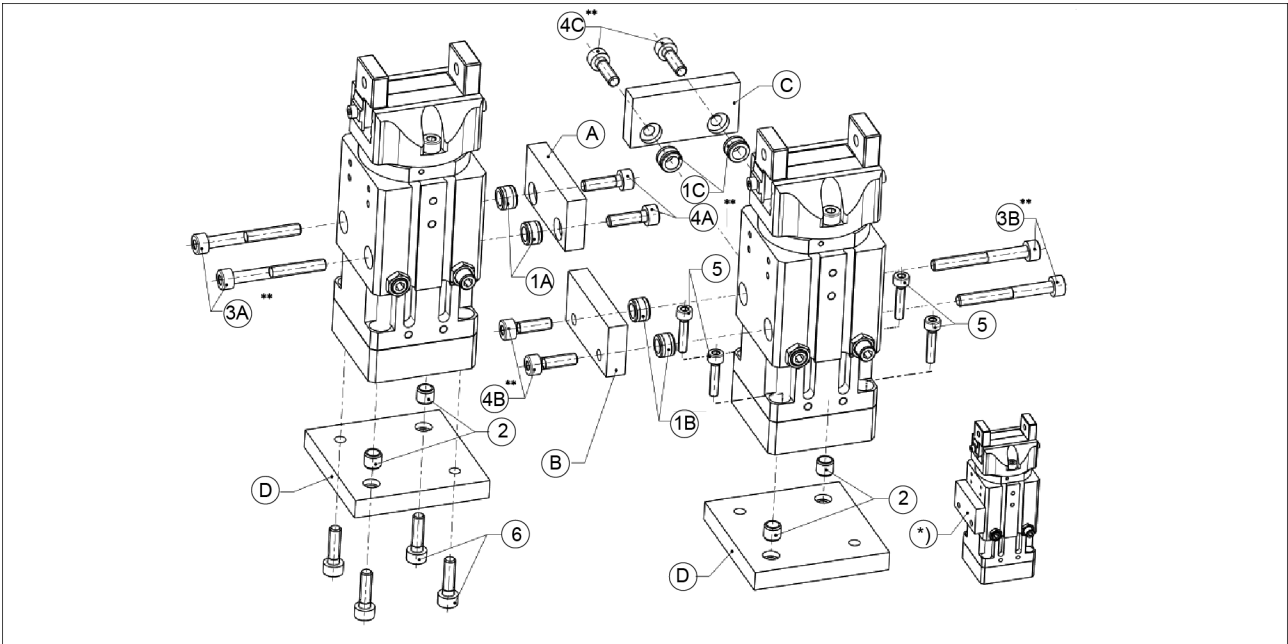

Mounting the GSM on the side and base side

- * To ensure the function of the sensors, the A2 screws from the accessory pack are to be used.
- * To ensure the function of the sensors, the A2 screws from the accessory pack are to be used.

For process-reliable monitoring, adapter plates should be made of non-ferromagnetic material.

Item	GSM - SFL basic size	40	64
1A	Centering sleeve for lateral mounting of the unit and fitting depth in the mounting plate	Ø8	Ø10
1B		2.5 deep	3 deep
1C		Item 206	Item 205
2	Centering sleeve for mounting the unit on the base side and fitting depth in the mounting plate	Ø6	Ø10
		2.5 deep	3 deep
		Item 205	Item 205
3A	Thread diameter for screwing through for mounting the unit at the side	M4	M5
3B		Item 232	Item 232
3C			
4A	Thread diameter and max. depth of engagement for screw connection for lateral mounting	M5	M6
4B		19 deep	25 deep
4C		Item 231	Item 231
5	Thread diameter for screwing through for mounting the unit on the base side	M3	M5
6	Thread diameter and maximum depth of engagement for screw connection for mounting on the base side	M4 8 deep	M6 11 deep

Mounting the unit

Mounting the unit on the base side

(with adapter plate similar to A, B or C; see "Mounting the GSM at the side and on the base side")

The assembly of the unit can be carried out from the side of the unit using the screws (6).

There are threads in the housings for mounting from the customer-specific opposite side (screws 5 and 6 are not included in the scope of delivery).

Use the centering sleeves (2) for the secure transmission of lateral forces and the positioning of the unit.

Mounting the unit at the side

(with adapter plate similar to A, B or C)

The assembly of the unit can be carried out from the side of the unit using the A2 screws included in the accessory kit (3A, 3B or 3C).

There are threads in the housings for mounting from the customer-specific opposite side. (The A2 screws (4A, 4B or 4C) are included in the accessory kit.)

Use the centering sleeves (1A, 1B or 1C) for the secure transmission of lateral forces and positioning of the unit.

NOTE

In order to guarantee process reliability for monitoring with magnetic switches, the adapter plate and the attachments located near the unit in particular should be made of non-ferromagnetic material. Otherwise, monitoring with magnetic sensors could be impaired considerably.

NOTE

When monitoring with magnetic switches, the minimum distance between the units must be 10 mm if multiple units are installed next to each other.

5.2.2 Pneumatic connections



⚠ WARNING

Risk of injury during connection!

- Switch off the energy supply.

CAUTION

The central air unit must be equipped with a maintenance unit that is located as near as possible to the consumer.

CAUTION

If the end positions of the stroke and swivel movements are not impact-free and bounce-free, the respective movements must be adjusted with the exhaust throttle.

CAUTION

Observe the requirements for the air supply, ▶ 3 [d 19].

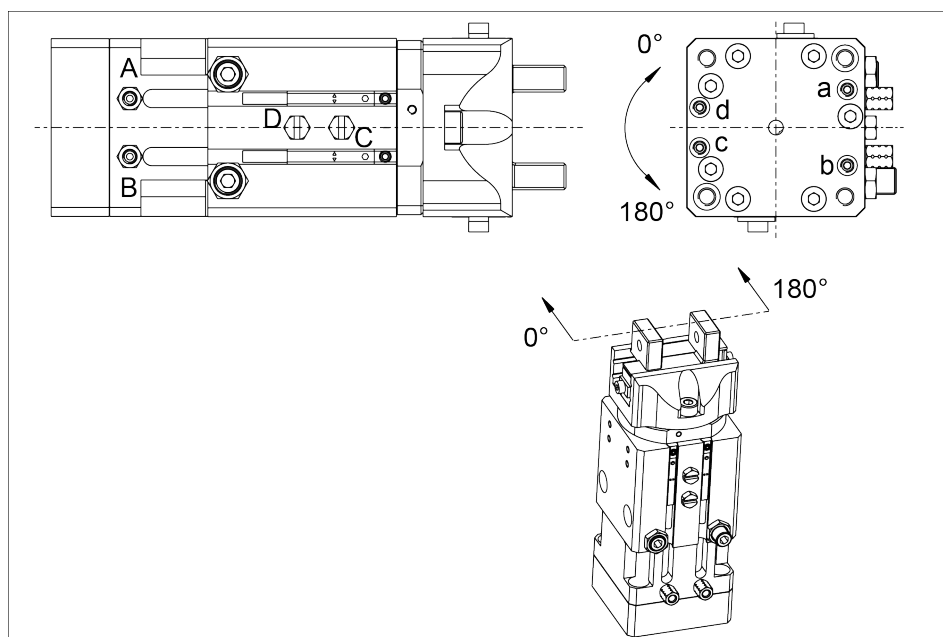

Pneumatic connections

"A" - "D" are main connections, "a" - "d" are direct connections

Connection	Function
Hose connection A	Swivel toward 180° or 90° position
Hose-free direct connection a	
Hose connection B	Swivel toward 0° position
Hose-free direct connection b	
Hose connection C	Move gripper into »OPEN« position
Hose-free direct connection c	
Hose connection D	Move gripper into »CLOSED« position
Hose-free direct connection d	

Connections "C" and "D" for the modules with a base cross section of 25x25 are slightly offset from center

If direct connections "a" - "d" are used, use the locking screws included in the accessory pack for the corresponding main connections "A" - "D".

If air connections "a" - "d" are used, ensure sufficient throttling, which can be set by means of exhaust air throttling. To do this, the throttle reductions for the main connections, which are designed for a medium load, can be attached to the adapter plate, for example.

- Open only the air connections that are needed.
- Close unused main air connections using the screw plugs from the enclosed pack.
- For a hose-free direction connection, use the O-rings from the enclosed pack.

5.3 Mounting the sensor

NOTE

Observe the assembly and operating manual of the sensor for mounting and connecting.

The product is prepared for the use of sensors.

- For the exact type designations of suitable sensors, please see catalog datasheet and ▶ 5.3.1 [27].
- For technical data for the suitable sensors, see assembly and operating manual and catalog datasheet.
 - The assembly and operating manual and catalog datasheet are included in the scope of delivery for the sensors and are available at schunk.com.
- Information on handling sensors is available at schunk.com or from SCHUNK contact persons.

5.3.1 Overview of sensors

Designation	GSM-P			
	32	40	50	64
Programmable magnetic switch MMS-P 22	X	X	X	X
Inductive proximity switch IN 40	X	X	X	X

5.3.2 Sensor monitoring range

NOTE

The monitoring of swiveling and grasping movements with an inductive proximity switch and magnetic switch can yield reliable results only in the ranges of $0^\circ \pm 3^\circ$ and $180^\circ \pm 3^\circ$ or $0^\circ \pm 3^\circ$ and $90^\circ \pm 3^\circ$.

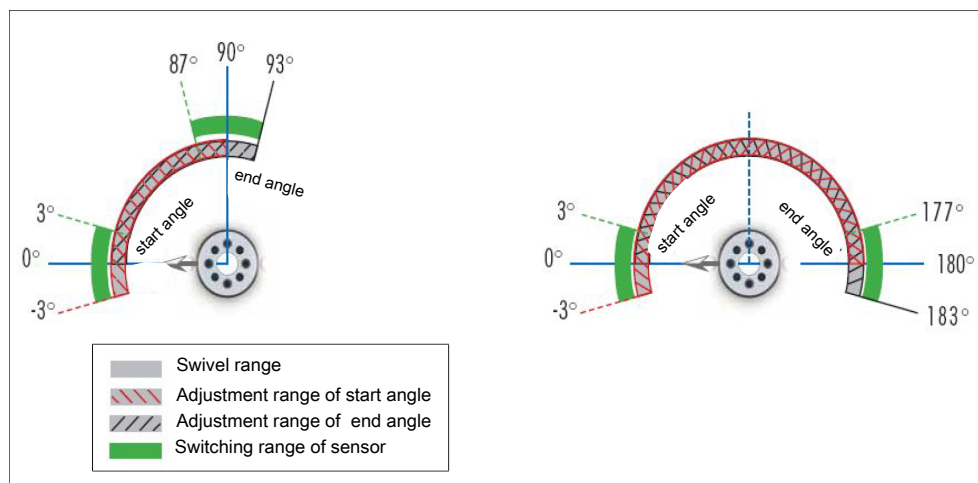

Rotating angle setting and monitoring range GSM

5.3.3 Settings for magnetic switch

NOTE

The installation dimensions shown only apply if the clamping position of the sensor is not specified by a T-nut.

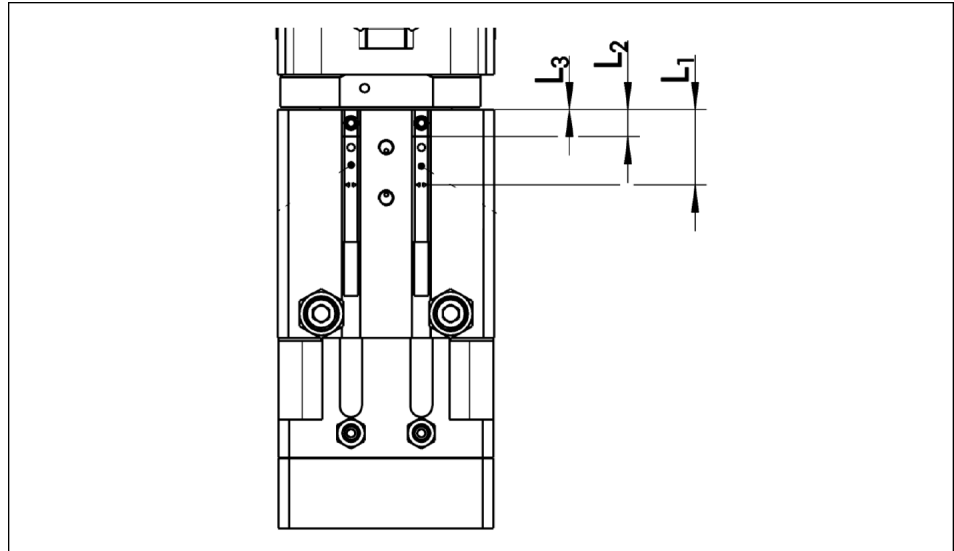

GSM Type	Dimension L1	Dimension L2	Dimension L3
GSM-P-32	8.9	0	-
GSM-P-32-AS	8.9	0	-
GSM-P-32-IS	20.05	11.15	6.15
GSM-P-40	13.9	5	0
GSM-P-40-AS	13.9	5	0
GSM-P-40-IS	31.5	22.6	17.6
GSM-P-50	16.9	8	3
GSM-P-50-AS	16.9	8	3
GSM-P-50-IS	36.7	27.8	23
GSM-P-64	13.9	5	0
GSM-P-64-AS	13.9	5	0
GSM-P-64-IS	26.25	16.35	11.35

Tab.: Installation dimensions for MMS-P

5.3.4 Switch-off hysteresis for magnetic switch MMS-P 22

The smallest detectable difference in stroke is defined in the following table:

For grippers with X mm nominal stroke per jaw	Min. query range per jaw/ min. queried stroke difference per jaw
$X \leq 5 \text{ mm}$	60% of the nominal stroke per jaw
$X > 5 \text{ mm to } X \leq 10 \text{ mm}$	40% of the nominal stroke per jaw
$X > 10 \text{ mm}$	20% of the nominal stroke per jaw

Tab.: The smallest detectable difference in stroke based on the nominal stroke

Example: Product with 7 mm nominal stroke per jaw

$7 \text{ mm} * 40\% = 2.8 \text{ mm}$

NOTE

The table of values applies only to sensors whose hysteresis has been taught. For further information see assembly and operating manual of the sensor.

5.3.5 Assembly and setup of the MMS-P 22

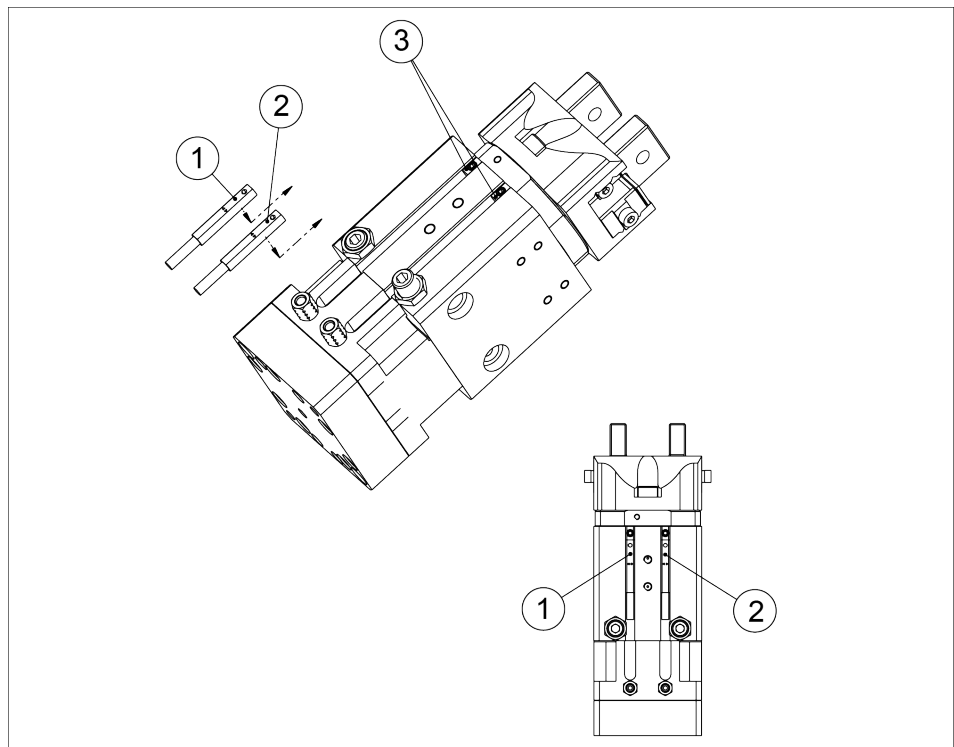

Position and installation of the MMS-P magnetic switches

1	Sensor MMS-P (groove 1)	Monitoring gripper position 1 and gripper position 2 in the left rotating angle end position (signals SGL1 and SGL2)
2	Sensor MMS-P (groove 2)	Monitoring gripper position 1 and gripper position 2 in the right rotating angle end position (signals SGR1 and SGR2)
3	Stop for MMS-P	Determining the clamping position of the MMS-P sensor

Monitoring GSM locations/positions/end positions:

SGL1: left rotating angle end position, gripper position 1

SGL2: left rotating angle end position, gripper position 2

SGR1: right rotating angle end position, gripper position 1

SGR2: right rotating angle end position, gripper position 2

2 gripper positions can be monitored by each of the two MMS-P sensors. If the gripper is in a third gripper position, the rotating angle end position can only be monitored via additional sensors.

- The left rotating angle end position is always reached when a switching point of the sensor of the left groove (SGL1 or SGL2) is active.
- The right rotating angle end position is always reached when a switching point of the sensor of the right groove (SGR1 or SGR2) is active.

The sequence of rotating and closing movements (process sequence) defined during the teaching procedure must not be changed during operation. Otherwise, incorrect sensor signals may be output.

With many GSM variants, it is possible to combine magnetic switch monitoring with inductive monitoring, ► [5.3.6 \[32\]](#).

- If you require further information on sensor operation, contact your SCHUNK contact person or download information from our homepage.
- Technical data for the sensors can be found in the data sheets (included in the scope of delivery).

5.3.6 Inductive monitoring via IN 40

GSM-P Attachment kit for IN 40	ID number
AS-GSM-P-32, attachment kit for IN 40	0304934
AS-GSM-P-40, attachment kit for IN 40	0304935
AS-GSM-P-50, attachment kit for IN 40	0304936
AS-GSM-P-64, attachment kit for IN 40	0304937

Tab.: Attachment kits for IN 40

Schematic diagram of inductive monitoring with IN 40 for sizes 32 and 50 for 90° variants

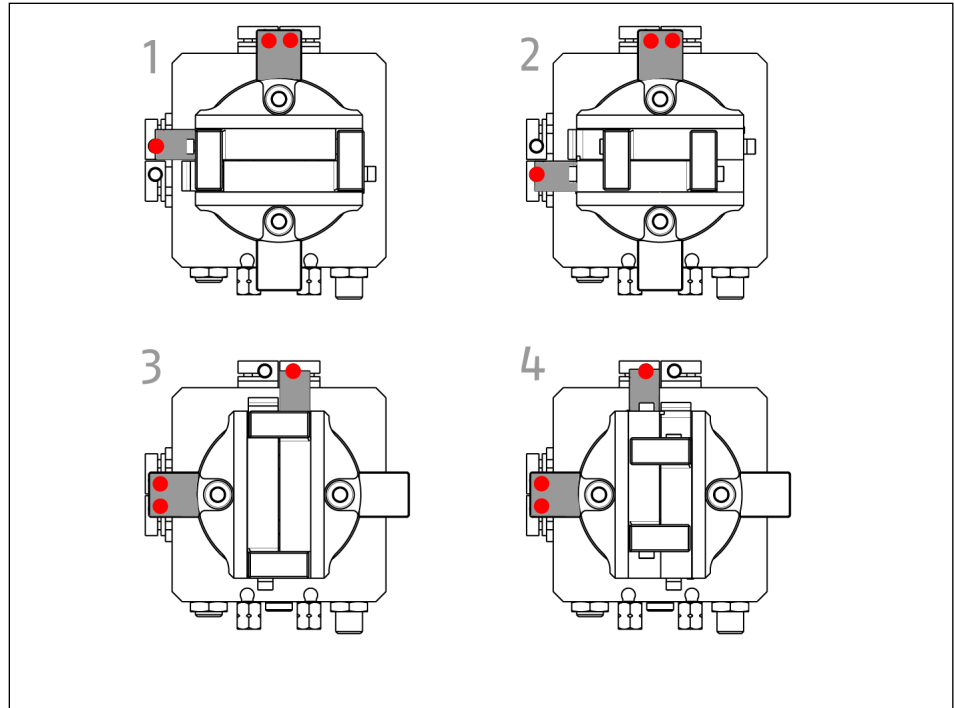

Schematic diagram of inductive monitoring for sizes 32 and 50

Schematic diagram of inductive monitoring with IN 40 for sizes 40 and 64 for 90° variants

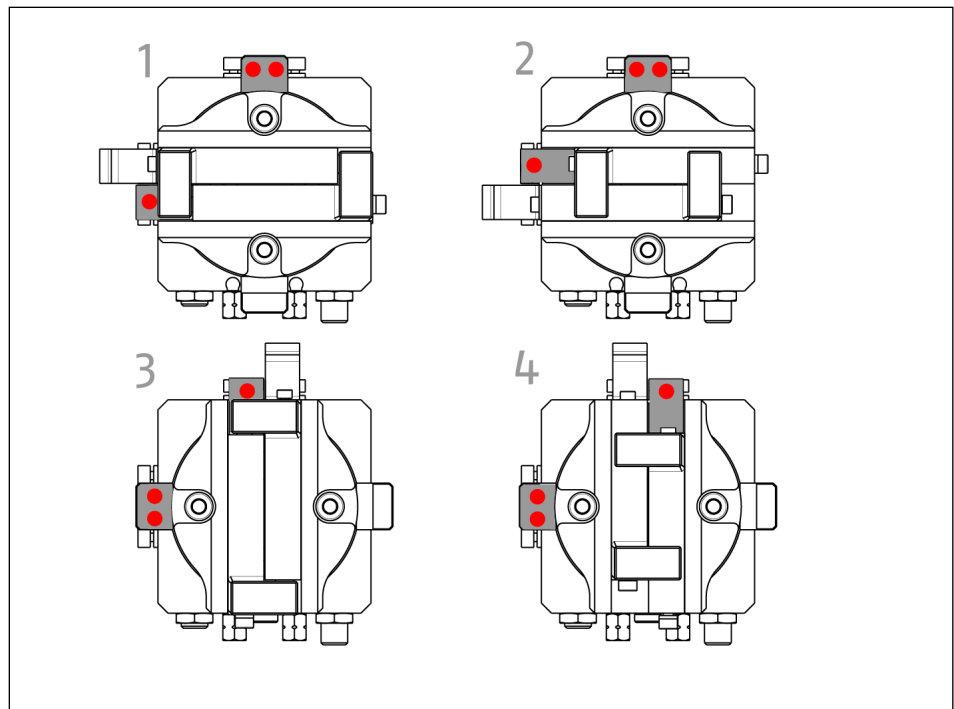

Schematic diagram of inductive monitoring for sizes 40 and 64

Schematic diagram of inductive monitoring with IN 40 for sizes 32 and 50 for 180° variants

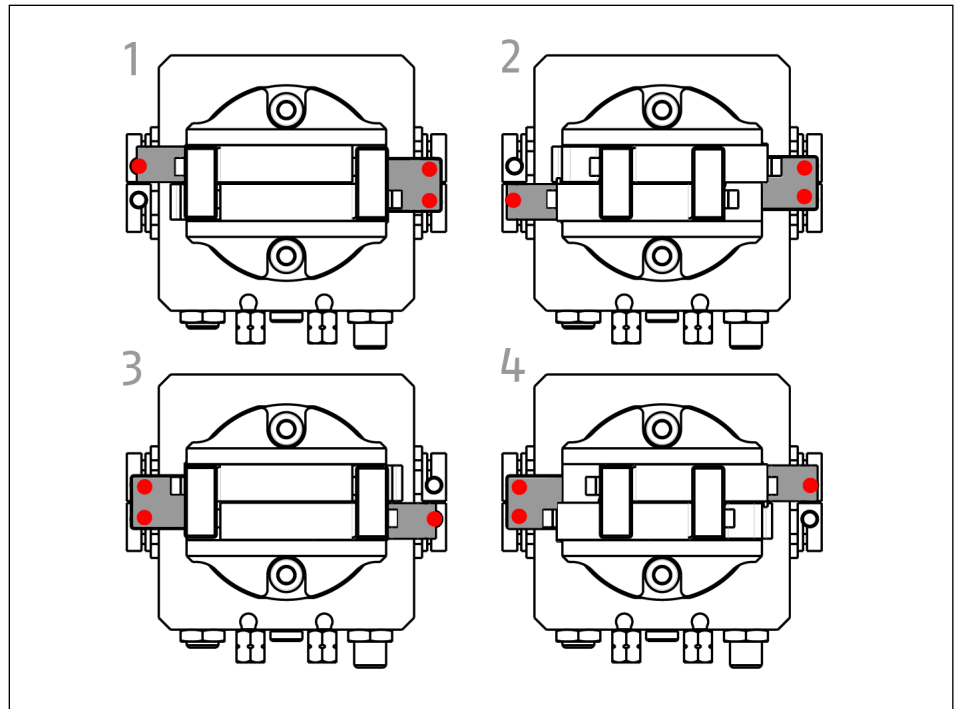

Schematic diagram of inductive monitoring for sizes 32 and 50

Schematic diagram of inductive monitoring with IN 40 for sizes 40 and 64 for 180° variants

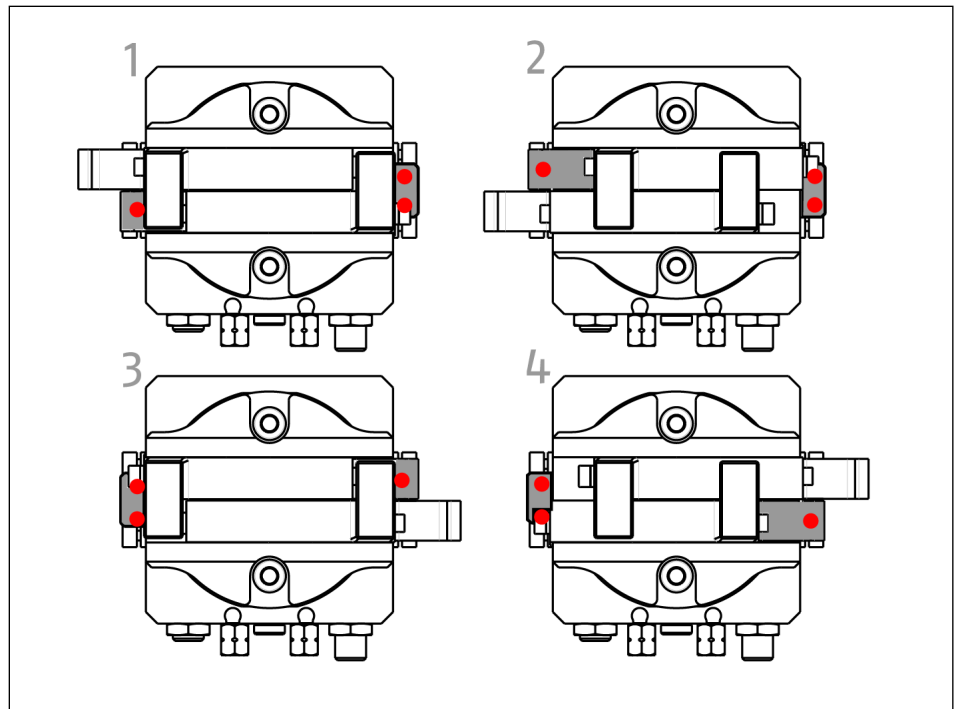

Schematic diagram of inductive monitoring for sizes 40 and 64

● Dampened sensor

■ Switching cam position

- [1] Rotating angle end position in counterclockwise direction with opened gripper
- [2] Rotating angle end position in counterclockwise direction with closed gripper
- [3] Rotating angle end position in clockwise direction with opened gripper
- [4] Rotating angle end position in clockwise direction with closed gripper

NOTE

One of the two inductive proximity switches for the "gripping" monitoring is briefly crossed over during swiveling action by "second switching lug gripping".

CAUTION

The maximum tightening torque for the clamping screws (301 and/or 303) at the holder (300) is 125 Ncm. Remove bracket (8).

CAUTION

Risk of damage due to incorrect adjustment of the proximity switches!

Disconnect the energy supply before installing or adjusting the inductive proximity switches.

Installation steps for assembly of the mounting kit and mounting of the proximity switch

1. Mount the plastic holders (300) onto the designated spaces with the screws (301 and/or 303). Depending on the mounting kit, offset pieces (94) may have to be installed.
2. Remove the retaining plate (8) and the distance plate (7). Mount switching lug(s) grippers (91+92) onto the base jaw which lies in the 0° swivel position exactly above the 0° swivel position.
3. Mount the inductive proximity switch INW 40 into the plastic holders (300).
It is advised to set the switching distance of all four proximity switches under the swiveling switching lug (93).
By gently applying the clamping screws (301 or 303), the proximity switch can be lightly clamped. A feeler gauge tape with a thickness of 0.5 mm can be very helpful as well, because the proximity switch can thus be installed on "blocked/stop", which prevents a collision during a swiveling movement.
4. Move the unit with the energy supply switched off in the respective rotating angle end position and set two of the proximity switches on the swiveling switching lug (93) and tighten the clamping screws (301 or 303).

CAUTION: observe permissible tightening torque.

When setting the switching distances, make sure that none of the switching flags can collide with a proximity switch.

5. Check the function of each proximity switch and check the output signals of the proximity switch by moving to different gripper positions in the two rotating angle end positions with connected energy supply.
6. Should one or more proximity switches not send a signal, repeat step 3 of the setting instructions and slightly reduce the switching distance until the desired function is achieved.
7. Should a signal be received "too early", this can be corrected by increasing the switching distance, which, however, also affects the sensitivity of the switching function.

Assembly of GSM with inductive monitoring with INW 40

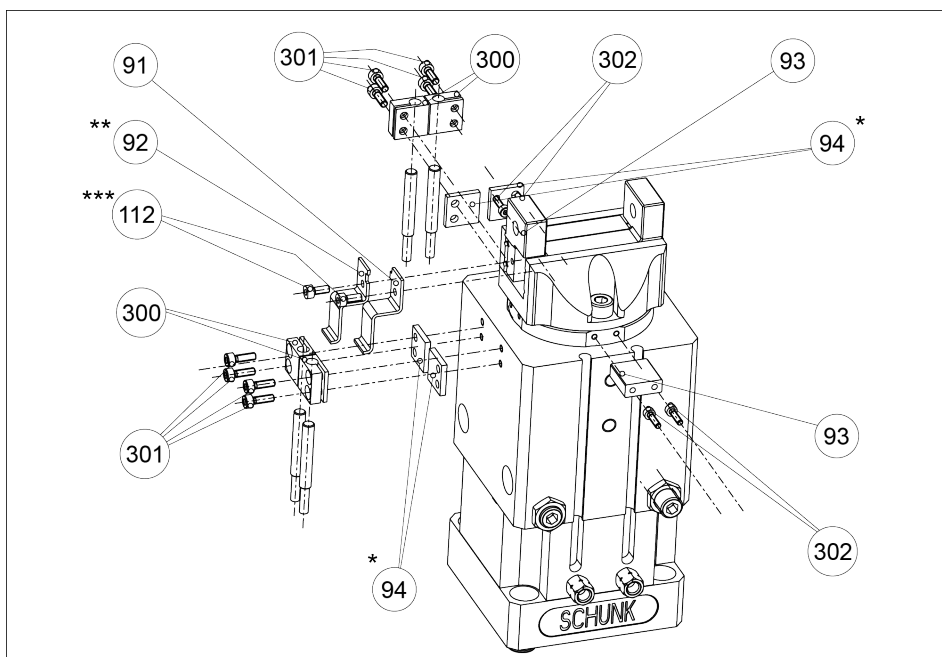

Assembly of GSM 090 variants with inductive monitoring

- * Only included in the mounting kit for P-50
- ** In P-32, item 92 is identical to item 91
- *** Item 112 is not a component of the mounting kit, it is part of the gripping module

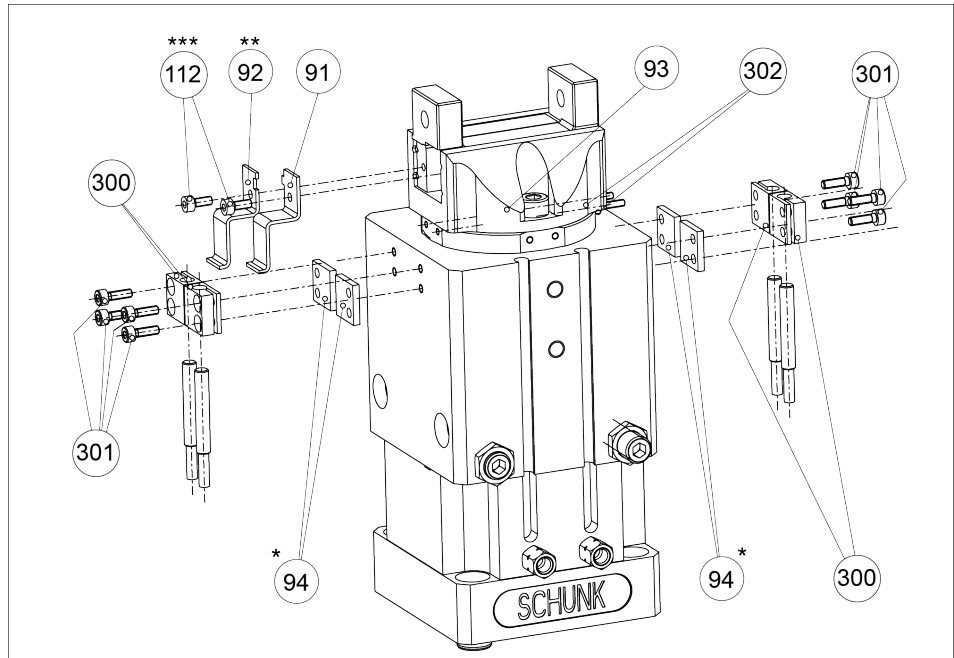

Assembly of GSM 180 variants with inductive monitoring

- * Only included in the mounting kit for P-50
- ** In P-32, item 92 is identical to item 91
- *** Item 112 is not a component of the mounting kit, it is part of the gripping module

5.4 Mounting a customized construction

CAUTION

Damage to the unit during assembly!

When inserting the cylindrical pins or centering sleeves, the unit must not be subjected to any impact.

Mounting of a customized construction to the gripper fingers GSM-P

It is recommended to use the width of the gripper finger which is designed as the fit size for the centering of the customized top jaws. It is also recommended to use the upper contact surface of the gripper finger to support the customized top jaws.

No mounting screws are included in the scope of delivery.

6 Commissioning

CAUTION

Material damage due to faulty settings and assembly.

If the end position is approached too abruptly, the product may be damaged.

- Ensure the turning / swiveling movement is carried out without bouncing or bumping.
- Therefore provide sufficient throttling and damping.
- Please observe the information in the catalog data sheet.

6.1 Adjusting the end positions

Position of the item numbers ▶ 8.12 [57]

Adjustment of the end position for elastomer dampening:

1. Connect connections A and B to the compressed air supply.
2. Actuate connections A and B alternately and allow the unit to swivel.
3. Actuate connection B; the swivel unit will reach the end position in counterclockwise direction.
4. Place the unit sideways on a measuring table with the air connections facing up.
5. Loosen the counter nut (124) and twist the stop (83). To increase the rotating angle range, screw out the stop, but only up to the maximum projection dimension B. (For projection dimensions A and B, see the following table "Total rotation angle range").
When the rotating angle is set, tighten the counter nut (124).
6. Actuate connections A and B alternately and allow the unit to swivel.
7. Check the set rotating angle several times. Repeat steps 5 and 6 until the desired position is reliably reached even after repeated rotation.
8. To set the second end position, proceed according to steps 5 to 7, but actuate connection A.

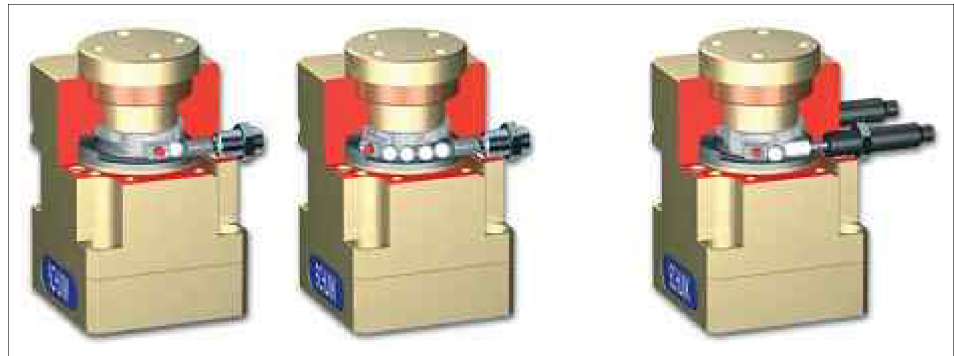

Stepless angular adjustment with balls

For angles between "0°" and "180°" or "0°" and "90°", insert additional steel balls (108) in the ball guide rail. The number of steel balls required and the permissible minimum or maximum projections of the stops, can be determined using the table "Total rotating angle range".

Adjustment of the end position for hydraulic dampening by means of shock absorbers:

Proceed according to steps 1 to 8 of the elastomer dampening. Use the shock absorbers (120) instead of the stops (83) and the shock absorber nut (121) instead of the counter nut (124).

For angles between "0°" and "180°" or "0°" and "90°", insert additional steel balls (108) in the ball guide rail. The number of steel balls required and the permissible minimum or maximum projections, (S variants: shock absorber projections)/(E variants: back stop projections) can be determined using the table "Total rotating angle range".

The ball insertion is described in the following chapters:

- for S variants ▶ 8.8 [53]
- for E variants ▶ 8.9 [54]

CAUTION

The permissible minimum and maximum projections are to be strictly observed; should a rotating angle not be achieved by adjusting the shock absorbers (120) or stops (83), it must be done by inserting or removing steel balls (108). However, at least one ball must be mounted on each side.

Tab.: Total rotating angle range

	Basic size 40	Basic size 64
Standard total rotating angle range		90° or 180°
Minimum rotating angle range	Can be reduced down to 0° for any position within the total rotating angle range of the standard unit	

	Basic size 40	Basic size 64
Angle limitation per ball [°]	19	13.5
Min. projection A [mm], E variants	3	4.5
Max. projection B [mm], E variants	7	9.5
Min. projection A [mm], S variants	19.5	28
Max. projection B [mm], S variants	23.5	33

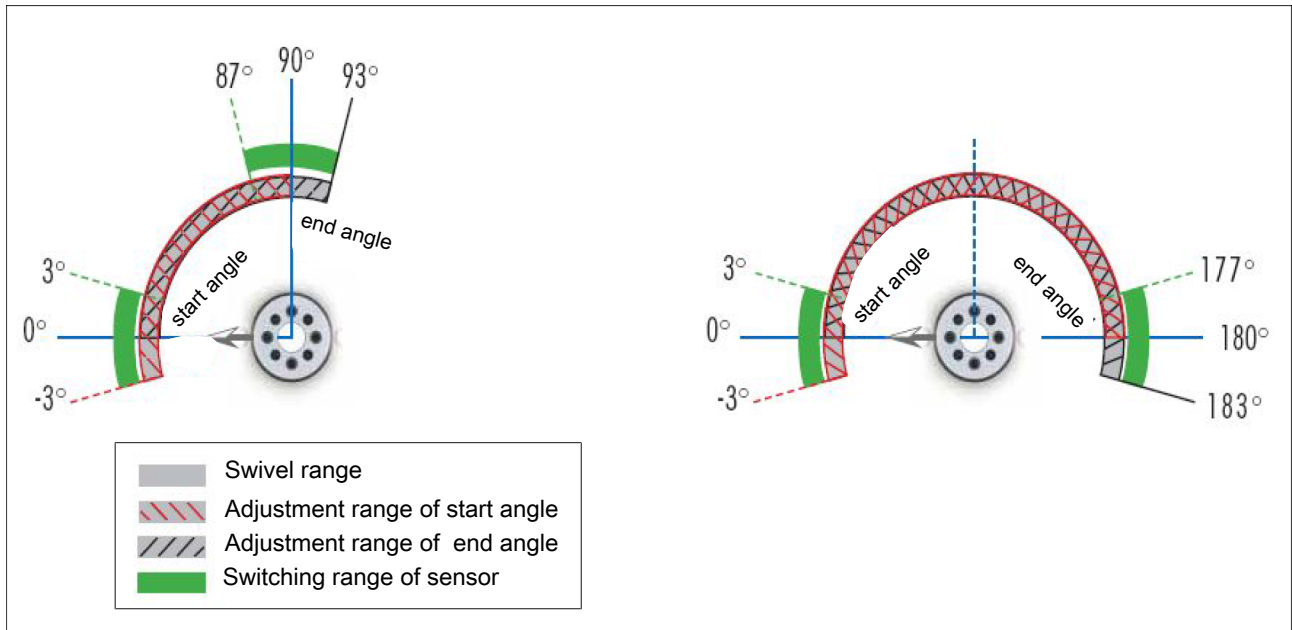

Rotating angle setting and monitoring range with GSM-P

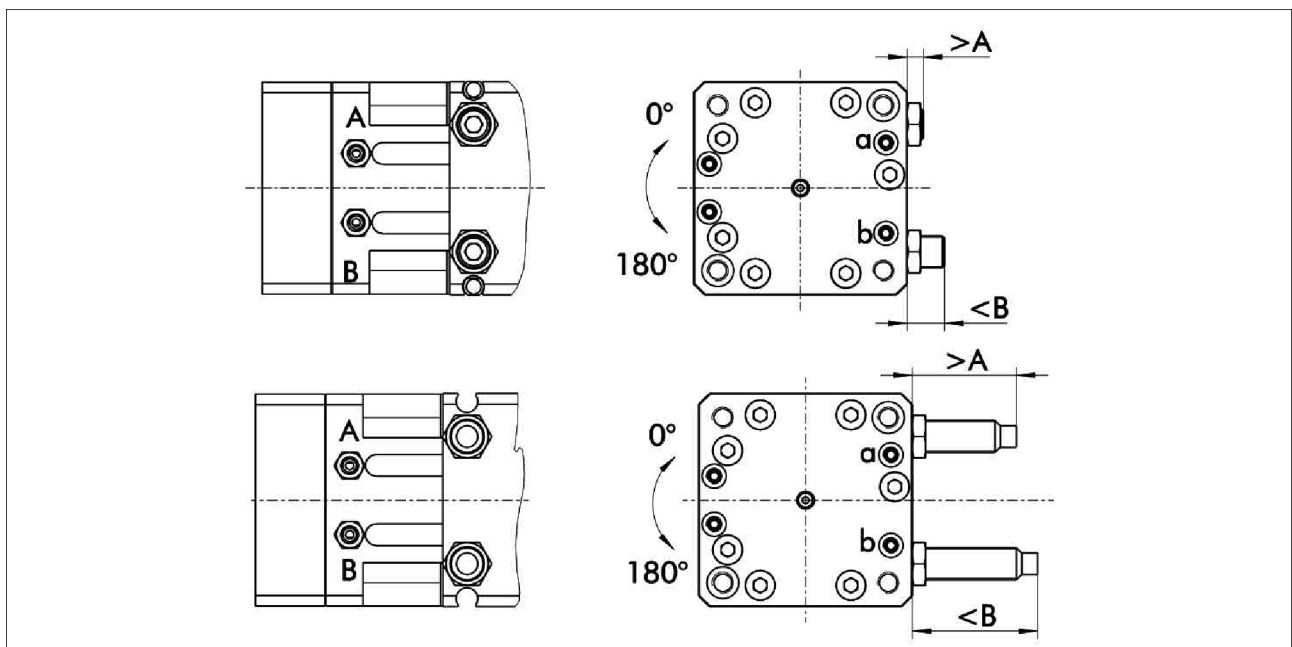

Total rotating angle range

6.2 Setting the speed

CAUTION

Material damage due to erroneous settings!

If the end position is approached too hard, the product may be damaged.

- Adjust exhaust throttle valve and shock absorber so that the movement is braked smoothly.

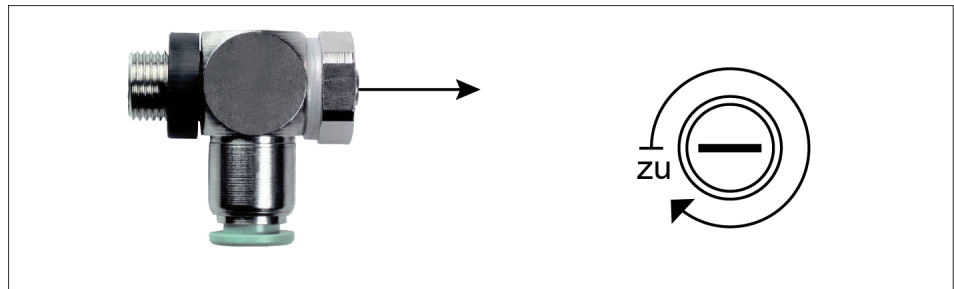

1. Close exhaust throttle valve completely.

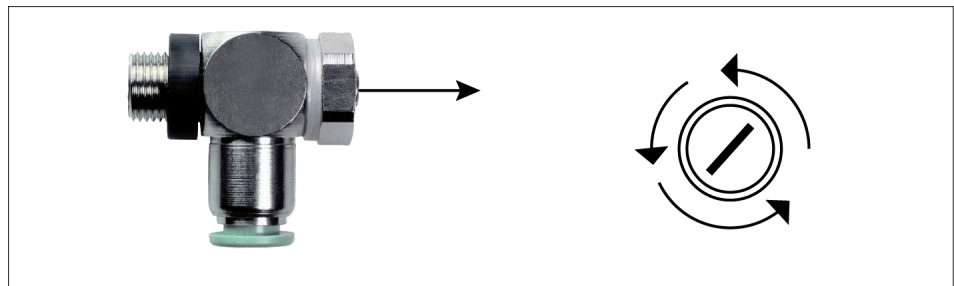

2. Open exhaust throttle valve until the product starts to move.
3. Continue to open the exhaust throttle valve incrementally until the movement decelerates smoothly.
 - ⇒ If the speed is too low, the product will brake too soon and the end position will be reached too slowly.
 - ⇒ If the speed is too high, the product will impact against the end position and the shock absorber will be overloaded.

6.3 Restart after long standstill

During a longer standstill, no compressed air may be applied to the product.

If issues occur during the restart process, see ► 7.2 [41]

7 Troubleshooting

7.1 Product does not achieve the opening and closing times

Possible cause	Corrective action
Compressed air lines are not installed optimally.	If present: Open the flow control couplings on the product to the maximum that the movement of the jaws occurs without bouncing and hitting.
	Check compressed air lines.
	Inner diameters of compressed air lines are of sufficient size in relation to compressed air consumption.
	Keep compressed air lines between the product and directional control valve as short as possible.
	Flow rate of valve is sufficiently large relative to the compressed air consumption.
	IMPORTANT! The throttle check valve must not be removed, even if the product has not reached the opening and closing times.
	If you still cannot achieve the open and close times in the latest catalog, we recommend the use of quick-air-vent-valves directly at the product.
Loading too large.	Check permissible weight and length of the gripper fingers.

7.2 Swivel movement is not executed immediately

Possible cause	Corrective action
Product was at a standstill for a long time.	<ul style="list-style-type: none"> • Vent the piston chamber. • Swivel once to end and starting positions. • Depressurize the product. • Carry out several depressurized swivel movements. • IMPORTANT! Do not spray Teflon spray or penetrating oil into the air connections! This only leads to a short-term improvement, but the grease lubrication will be washed out as a result. If the product has already been

Possible cause	Corrective action
	treated with Teflon spray or penetrating oil, it should be serviced or completely relubricated.

8 Maintenance

8.1 Notes

Original spare parts

Use only original spare parts of SCHUNK when replacing spare and wear parts.

Replacement of the housing and base jaws

The cover housing (35), fingers (3), and needle rollers (13, 14, 15) are adapted to each other. To replace these parts, send the complete module together with a repair order to SCHUNK.

CAUTION

The needle rollers are suitable only for this product and cannot be replaced with needle rollers belonging to another product of the same type and size.

8.2 Maintenance and care intervals

CAUTION

Material damage due to hardening lubricants!

Lubricants harden more quickly at temperatures above 60°C, leading to possible product damage.

- Reduce the lubricant intervals accordingly.

Size GSM-P	32 - 64
Interval [Mio. cycles]	2
Size DKM	40 / 64
Interval [Mio. cycles]	2
Size FAN	40 / 64
Interval [Mio. cycles]	2

8.3 Lubricant/greasing areas/adhesives

During maintenance, treat all greasing areas with lubricant. Apply a thin film of lubricant using a lint-free cloth or brush. SCHUNK recommends the lubricants listed.

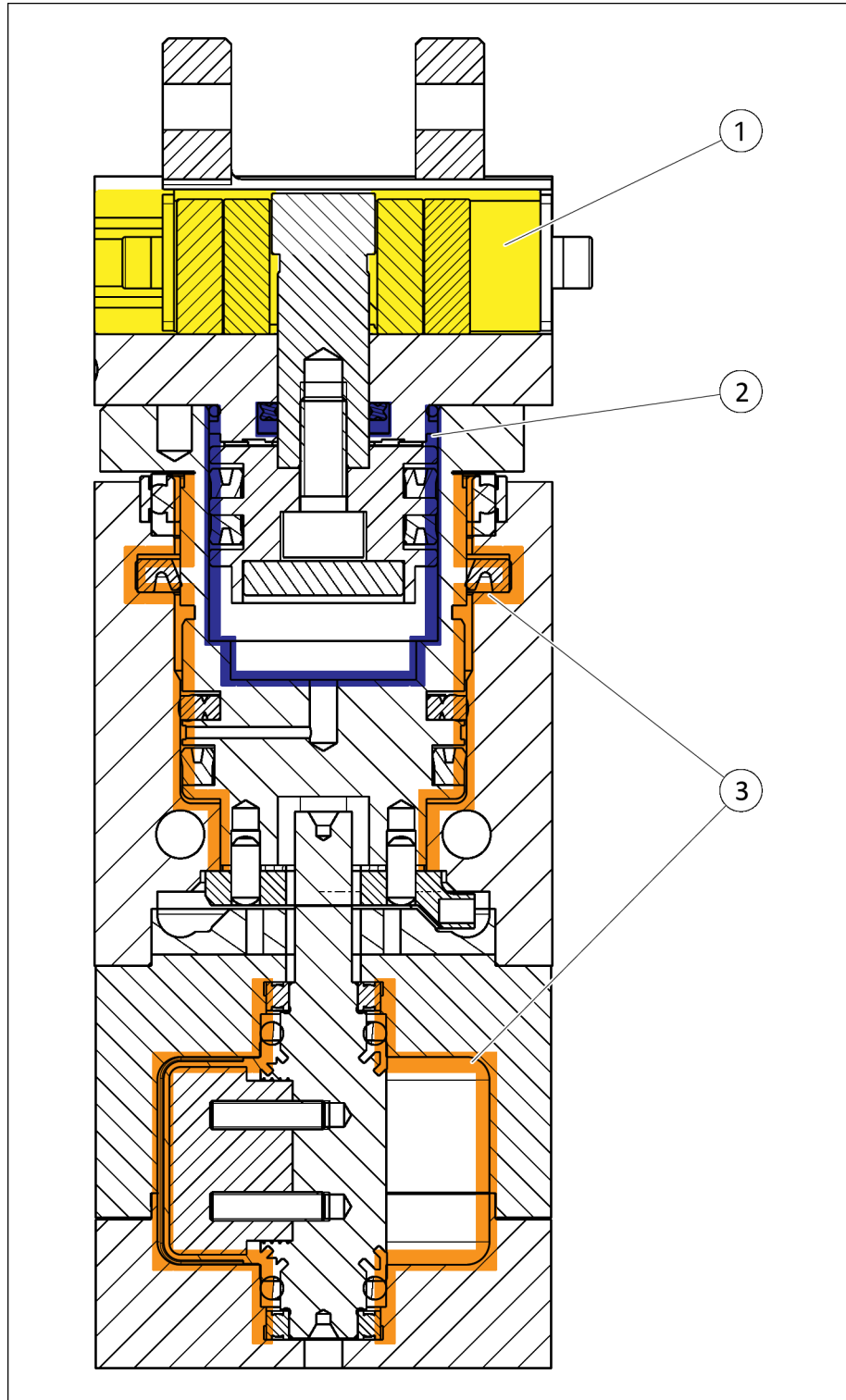

Greasing areas

Lubricant

Item	Lubricant
1	SCHUNK grease 10
2	SCHUNK grease 1 (not on surfaces that have a function on the rotary feed-through)
3	SCHUNK grease 9

Details regarding SCHUNK lubricant designations are available at [schunk.com/lubricants](https://www.schunk.com/lubricants).

The product contains food-compliant lubricants as standard.
The requirements of standard EN 1672-2:2020 are not fully met.

NOTE

- Change contaminated food-compliant lubricant.
- Observe information in the safety data sheet from the lubricant manufacturer.

Adhesives

Designation	GSM-P	DKM
Activator from Weicon for all magnets	Item 120	-
Adhesive from Weicon, 302-10 for all magnets	Item 120	Item 123
Adhesive from Weicon, 302-43 for all screws	Item 110 / 111 / 112	Item 104 / 140

Equivalent adhesives and activators from other manufacturers may be used.

8.4 Screw tightening torques

Position of the item numbers, ► 8.12 [57]

GSM-P	Item 110	Item 111	Item 112	Item 115
32	2.7 Nm	2.7 Nm	0.7 Nm	5.8 Nm
40	5.8 Nm	5.8 Nm	0.7 Nm	5.8 Nm
50	5.8 Nm	12 Nm	0.7 Nm	5.8 Nm
64	6 Nm	12 Nm	1.3 Nm	12 Nm

Tab.: Screw tightening torques GSM-P

Rotary gripping module		Item 121/124	Item 133	Item 140	Item 231	Item 232
GSM-P-32/- P-40	Basic size 40x40	1.2 Nm	-	2 Nm	6 Nm	3 Nm
GSM-P-50/- P-64	Basic size 64x64	2.0 Nm	-	4 Nm	10 Nm	6 Nm

Tab.: DKM screw tightening torques

Rotor drive	Item 101	Item 104
FAN 40		1.3 Nm
FAN 64		3.1 Nm

Tab.: Tightening torques for screws FAN

8.5 Disassembly/assembly of the unit in the basic modules

Position of the item numbers, ▶ 8.12 [📄 57]

Disassembly

1. Remove the compressed air lines.
2. Turn the gripping module (GSM) into the middle position.
3. Remove the screws (104) and pull the feed-through compact module DKM (40) off the rotor drive FAN (50).

Assembly

1. Turn the rectangular section of the rotor drive (53) with the longer side towards the center of the air connections A and B.
2. Turn the stop 1 DKM (81) with the magnet towards the 90° position, i.e. with the 090 version, one magnet has to point towards the 90° position and the other one towards the 180° position.
3. Put the feed-through compact module DKM (40) on the rotor drive FAN (50) and secure the two modules with the screws (104). Observe permissible tightening torques, ▶ 8.4 [📄 46].

8.6 Disassembly/assembly of the gripping module



⚠ WARNING

Risk of injury due to spring forces on variants with maintenance of gripping force

With the "O.D. gripping" version, the bushing (46) or cover housing (35) is under spring tension.

With the "I.D. gripping" version, the piston (36) is under spring tension.

CAUTION

The needle rollers are suitable only for this product and cannot be replaced with needle rollers belonging to another product of the same type and size.

For assembly, observe the permissible tightening torques as well as the greases and adhesives to be used, ▶ 8.4 [46] and ▶ 8.3 [44].

8.6.1 Changing the gripping module – GSM-P 32

Disassembling

1. Remove all compressed air lines.
2. Loosen and remove both screws (1).
3. Remove gripping module (2) from socket (4).
4. Remove O-ring (3) from groove of socket (4) and discard.

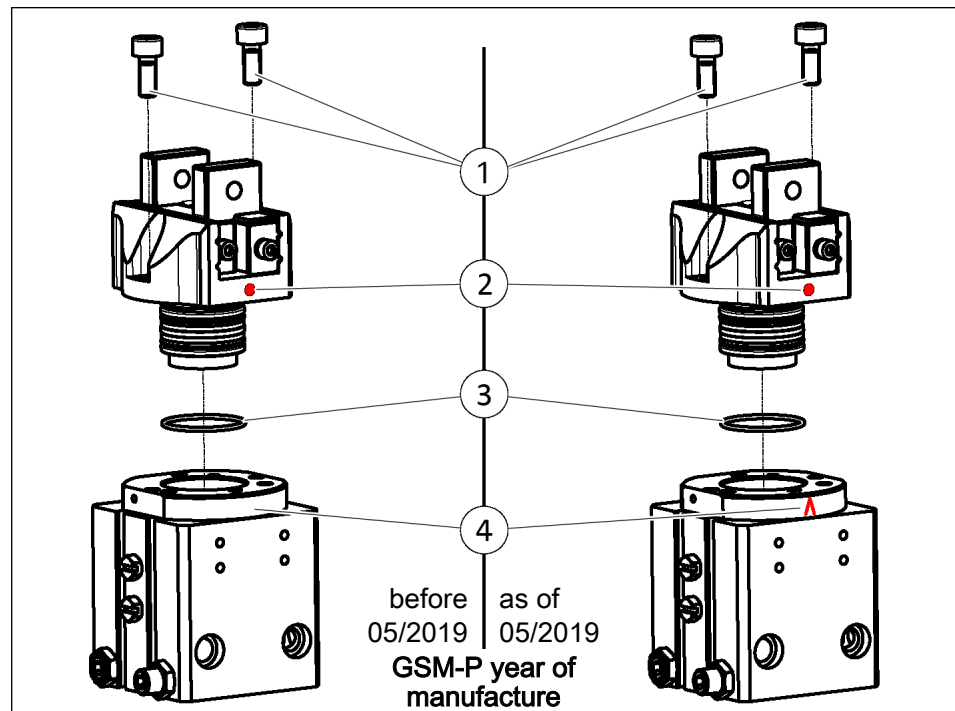

Assembling

Clean all parts thoroughly and check for damage and wear. When assembling, use the parts from the spare part package. Grease all parts using supplied brush and lubricant.

GSM-P manufactured before 05/2019:

Assembly position is not marked on the socket.

1. Insert new O-ring (3) into groove of socket (4).
2. Insert gripping module (2) into socket (4) and align so that the dot marking of the gripping module points to the middle of the semicircular side of the socket.
3. Using new screws (1) from the spare parts package, screw the gripping module (2) firmly onto the socket (4).
Note: Observe max. tightening torque!
4. Secure all compressed air lines.

GSM-P manufactured after 05/2019:

Correct assembly position is marked on the socket.

1. Insert new O-ring (3) into groove of socket (4).
2. Insert gripping module (2) into socket (4) and align so that the arrow marking of the socket points to the dot marking of the gripping module.
3. Using new screws (1) from the spare parts package, screw the gripping module (2) firmly onto the socket (4).
Note: Observe max. tightening torque!
4. Secure all compressed air lines.

8.6.2 Changing the gripping module – GSM-P 40-64

Disassembling

1. Remove all compressed air lines.
2. Loosen and remove both screws (1).
3. Remove gripping module (2) from socket (4).

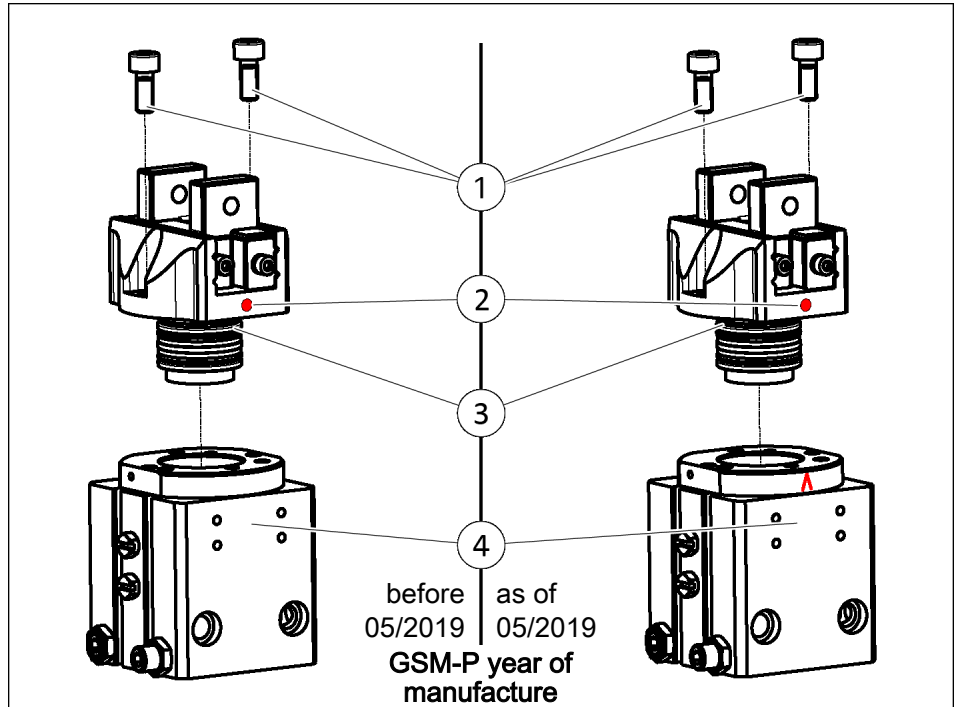

Assembling

GSM-P manufactured before 05/2019:

Assembly position is not marked on the socket.

1. Insert gripping module (2) into socket (4) and align so that the dot marking of the gripping module points to the middle of the semicircular side of the socket.
2. Using new screws (1) from the spare parts package, screw the gripping module (2) firmly onto the socket (4).
Note: Observe max. tightening torque!

3. Secure all compressed air lines.

GSM-P manufactured after 05/2019:

Correct assembly position is marked on the socket.

1. Insert gripping module (2) into socket (4) and align so that the arrow marking of the socket points to the dot marking of the gripping module.
2. Using new screws (1) from the spare parts package, screw the gripping module (2) firmly onto the socket (4).
Note: Observe max. tightening torque!

3. Secure all compressed air lines.

Clean all parts thoroughly and check for damage and wear. When assembling, use the parts from the spare part package. Grease all parts with the specified lubricant.

8.6.3 Mounting orientation of the magnets, item 120

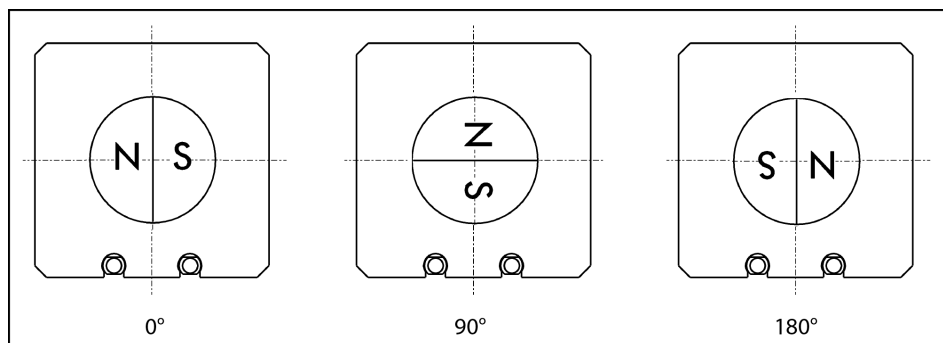

Top view in rotating angle position for 0°–180° variants

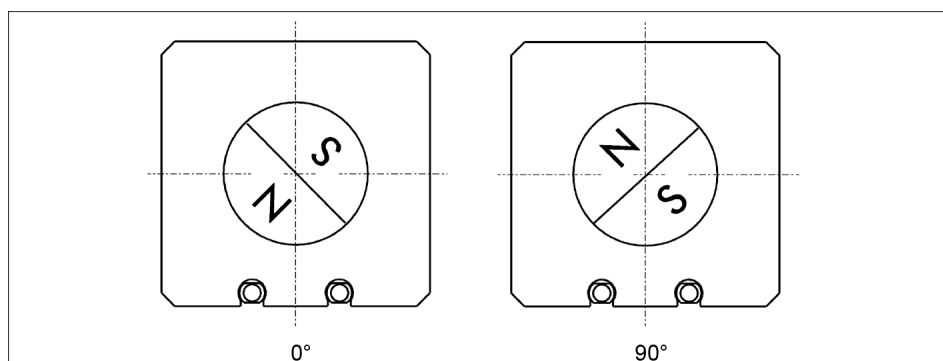

Top view in rotating angle position for 0°–90° variants

8.7 Disassembly/assembly of the DKM feed-through compact module (item 40)

Position of the item numbers, ▶ 8.12 [57]

CAUTION

If the housing (11), bearing ring (82), or bushing (44 or 46) is replaced, a new set of fitting disks (111 and 112) must be ordered.

CAUTION

The balls (142) lie loosely in the ball guide DKM GSM (85).

Disassembly

1. In order to start disassembling the DKM, the steps for disassembly/assembly of the unit into the basic modules must have been carried out, ▶ 8.5 [47].
2. Remove the O-rings (109) and ball guide rail DKM GSM (85) from the housing DKM GSM.
3. Remove the balls (142).
4. Turn the screws (140) from the bushing of the gripping module (31–34) and pull stop 1 DKM GSM (81) and the set of fitting disks (111/112) off the bushing (44 or 46).
5. Pull the gripping module (31–34) from the housing DKM GSM.

6. For elastomer variants, proceed as follows:

Remove the stops (83) after loosening the nuts (124).
Also remove the needle rollers (122).

7. For shock absorber variants, continue as follows:

Remove the shock absorber (120) after loosening the nuts (121).
Also remove the sleeves (122).

Assembly

For assembly, observe the permissible tightening torques as well as the greases and adhesives to be used, ▶ 8.4 [□ 46] and ▶ 8.3 [□ 44].

1. Grease the (11) housing DKM GSM and the bushing (44 or 46) on the running surfaces and bearings.
2. Grease the bearing ring (82).
3. Insert the bearing ring with the outer chamfer downwards into the housing DKM GSM.
4. Grease the O-rings (103) and install them in the recesses on the bushing (44 or 46).
5. Insert the gripping module into the housing DKM GSM.
6. Match up the axial bearing seat of the bushing with the fitting disks (111 or 112).
7. Place stop 1 DKM (81) onto the bushing and fasten it to the bushing using the screws (140).
8. Grease the ball guide DKM (85).
9. Turn the bushing so that stop 1 DKM (81) is pointing 180° away from the bore holes for the dampening unit.
10. Grease the needle rollers (122) and put them into the appropriate fits.
11. **For elastomer variants, proceed as follows:**
Grease the needle rollers (122) and put them into the appropriate fits.
Place one ball (142) in the housing in front of each needle roller (122) and screw the stop 2 DKM (83) into the housing.
12. **For shock absorber variants, continue as follows:**
Grease the sleeves (122) and put them on the shock absorbers (120). Insert the sleeve into the fit provided in the housing DKM GSM (11) and screw the shock absorber into the housing. Place one ball (142) in the housing in front of each sleeve (122).
13. Mount the counter nut (124) onto the stops/shock absorbers.
14. Connect the DKM module (11) to the rotor drive FAN using the screws (104). When doing this, pay attention to the assembly of the basic modules, ▶ 8.5 [□ 47].

8.8 Replacing a shock absorber for S variants

Position of the item numbers, ▶ 8.12 [📄 57]

The shock absorbers have a limited lifespan, depending on the load. For this reason, their function should be checked regularly. The shock absorber is working correctly if the unit moves gently to the end positions. When replacing it, observe the control number "-446" at the end of the shock absorber designation. These specially tested shock absorbers are only to be ordered from SCHUNK. When replacing a damper, the complete additional parts list for hydraulic dampening should be ordered.

Proceed as follows with the replacement:

1. Remove the compressed air lines.
2. Loosen the counter nut (124).
3. Remove the shock absorber (121) from the unit and remove the sleeve (122). If the latter cannot be loosened from the shock absorber, it may be helpful to use a small bar magnet or turn the unit by hand.

NOTE

If the shock absorbers are installed vertically (horizontal axis of rotation of the module), make sure that the sleeve (122) and the ball (142) are secured against falling out.

Clean all parts thoroughly and check all parts for defects and wear.

The unit is **assembled** in reverse order; finish by re-adjusting the end positions Adjusting the end positions.

8.9 Replacing an elastomer for E variants

Position of the item numbers, ▶ 8.12 [📄 57]

The elastomers have a limited lifespan, depending on the load. For this reason, their function should be checked regularly. The elastomer is working correctly if the unit moves gently to the end positions. When replacing an elastomer, the complete additional parts list for elastomer dampening should be ordered.

Proceed as follows with the replacement:

1. Remove the compressed air lines.
2. Loosen the counter nut (124).
3. Remove the shock absorber (121) from the unit and remove the sleeve (122). If the latter cannot be loosened from the shock absorber, it may be helpful to use a small bar magnet or turn the unit by hand.

NOTE

If the shock absorbers are installed vertically (horizontal axis of rotation of the module), make sure that the sleeve (122) and the ball (142) are secured against falling out.

Clean all parts thoroughly and check all parts for defects and wear.

The unit is **assembled** in reverse order; finish by re-adjusting the end positions Adjusting the end positions.

8.10 Disassembly/assembly of the FAN rotor drive (50)

Position of the item numbers, ▶ 8.12 [📄 57]

Disassembly

1. Remove the compressed air lines.
2. Loosen the screws (101) and take the upper housing (51) off the lower housing (52).
3. Remove the O-rings (109) and the centering sleeve (108).
4. Take the rotor (53) out of the housing (52) and pull the bearing (100) off the rotor.
5. Pull the O-rings (110) off the rotor.
6. Remove the stop rotor (58) and pull the stop seal (59) off the stop rotor.
7. Clean all parts thoroughly and check all parts for defects and wear.
8. renew the seals listed in the sealing kit.

Assembly

1. Lubricate the upper and lower housing (51 and 52) from the inside.
2. Grease the entire stop rotor (58).
3. Pull the stop seal (59) into the correct position on the stop rotor (58) and grease the two parts completely again.
4. Put the stop rotor in the correct position in the intended fit in the upper rotor housing (51).
5. Grease the entire rotor (53) except for the rectangular section.
6. Pull both O-rings (110) onto the rotor and lubricate them.
7. Stick the ball bearing onto the rotor.
8. Stick the rotor with the rectangular part facing down into the upper housing. Move the rotor into the 90° position, which means opposite the stop rotor (53).
9. Put the centering sleeve (108) in the upper housing (51) for assembly with the lower housing (52).
10. Lubricate four O-rings (109) and place them into the provided mirrored views in the lower housing (52).
11. Mount the upper housing with the lower housing and attach both with screws (101). The screws (101) are to be tightened "crosswise".
12. Lubricate two O-rings (109) and fit them into the upper housing (51) into the appropriate counterbores.
13. Mount the centering sleeve (108) or cylindrical pin (107) onto the upper housing (51).

8.11 Servicing and assembling the product

Maintenance

- Clean all parts thoroughly and check for damage and wear.
- Treat all greased areas with lubricant.
 - ▶ 8.3 [44]
- Oil or grease bare external steel parts.
- Replace all wear parts / seals.
 - Position of the wearing parts ▶ 8.12 [57]
 - Seal kit ▶ 1.4.1 [8]

Assembly

Assembly takes place in the opposite order to disassembly.
Observe the following:

- Unless otherwise specified, secure all screws and nuts with Loctite no. 243 and tighten with the appropriate tightening torque. ▶ 8.4 [46]

8.12 Drawings

The following figures are example images.
They serve for illustration and assignment of the spare parts.
Variations are possible depending on size and variant.

8.12.1 Assembly drawing of the basic module

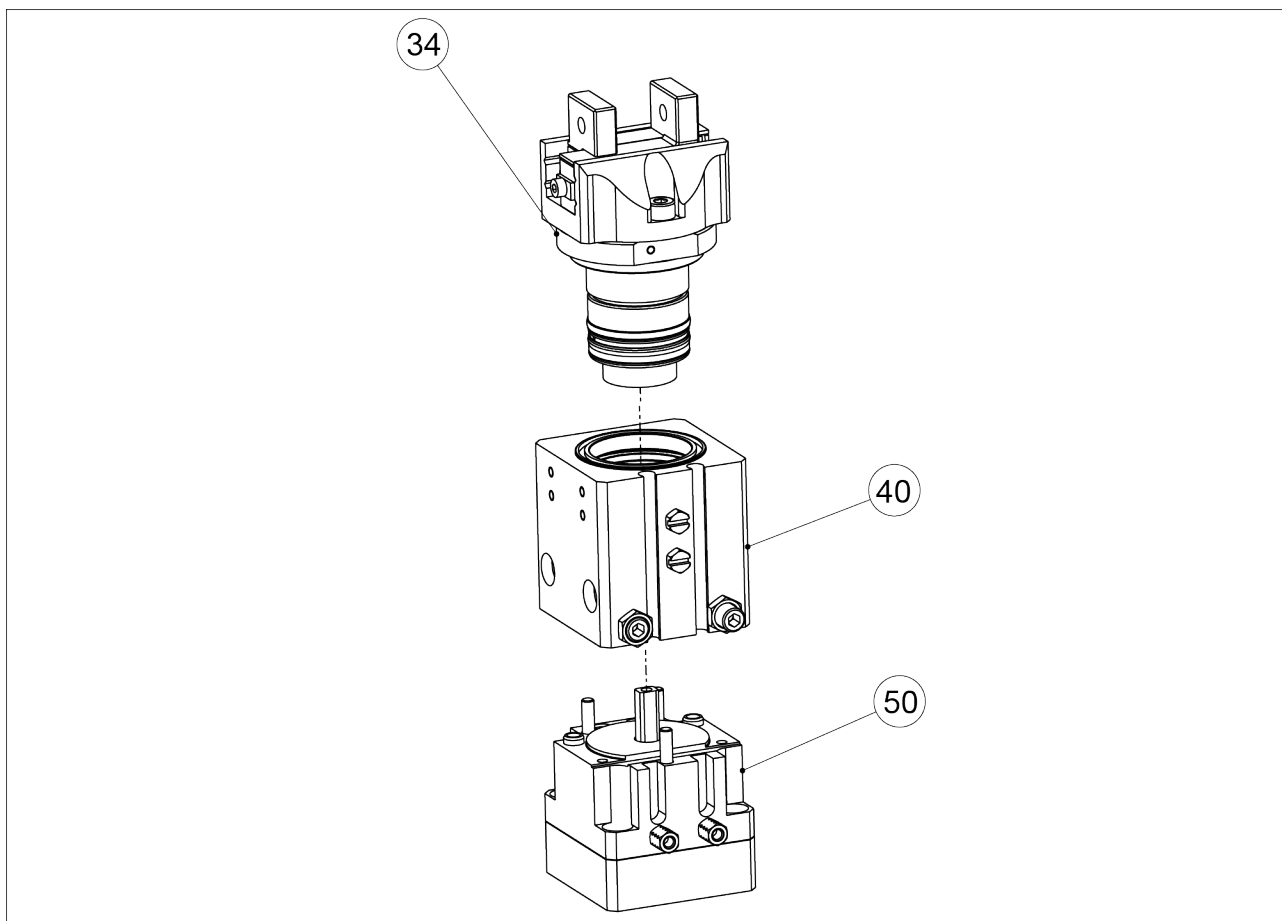

Basic module overview

34	PGM gripping module
40	DKM feed-through compact module
50	FAN rotor drive

8.12.2 Assembly drawing of the DKM and FAN modules

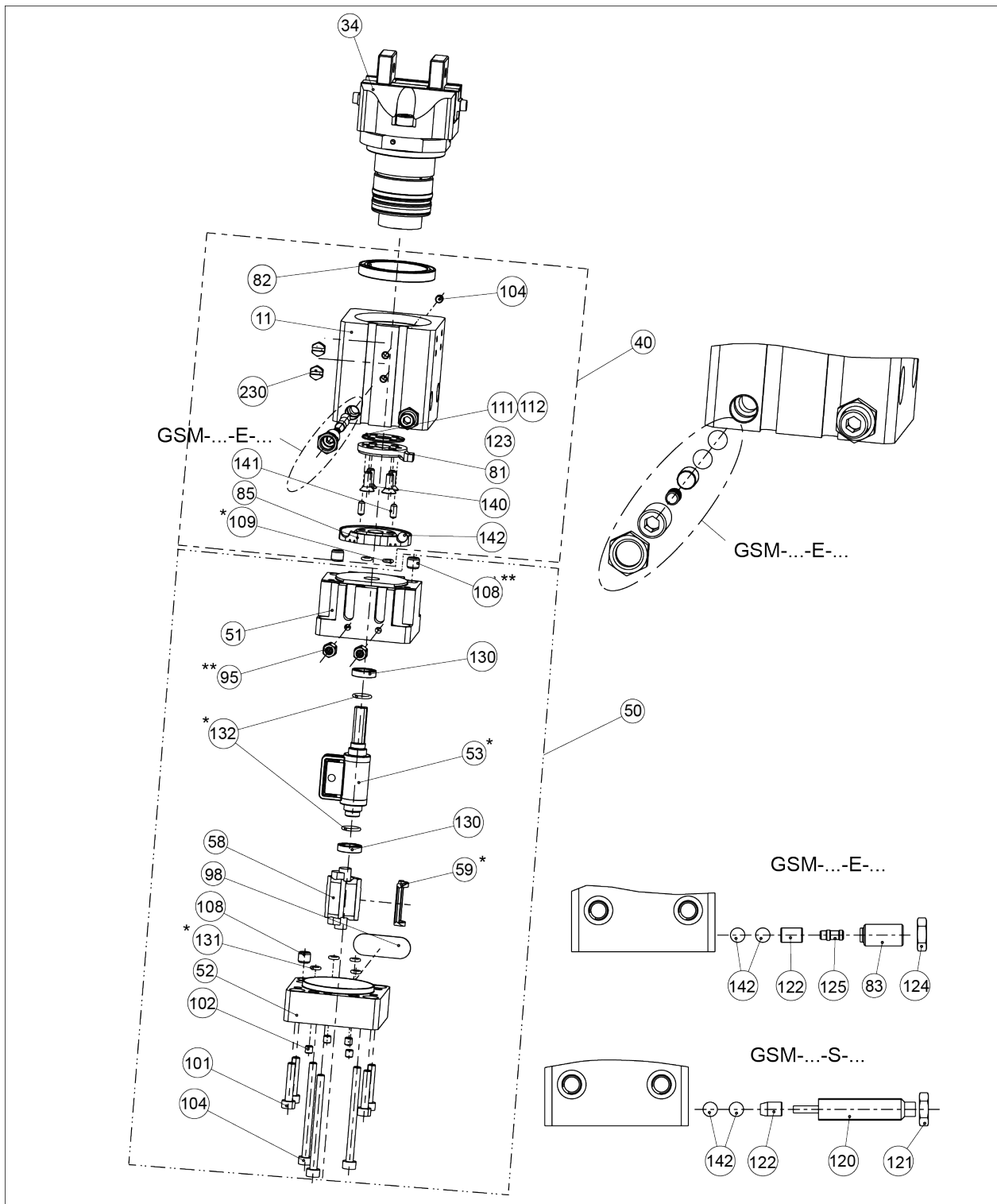

DKM and FAN overview

* Included in the seal kit. Seal kit can only be ordered completely.

** Only for the basic sizes 40 x 40 and 64 x 64

8.12.3 Assembly drawing of the gripping modules

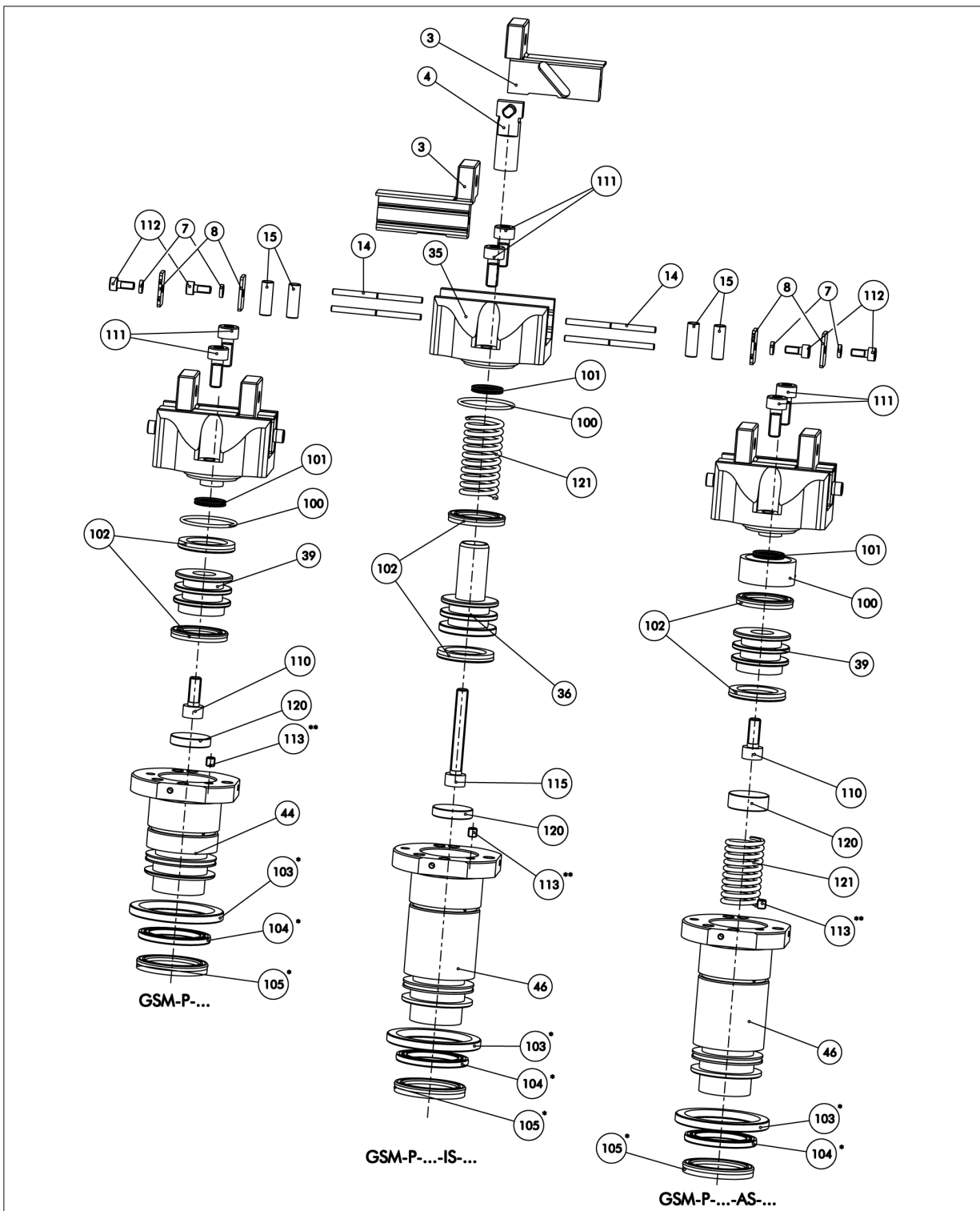

Assembly drawing of the basic modules

* Included in the parts list for the DKM feed-through compact module

** Item 113 only available for the sizes P-40, P-50, and P-64

9 Translation of the original declaration of incorporation

in terms of the Directive 2006/42/EG, Annex II, Part 1 Section B.

Manufacturer/
Distributor SCHUNK SE & Co. KG
Spanntechnik | Greiftechnik | Automatisierungstechnik
Bahnhofstr. 106 – 134
D-74348 Lauffen/Neckar

We hereby declare that the partly completed machine described below

Product designation: Rotary gripping module with parallel gripper / GSM-P /pneumatic
ID number 304630 / 304730 / 304631 / 304731 / 304632 / 304732 / 304640 /
304740 / 304641 / 304741 / 304642 / 304742 / 304650 / 304750 /
304651 / 304751 / 304652 / 304752 / 304660 / 304760 / 304661 /
304761 / 304662 / 304762 / 303830 / 303930 / 303831 / 303931 /
303832 / 303932 / 303840 / 303940 / 303841 / 303941 / 303842 /
303942 / 303850 / 303950 / 303851 / 303951 / 303852 / 303952 /
303860 / 303960 / 303861 / 303961 / 303862 / 303962

meets the following basic occupational health and safety of the Machinery Directive 2006/42/EC:

No. 1.1.1, No. 1.1.2, No. 1.1.3, No. 1.1.5, No. 1.3.2, No. 1.5.3, No. 1.5.4, No. 1.5.6, No. 1.5.8, No. 1.5.10, No. 1.5.11, No. 1.5.13

The partly completed machinery may not be put into operation until it has been confirmed that the machine into which the partly completed machinery is to be installed complies with the provisions of the Machinery Directive (2006/42/EC). The declaration shall be rendered invalid if modifications are made to the product.

Applied harmonized standards, especially:

EN ISO 12100:2010 Safety of machinery – General principles for design –
Risk assessment and risk reduction

The special technical documentation according to Annex VII, Part B, belonging to the partly completed machine, has been created.

Person authorized to compile the technical documentation:
Stefanie Walter, Address: see manufacturer's address

Signature: see original declaration

Lauffen/Neckar, March 2024

Dr.-Ing. Manuel Baumeister,
Head of Systems Engineering,
Technology & Innovation

10 UKCA declaration of incorporation

in accordance with the Supply of Machinery (Safety) Regulations 2008.

Manufacturer/ Distributor SCHUNK Intec Limited
 Clamping and gripping technology
 3 Drakes Mews, Crownhill
 MK8 0ER Milton Keynes

We hereby declare that on the date of the declaration the following partly completed machine complied with all basic safety and health regulations found in the "Supply of Machinery (Safety) Regulations 2008".

The declaration shall be rendered invalid if modifications are made to the product.

Product designation: Rotary gripping module with parallel gripper / GSM-P / pneumatic
 ID number 304630 / 304730 / 304631 / 304731 / 304632 / 304732 / 304640 /
 304740 / 304641 / 304741 / 304642 / 304742 / 304650 / 304750 /
 304651 / 304751 / 304652 / 304752 / 304660 / 304760 / 304661 /
 304761 / 304662 / 304762 / 303830 / 303930 / 303831 / 303931 /
 303832 / 303932 / 303840 / 303940 / 303841 / 303941 / 303842 /
 303942 / 303850 / 303950 / 303851 / 303951 / 303852 / 303952 /
 303860 / 303960 / 303861 / 303961 / 303862 / 303962

The partly completed machine may not be put into operation until it has been confirmed that the machine into which the partly completed machine is to be installed complies with the provisions of the "Supply of Machinery (Safety) Regulations 2008".

Applied harmonized standards, especially:

EN ISO 12100:2010 Safety of machinery – General principles for design –
 Risk assessment and risk reduction

The special technical documentation according to Annex VII, Part B, belonging to the partly completed machine, has been created.

Person authorized to compile the technical documentation:
 Marcel Machado, address: refer to manufacturer's address



Lauffen/Neckar, March 2024

Dr.-Ing. Manuel Baumeister,
 Head of Systems Engineering,
 Technology & Innovation

11 Information on the RoHS Directive, REACH Regulation and Substances of Very High Concern (SVHC)

RoHS Directive

SCHUNK products are classified as "large-scale stationary installations" or as "large-scale stationary industrial tools" within the meaning of Directive 2011/65/EU and its extension 2015/863/EU "on the restriction of the use of certain hazardous substances in electrical and electronic equipment (RoHS)", or fulfill their intended function only as part of one. Therefore products from SCHUNK do not fall within the scope of the directive at this time.

REACH Regulation

Products from SCHUNK fully comply with the regulations of Regulation (EC) No. 1907/2006 "concerning the Registration, Evaluation, Authorization and Restriction of Chemicals (REACH)" and its amendment 2022/477. SCHUNK attaches great importance to completely avoiding chemicals of concern to humans and the environment wherever possible.

Only in rare exceptional cases do SCHUNK products contain SVHC substances on the candidate list with a mass content above 0.1%. In accordance with Article. 33 (1) of Regulation (EC) No. 1907/2006, SCHUNK complies with its duty to "communicate information on substances in articles" and lists the components concerned and the substances used in an overview that can be viewed at [schunk.com/SVHC](https://www.schunk.com/SVHC).

Signature: see original declaration

Lauffen/Neckar, March 2024

Dr.-Ing. Manuel Baumeister,
Head of Systems Engineering,
Technology & Innovation

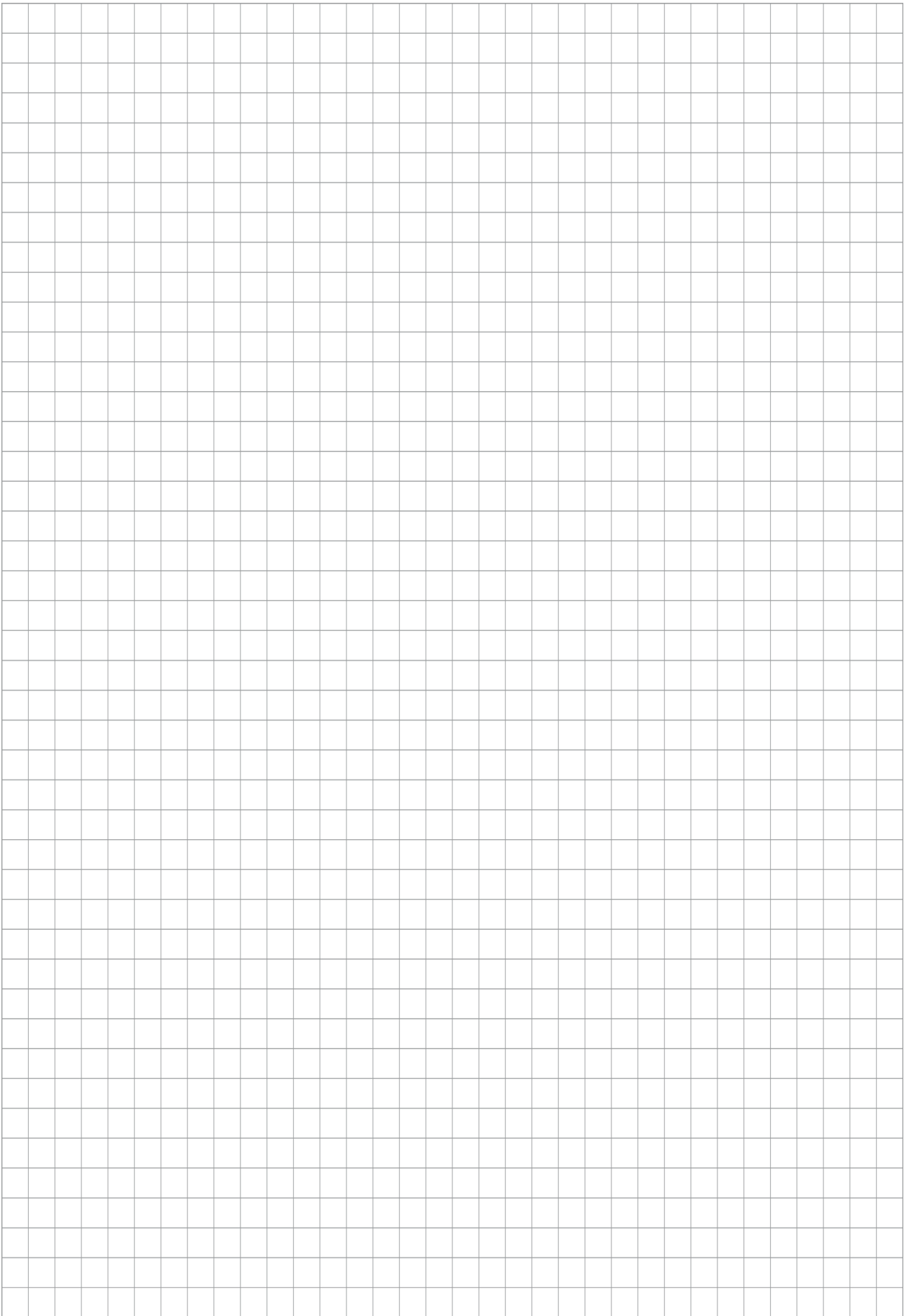



SCHUNK SE & Co. KG
Spanntechnik | Greiftechnik | Automatisierungstechnik

Bahnhofstr. 106 - 134
D-74348 Lauffen/Neckar
Tel. +49-7133-103-0
info@de.schunk.com
schunk.com

Folgen Sie uns | *Follow us*



Wir drucken nachhaltig | *We print sustainable*