

Kitronik Ltd – How to calculate capacitors in series and parallel

Capacitors in parallel

When capacitors are connected across each other (side by side) this is called a parallel connection. This is shown below.

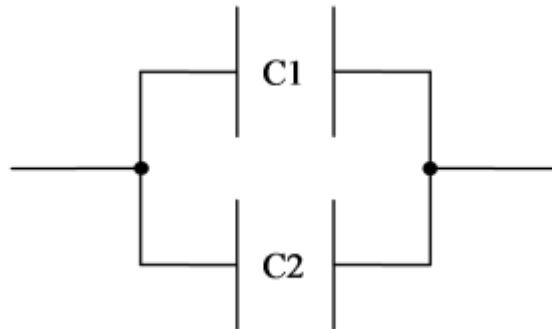

To calculate the total overall capacitance of a number of capacitors connected in this way you add up the individual capacitances using the following formula:

$$C_{total} = C1 + C2 + C3 \text{ and so on}$$

Example: To calculate the total capacitance for these three capacitors in parallel

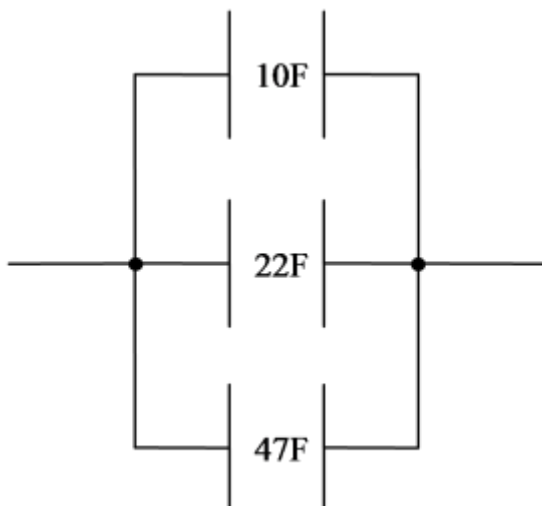

$$\begin{aligned} C_{total} &= C1 + C2 + C3 \\ &= 10 \text{ F} + 22 \text{ F} + 47 \text{ F} \\ &= 79 \text{ F} \end{aligned}$$

Task 1: Calculate the total capacitance of the following capacitors in parallel

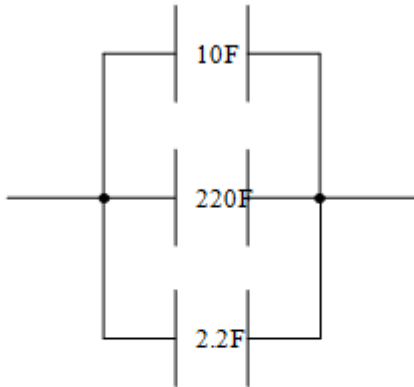

$$C_{total} = \dots\dots\dots$$

$$= \dots\dots\dots$$

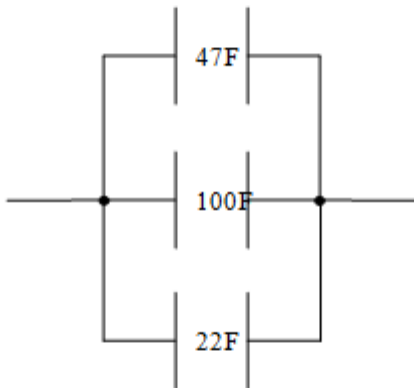

$$C_{total} = \dots\dots\dots$$

$$= \dots\dots\dots$$

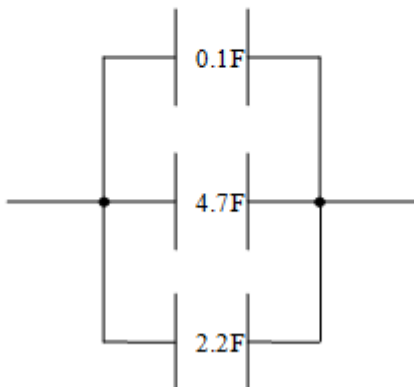

$$C_{total} = \dots\dots\dots$$

$$= \dots\dots\dots$$

Capacitors in series

When capacitors are connected one after each other this is called connecting in series. This is shown below.

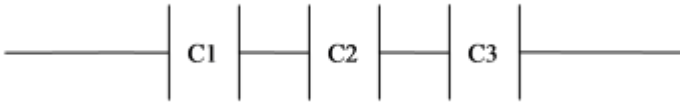

Two capacitors in series

To calculate the total overall capacitance of two capacitors connected in this way you can use the following formula:

$$C_{total} = \frac{C1 \times C2}{C1 + C2}$$

Example: To calculate the total capacitance for these two capacitors in series

$$C_{total} = \frac{C1 \times C2}{C1 + C2} = \frac{10F \times 22F}{10F + 22F} = \frac{220F}{32F} = 6.87F$$

Task 2: Calculate the total capacitance of the following capacitors in series

$$C_{total} = \frac{\dots \times \dots}{\dots + \dots} = \frac{\dots}{\dots} = \dots$$

$$C_{total} = \frac{\dots \times \dots}{\dots + \dots} = \frac{\dots}{\dots} = \dots$$

$$C_{total} = \frac{\dots \times \dots}{\dots + \dots} = \frac{\dots}{\dots} = \dots$$

Three or more capacitors in series

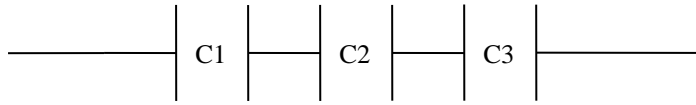

To calculate the total overall capacitance of three or more capacitors connected in this way you can use the following formula:

$$\frac{1}{C_{total}} = \frac{1}{C_1} + \frac{1}{C_2} + \frac{1}{C_3} + \text{and so on}$$

Example: To calculate the total capacitance for these three capacitors in series

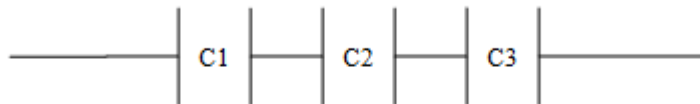

$$\frac{1}{C_{total}} = \frac{1}{10F} + \frac{1}{10F} + \frac{1}{33F} = 0.1F + 0.1F + 0.03F = \mathbf{0.23F}$$

$$C_{total} = \frac{1}{0.23F} = \mathbf{4.35F}$$

Task 3: Calculate the total capacitance of the following capacitors in series

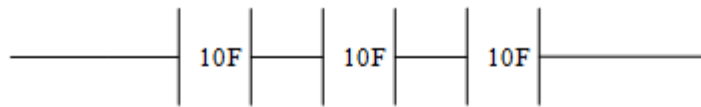

$$\frac{1}{C_{total}} = \frac{1}{\dots\dots\dots} + \frac{1}{\dots\dots\dots} + \frac{1}{\dots\dots\dots} = \dots\dots\dots + \dots\dots\dots + \dots\dots\dots = \dots\dots\dots$$

$$C_{total} = \frac{1}{\dots\dots\dots} = \dots\dots\dots$$

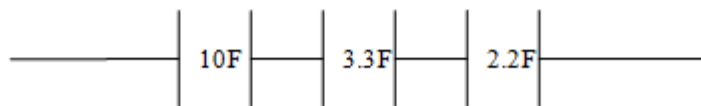

$$\frac{1}{C_{total}} = \frac{1}{\dots\dots\dots} + \frac{1}{\dots\dots\dots} + \frac{1}{\dots\dots\dots} = \dots\dots\dots + \dots\dots\dots + \dots\dots\dots = \dots\dots\dots$$

$$C_{total} = \frac{1}{\dots\dots\dots} = \dots\dots\dots$$

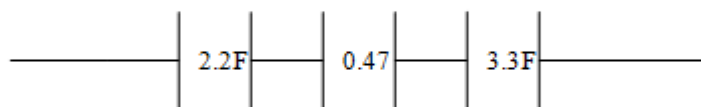

$$\frac{1}{C_{total}} = \frac{1}{\dots\dots\dots} + \frac{1}{\dots\dots\dots} + \frac{1}{\dots\dots\dots} = \dots\dots\dots + \dots\dots\dots + \dots\dots\dots = \dots\dots\dots$$

$$C_{total} = \frac{1}{\dots\dots\dots} = \dots\dots\dots$$

Answers

Task 1

1 = 232.2F

2 = 169.0F

3 = 7.0F

Task 2

1 = 2.48F

2 = 14.99F

3 = 4.11F

Task 3

1 = 3.33F

2 = 1.67F

3 = 0.35F

Note

The capacitor values in this worksheet have been kept high (close to or greater than one). This is to simplify the learning experience. In reality typical capacitor values are much smaller than one.