

Product Design

Case studies in applications of plastics and rubbers

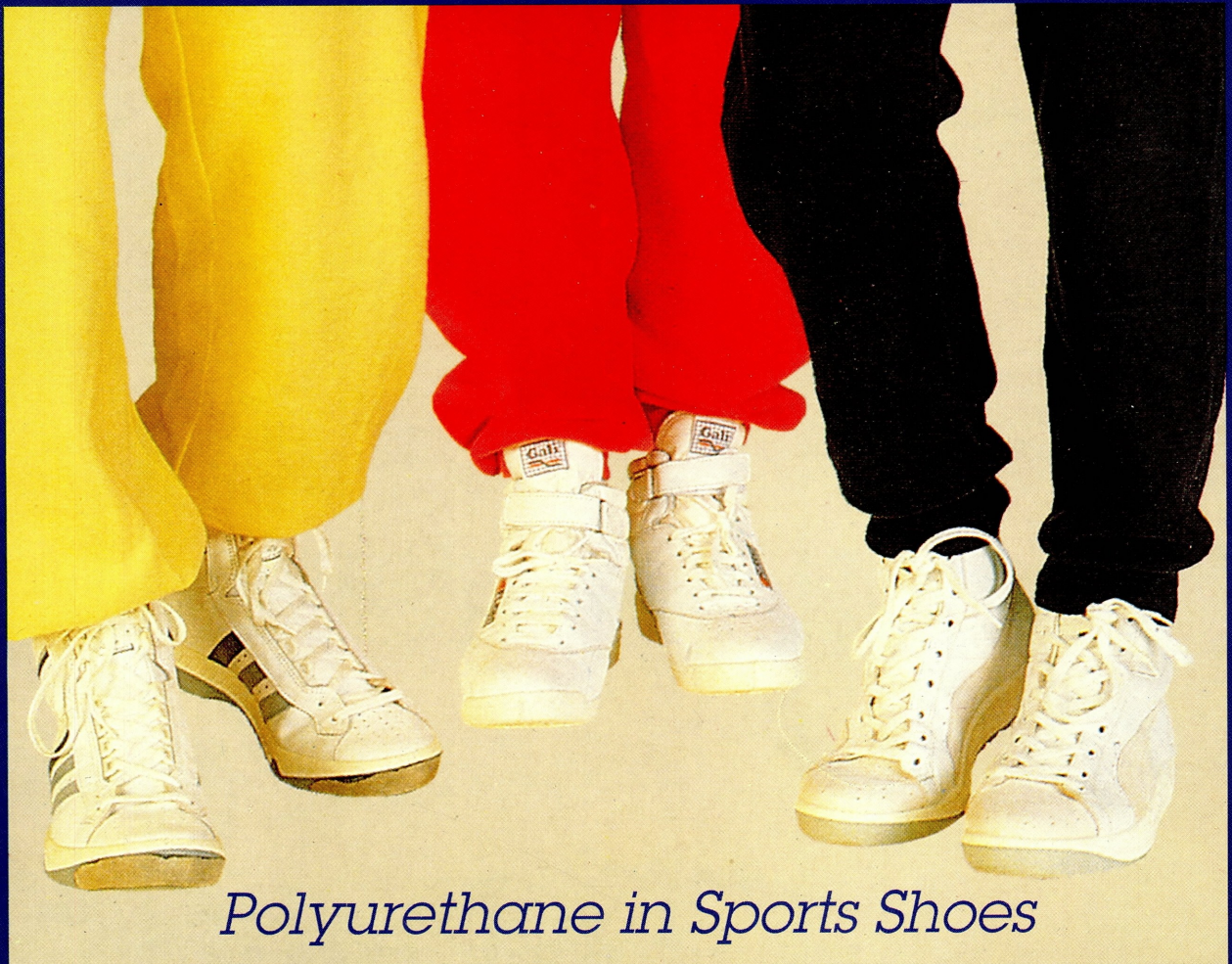

Polyurethane in Sports Shoes



PRODUCT DESIGN

Case studies in applications of
plastics and rubbers

POLYURETHANE IN SPORTS SHOES

Acknowledgments

This document was produced in collaboration with ICI Polyurethanes who assisted with the technical details and provided funding for development and printing.



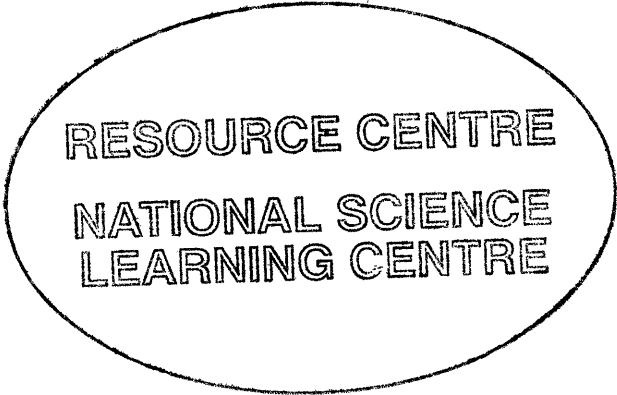

RESOURCE CENTRE
NATIONAL SCIENCE
LEARNING CENTRE

Contributor

Peter Galloway - on behalf of ICI Polyurethanes

Editor

Alan Stancliffe

Polymer Industry Education Centre
Department of Chemistry
University of York
Heslington
York
YO1 5DD

Telephone (0904) 432524

© Jointly held by ICI and the University of York

Published 1994
ISBN: 1 85342 703 9

The copyright holders waive the copyright on the material which follows to the extent that teachers may reproduce this material for use with their pupils in the establishment for which the material was purchased, but for all other purposes permission to reproduce any of this material in any form must be obtained from ICI or the University of York. The material may not be duplicated for lending, hire or sale.

CONTENTS

	Page
Foreword	iv
Introduction	
<i>Materials Selection in Product Design</i>	1
<i>Development of a New Product</i>	1
<i>Development of a New Sports Shoe Design</i>	2
<i>Soles and Uppers</i>	2
<i>Factors Influencing the Development of a New Product</i>	2
<i>Activity 1</i>	3
Analysis of General Functional Requirements for Shoe Soles	3
Materials used in Shoe Soles	3
The case for polyurethane	4
<i>Activity 2</i>	4
The Manufacture of 'Trainers'	
<i>Using polyurethane</i>	4
<i>Teacher Demonstration - Making a sample of blown polyurethane foam</i>	6
<i>Autoadhesive</i>	6
<i>General Manufacturing Process</i>	7
The construction of sports shoe soles	7
<i>Heel-strike</i>	8
<i>Activity 3</i>	8
<i>Activity 4</i>	8
Supplementary Activities	
<i>Activity S1 - Abrasion - investigative exercise</i>	10
<i>Activity S2 - Slip Resistance - investigative exercise</i>	11
Appendix 1 - Comparison of elastomeric materials properties	14
Appendix 2 - Other Applications of 'Blown' Polyurethane	15
Appendix 3 - Materials Supplies	16
Appendix 4 - List of student sheets	17
Appendix 5 - Some suggestions for <i>Activity 3</i>	18
Appendix 6 - Possible Solutions to <i>Activity 4</i>	19
OHP1	a) Factors influencing the development of a new product b) New Product Path
OHP2	a) Schematic diagram of industrial production b) Making a small sample of polyurethane

Foreword

This package has been produced as a result of requests from teachers of Design and Technology. They asked for case study resources which demonstrate the processes involved in industrial product design and selection of materials for manufacture. It consists of a teachers booklet and separate student work sheets.

The package is intended to provide background information for use by teachers and students involved with Key Stage 4 Design and Technology courses (GCSE) which contain elements of product design. It could also be used for Key Stage 3 and post sixteen (A level, GNVQ) students by modifying the level of expected outcomes in the suggested activities.

The teachers booklet deals with the different stages of market research and product design in the sports shoe industry, the selection of appropriate materials and manufacturing processes.

Separate student copy master sheets are provided which contain background information and suggestions for analysis, investigative and problem solving activities. The information provided in these sheets is also appropriate for product analysis exercises which can be devised by the teacher to suit their own circumstances. Rules for photocopying material are given at the bottom of page ii.

The supplementary investigations contained in the teachers booklet make use of equipment which can be easily assembled from materials commonly available in science and technology departments. These supplementary activities can be used to support the work being carried out from the student sheets as teachers see fit.

Polyurethane Case Study

Teachers Notes

Introduction

Materials Selection in Product Design

When designers are considering which materials to select for a particular product they normally liaise with materials experts who then advise on the development process. There are two fundamental concepts which are considered in the selection of materials. These are:

- Materials must have properties which allow the designer to produce a required effect.
- The choice of material will influence the manufacturing methods and vice-versa.

Designers are not normally experts in, but are familiar with materials and manufacturing processes. Most designers build up a number of personal contacts with specialists in materials science, manufacturers of processing equipment and mould makers and draw on their experience while seeking solutions to problems.

There have been considerable developments in new materials over the past few years which have found applications in almost every field of design and manufacture. This has made the process of material selection more complex for designers. When selecting materials for specific products the designer must consider which one offers the best balance of properties. It is unlikely that any material will meet the specifications perfectly and the usual compromises are between desired performance and cost. Some of the main factors to be taken into account are listed in student sheet 1 and a class discussion on materials selection could be centred around this.

Development of a New Product

Analytical studies of industrial management and business performance structures have identified three kinds of cycle times. These are time-to-market (i.e. design and development or lead time), production time, and delivery time (order processing). The first stage is the design and development cycle (or lead time). In the shoe industry this usually takes about six months. A diagram (New Product Path) is given in student sheet 2 which illustrates the various stages in this process. Student sheet 2 and the following notes can be used together to form the basis of a class discussion of the design cycle involved in the development of a new sports shoe product.

Development of a New Sports Shoe Design

Typical working stages in the development of a new sports shoe design are:

- a) Develop a marketing strategy - identify the customers who will buy the shoes.
- identify the type of image the product range will project.
- b) Designer is briefed and produces several concept proposals for consideration by the project managers.
- c) Designer develops the proposals approved by the project managers.
- d) Designer commissions the last shapes from the manufacturer. (The last is the model used for shaping the upper part of a shoe).
- e) When lasts are ready the designer produces outlines of the upper shape on the last using Computer Aided Design (CAD) to visualise the shoe in three dimensional coloured images.
- f) A prototype sole-mould is commissioned, and development of the product is transferred to the project engineer.
- g) Project engineer liaises with the designer, toolmaker and manufacturer to produce prototypes.
- h) Prototypes are tested for fit and quality and assessed for consumer acceptability.
- i) Any necessary modifications are made.
- j) Lasts are produced for a range of sizes and fittings as required by the marketing brief.
- k) Several designs of upper will be used with each last and sole shape.
- l) Bulk tooling is commissioned in preparation for final production.

The aspects which influence a new shoe design can also be grouped into factors **leading** to production and factors **controlling** production. A diagram (Factors Related to Production) is given in **student sheet 2** to show this. Commercial research has identified production time as being the key to profitability. The research has shown that companies who have managed to reduce production cycle time by 50% have improved their return on investment by about 10%.

Soles and Uppers

Soles must be highly flexible and the designer must be careful to avoid tread patterns which would cause a build up of uneven stresses and strains, e.g. local stress, when the shoe is flexed. It is common for designers to use computerised finite element analysis packages (as used with engineering applications) to investigate the effect of sole pattern on distortion stresses. **Student sheet 3** can be used as the basis for a class discussion of this.

Short term changes to soles and lasts are not feasible. Manufacturers need to anticipate large volume production from their investment. However, once the tooling has been set up it is possible to develop related but different upper designs for bulk production in less than three weeks. Discuss this aspect using **student sheet 3**.

Factors Influencing the Development of a New Product

The development of a new product range in the sports shoe industry is influenced by many factors, shown in the following diagram. These should be used in the class discussion outlined in **Activity 1**, on **student sheet 4**.

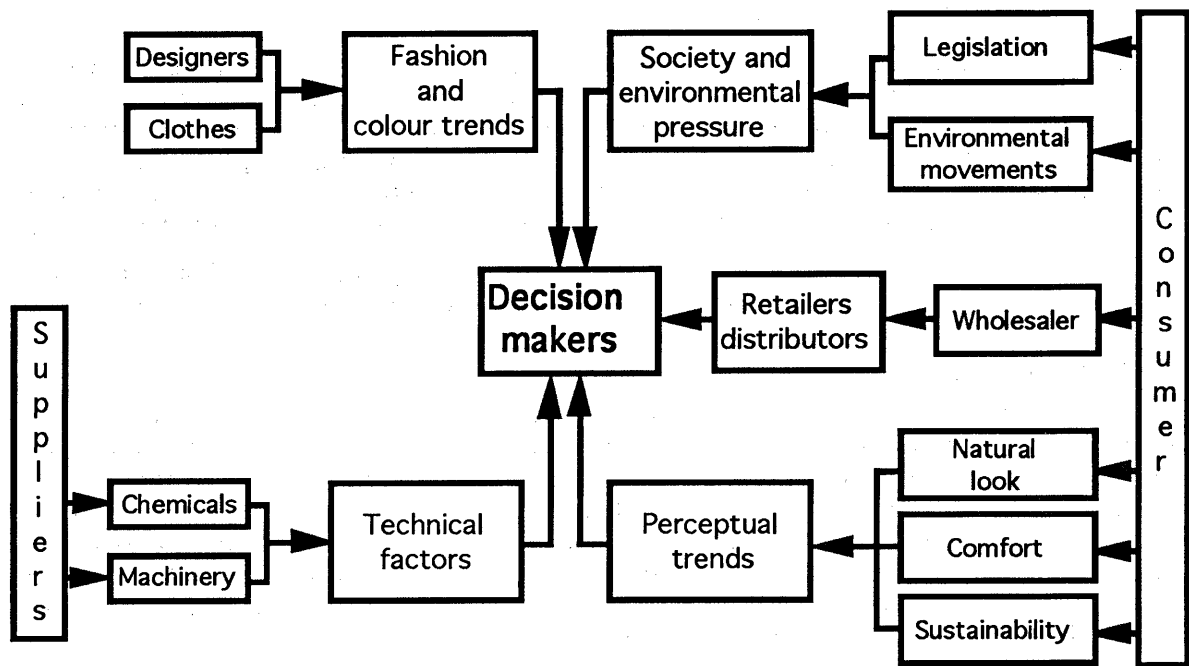

Factors influencing the development of a new product

Activity 1

This is an exercise based on the market research stage of the design and development cycle. OHP1 can be used in a class discussion to help students formulate a structure for their investigations. This activity could be carried out with students working in small groups and might include the following:

- A survey of existing stock kept by local retail outlets to determine current popular fashion and colour trends
- A survey to compare current costs to the customer
- A survey of preferences within the school population
- Development of a marketing strategy from the information obtained

Analysis of General Functional Requirements for Shoe Soles

Unless you are a bare foot athlete, walking, running, jumping, climbing all involve trapping a shoe sole between your foot and the ground. There are many properties of the material from which the sole is made that affect the efficiency and the comfort of the activity. Other properties affect the number of steps you can take before the soles wear out. It is interesting that it used to be necessary to make shoes so that the soles were easy to repair because the uppers lasted much longer than the soles. With modern materials, however, although the uppers still last as long as they used to do, the soles may last even longer and there is no need to consider their repair. A list appears in student sheet 5 which demonstrates the different properties needed for shoe soles. This can be discussed and is used in Activity 2.

Materials Used in Shoe Soles

Student sheet 6 contains a table which shows historically how the materials used in shoe soles have changed and this could form the basis of a class discussion.

The Case for Polyurethane

Designers now use a range of plastics for all components in shoe design. The main input of polyurethane has been as a soling material. One reason for this is its durability which exceeds that of all other footwear product related materials with the exception of high quality rubber. The cushioning property of polyurethane has become more important of late. Initially this was incorporated in sports shoes but has now become a sought after property in everyday shoes.

Student sheet 7 contains a list of properties of polyurethane which relate to its general use for shoe soles. This can be discussed and is used in Activity 2.

Activity 2

This is a functional analysis investigative exercise designed to illustrate the considerations which are involved with materials selection. It can be done with students working individually or in small groups. Students are required to identify the functional requirements which specifically apply to sports shoes from the general list given in student sheet 5. They must then compare these requirements with the list of polyurethane properties given in student sheet 7 in order to produce a short written report on the suitability of the material for use in the design and manufacture of sport shoe soles.

Market research has shown that many customers still prefer the look and feel of natural rubber and leather. Having achieved superior performance qualities, much of the development in polyurethane is now aimed at producing a more attractive look and feel to the soles of shoes.

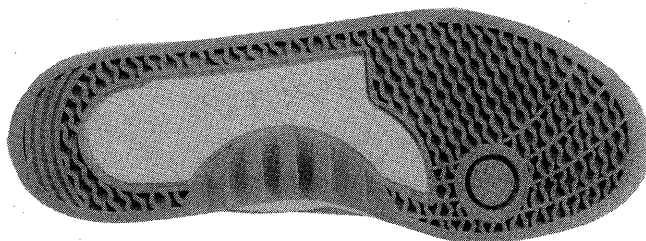

Typical sports shoe sole pattern

NOTE : Polyurethanes are also resistant to a wide range of industrial and agricultural chemicals. Ask students in which sports/athletic events they think this would be an additional consideration, where the competitors wear trainers? (e.g. cross-country runners may come into contact with agricultural chemicals or marathons where there may be oil, petrol and other deposits on road surfaces.)

The Manufacture of 'Trainers'

Using polyurethane

Polyurethanes are plastics. Whereas most other materials exist prior to manufacturing processes (cutting, shaping, moulding, etc.) polyurethane is almost always created in the form of the product which has been designed (i.e. it does not normally exist separately as a material). There are many different polyurethanes. The solid plastic can be as rubbery as a rubber band or as hard as the case of a computer (or somewhere in between).

Polyurethanes can also be made as foams so that, instead of needing 1200 kg to fill a cubic metre of space (if the polyurethane is solid), as little as 25 kg can fill the same space.

To manufacture a polyurethane shoe sole two chemicals, a mixing machine and a mould for the sole are needed. The chemicals are a polyisocyanate and a polyol - there are several different polyisocyanates and very many polyols. The chemical reaction between any polyisocyanate and any polyol creates a polyurethane. Usually the chemicals are liquid but the polyurethane they produce is a solid.

So the feature that all polyurethanes have in common is the chemical reaction that creates them. The feature that makes one polyurethane different from another is the particular polyisocyanate and/or the particular polyol used to produce that reaction. A polyurethane chemist can predict the properties of the resulting material from the initial polyisocyanate and polyol used.

The two liquid raw materials are very viscous, more like treacle than like water, but their viscosity is reduced by warming them a few degrees prior to mixing. Amounts of each raw material are accurately measured to produce a particular polyurethane mix. If the liquid mixture is poured or injected into a mould it will take on the form of the mould and solidify to produce that particular product, for example a shoe sole mould. The reaction produces heat (an exothermic reaction) so the polyurethane becomes warmer in the first stage of the reaction and is therefore less viscous. The pouring is done within the first 10 seconds whilst the mixture is in its least viscous state.

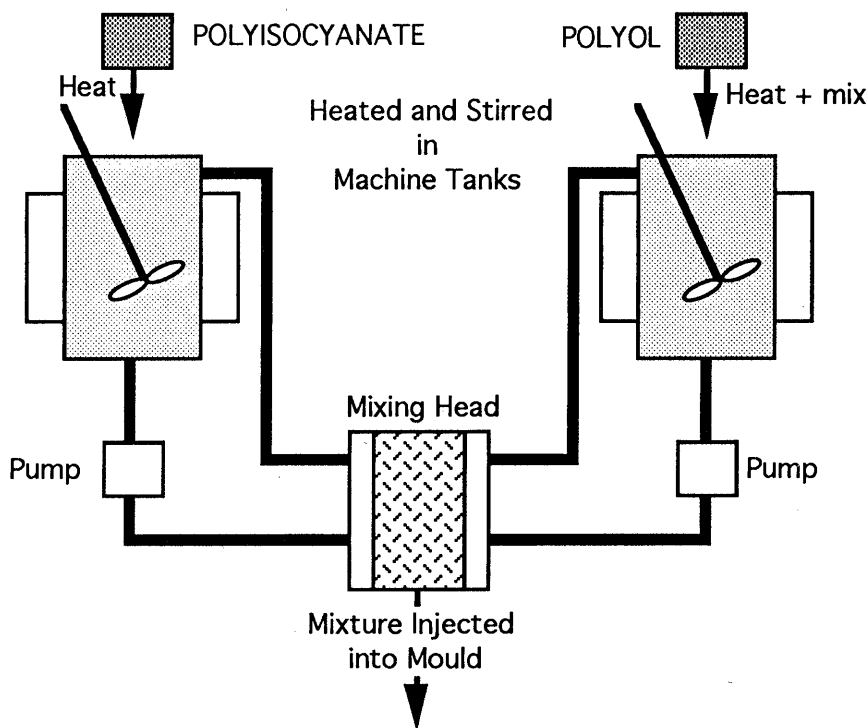

Schematic diagram of industrial production

The liquid mix can also be sprayed onto a surface where it will adhere as a coating, or poured into cavities to fill them and bond various components together.

If the polyurethane is to be foamed rather than solid it is necessary to create lots of gas bubbles inside the liquid before it becomes solid. One way of doing this is by including some water in the polyol - it will react with some of the

polyisocyanate to create carbon dioxide. (This reaction will also create another solid material rather different from the polyurethane but mixed with it, so that the properties of the solid phase of the end-product are slightly changed). Or a blowing agent - usually a liquid with a low boiling point (say about 25 to 30 °C) - is mixed in with the polyol.

The heat of the reaction converts the blowing agent into vapour. The tiny bubbles initially produced grow bigger as the vapour becomes warmer. When the mixture becomes solid the bubbles are trapped, creating a cellular structure. Such blowing agents can be chosen so that, unlike water, they do not interfere with the fundamental polyurethane-forming reaction. Polyurethane can be blown to 30 or 40 times the original volume of the mix. The demonstration outlined below could be carried out by the teacher and needs no specialist apparatus. It can be done in conjunction with OHP2 and a class discussion comparing the demonstration with industrial production of polyurethane.

Teacher Demonstration

To produce a small sample of foamed polyurethane in the lab/workshop:

1. Prepare accurate quantities of each liquid raw material (see appendix 3).
2. Mix the two liquids together in a disposable waxed paper cup or beaker (industrial manufacturing processes use a more accurate and more efficient piece of special equipment for this).
3. Soon after they are mixed - usually less than one minute - the chemical reaction will be complete, producing a piece of solid polyurethane.

Care Avoid touching the material at this stage since the reaction is exothermic and both the container and polyurethane will be hot.

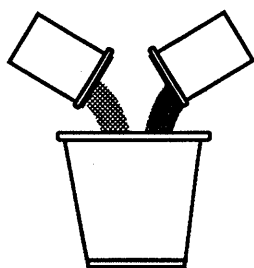

Polyisocyanate and polyol poured into a beaker

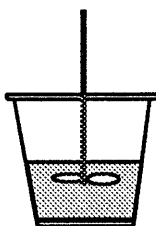

Mixing takes place

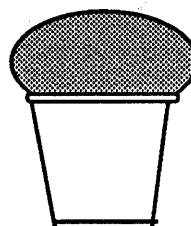

Reaction occurs and the resulting polyurethane rises into a mushroom shape

Making a small sample of polyurethane

Note The materials used in this activity are subject to COSHH regulations and the appropriate safety precautions must be observed.

Autoadhesive

While the polyurethane-making chemical reaction is taking place, the mixture has another interesting and useful property. For a few seconds, when it is almost solid, its surface becomes very tacky so that it will stick to almost any clean, dry, material. This means that it is possible to bond the polyurethane to other materials without having to use a separate adhesive.

General Manufacturing Process

There are two ways of making sports shoes with polyurethane soles :

- **Unit soles** - The uppers and the soles are made separately - even in different countries - and stuck together with a glue. The glue may be another polyurethane or it may be something else altogether. This method is used for the simultaneous production of a variety of models in a wide range of colours. Short runs are possible, allowing greater flexibility.
- **Direct-on moulding** - The upper can be made and then the polyurethane sole moulded in contact with the upper so that its natural adhesive quality makes the two stick together. This eliminates the procedure of sticking sole to upper, which is costly and time consuming, and overcomes the problem of premature detachment of the sole from the upper as a result of adhesive failure. Because the moulds and mould carriers are normally more expensive, this method is usually associated with long production runs.

Student sheet 8 shows the stages of manufacturing a sports shoe and can be used as the basis of a class discussion.

The construction of sports shoe soles

Since there is a need for so many different properties in the ideal shoe sole, it is not surprising that it is not always possible to obtain all of them in a single material. To give the best overall set of properties, the soles of most sports shoes are formed of two components; a **midsole** that provides cushioning and shock absorption and a tougher **outsole** that gives grip and resistance to abrasion. (There is also an **insole**, the part that is next to the foot, but the shoe industry thinks of this as though it were part of the upper, rather than part of the sole.) The first generation of sports shoes used an elastic material, such as a polyurethane elastomer, as a midsole, with a high-density polyurethane or rubber outsole.

These **dual density soles** made it possible to design shoes for particular sports and prompted much research into the requirements of athletic footwear. A cut away example and a diagram showing a section through a heel portion of a shoe are given in **student sheet 9**.

The midsole is the most important technical component of a sports shoe. It has to provide the wearer with cushioning, flexibility and stability when a rapid change of direction is needed. And, if it can retain these properties, under demanding conditions, so much the better. There are three main combinations of materials used in the manufacture of high performance, dual density, soles:

- Two densities of polyurethane
- Polyurethane and rubber
- Ethylene-vinyl acetate copolymer (EVA) and rubber

Polyurethane gives the midsole the best combination of cushioning, elasticity and durability but is heavier than EVA. The latest models feature more highly engineered midsoles which contain inserts such as the 'airbag' in the Nike-Air series. These contain pressurised gases within a thin flexible membrane. Polyurethane elastomers, with their durability, energy absorption and elasticity, can be moulded around these inserts. Thus they offer the shoe designer a cushioning system which is both effective and versatile. Two examples are shown in **student sheet 10**.

Under repeated impact loads, such as those which occur during walking, foam materials eventually break down. Generally speaking, the lighter weight EVA foams break down more quickly than the higher density polyurethane foams. Combinations of polyurethane midsoles with moulded-in airbag inserts are generally more durable and achieve designs in which weight is reduced without any sacrifice in performance.

Heel-strike

When we are walking or running, with each step taken the heel strikes the floor with a high impact force. This impact force, known as *heel-strike*, sends shock waves up the legs. These waves are then transmitted to other parts of the body. This can lead to such injuries as muscle strain, stress fractures, back injuries, damage to cartilages and achilles tendons. Polyurethane soles with integral airbags help to absorb some of the shock from these impact forces and also provide an *energy return* by pushing the foot upwards as it leaves the ground for the next step. **Student sheet 11** contains illustrations of this effect.

Variations in pressure, shape and position of airbags and of the shape, thickness and construction of the sole, enable the designer to tailor the sole so that it matches the exact requirements of specific sports. The variations can also provide extra features to change the appearance of the shoe and give it better aesthetic appeal. **Activity 3** is based around this and **student sheets 9, 10 and 11** should be discussed as preparation.

Activity 3

This is an investigative analysis activity which can be carried out with students working in small groups. It involves an analysis of the lower body movements of athletes in four specific events. This can be done by:

- a) analytical observations at athletics meetings
- b) watching video recordings of athletic events
- c) consulting appropriate training books similar to those used by students studying sports sciences at higher levels.

From this analysis the students are then required to produce a list of desirable properties for sports shoe soles in each event. They are also asked to suggest possible arrangements for air bag inserts in the soles for each event and information is provided in the student sheets to assist with this. There are no single solutions to this activity and it would be a useful exercise to compare and discuss the merits of the different solutions produced by students in order to reach a consensus on what appears to be the *best* solution for each case. Some possibilities are given in appendix 5 of this booklet.

Activity 4

This is an analysis/investigation of forces associated with *heel-strike*. Students can work individually or in small groups on this activity using the background information provided. There are several possible results to this and it would be a useful exercise to discuss the merits of the different responses presented by students. Some possible solutions are shown in appendix 6 of this booklet.

SUPPLEMENTARY ACTIVITIES

SUPPLEMENTARY ACTIVITIES

Activity S1 - Abrasion

Abrasion resistance is a good indication of durability. This activity compares the abrasion resistance of different materials associated with sports shoe soles so as to obtain a comparative indication of durability.

Requirements

1. Samples of solid rubber, PVC and polyurethane sole materials. Perhaps these could be obtained from old, discarded footwear or by contacting a shoe manufacturer.
2. Abrasive paper such as coarse glass paper, garnet paper or emery cloth.
3. Base board of a suitable size to fix the abrasive paper down.

Method

1. Fix the abrasive paper to a base board either by glue or use of drawing pins.
2. Weigh each sample of material.
3. Rub each sample back and forth on the abrasive paper for a specified number of times over a set distance.(e.g. 50 times over 200 mm).

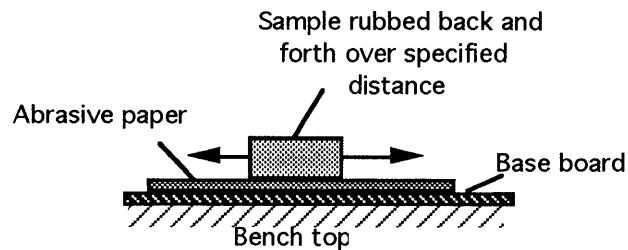

4. Re-weigh each sample after abrasion and hence determine the weight loss. Comparison of weight losses will give an indication of comparative durability - the material with least weight loss being the most durable.

Conclusions

Present your results in some form of graphic display and write a short comparative report on the suitability of the materials for use in sports shoes.

Activity S2 - Slip resistance

Slip resistance of a sole is particularly important in sports shoes and is influenced by a range of complex factors which can be collated into three broad categories.

1. *Design* - this includes the design of the sole pattern, construction of the sole and the style of the shoe. The combination of these factors determine the contact surface and the direction of forces applied whilst walking or running.
2. *Surface* - this includes the type of contact surface, its roughness and environmental factors, and anything which might form a lubricant between sole and contact surface.
3. *Soling Material* - the properties of the material used and how these may be affected by wear.

Related Theory

Slip resistance is usually assessed by determining the coefficient of friction, μ . This is defined as the ratio of F/N where N is the reaction of a sample normal to the surface on which it rests and F is the force required to move the sample relative to the surface.

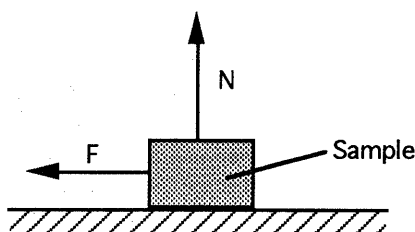

$$\text{Hence } \mu = \frac{F}{N}$$

Two types of friction are usually considered and are known as **static** friction and **dynamic** friction.

$$\text{For static friction: } \mu = \frac{F_s}{N}$$

where F_s , is the force required to initiate movement of the sample (i.e. at the point where the applied force just overcomes the frictional force and the sample begins to move over the surface).

$$\text{For dynamic friction: } \mu = \frac{F_d}{N}$$

where F_d is the force required to move the sample over a surface at a given constant speed.

It is generally accepted that for average persons the static coefficient of friction for footwear should be greater than 0.3 to prevent slip from starting. The dynamic coefficient of friction should also be larger than 0.3 so as to quickly stop slip should it occur.

For the purposes of this activity you will only consider static friction in order to obtain comparative results for three sample materials under three different conditions (on dry, wet and oily surfaces).

Requirements

1. Samples of solid rubber, PVC and polyurethane sole materials. Perhaps these could be obtained from old, discarded footwear or by contacting a shoe manufacturer.
2. An unglazed ceramic floor tile (available from hardware stores).
3. Base board of a suitable size to mount the ceramic tile.
4. Protractor or other similar instrument for angular measure.

Method

Fix the ceramic tile to the base board with a suitable adhesive.

For a clean dry surface:

1. Rest the sample under test on the surface of the tile in a horizontal position on the bench top.
2. Slowly lift one end of the base board so the tile and sample move into a sloping position.
3. At the point where the sample just begins to slide over the tile surface measure the angle of inclination of the slope to the horizontal.

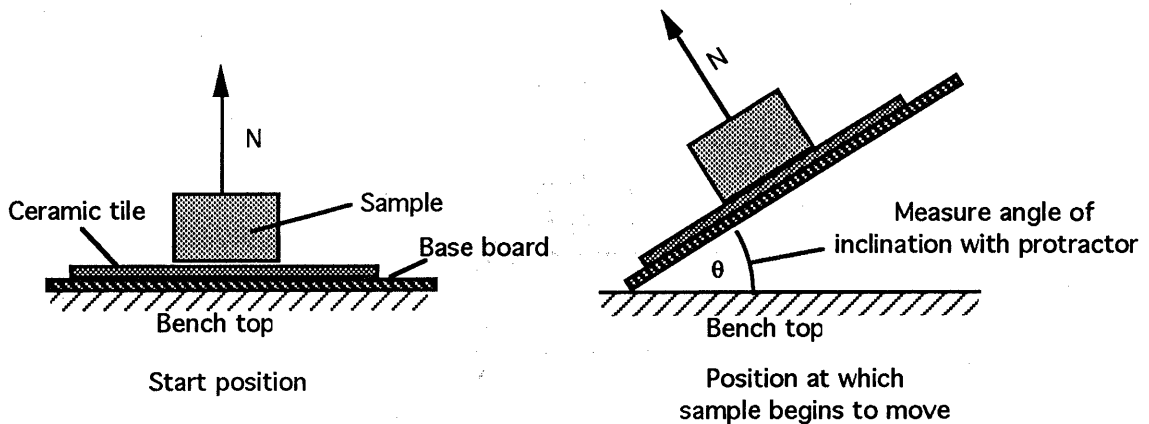

4. Repeat the procedure to give three results for the angle and calculate the average of these to give a final result.
5. The tangent of the final angle gives the coefficient of friction for the sample. (i.e. $\mu = \tan \theta$)
6. Repeat the test procedures for each of the sample materials and record your results.

For a wet surface:

Wet the surface of the tile with water and repeat the whole series of tests with each sample and record your results.

For an oily surface:

Smear the surface of the tile with oil and repeat the whole process again, recording your results.

Conclusions

Display the overall results by some graphical means. Write a short report on the suitability of the materials for use in the soles of sports shoes based on your results and the information given on static coefficient of friction.

Related Theory

At the point where the test piece begins to slide, the frictional force, F , is equal to the component of weight in the plane of the friction surface. In calculating the coefficient of friction, the load which has to be used is the force acting at 90° to the friction surface (Normal force, N). For horizontal surface tests, the weight of the sample is the effective normal force. On inclined surfaces, the normal load is related to the weight and the angle of inclination.

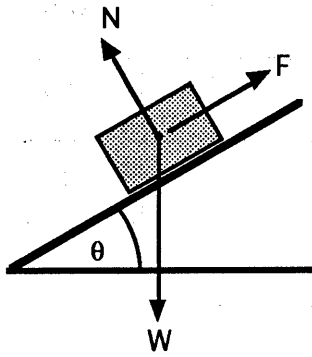

W = weight of test specimen

θ = angle of inclination at point of slipping

N = force normal to inclined surface
 $= W \cos \theta$

F = frictional force in the plane of inclination
 $= W \sin \theta$

Calculation

$$\begin{aligned} \text{coefficient of static friction } (\mu) &= \frac{F}{N} \\ &= \frac{W \sin \theta}{W \cos \theta} \\ &= \tan \theta \end{aligned}$$

Further investigation

A similar activity can be designed to investigate the effect of different tread patterns on slip resistance using actual sports shoes under the same conditions as above (on dry, wet and oily surfaces).

**Comparison of properties of different
microcellular midsoling elastomers**

Properties	Units	EVA	Micro- porous Rubber	Standard PU	Low Density PU
Density	kg/m ³	250	350	450	300*
Hardness	Asker C	70	70	70	70
Tear strength	kN/m	4	6	6	5
Tensile	MPa	3	4	5	4
Elongation	%	250	190	380	320
Compression-set	%	16	14	4	4
DIN-Abrasion Test	m g	406	208	180	250

*

It is expected that this figure will be reduced to 250 as technology develops

Other Applications of 'Blown' Polyurethane

The matrix diagram below gives you an indication of the sort of applications that different sorts of polyurethanes (rubbery or hard or somewhere in between) : blown to different degrees, can be used for.

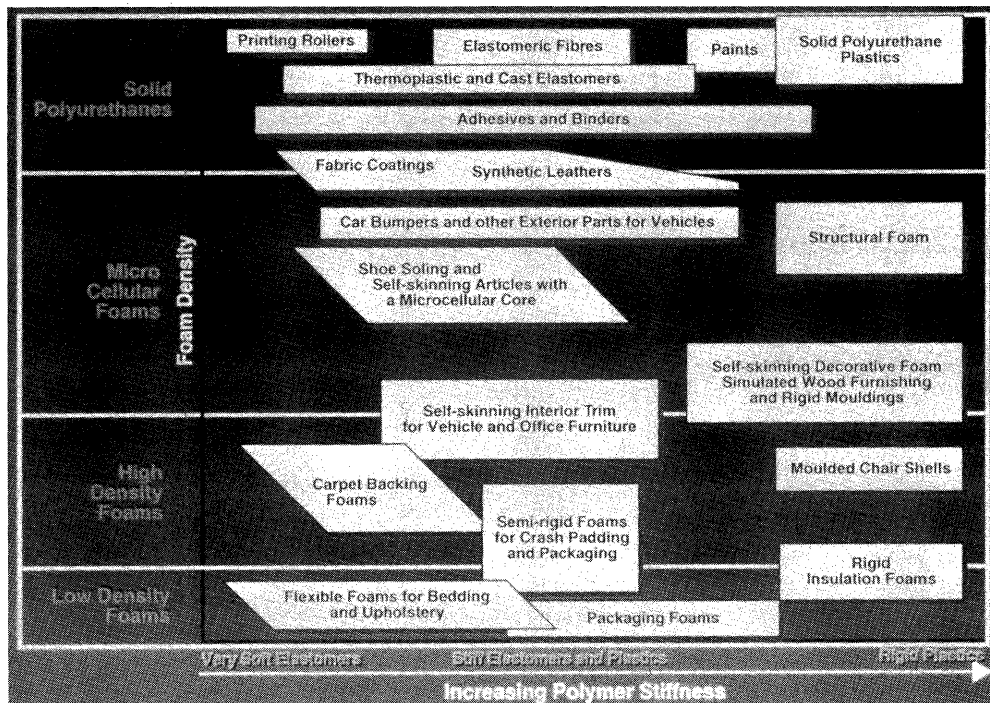

Polyurethanes 'property - application' matrix

Materials Supplies

Teacher Demonstration

The materials for this practical demonstration can be obtained as a two part polyurethane foam mix from the following company:

Trylon Ltd
Thrift Street
Wollaston
Northants
NN9 7QJ

Tel: 0933 664275

2

List of Student Sheets

1. Materials Selection in Product Design
2. Development of a New Product
3. Soles and Uppers
4. Activity 1
5. General Functional Requirements for Shoe Soles
6. Materials used in Shoe Soles
7. The Case for Polyurethane + Activity 2
8. General Manufacturing Process
9. The Construction of Sports Shoe Soles
10. Air Bag Inserts
11. Heel-Strike + Activity 3
12. Activity 4

Some Suggestions for Student Activity 3

Part 1.

Consider the following aspects:

- a) Hard or soft depending on whether energy return is required?
- b) Flexible or stiff?
- c) Grip?
- d) Also refer to *General Functional Requirements* list (student sheet 5).

Part 2.

Airbag inserts can be in any 1 of 3 possible combinations:

- a) Heel only
- b) Ball of foot only
- c) Both heel and ball of foot

Part 3.

The properties of the material can be varied to suit the particular requirements of individual activities.

Possible Solutions to Student Activity 4

Heel Strike Shock Transmission Paths



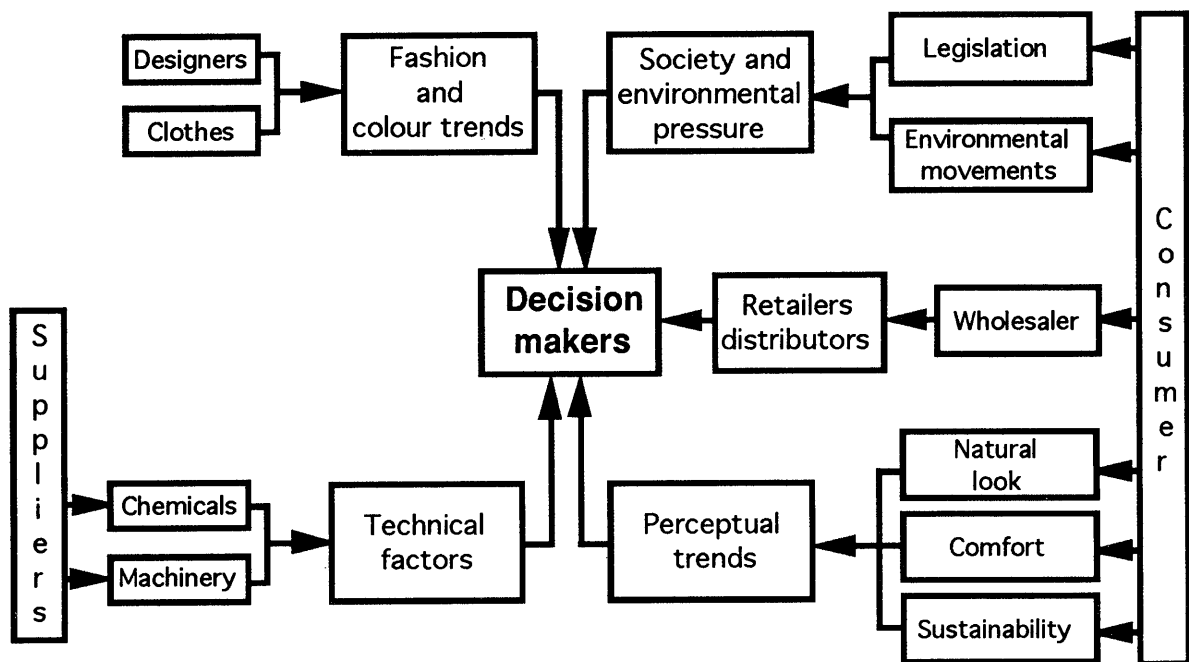

Factors influencing the development of a new product

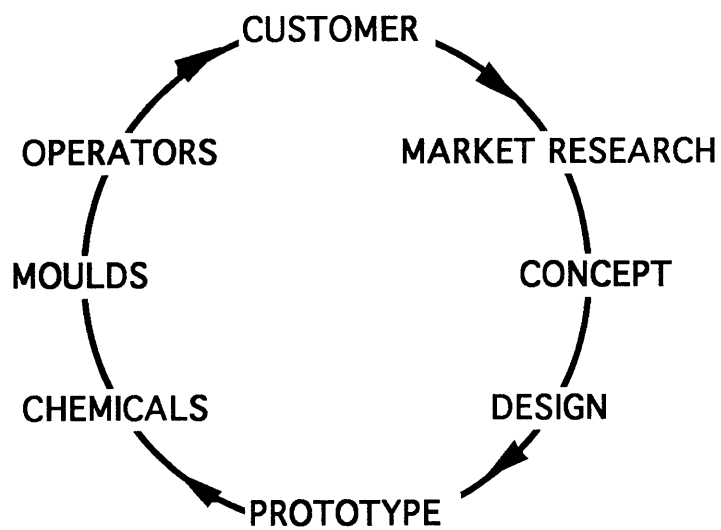

New Product Path

GG8. 4239 STA

KW = POLYURETHANE

= PLASTIC

= RUBBER

OHP 2

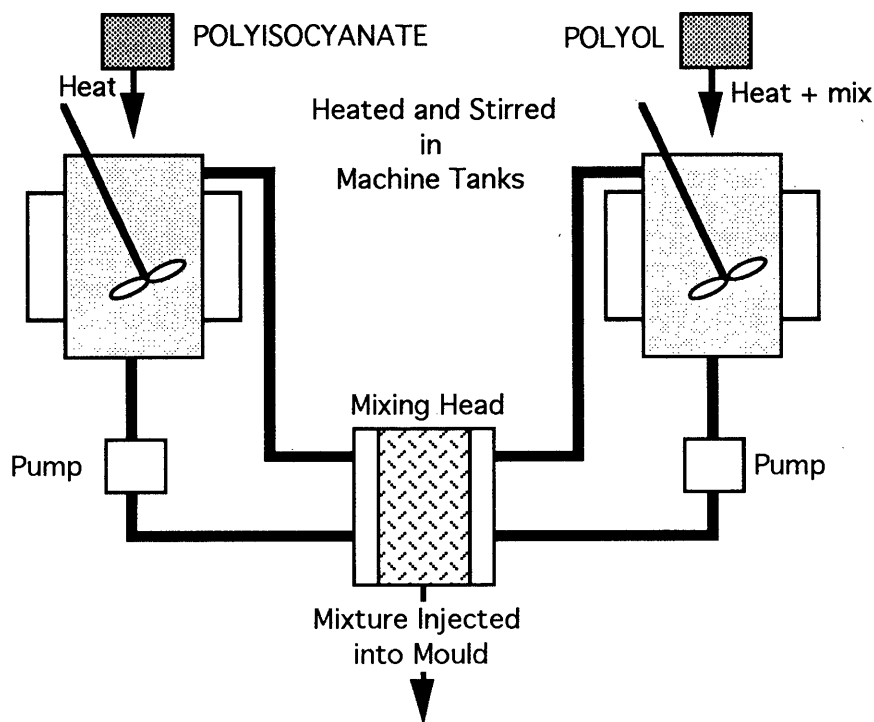

Schematic diagram of industrial production

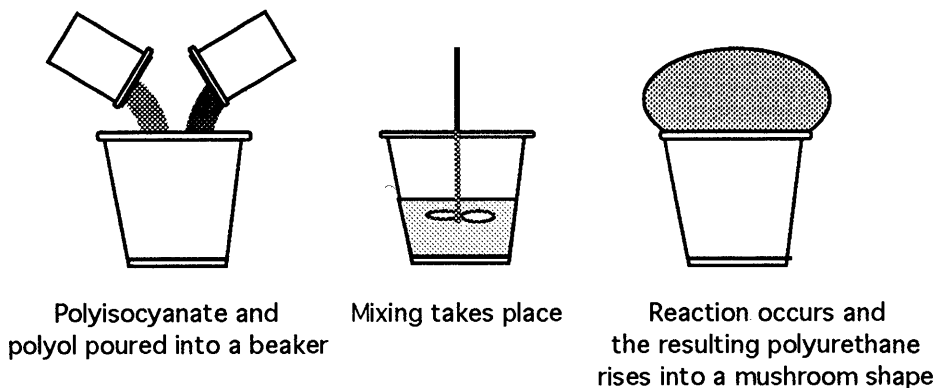

Making a small sample of polyurethane

Polymer Industry Education Centre
Department of Chemistry
University of York
Heslington
York
YO1 5DD

Materials Selection in Product Design

When designers are considering which materials to select for a particular product they normally consult experts in materials whose advice will influence the development process. Two of the main considerations are:

- Materials must have properties which allow the designer to produce a required effect.
- The choice of material will influence the manufacturing methods and vice-versa.

When selecting materials for specific products the designer must consider which one offers the best balance of properties. Some of the main factors to be taken into account are:

- Appropriateness for the manufacturing process and quantity production (machining, moulding, extrusion, etc.)
- Physical properties of the material (strength, hardness, chemical resistance, etc.)
- Material form (sheet, rod, strip, liquid, etc.)
- Aesthetic considerations such as colour, texture, pattern and shape.
- Environmental considerations such as weather resistance and ease of recycling.
- Safety such as flammability and toxicity.
- Thermo-electrical and acoustic properties
- Cost and availability

General Functional Requirements for Shoe Soles

1. **Weight:** If shoes are heavy, walking, running or any sporting activity will make the wearer tired more quickly. So a light weight material is an advantage.
2. **Toughness:** Every time you take a step your shoe sole is bent and then straightened. So in the shoe's lifetime the sole may be bent many thousands of times and it has to withstand this rough treatment without cracking. Moving over rough (perhaps stony) ground, will bend the sole in different directions, and adds to the need for a tough material.
3. **Flexibility:** Where the foot needs to bend, the sole needs to copy the natural movement of the foot, for example gymnastics. In these cases the sole should be flexible. On the other hand, sometimes the sole has to protect the foot against too much bending, for example when fell walking, where it may be necessary to have a rigid sole.
4. **Insulation:** When the ground is very cool (or very hot !) the sole can protect the foot against it. For this the sole needs to be made of a good insulation material.
5. **Waterproof:** Even if you can be sure that you will never wear the shoes in the rain, some protection against walking over wet ground is an essential feature of most shoes.
6. **Comfort:** Difficult to define but you soon find out whether shoes are uncomfortable.
7. **Slip resistant:** the ability to grip the ground without slipping is essential for most footwear. However, playing squash requires an element of slip.
8. **Resistance to abrasion:** If the ground you walk over rubs away the material that your shoe soles are made of they will wear out much too quickly.
9. **Shock absorbent:** There are two factors to be considered here. Some materials that are quite strong will crack easily if a force is applied to them quickly. Glass, for instance, wouldn't be very useful as a shoe sole material! Shoes are more comfortable if they absorb the shock each time your foot is put on the ground, rather than simply transferring that shock to your foot.
10. **Energy recovery:** Each time you put your foot down the shoe sole absorbs a little energy as it is squashed between the foot and the ground. Some materials simply lose that energy while others give it back to you by pushing the foot upwards at the beginning of the next step. Since all the energy involved in walking or running or jumping comes from your legs, a material that gives back most of that energy helps you not get tired so quickly.

Materials used in Shoe Soles

Traditionally leather and rubber were used for shoe soles but with the development of new materials this has slowly changed. The table below illustrates the development and introduction of other materials since 1930.

Major Footwear Soling Materials Since 1930

1930	1940	1950	1960	1970	1980	1990
Leather Rubber (natural)	Leather Rubber (natural/ vulcanised)	Leather Rubber (natural/ vulcanised)	Leather Rubber (natural/ vulcanised) PVC	Leather Rubber (natural/ vulcanise) PVC PU TPR	Leather Rubber (natural/ vulcanised/ latex) PVC PU TPR EVA	Leather Rubber (natural/ vulcanised/ latex) PVC PU TPR EVA

Some characteristics which account for the use of these materials are as follows:

- Leather - has a natural quality
- Rubber - for toughness
- Polyvinyl Chloride (PVC) - is cost effective
- Polyurethane (PU) - combines lightness and comfort
- Thermoplastic Rubber (TPR) - is a thermoplastic with a natural feel
- Ethylene-Vinyl Acetate (EVA) - for lightness

The Case for Polyurethane

Designers now use a range of plastics for all components in shoe design. The main use of polyurethane in footwear has been as a soling material. Two reasons for this are its durability and cushioning property (cushioning properties have recently become quite important in footwear).

The following properties of polyurethane relate to its general use for shoe soles:

- light weight material
- tough
- good flexibility
- good insulation properties
- waterproof
- comfortable
- slip resistant
- hard wearing and abrasion resistant
- good shock absorbent qualities (especially when foamed)
- good energy recovery characteristics
- can be given UV stability by the use of additives
- can be given anti-microbial properties

It is also easy to adjust the following characteristics of polyurethane to suit specific products:

- hardness
- density
- feel
- colour
- resilience
- flexibility
- performance properties (wear/slip/degradation/abrasion)
- UV stability
- anti-microbial properties

Activity 2

1. From the 'general functional requirements for shoe soles' identify those aspects which particularly apply to sports shoes (trainers).
2. Compare these aspects with the list of polyurethane properties given above for general use in shoe soles and hence write a short report outlining the reasons why polyurethane is a suitable material for the soles of training shoes.

General Manufacturing Process

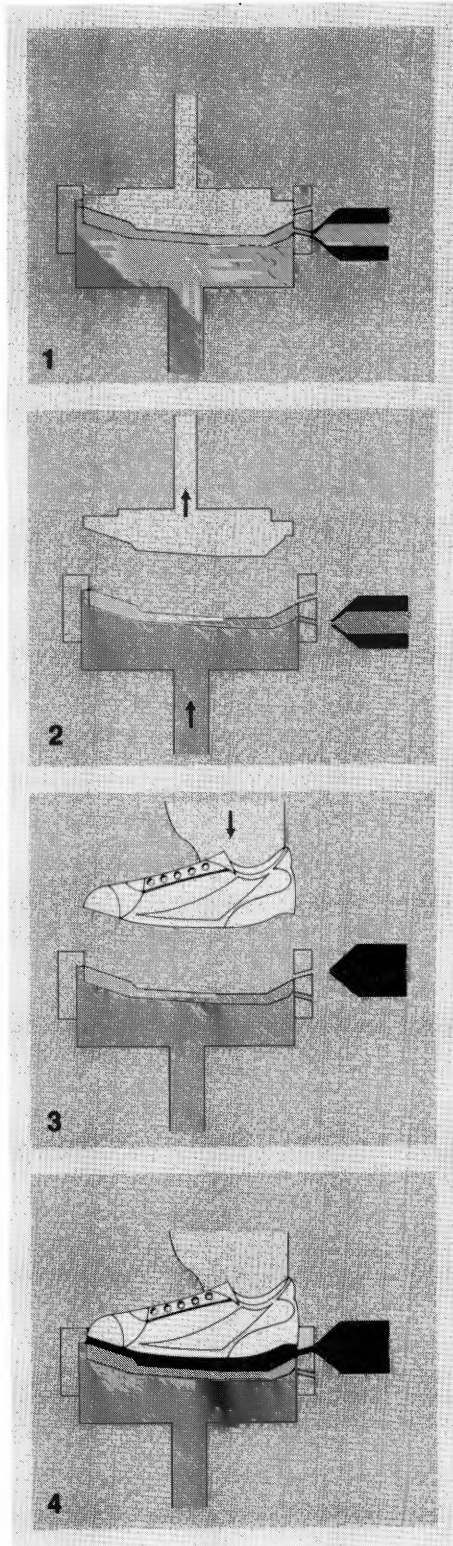

Injection of outsole

The Base moves up to seal the sprue gate after injection and the mould then opens

Upper is introduced into mould

Injection of mid sole, bonding outsole to upper

Sequence of production

The Construction of Sports Shoe Soles

To give the best overall set of properties, the soles of most sports shoes are made of two components. These are, a **midsole** that provides cushioning and shock absorption and a tougher **outsole** that gives grip and resistance to abrasion.

The first generation of sports shoes used a soft elastic type of polyurethane for the midsole, with a stiffer high-density polyurethane, or rubber, for the outsole. These **dual density soles** made it possible to design shoes for particular sports and other activities and led to more research into the requirements of athletic footwear.

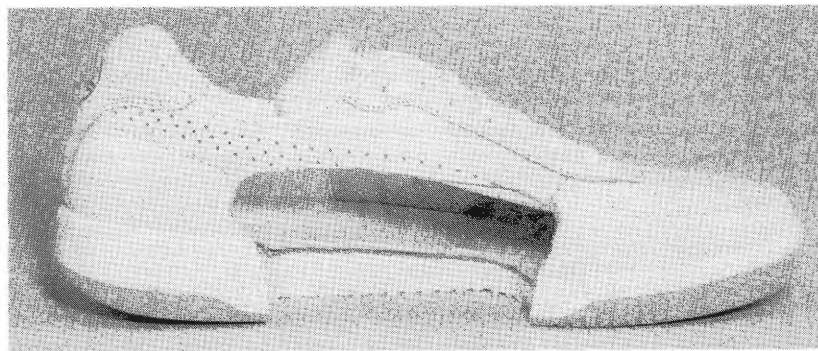

Section showing the layers of a sports shoe sole

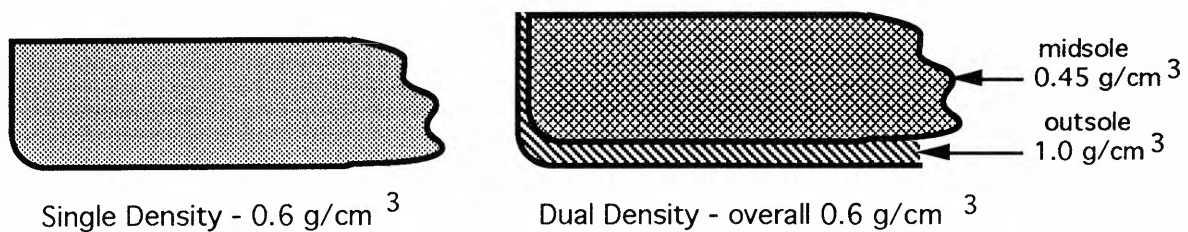

Section through two heel portions comparing single and dual density soling

The midsole is the most important component of a sports shoe. It has to provide the wearer with cushioning, flexibility and stability when a rapid change of direction is needed. There are three main combinations of materials used in the manufacture of high performance, dual density, soles :

- Two densities of polyurethane
- Polyurethane and rubber
- Ethylene-vinyl acetate copolymer (EVA) and rubber

Polyurethane gives the midsole the best combination of cushioning, elasticity and durability but is heavier than EVA.

Air Bag Inserts

The latest models contain inserts such as the 'air-bag' in the Nike-Air series. These contain pressurised gases which provide a very effective cushioning system. The manufacturing process is slightly different in that the air-bags are positioned in a mould containing the outsole and the polyurethane mid-sole is poured around them. The upper is then positioned as the foam forms, making use of the autoadhesive property.

Variations in pressure, shape and position of airbags and of the shape and thickness of the sole, allow the designer to tailor the sole to match the exact requirements of specific sports.

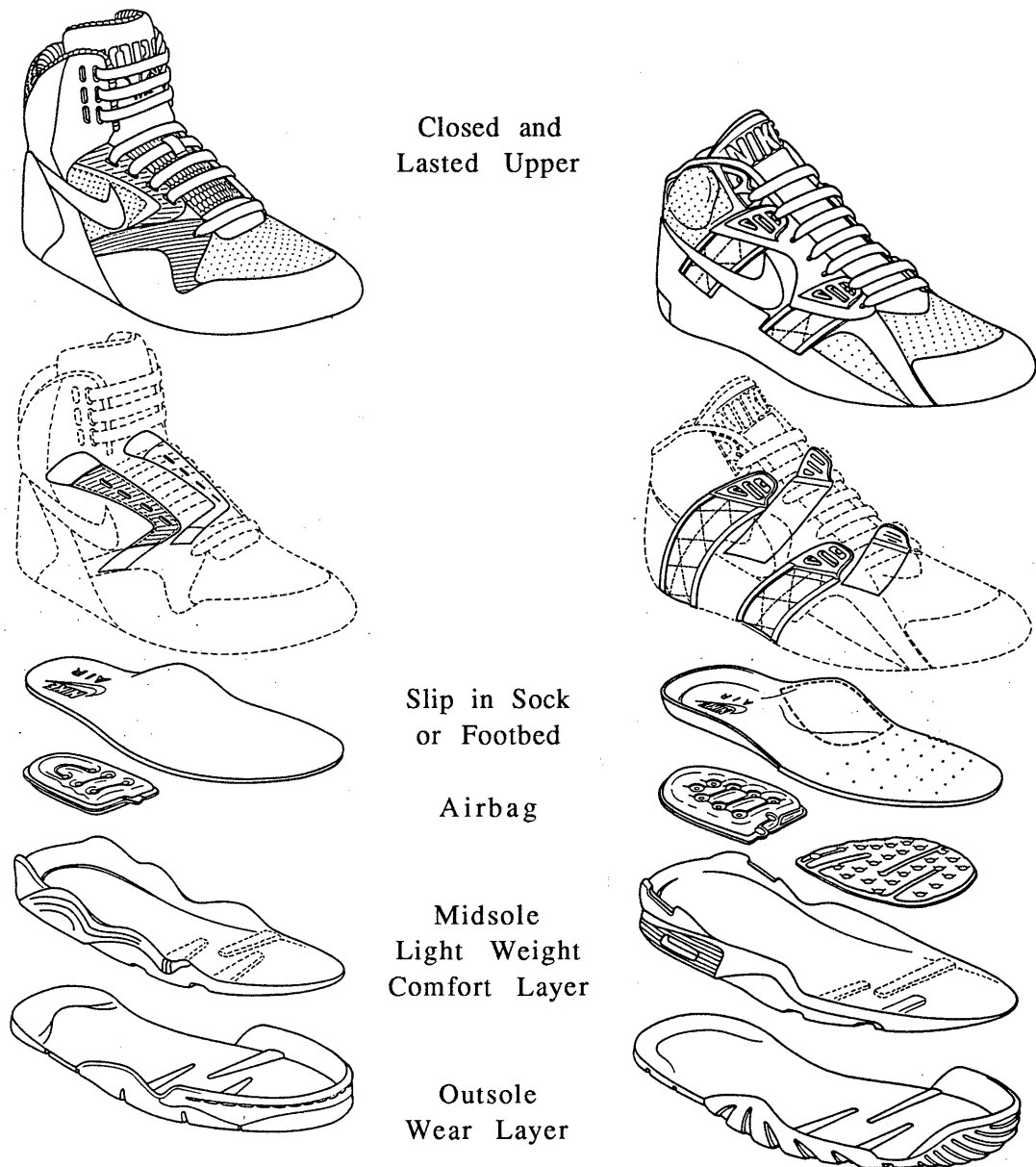

Examples showing two possible air-bag/sole arrangements

What would be a possible third arrangement ?

Heel-Strike

When we are walking or running, the heel strikes the floor with a high impact force. This impact force is known as *heel-strike* and sends shock waves up the legs. Polyurethane soles with integral airbags help to absorb some of the shock from these impact forces and also provide an *energy return* by pushing the foot upwards as it leaves the ground for the next step.

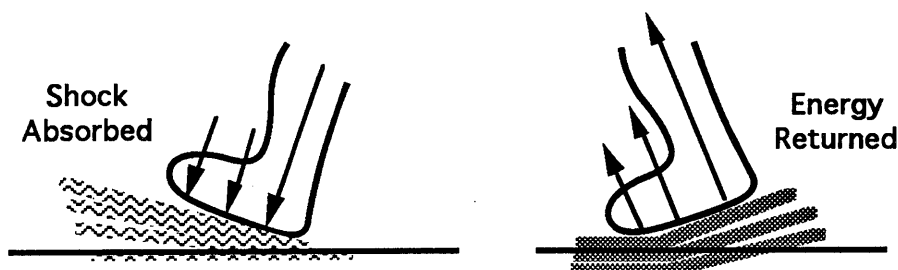

Activity 3

Sprinters and jumpers prefer hard soles which do not waste the power from their leg muscles by absorbing the impact forces - the harder the soles, the greater the reaction (*energy return*) to the force of the foot coming down on the track, thereby achieving a better performance. However, long distance runners would suffer with hard soles because of the prolonged jolting to the limbs.

1. Analyse the nature of the movement and physical demands on athletes feet and legs in the following athletic events:
 - a) 100m sprint
 - b) discus throw
 - c) long jump
 - d) marathon

From this analysis produce a tailored list, for each event, of desired properties for the sports shoe soles involved, shown in order of importance

2. Suggest what you think might be the most suitable training shoe airbag insert arrangements/combinations for each of these athletic events.
3. What particular characteristic of polyurethane makes it ideally suitable for producing a variety of soles for different requirements?

Activity 4

Heel strike can send damaging shock waves up the legs. These waves are then transmitted to other parts of the body. Measurements taken at various points in the human body using sophisticated equipment show that these shock waves can cause the following:

- bowing of the legs
- damage to discs in the spine (back injuries)
- jolting at the lower part of the brain

On the diagram of an athlete below draw in arrowed lines to show the paths which you think the shock waves might take as they transmit upwards through the body to the neck region. One line is drawn as an example, showing the transmission of heel strike shocks to the knee.



Development of a New Product

Sports shoe design involves the following two aspects:

- Designs for the soles
- Designs for the uppers

The design and development cycle (or lead time) for a new product in the sports shoe industry usually takes about six months. The diagram below illustrates the various stages of this process.

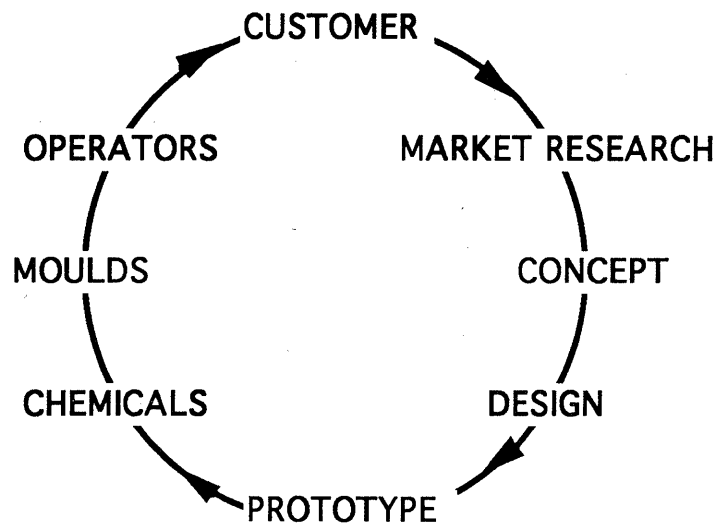

New Product Path

The aspects which influence a new sports shoe design can be grouped into factors **leading** to production and factors **controlling** production are shown below.

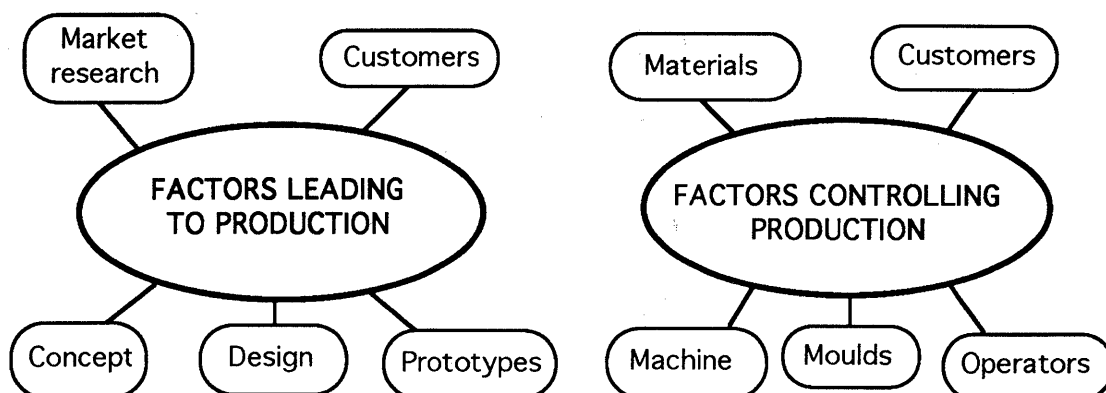

Factors Related to Production

Soles and Uppers

In some sports soles must be highly flexible and the designer must be careful to avoid tread patterns which would cause a build up of uneven stresses and strains in the sole. This would cause areas of local stress to develop when the shoe is flexed.



Flexibility of soles

If areas of local stress build up what do you think will happen to the sole of the sports shoe?

Once the tooling has been set up to produce a particular sole it is possible to develop related but different upper designs for bulk production in less than three weeks.



Different Upper Designs

Activity 1

The development of a new sports shoe design will be influenced by the following factors:

- Consumer requirements
- Fashion and colour trends
- Demands of retailers and distributors
- Society and environmental pressures
- Properties of materials
- Technical aspects of manufacturing processes

Carry out a survey of existing sports shoes in order to develop a marketing strategy for a new product line. Your market research should investigate the following:

- consumer attitudes and preferences
- an examination of existing uppers styles and tread patterns of soles
- current costs to the consumer.

