



MANTLE BENCH

The Mantle Bench is a versatile seat and surface, handcrafted using sustainable British deerskin and natural upholstery fillings. Precisely cut panels of soft yet durable suede convene along parallel lines of tone-on-tone stitching to create an exacting cover that drapes neatly over its solid beech frame. The seams conclude in knife-cut raw edges to reveal a glimpse of the masterfully hand-turned legs beneath – and add fluidity to each face, celebrating the innate nuances of the naturally tanned hides.

- Handmade in London
- All pieces made to order in 10-12 weeks

DIMENSIONS:
130cm (W) x 45cm (D) x 43 (H)

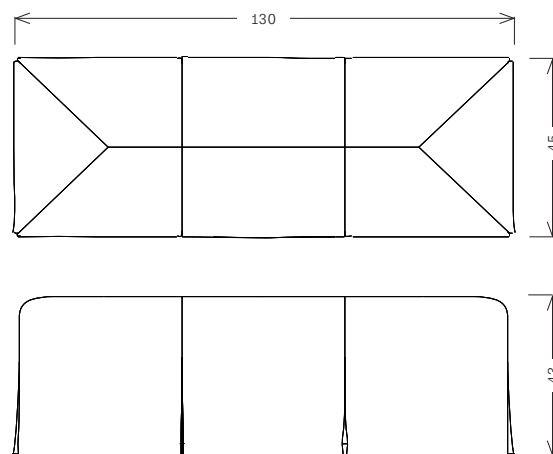

CONSTRUCTION

Solid Beech frame with hand-turned legs in solid Oak or solid Walnut.

UPHOLSTERY

Traditionally webbed seat with all natural upholstery fillings combining hair, latex and wool. Free from FR chemicals when upholstered with Billy Tannery suede.

LEATHER / SUEDE

Supplied by Sedilia or COL
Requires 52 sq.ft of leather / suede

TIMBERS

-  Solid European Oak
Natural Oil Finish
-  Solid European Black Walnut
Natural Oil Finish
-  Solid European Black Walnut
Smoke and Oil Finish