

ALANA DESK

Assembly Instructions

URBAN OUTFITTERS

NO ADDITIONAL TOOLS REQUIRED.

WARNINGS:

At least two people recommended for assembly
Do not throw away packing materials and carton until after assembly.
Ensure all parts are present prior to assembly.
Contact customer service immediately if parts are missing.
Assemble all parts on a clean smooth surface
Do not drag the table while moving.

CARE INSTRUCTIONS:

Avoid direct exposure to sunlight.
Do not place overheat or air conditioning vents.
Adjust levelers so that the furniture sits flat on uneven floors.
Blot spills with a clean white cloth, do not rub.
Do not use harsh chemicals.
Before cleaning any part test a small spot in a hidden area.
You may need to re-tighten all bolts after initial use.

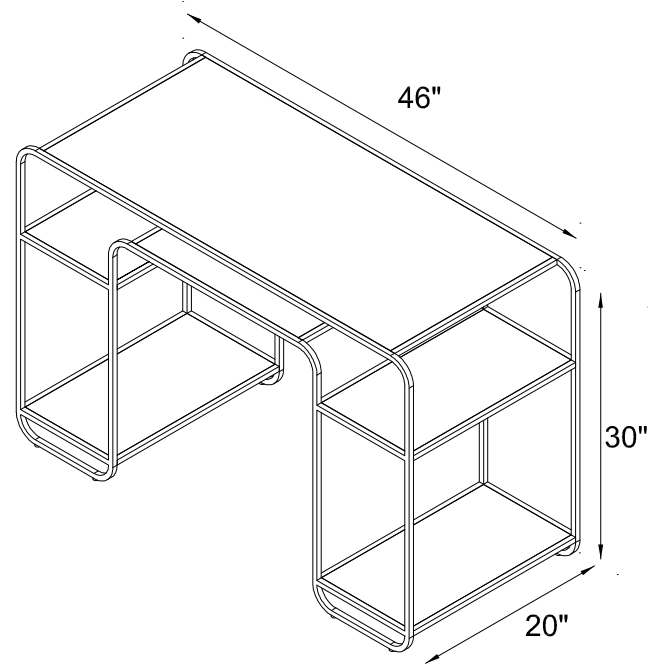

PARTS INCLUDED

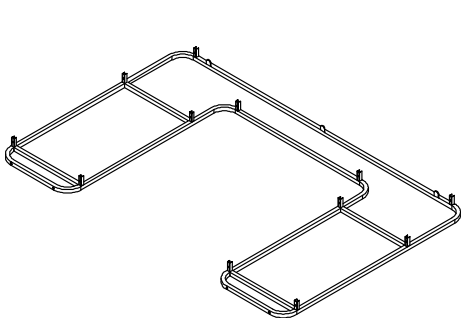

A) Metal Front Frame x2



B) Cross Rail x12

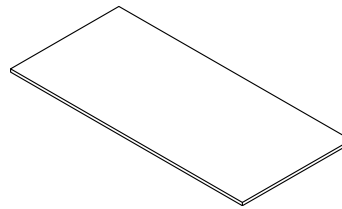

C) Top Metal Shelf

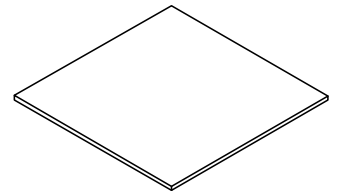

D) Middle Shelf

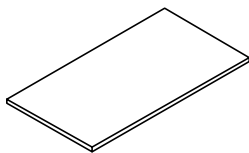

E) Side and Bottom Shelf x4

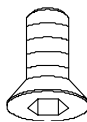

F) Bolt [M5x10mm] x24



G) Allen Key

STEP 1

Lay down all the parts on the clean carpet or cardboard for assembly. Remove plastic protective caps from metal frames (A). Align metal frame (A) with cross rail (B). Insert bolts (F), and partially tighten with Allen key (G). Once all bolts are inserted and partially tightened, fully tighten the bolts.

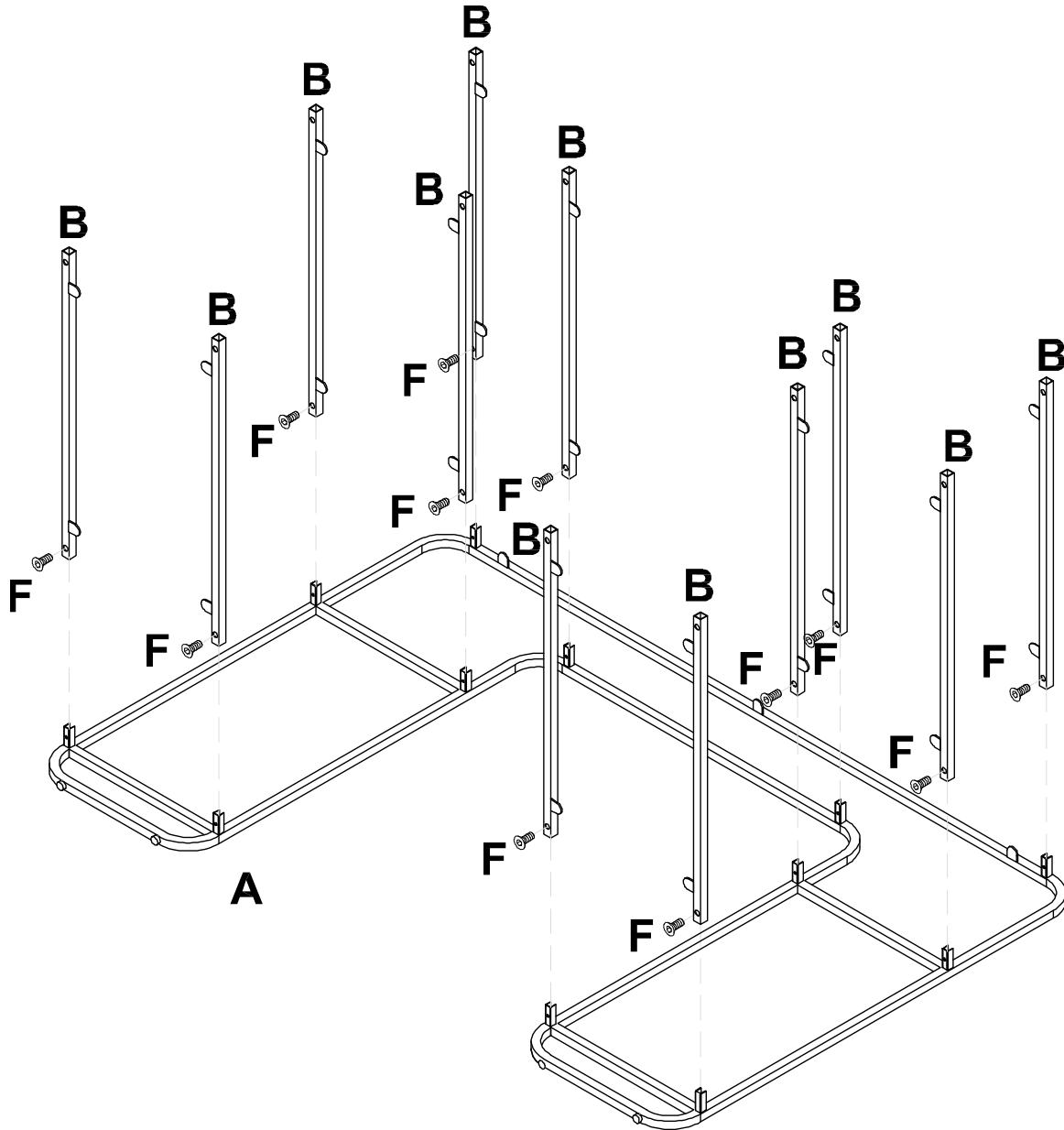

STEP 2

Align metal frame (A) with cross rail (B). Insert bolts (F) and partially tighten with Allen key (G). Once all bolts are inserted and partially tightened, fully tighten the bolts. With help, flip the desk upright.

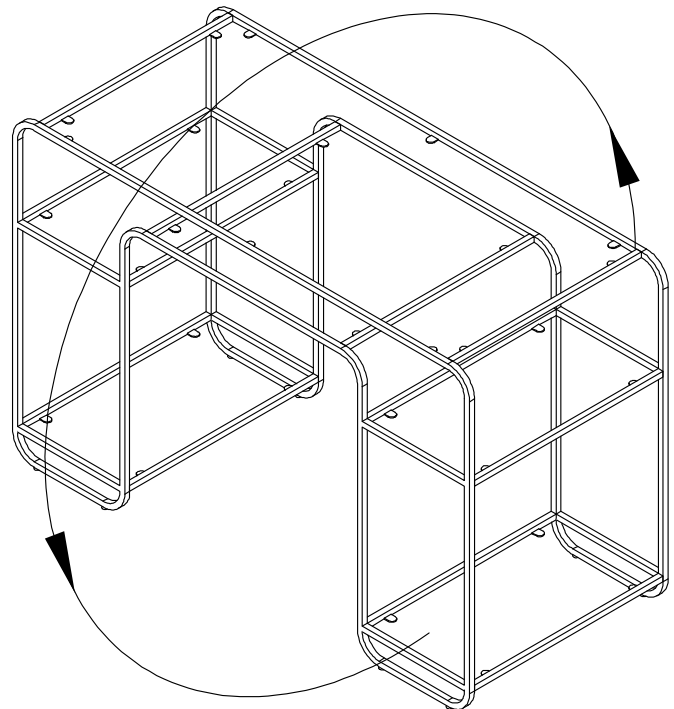
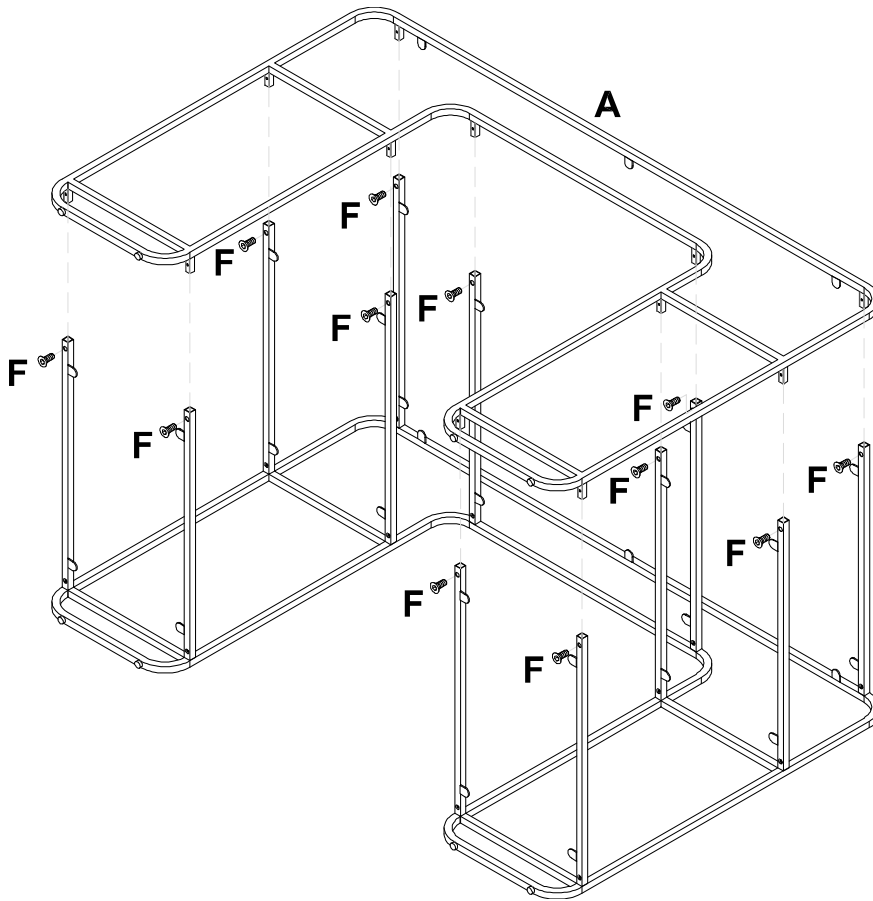

ALANA DESK

Assembly Instructions

URBAN OUTFITTERS

STEP 3

Insert side and bottom shelves (E) on the partially assembled frame as shown. Insert top (C) and second shelf (D) on assembled frame as shown.

