



Optimum working height when sitting...



... and also standing

Lift Systems

Movotec

Height-adjustable systems for optimum ergonomics.
Loads of up to 450kg.

Movotec - Bolt-On and Corner Leg System.

Ease and convenience at your place of work

Movotec is an ergonomic height-adjustment system for all kinds of tables and machinery with large loads. The Movotec Bolt-on system can be retrofitted to existing tables with minimal effort. In addition, complete table solutions for 2-4 leg applications are available with Corner Leg and A.T.U. Lift Systems.

Features

- Height adjustment with four legs possible for weights up to 450kg
- Standard adjustment ranges of 150mm - 400mm
- Available with electric motor or manually operated with hand crank
- Retrofitting option for existing tables
- Low effort required for height-adjustment with hand crank and motor options
- Combination option of up to eight cylinders in order to handle larger weights (max. approx. 900kg)
- Complete systems available including accessories for assembly
- Engineered solutions also available

Applications

- Workbenches
- Production lines
- Massage beds
- Operating tables
- Machinery and many more



Supply contents of the complete systems.

System includes

- Crank or motor driven unit
- Two 2.5m sections of flexible tubing
- Two 3m sections of flexible tubing
- Four Bolt-On cylinders or four Corner Leg cylinders
- Four Corner Leg housing units
- Four glides
- Tubing clips (adhesive packed) and cable ties
- Four 13mm retaining rings (Corner Leg only)
- Sixteen T25 Torx screws (Corner Leg only)



Bolt-On
with hand crank



Corner Leg
with hand crank



Bolt-On
with motor driven unit



Corner Leg
with motor driven unit

	System Lift Capacity (kg)	Adjustment Range (mm)	CB „Bolt-On“ Cylinder		Crank driven system			Motor driven system	
			A (mm)	B (mm)	Part Number	X (mm)	Y (mm)	Part Number	Z (mm)
Corner Leg	340	155			MSY-03856	344.5	328.5	MSY-04390	375
	340	195			MSY-03857	404.5	388.5	MSY-04391	435
	340	300			MSY-03858	586.5	570.5	MSY-04392	617
	340	400			MSY-03859	714.5	698.5	MSY-04393	745
Bolt-On	340	155	258.5	165	MQS-00001	344.5	328.5	MQS-00008E	375
	340	195	333.5	240	MQS-00002	404.5	388.5	MQS-00009E	435
	340	300	463.5	340	MQS-00003	586.5	570.5	MQS-00010E	617
	340	400	558.5	340	MQS-00004	714.5	698.5	MQS-00011E	745
	454	150	258.5	165	MQS-00005	404.5	388.5	MQS-00012E	435
	454	230	463.5	340	MQS-00006	586.5	570.5	MQS-00013E	617
	454	305	463.5	340	MQS-00007	714.5	698.5	MQS-00014E	745

All dimensions in mm.

Crank driven system



Motor driven system



Bolt-On

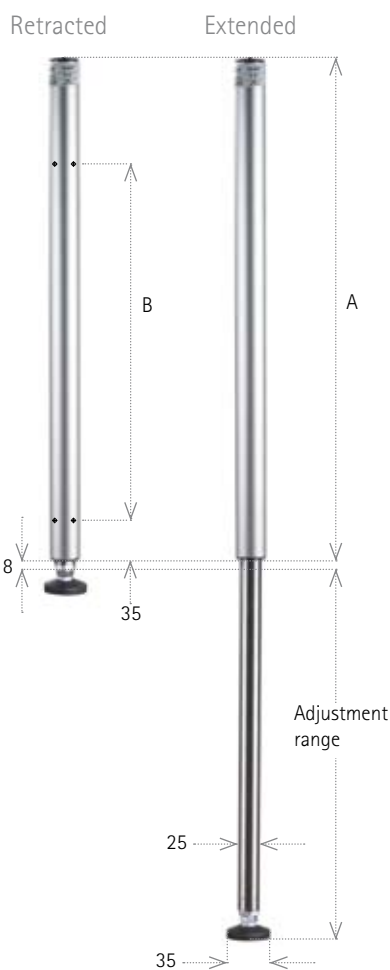

Corner Leg

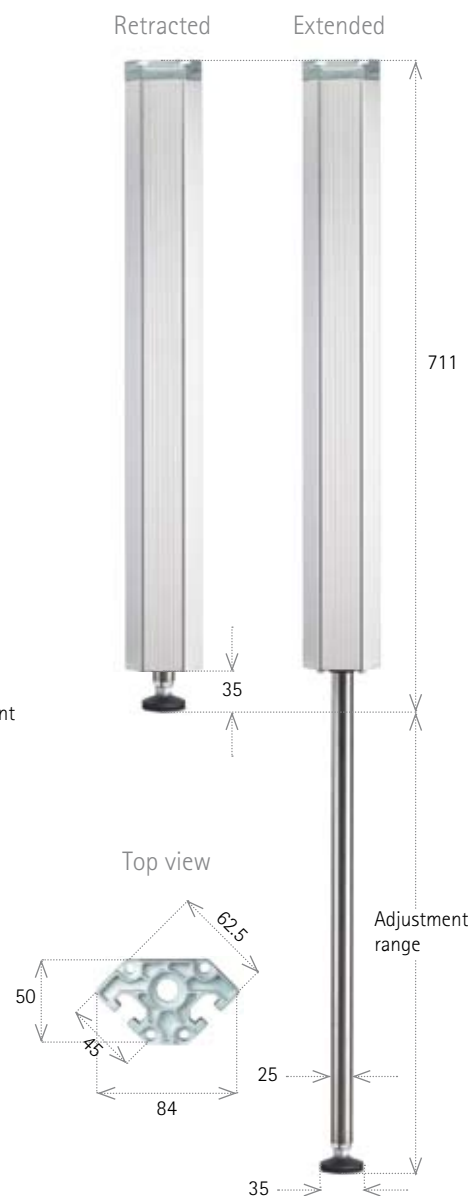

Movotec

Height adjustable systems up to 450kg

With smooth telescoping movement and rigid structural integrity, our two-piece anodized aluminum extrusion was designed to support the application of Movotec CE cylinders. Engineered to be used as a free-standing leg unit or external guide mechanism, the A.T.U. supports the use of many types of brackets, hardware or other structural components. For O.E.M. applications only.



Technical Data

Materials: extruded aluminum with clear matte anodized finish

Adjustment range: 300mm
600mm fully compressed
900mm fully extended

Adjustment range: 200mm
500mm fully compressed
700mm fully extended

Operating temperature range:
0°C to 46°C

Designed to be used with Movotec CE cylinders

Inner and outer frame

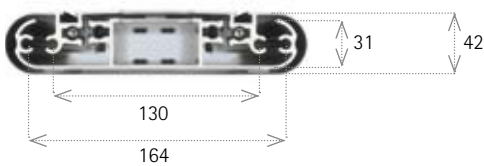

extended

retracted

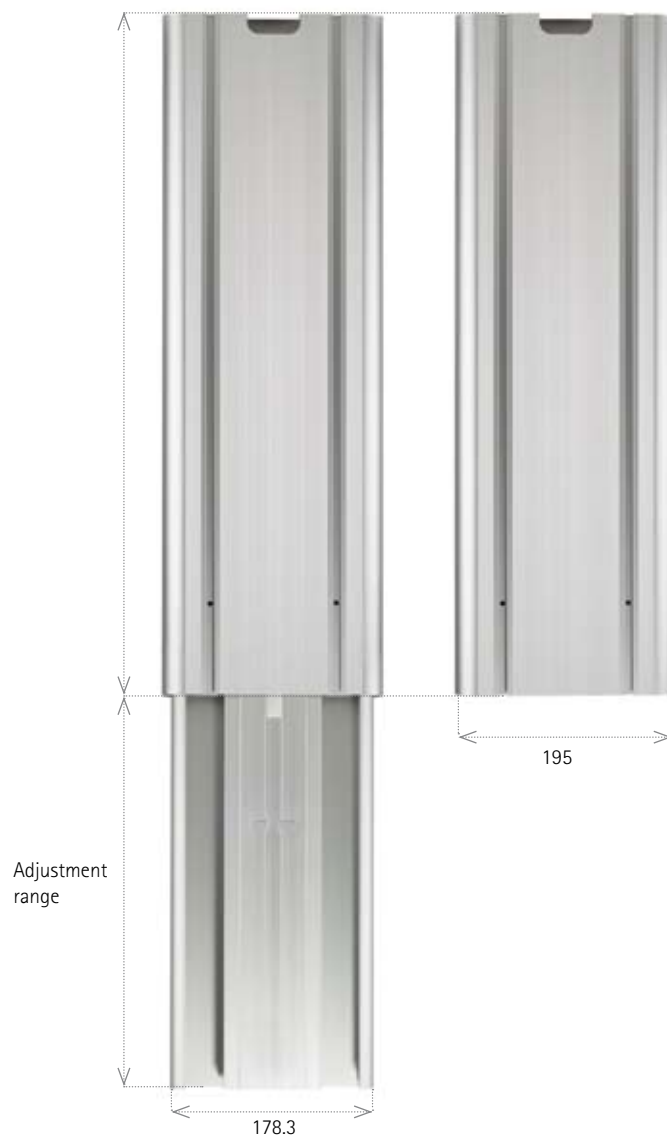

All dimensions in mm.