

ShenZhen Renice Technology Co., Ltd

X5A mSATA SATAIII SSD

Datasheet



V1.2

2019-12-25

Revision History

Revision	Description	Date
1.0	Formal Release	3/21/2017
1.1	Adding Secure Erase Function	4/18/2018
1.2	Performance optimization	25/12/2019

CATALOGUE

1. INTRODUCTION..... 3

 1.1 PRODUCT OVERVIEW.....3

 1.2 FEATURE..... 3

2. FUNCTIONAL BLOCK DIAGRAM.....4

3. PRODUCT SPECIFICATIONS.....4

 3.1 PHYSICAL SPECIFICATIONS..... 4

 3.2 HOST INTERFACE..... 5

 3.3 CAPACITY..... 6

4. INTERFACE DESCRIPTION.....6

 4.1 PIN ASSIGNMENT..... 6

 4.2 PIN DESCRIPTION..... 7

5. POWER SPECIFICATIONS..... 8

 5.1 POWER SPECIFICATION..... 8

 5.2 POWER SUPPLY VOLTAGE..... 8

 5.3 POWER CONSUMPTION (TYPICAL)..... 8

6. RELIABILITY SPECIFICATION..... 8

 6.1 ENVIRONMENT.....8

 6.2 WEAR-LEVELING.....9

 6.3 H/W ECC AND EDC FOR NAND FLASH.....9

 6.4 POWER FAILURE PROTECTION..... 9

 6.5 OVER VOLTAGE AND INRUSH CURRENT PROTECTION..... 9

 6.6 ENDURANCE.....9

 6.5 MTBF.....9

7. SECURE ERASE FUNCTION (OPTIONAL)..... 10

 7.1 TECHNICAL CONCEPT..... 10

8. SUPPORTED ATA COMMAND LIST.....11

9. SMART FEATURE SET..... 13

 9.1 SMART DATA STRUCTURE..... 14

 9.2 SMART ATTRIBUTES..... 15

10. ORDERING INFORMATION..... 16

11. PART NUMBER NAMING RULE..... 17

1. Introduction

1.1 Product Overview

Renice X5A mSATA SSD is a compact SSD with mini PCIe form factor and SATA 6.0Gb/s interface. It carries up to 512MB DDR3 Cache which delivers extremely high performance. X5A mSATA SSD conforms to the JEDEC MO-300B standard and supports Wide Operating Temperature, Power Failure Protection and over voltage protection. Its excellent stability and durability could meet the request of embedded equipments in harsh operating environment.

1.2 Feature

- **Standard Serial ATA:** SATA III, 6.0Gbps (Backward compatible with SATA 1.5 and 3.0Gbps)
- **Form factor:** mSATA 50.95mm X 30mm X 3.65mm (L x W x H)
- **Connector:** 52pin SATA-based mSATA pin out
- **Performance:**
 - Max Sequential Data Read/Write: 550MB/450MB/s
 - 4Kb Random Read/Write IOPS: 70,000 / 75,000
 - Access Time: <0.1ms
- **Capacities:** 64GB, 128GB, 256GB, 512GB, 1TB (MLC)
16GB, 32GB, 64GB, 128GB, 256GB (SLC)
- **Power Management:**
 - Input voltage: 3.3V (±5%)
 - Support Hot Plug/Removal Function
- **Temperature ranges:**
 - Operation: -40°C to +85°C
 - Storage: -50°C to +95°C
- **Intelligent features:**
 - Flash management algorithm: static and dynamic wear-leveling, bad block management algorithm
 - Supports dynamic power management and SMART (Self-Monitoring, Analysis and Reporting Technology)
 - Supports BCH ECC 66bits in 1KBytes
 - Support Power Failure Protection
 - Support over Voltage Protection
 - Support TRIM
 - Support NCQ
- **MTBF:** >3,000,000 Hours @25C

2. Functional Block Diagram

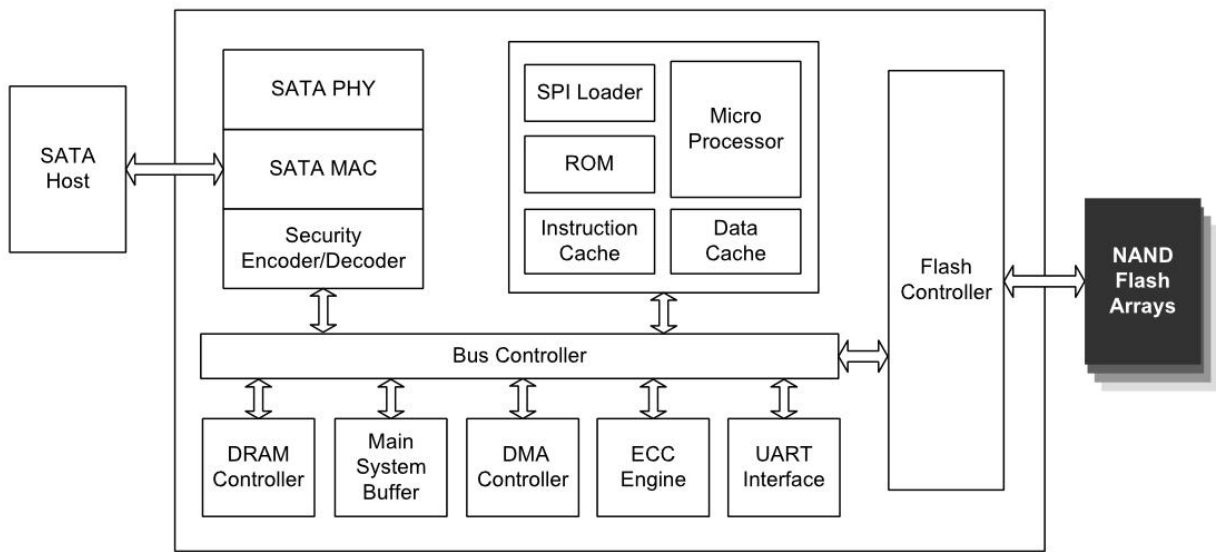

Figure 1: Renice X5A mSATA SATAIII SSD Block Diagram

3. Product Specifications

3.1 Physical Specifications

Table 1: Physical Specifications

Form Factor		mSATA
Dimensions	Length	50.95±0.25mm
	Width	30±0.25mm
	Height	3.65±0.25mm
Weight		<30g
Connector		52 pin

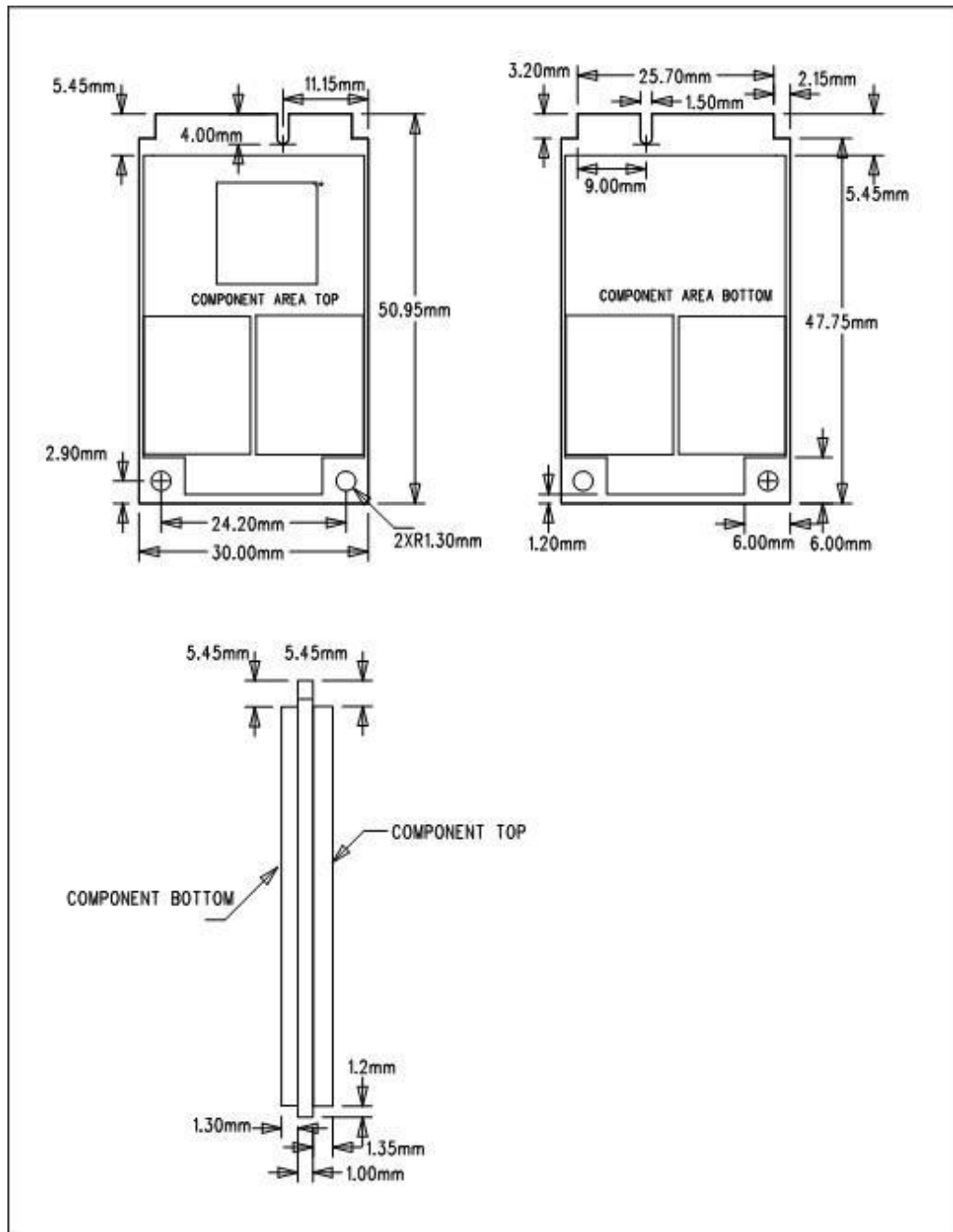

Figure 2: Renice X5A mSATA SATAIII SSD mechanical dimensions

3.2 Host Interface

- Industrial Standard SATA Revision 3.1 compliant
- Industrial Standard ATA/ATAPI-8 ACS-2 command compliant
- Supports SATA interface rate of 6Gb/s(backward compatible to 1.5Gb/s and 3Gb/s)
- Native Command Queuing (NCQ): up to 32 commands
- S.M.A.R.T. command transport (SCT) technology

SATA Device Sleep (DevSlp)
 Data Set Management command (TRIM)
 Supports 28bit and 48bit LBA mode commands

3.3 Capacity

Table 2: Capacity Specification

Parameter	LBA Counts (512Byte)	Over-provision (%)
16GB		6.25
32GB	61,865,984	6.25
64GB	123,731,968	6.25
128GB	247,463,936	6.25
256GB	494,927,872	6.25
512GB	989,855,744	6.25
1TB	1,979,711,488	6.25

4. Interface Description

4.1 Pin Assignment

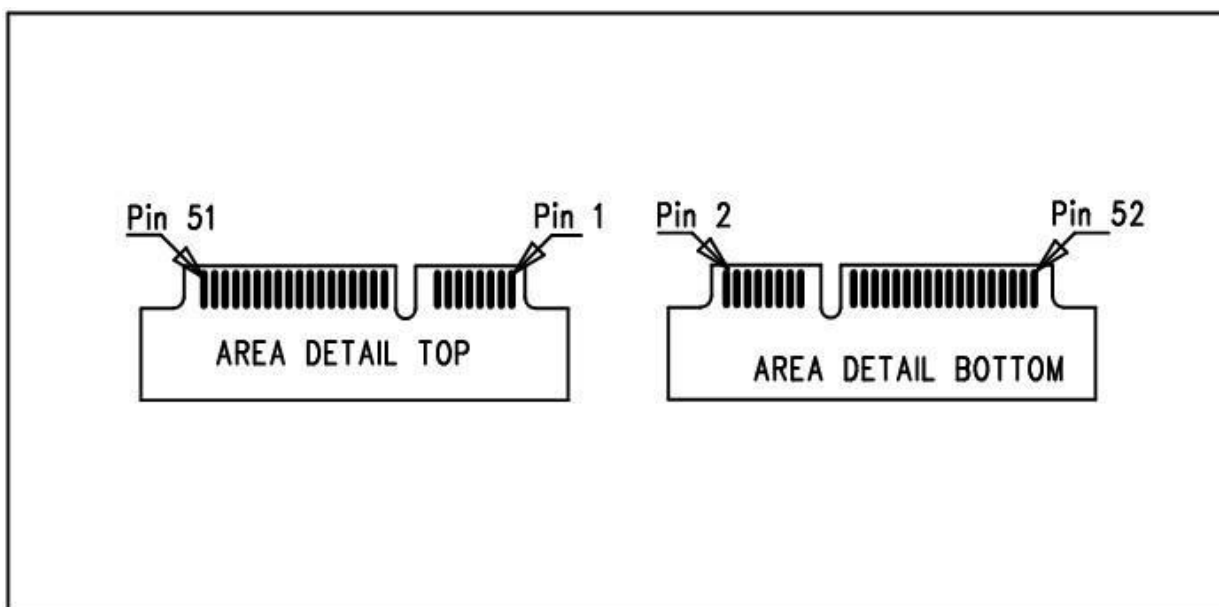

Figure 3: Pin Assignments

4.2 Pin Description

Table 3: Pin Assignment

Pin	Definitions	Pin	Definitions
P1	NC	P2	+3.3V
P3	NC	P4	GND
P5	NC	P6	NC
P7	NC	P8	NC
P9	GND	P10	NC
P11	NC	P12	NC
P13	NC	P14	NC
P15	GND	P16	NC
P17	NC	P18	GND
P19	NC	P20	NC
P21	GND	P22	NC
P23	SATA Differential TX+ based on SSD	P24	+3.3V
P25	SATA Differential TX- based on SSD	P26	GND
P27	GND	P28	NC
P29	GND	P30	NC
P31	SATA Differential RX- based on SSD	P32	NC
P33	SATA Differential RX+ based on SSD	P34	GND
P35	GND	P36	NC
P37	GND	P38	NC
P39	+3.3V	P40	GND
P41	+3.3V	P42	NC
P43	GND	P44	DevSlp
P45	Vendor	P46	NC
P47	Vendor	P48	NC
P49	DAS/DSS	P50	GND
P51	Presence Detection	P52	+3.3V

5. Power Specifications

5.1 Power Specification

Operating voltage: 3.3V (±5%)

5.2 Power Supply Voltage

1.2V for Core, 1.5V for DDR, 3.3V for NAND and 1.8V for NAND IO

5.3 Power Consumption (typical)

Operation (Read/Write) – 1.5W/ 6.5W

Idle – 0.6W

Standby – 0.45W

6. Reliability Specification

6.1 Environment

Table 4: Environmental Specifications

Item	Features	
Temperature	Operating	Industrial: -40°C~+85°C
Humidity	5-95%	
Vibration	10Hz-2000Hz, 16.4 G (X, Y, Z axis, 1 hour /axis)	
Shock	Peak Acceleration: 1,500 G, 0.5ms(Half-sine wave, ±X,±Y,±Z axis, 1 time/axis) Peak Acceleration: 50 G, 11ms(Half-sine wave, ±X,±Y,±Z axis, 3 times/axis)	

6.2 Wear-leveling

Renice X5A mSATA SSD support both static and dynamic wear-leveling, these two algorithms guarantee all type of flash memory at same level of erase cycles to improve lifetime limitation of NAND based storage.

6.3 H/W ECC and EDC for NAND Flash

BCH ECC 66 bits in 1024 bytes

6.4 Power Failure Protection

Renice X5A mSATA SSD adopts Voltage Detector Circuit to detect current voltage status, when current voltage is detected abnormal, the power failure protection function of X5A SSD will work to prevent data crash or drive corruption in case of sudden power failure.

6.5 Over voltage and inrush current protection

The over voltage and inrush current protection mechanism of Renice X5A MSATA SATAIII is designed to be a protect circuitry on Device Power In. Once the current or voltage is exceeded, it will be pull down to the normal value in very short time to protect the drive.

6.6 Endurance

Write endurance: >12 years @ 100GB write/ day (256GB MLC)

Read endurance: unlimited

6.5 MTBF

MTBF (Mean Time between Failures) of Renice X5A mSATA SSD >3,000,000 hours @25C

7. Secure Erase Function (Optional)

Renice X5A mATA SSD reserves GPIO for emergency data erase. External wires connected JP3 to GND for above 3 seconds to trigger Secure Erase. The process of erase will not stop till finish, even a sudden power cut in the process, it will continue once power is restored.

7.1 Technical Concept

The SE command is transmitted to controller chip from the GPIO of the IO expanding chip, SE could be triggered by pulling GPIO down for 3 seconds whether through HW (i.e. external switch or button) or SW, the controller will then send Delete Command to NAND Flash to start SE.

a. Trigger Time: 0~3 seconds

Controller will take it as spurious triggering and no SE command will be sent.

b. Trigger Time: 3~10 seconds

All data on board will be deleted and data on 00 pattern will be written in.

8. Supported ATA Command List

Table 5: Support ATA Command Lists

Command	Code	Protocol
General Feature Set		
Execute Device Diagnostic	90h	Execute device diagnostic
Flush Cache	E7h	Non-data
Identify Device	ECh	PIO data-in
Initialize Drive Parameters	91h	Non-data
Read DMA	C8h	DMA
Read Log Ext	2Fh	PIO data-in
Read Multiple	C4h	PIO data-in
Read Sector(s)	20h	PIO data-in
Read Verify Sector(s)	40h or 41h	Non-data
Set Feature	EFh	Non-data
Set Multiple Mode	C6h	Non-data
Write DMA	CAh	DMA
Write Multiple	C5h	PIO data-out
Write Sector(s)	30h	PIO data-out
NOP	00h	Non-data
Read Buffer	E4h	PIO data-in
Write Buffer	E8h	PIO data-out
Power Management Feature Set		
Check Power Mode	E5h or 98h	Non-data
Idle	E3h or 97h	Non-data
Idle Immediate	E1h or 95h	Non-data
Sleep	E6h or 99h	Non-data
Standby	E2h or 96h	Non-data
Standby Immediate	E0h or 94h	Non-data
Security Mode Feature Set		
Security Set Password	F1h	PIO data-out
Security Unlock	F2h	PIO data-out
Security Erase Prepare	F3h	Non-data
Security Erase Unit	F4h	PIO data-out
Security Freeze Lock	F5h	Non-data
Security Disable Password	F6h	PIO data-out

SMART Disable Operations	B0h	Non-data
SMART Enable/Disable Autosave	B0h	Non-data
SMART Enable Operations	B0h	Non-data
SMART Execute OFF-LINE Immediate	B0h	Non-data
SMART Read Log	B0h	PIO data-in
SMART Read Data	B0h	PIO data-in
SMART Read Threshold	B0h	PIO data-in
SMART Return Status	B0h	Non-data
SMART Save Attribute Values	B0h	Non-data
SMART Write Log	B0h	PIO data-out
Host Protected Area Feature Set		
Read Native Max Address	F8h	Non-data
Set Max Address	F9h	Non-data
Set Max Set Password	F9h	PIO data-out
Set Max Lock	F9h	Non-data
Set Max Freeze Lock	F9h	Non-data
Set Max Unlock	F9h	PIO data-out
48-bit Address Feature Set		
Flush Cache Ext	EAh	Non-data
Read Sector(s) Ext	24h	PIO data-in
Read DMA Ext	25h	DMA
Read Multiple Ext	29h	PIO data-in
Read Native Max Address Ext	27h	Non-data
Read Verify Sector(s) Ext	42h	Non-data
Set Max Address Ext	37h	Non-data
Write DMA Ext	35h	DMA
Write Multiple Ext	39h	PIO data-out
Write Sector(s) Ext	34h	PIO data-out
NCQ Feature Set		
Read FPDMA Queued	60h	DMA Queued
Write FPDMA Queued	61h	DMA Queued
Others		
Data Set Management	06h	DMA
Seek	70h	Non-data

9. SMART Feature Set

The Renice X5A supports the SMART command set and defines some vendor-specific data to report spare/bad block numbers in each memory management unit.

Table 6: SMART Feature Register Values

Command Name	Command Code
SMART READ DATA	D0h
SMART Read Attribute Threshold	D1h
SMART ENABLE/DISABLE ATTRIBUTE AUTOSAVE	D2h
SMART SAVE ATTRIBUTE VALUES	D3h
SMART EXECUTE OFF-LINE IMMEDIATE	D4h
SMART READ LOG	D5h
SMART WRITE LOG	D6h
SMART ENABLE OPERATIONS	D8h
SMART DISABLE OPERATIONS	D9h
SMART RETURN STATUS	DAh

9.1 SMART Data Structure

The following 512bytes make up the device SMART data structure. Users can obtain the data using the “Read Data” command (D0h).

Table 7: SMART Data Structure

Byte	F / V	Description
0 - 1	X	Revision code
2 - 361	X	Vendor specific (see 4.3.2)
362	V	Off-line data collection status
363	X	Self-test execution status byte
364 - 365	V	Total time in seconds to complete off-line data collection activity
366	X	Vendor specific
367	F	Off-line data collection capability
368 - 369	F	SMART capability
370	F	Error logging capability <ul style="list-style-type: none"> • 7-1 Reserved • 0 1 = Device error logging supported
371	X	Vendor specific
372	F	Short self-test routine recommended polling time (in minutes)
373	F	Extended self-test routine recommended polling time (in minutes)
374	F	Conveyance self-test routine recommended polling time (in minutes)
375 - 385	R	Reserved
386 - 395	F	Firmware version/date code
396 - 399	F	Reserved
400 - 405	F	'SM2246'
406 - 510	X	Vendor specific
511	V	Data structure checksum

Notes:

1. F = content (byte) is fixed and does not change.
2. V = content (byte) is variable and may change depending on the state of the device or the commands executed by the device.
3. X = content (byte) is vendor specific and may be fixed or variable.
4. R = content (byte) is reserved and shall be zero.

9.2 SMART Attributes

The following table defines the vendor specific data in byte 2 to 361 of the 512byte SMART data.

Table 8: SMART Data Vendor-specific Attributes

Attribute ID (hex)	Raw Attribute Value							Attribute Name
	MSB	00	00	00	00	00	00	
01	MSB	00	00	00	00	00	00	Read error rate
05	LSB	MSB	00	00	00	00	00	Reallocated sectors count
09	LSB			MSB	00	00	00	Power-on hours
0C	LSB			MSB	00	00	00	Power cycle count
A0	LSB			MSB	00	00	00	Uncorrectable sector count when read/write
A1	LSB	MSB	00	00	00	00	00	Number of valid spare block
A3	LSB	MSB	00	00	00	00	00	Number of initial invalid block
A4	LSB			MSB	00	00	00	Total erase count
A5	LSB			MSB	00	00	00	Maximum erase count
A6	LSB			MSB	00	00	00	Minimum erase count
A7	LSB			MSB	00	00	00	Average erase count
A8	LSB			MSB	00	00	00	Max erase count of spec
A9	LSB			MSB	00	00	00	Remain Life (percentage)
AF	LSB			MSB	00	00	00	Program fail count in worst die
B0	LSB	MSB	00	00	00	00	00	Erase fail count in worst die
B1	LSB			MSB	00	00	00	Total wearlevel count
B2	LSB	MSB	00	00	00	00	00	Runtime invalid block count
B5	LSB			MSB	00	00	00	Total program fail count
B6	LSB	MSB	00	00	00	00	00	Total erase fail count
BB	LSB			MSB	00	00	00	Uncorrectable error count
C0	LSB	MSB	00	00	00	00	00	Power-off retract count
C2	MSB	00	00	00	00	00	00	Controlled temperature
C3	LSB			MSB	00	00	00	Hardware ECC recovered
C4	LSB			MSB	00	00	00	Reallocation event count
C6	LSB			MSB	00	00	00	Uncorrectable error count off-line
C7	LSB	MSB	00	00	00	00	00	UltraDMA CRC error count
E1	LSB						MSB	Total LBAs written (each write unit = 32MB)
E8	LSB	MSB	00	00	00	00	00	Available reserved space
F1	LSB						MSB	Total LBAs written (each write unit = 32MB)
F2	LSB						MSB	Total LBAs read (each read unit = 32MB)

10. Ordering Information

Table 9: Valid Combinations

Part Number	Description
RIM064-SX5AM	X5A MSATA SATAIII 64GB MLC Industrial SSD
RIM128-SX5AM	X5A MSATA SATAIII 128GB MLC Industrial SSD
RIM256-SX5AM	X5A MSATA SATAIII 256GB MLC Industrial SSD
RIM512-SX5AM	X5A MSATA SATAIII 512GB MLC Industrial SSD
RIM01T-SX5AM	X5A MSATA SATAIII 1TB MLC Industrial SSD
RIS016-SX5AM	X5A MSATA SATAIII 16GB SLC Industrial SSD
RIS032-SX5AM	X5A MSATA SATAIII 32GB SLC Industrial SSD
RIS064-SX5AM	X5A MSATA SATAIII 64GB SLC Industrial SSD
RIS128-SX5AM	X5A MSATA SATAIII 128GB SLC Industrial SSD
RIS256-SX5AM	X5A MSATA SATAIII 256GB SLC Industrial SSD

11. Part Number Naming Rule

