



The Loewe® GK series



Torque

Resists axial motion
Bore diameter up to 50 mm
Torque (T_{KN}) 44 Nm to 220 Nm



Linear

Precise transmission of
push-pull loads
Bore diameter up to 50 mm
Thread diameter up to size M27

Loewe® GK

Loewe® GK: The axially fixed Loewe® GK is designed to offer generous angular and radial misalignment compensation together with high axial stiffness.

Loewe® GK is designed to resist axial motion and for precise transmission of pure linear motion for use in cylinder systems.

Torque

The Loewe® GK series for applications that on the one hand, must transmit torque and on the other, must transmit push-pull loads. By design, the Loewe® GK Torque series accommodates generous angular and parallel misalignments, also under axial force.

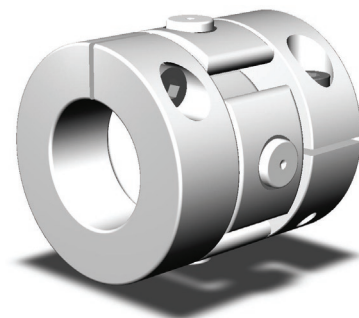
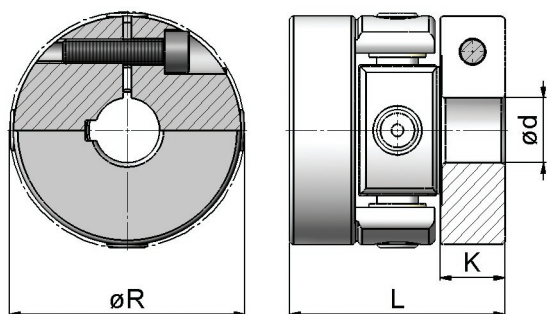

	$\varnothing R$ (mm)	L (mm)	$\varnothing d_{max}$ (mm)	K (mm)	m (kg)	T_{KN} (Nm)	TK_{max} (Nm)	ΔK_c (mm)	ΔK_w (°)	n_{max} (1/min)
GK 27	33	36	11	10,5	0,05	4	9	1	3	4.000
GK 35	41	37	16	12,5	0,09	7	15	1,5	3	3.500
GK 56	61	53	30	15	0,3	33	95	2	3	2.500
GK 75	84	83	40	25	0,8	90	240	2	3	2.500
GK 100	109	97	50	27,5	1,8	220	550	2,5	3	1.500

Order Example 1: GK 27 $\varnothing 6$ $\varnothing 8$ Order Example 2: GK 56 $\varnothing 20$ $\varnothing 20N$

GK 56	$\varnothing 20$ $\varnothing 20N$
Type Loewe® GK Torque GK 56	bore diameters

To ensure the correct selection of the Loewe® GK please use our selection procedure and legend area to download the required information.

The life cycle of couplings will be determined by the existing loads and misalignments. The influences of torques and misalignment are described as follows.

1. The maximum torque $T_{K \max}$ may not be exceeded while operating. The design torque is determined from the continuous torque rating of the coupling in due consideration with the height of the misalignment capacity. The transferable torque will decrease with rising speed (rpm) or rising misalignment.
2. The radial misalignment K_r should not be exceeded. With continuous torques increasing misalignment keeps to an increased linear movement in the bearings and consequently to an increasing wear. Please choose a larger size of coupling with a higher torque capacity if applicable.
3. The angular misalignment K_w should not be exceeded. With continuous torques increasing misalignment keeps to an increased lagging in the bearings and consequently to an increasing wear. Please choose a larger size of coupling with a higher torque capacity if applicable.

Legend

Performance

T_{KN}	continuous torque rating of the coupling (Nm)
$T_{K \max}$	maximum torque capacity of the coupling (Nm)
F_a	maximum axial loads (N)
n_{\max}	maximum speed of the coupling (1/min)
ΔK_r	maximum radial misalignment capacity (mm)
ΔK_a	maximum axial misalignment capacity (mm)
ΔK_w	maximum angular misalignment capacity (°)

Dimension

$\varnothing R$	swing diameter (mm)
L	coupling length (mm)
K	clamp hub length (mm)
$\varnothing d_{\max}$	maximum bore diameter (mm)
$\varnothing d_{\min}$	minimum bore diameter (mm)
m	weight of the coupling (kg)