

---

# Mannington Apex Update & West Coast Adura 3-Tier Update

ASSEMBLY INSTRUCTIONS

June 2021

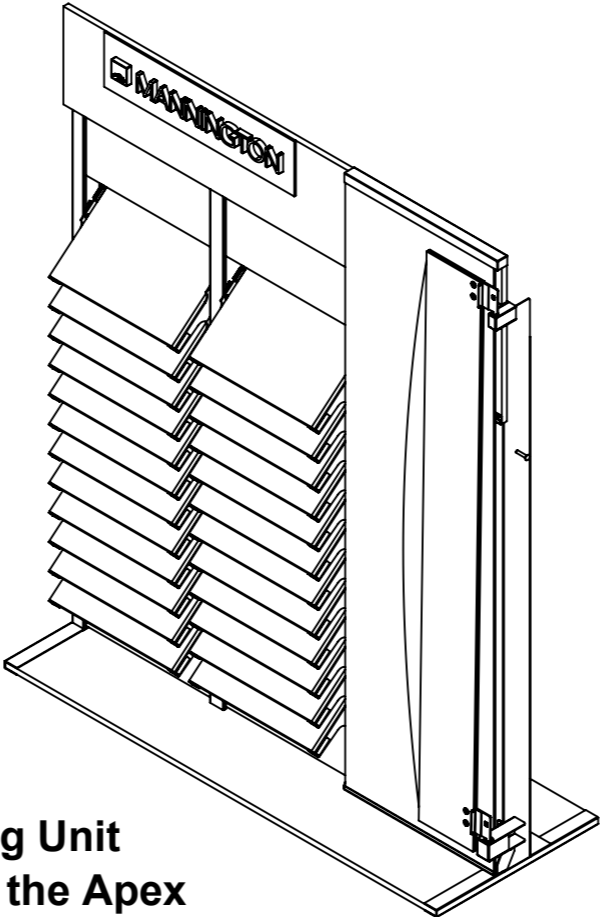
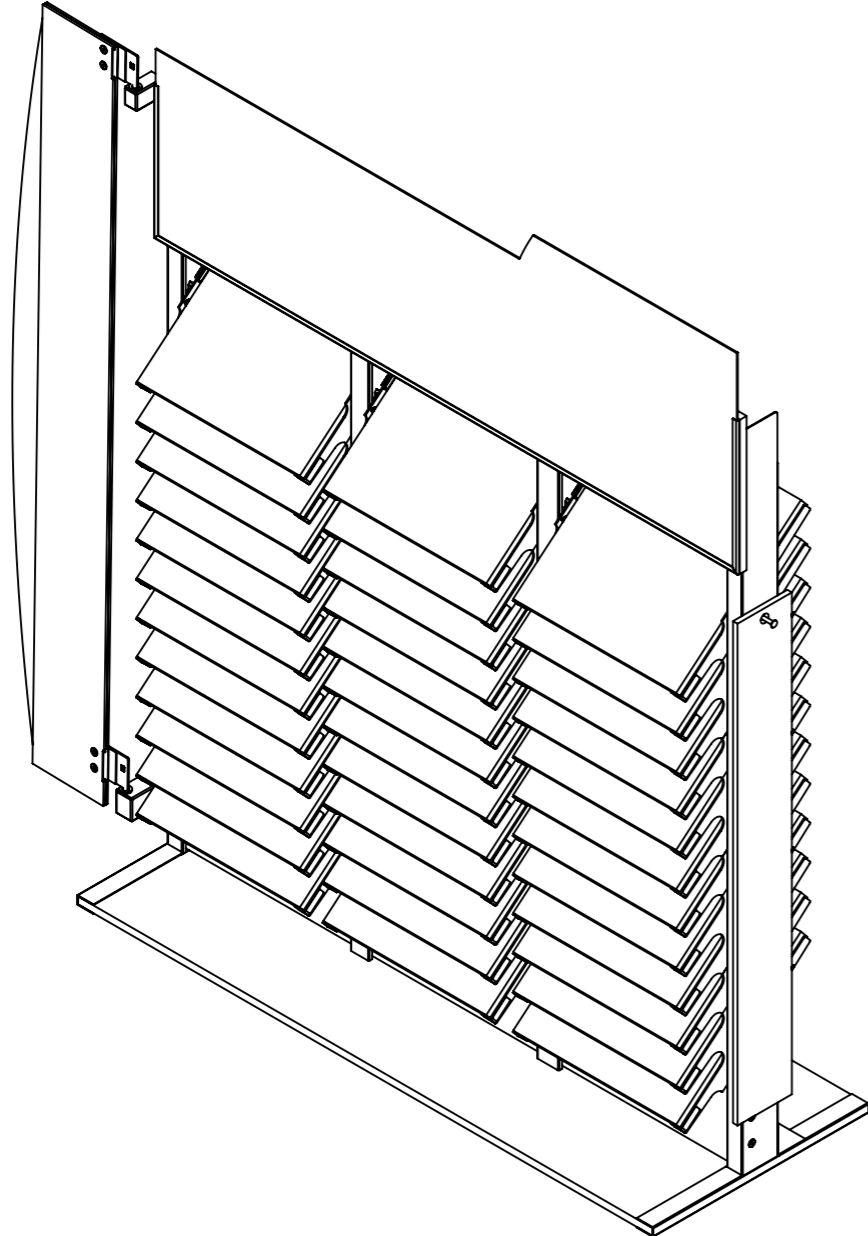

Existing Unit  
Before the Apex  
update

**Mannington - 2019 Apex Update**

February, 2019

<u>Order Code</u>	<u>SAP</u>	<b>Cartons in BOLD</b> <u>Description</u>	<u>Qty</u>
<b>800905</b>	<b>422603</b>	<b>Apex 2019 Header Update Frame</b>	
801686	422613	Header Frame - assembled	1
n/a	n/a	Instruction Sheet	1
<b>800906</b>	<b>422606</b>	<b>Apex 2019 Top Pivot Bracket</b>	
801687	422614	Top Pivot Bracket (new)	1
801688	422615	Hardware Bag	1
<b>800909</b>	<b>422612</b>	<b>Apex 2019 Header Update graphic</b>	
n/a	n/a	Header update graphic 2019	1
<b>900395</b>	<b>348609</b>	<b>Adura Max Rails (4 sets)</b>	
803170	313425	AMV Triple Rail Set (L+R) black	4

**Mannington - 2021 West Coast 3-Tier Update**

April, 2021

<u>Order Code</u>	<u>SAP</u>	<b>Cartons in BOLD</b> <u>Description</u>	<u>Qty</u>
<b>800905</b>	<b>422603</b>	<b>Apex 2019 Header Update Frame</b>	
801686	422613	Header Frame - assembled	1
n/a	n/a	Instruction Sheet	1
<b>806154</b>	<b>483469</b>	<b>West Coast 3-Tier Graphic Update</b>	
n/a	n/a	Side Graphic	1
n/a	n/a	Header Graphic	1
n/a	n/a	Instruction Sheet	1
<b>800022</b>	<b>393393</b>	<b>Max Value Graphic Update - Bracket/Hardware</b>	
800092	401103	Top Bracket	1
800093	401104	Bottom Bracket	1
800196	401105	Hardware Bag	1
n/a	n/a	Instruction sheet	1

**NOTE: For the 3-Tier Update, you only need to follow steps 2B, 3 & 5 of this instruction sheet. The other cartons will have the remainder of instructions.**

# RECOMMENDED TOOLS

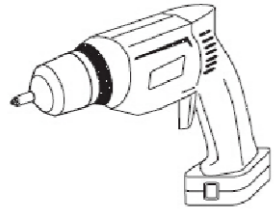

CORDLESS  
POWER DRILL



PHILLIPS HEAD  
SCREWDRIVER

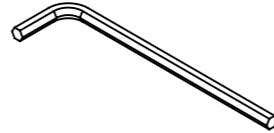

4mm HEX KEY

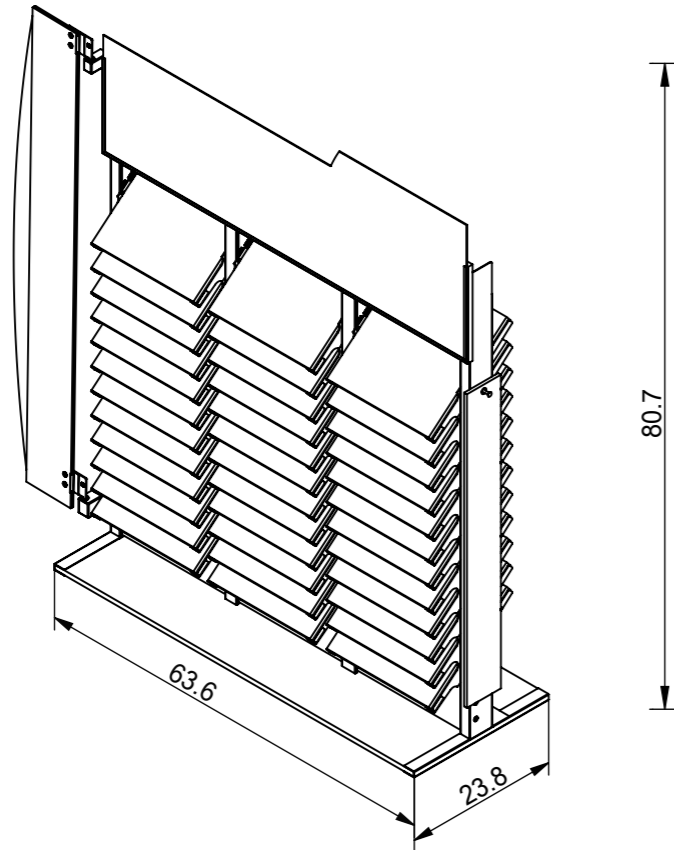

Be sure to provide a minimum of 63.6" to install this display.  
Display Foot Print: 63.6" x 23.8" x 80.7"



**HAND TIGHTEN ALL FASTENERS  
DURING ASSEMBLY.**

**WHEN ASSEMBLY IS COMPLETED  
USE APPROPRIATE TOOLS TO SECURE  
ALL FASTENERS PERMANENTLY.**

# SAFETY GUIDELINES

**Failure to follow the assembly instructions  
could result in damage or injury.**

**Install in a level and stable location. If not on a  
level surface please level before installation.**

**Assemble display in the area it will occupy.  
Never attempt to move display after loading.**

**When using any power tools, always use  
eye protection.**



**Do not work on this display with product in it.  
Unload display before relocating unit.  
Failure to do this may result in damage or injury.**



**For proper installation and safety follow all steps  
in sequential order.**

**Two people required to set up this display.**



For customer assistance: [POPServices@artguildinc.com](mailto:POPServices@artguildinc.com)  
or call 877.233.7962 and ask for Mannington representative.

# PARTS

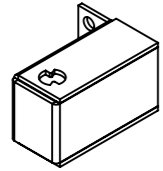

TOP PIVOT  
BRACKET  
1x

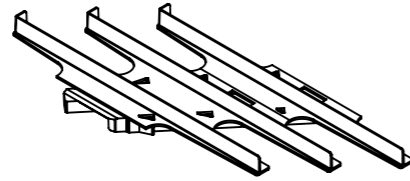

LEFT RAIL  
4x

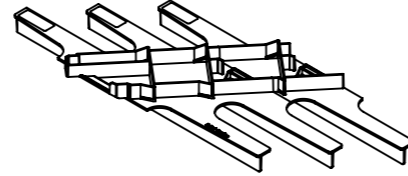

RIGHT RAIL  
4x

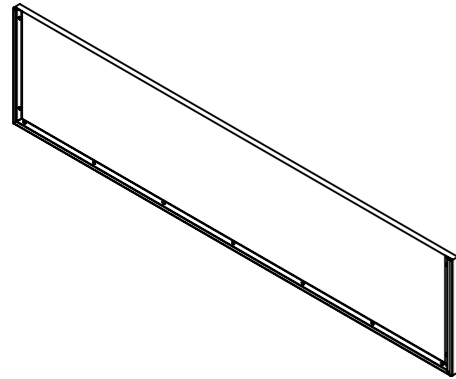

HEADER FRAME  
ASSEMBLED  
1x

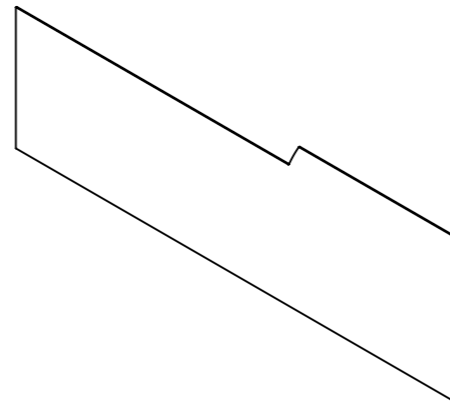

HEADER GRAPHIC  
1x

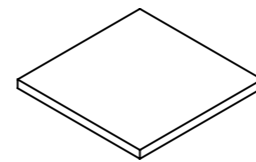

SAMPLE  
12x

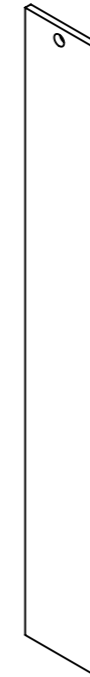

PLANK SAMPLE  
1x



For customer assistance: [POPServices@artguildinc.com](mailto:POPServices@artguildinc.com)  
or call 877.233.7962 and ask for Mannington representative.

---

# HARDWARE

---

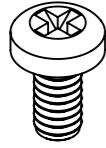

.5in BOLT  
**10x**

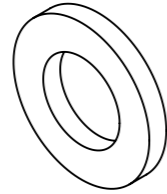

WASHER  
**2x**

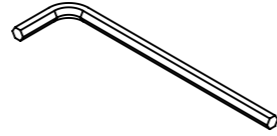

4mm HEX KEY  
**1x**



For customer assistance: [POPServices@artguildinc.com](mailto:POPServices@artguildinc.com)  
or call **877.233.7962** and ask for Mannington representative.

---

# Step 1

**A**

**NOTE:**  
Remove the swinging graphic  
(keeping hardware to use on the other  
side).

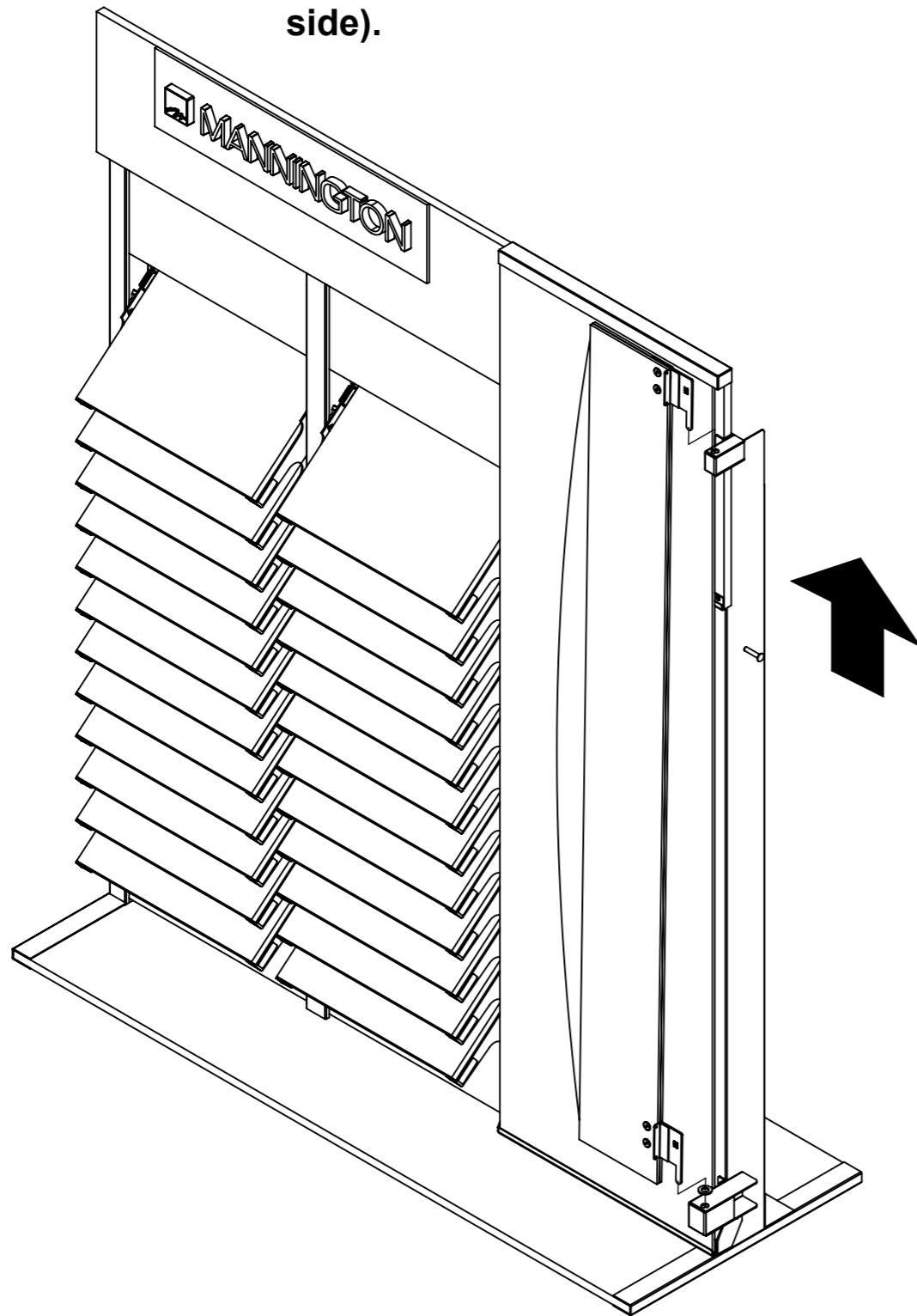

**B**

**NOTE:**  
Remove the top and bottom pivot.  
Keep the bottom pivot and screws  
for re-assembly in Step 6. When  
the bottom pivot is removed,  
re-install the wood screw into the  
display.

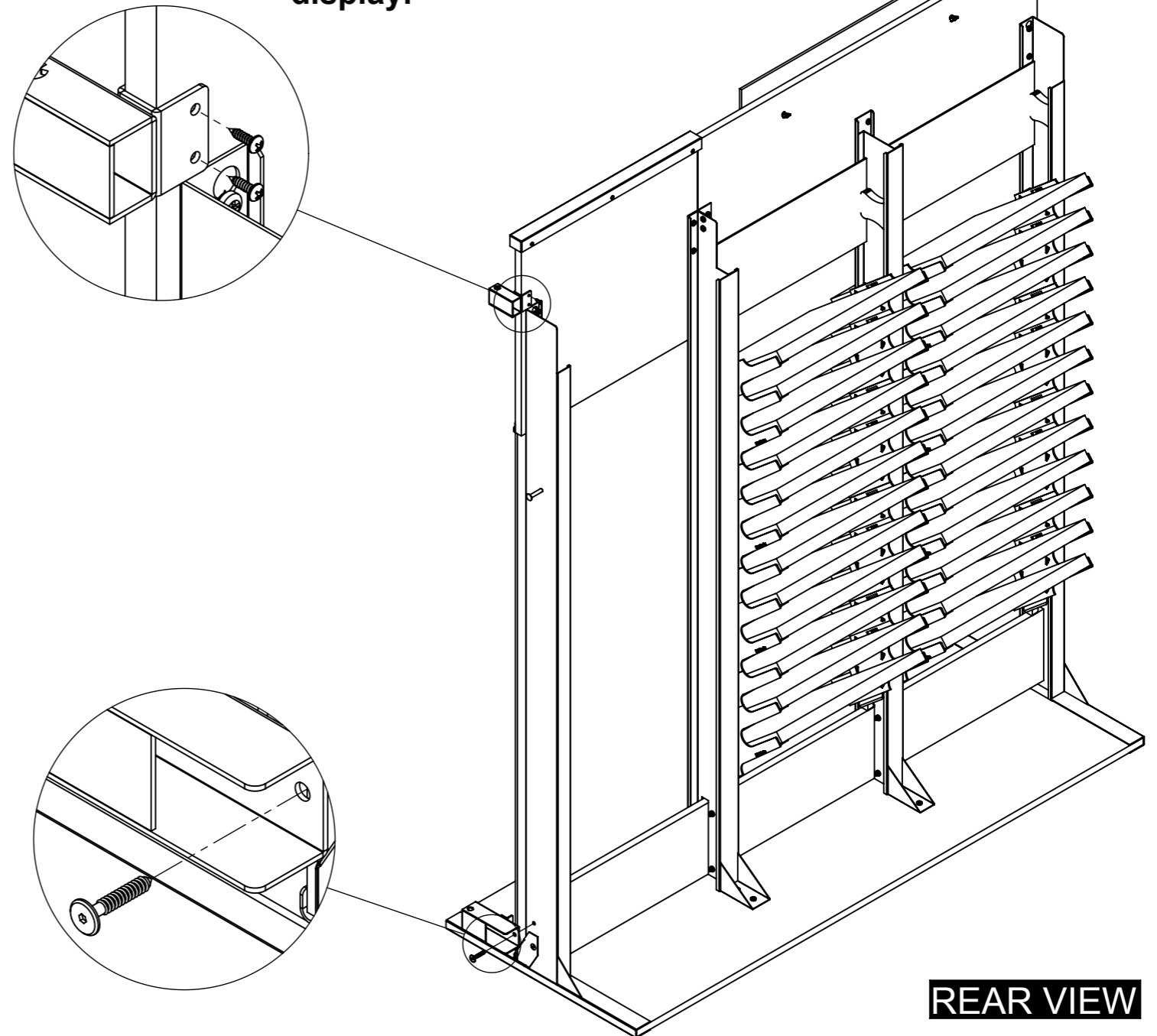

# Step 2

**A** NOTE:  
Remove the full sized graphic.

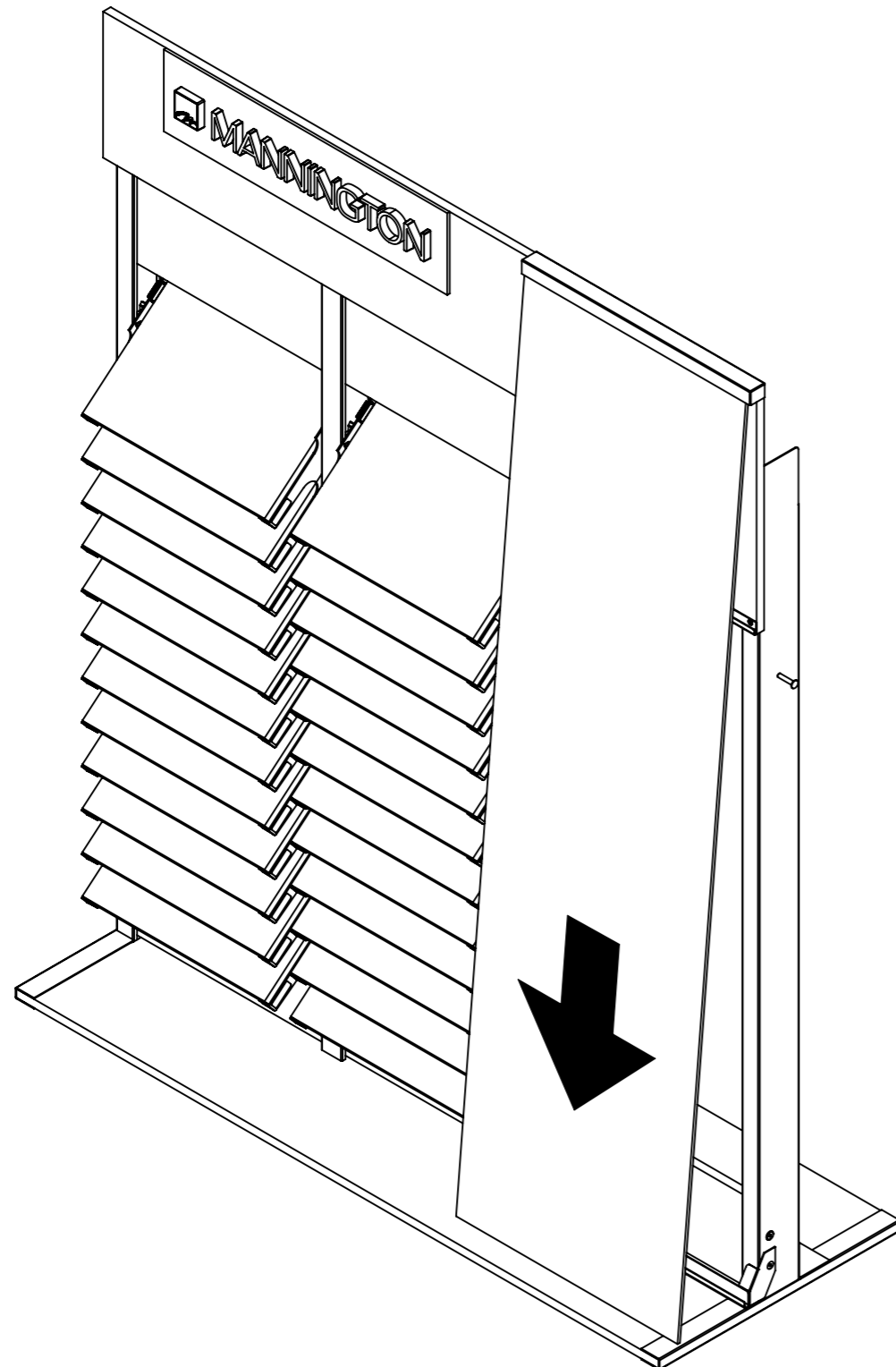

**B** NOTE:  
Remove the Right Header panel.

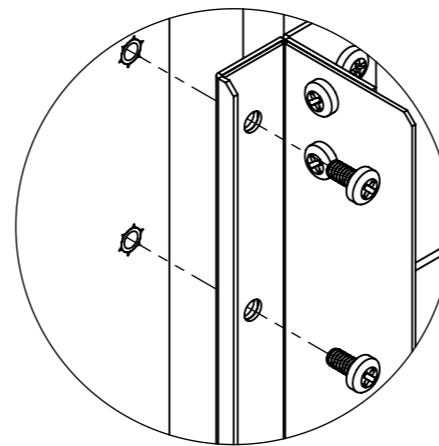

NOTE:  
Remove the screw to  
remove the component,  
then replace the screw.

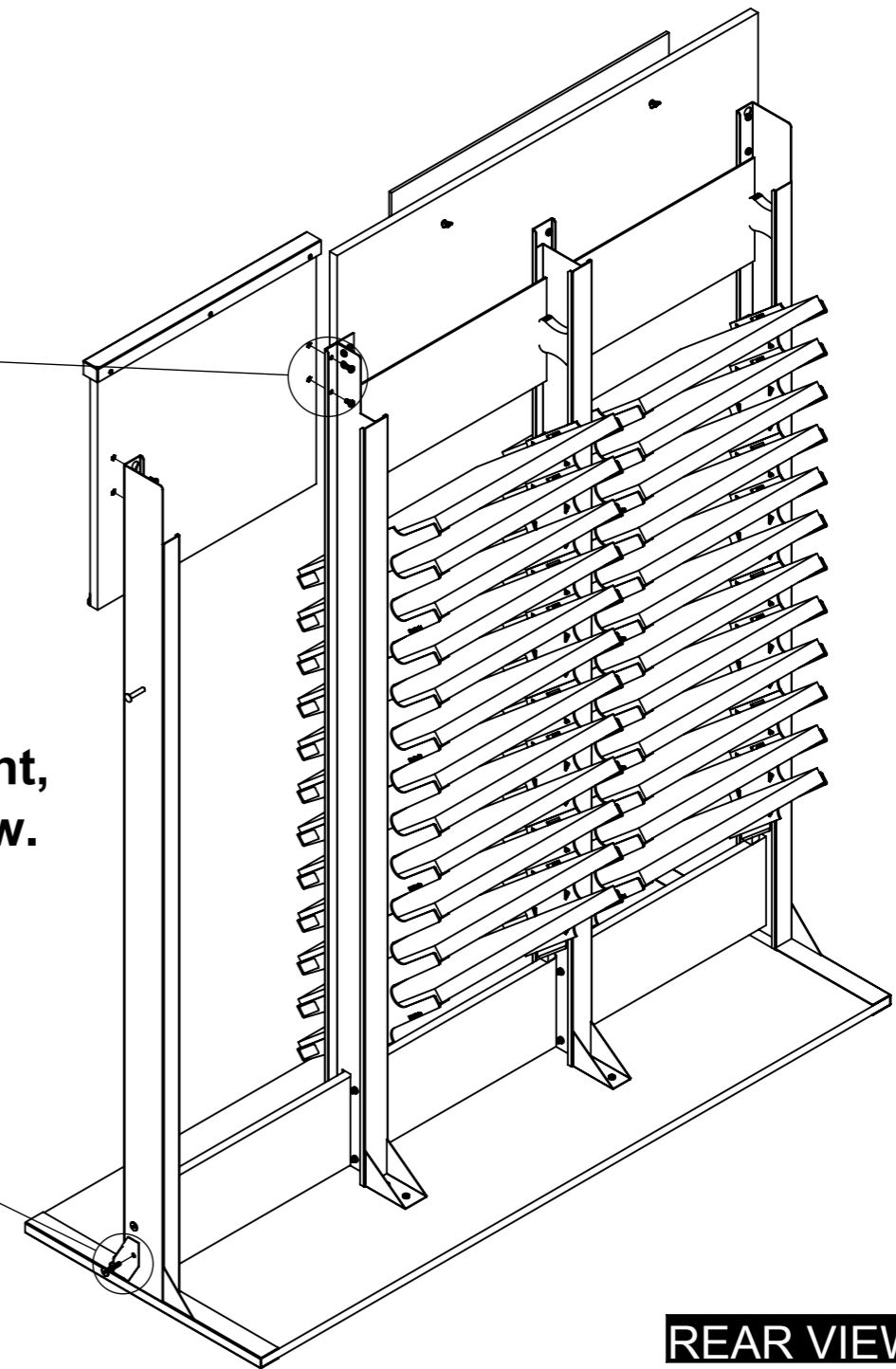
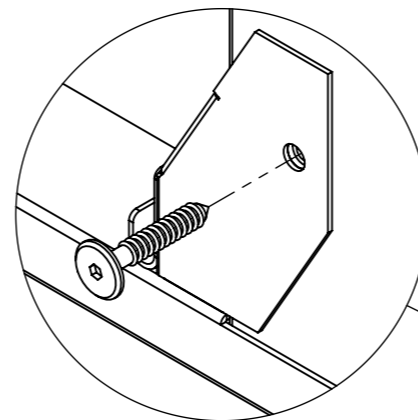

**REAR VIEW**

# Step 3

**A**

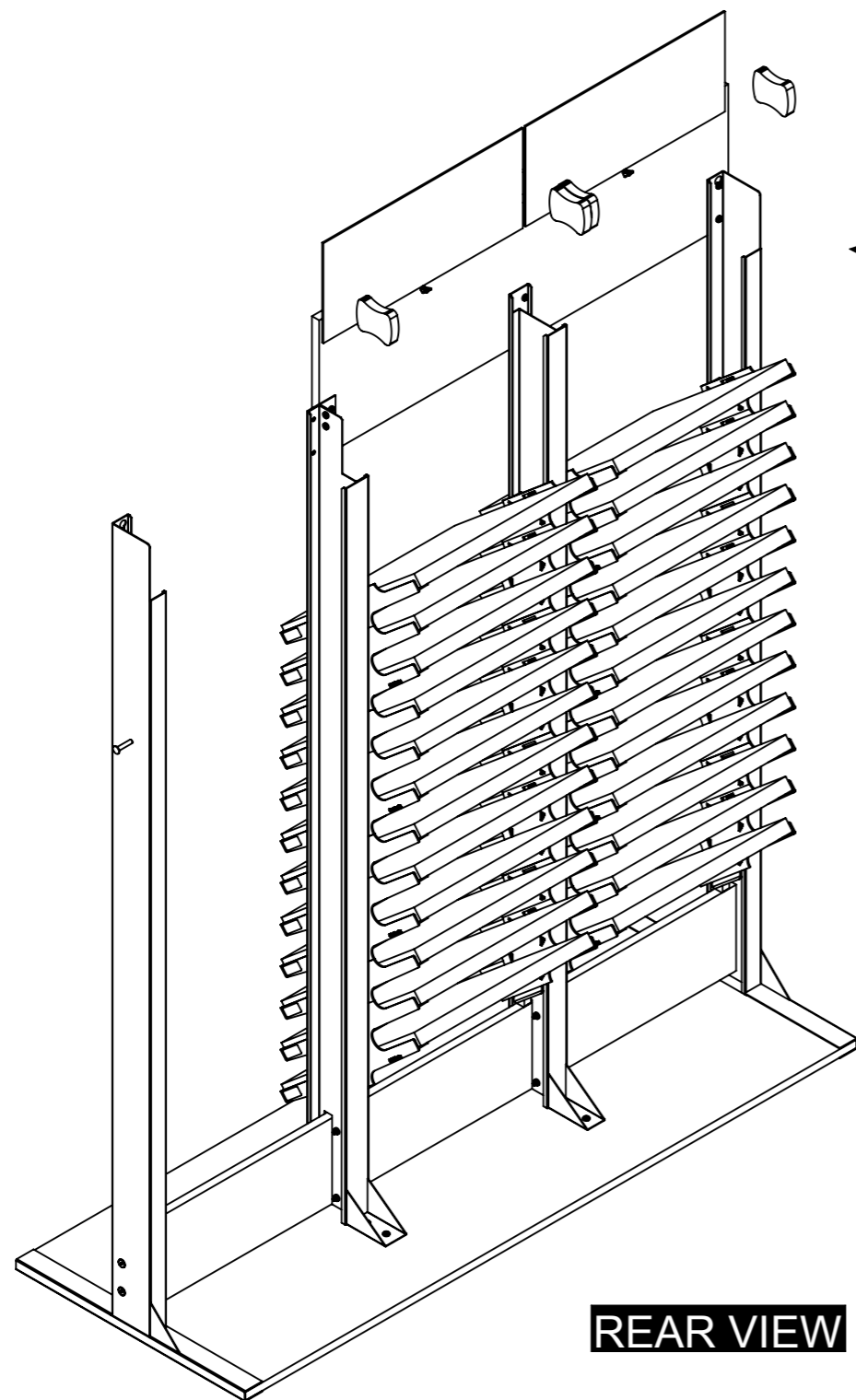

**REAR VIEW**

**B**

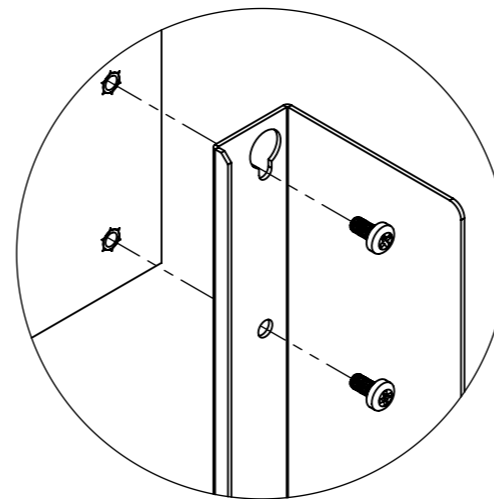

**NOTE:**  
Disassemble the graphic and header from the old display for next step.

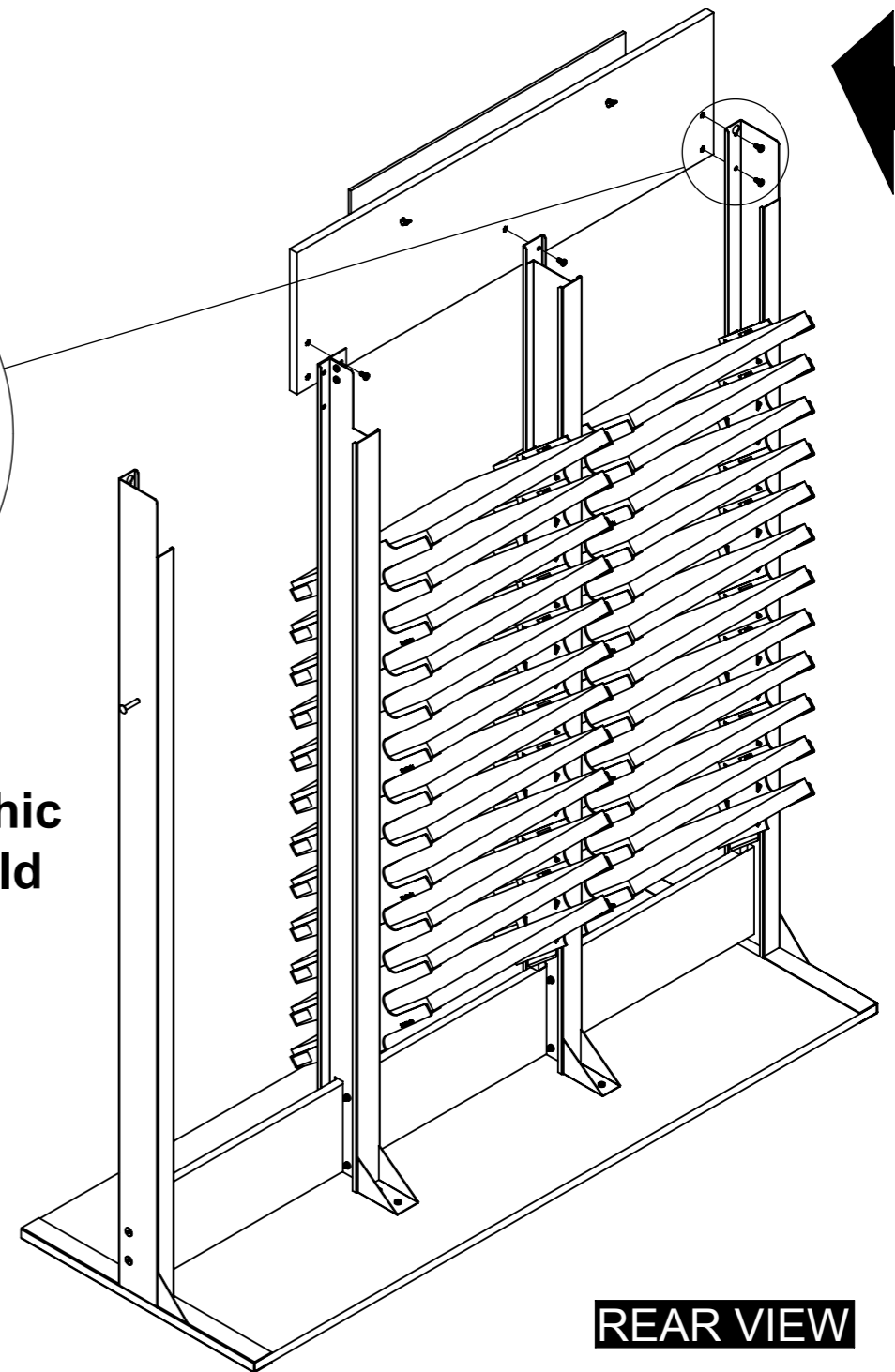

**REAR VIEW**



# Step 4

**Note:**

**Add the 4 left rails and the 4 right rails into the right side of the display.**

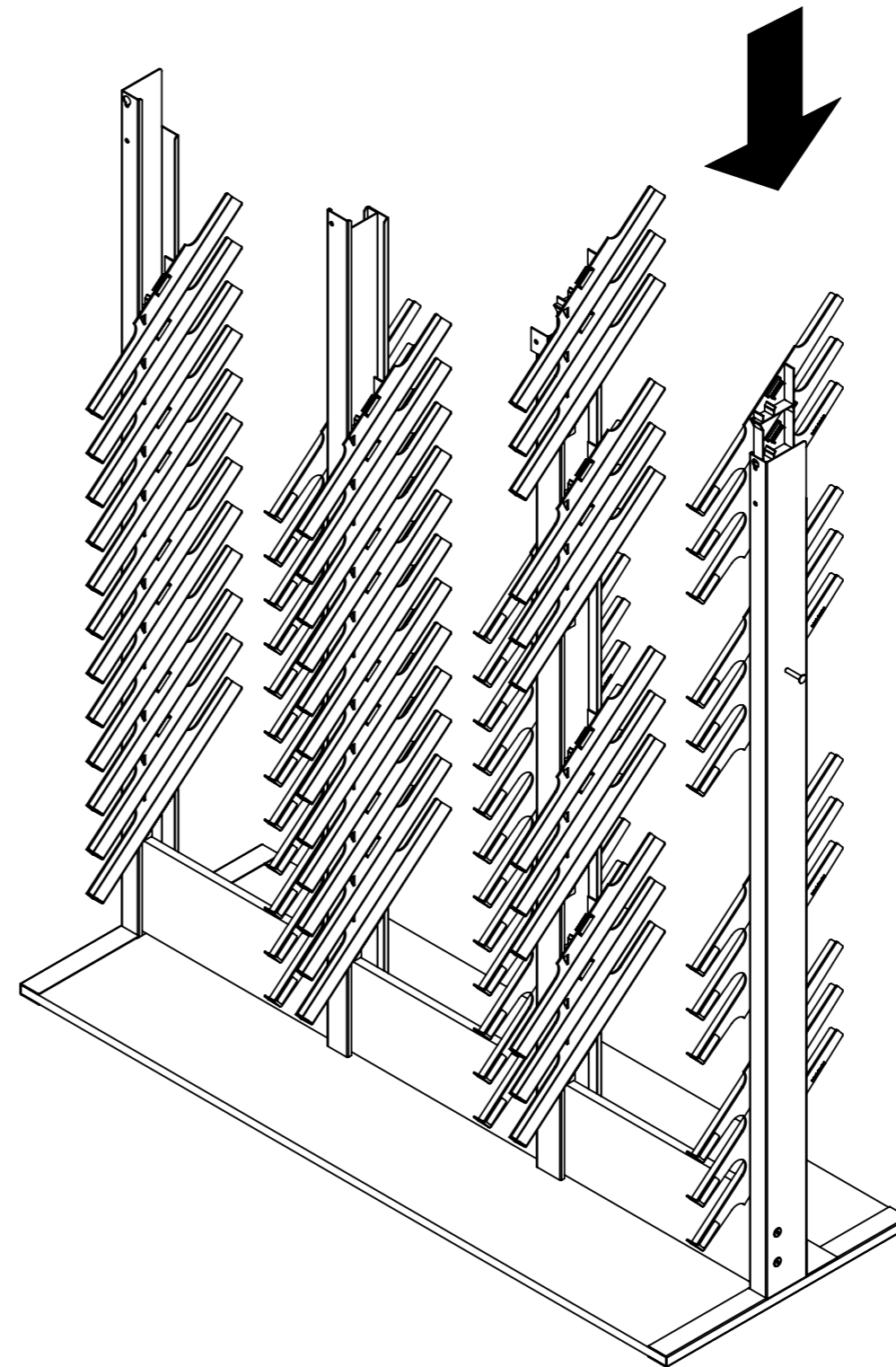
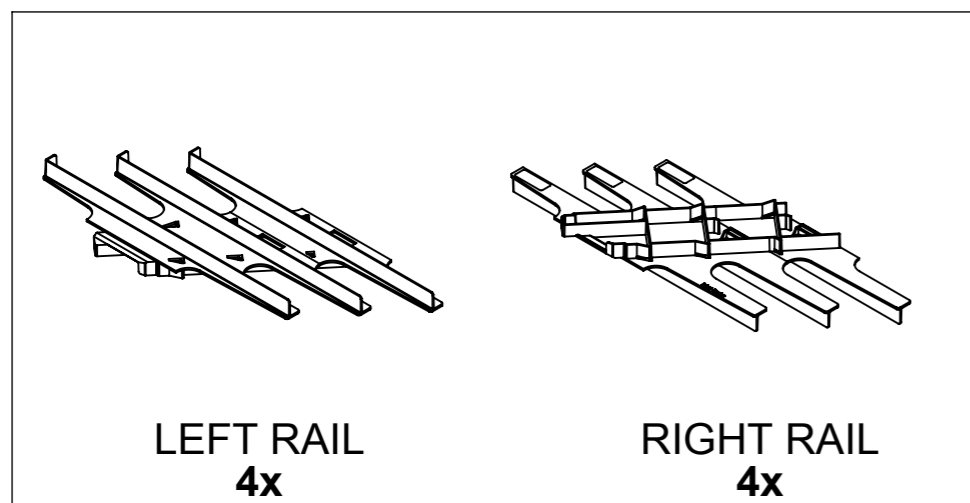

# Step 5

**Note:**

To make installation of the Header Frame easier. Attach the left and right top screw with about 1/8" exposed. You can hang the header frame onto the display using the key hole slot in the legs. Then attach the hardware from the back. Tighten all screws.

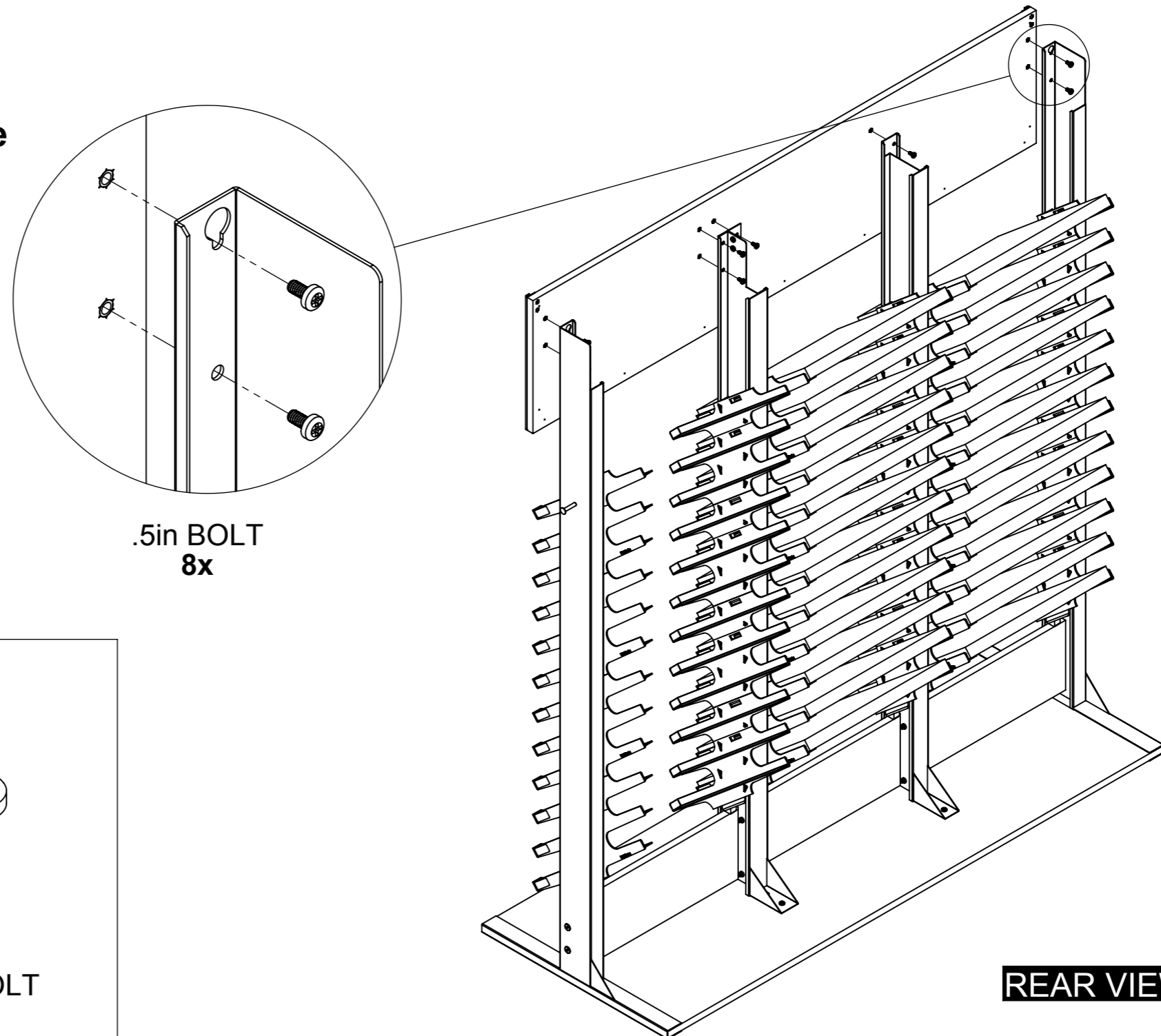

.5in BOLT  
8x

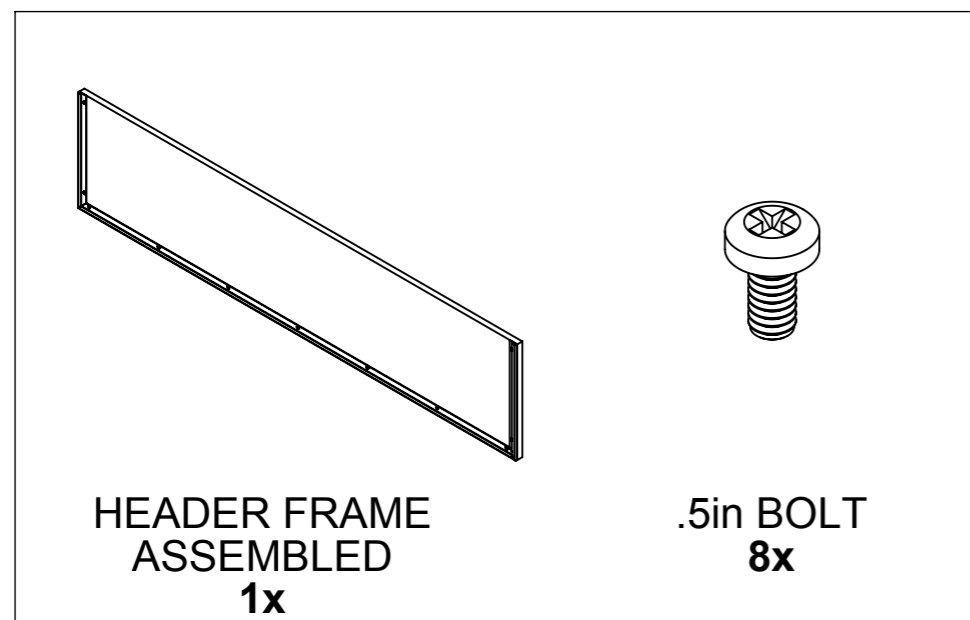

HEADER FRAME  
ASSEMBLED  
1x

.5in BOLT  
8x

REAR VIEW

# Step 6

**Note:**  
Using the Bottom Pivot removed from Step 1 and the new Top Pivot bracket, assemble them to the left side of the display as shown. Remove the wood screw on the leg and re-use the screw to attach the bottom pivot.

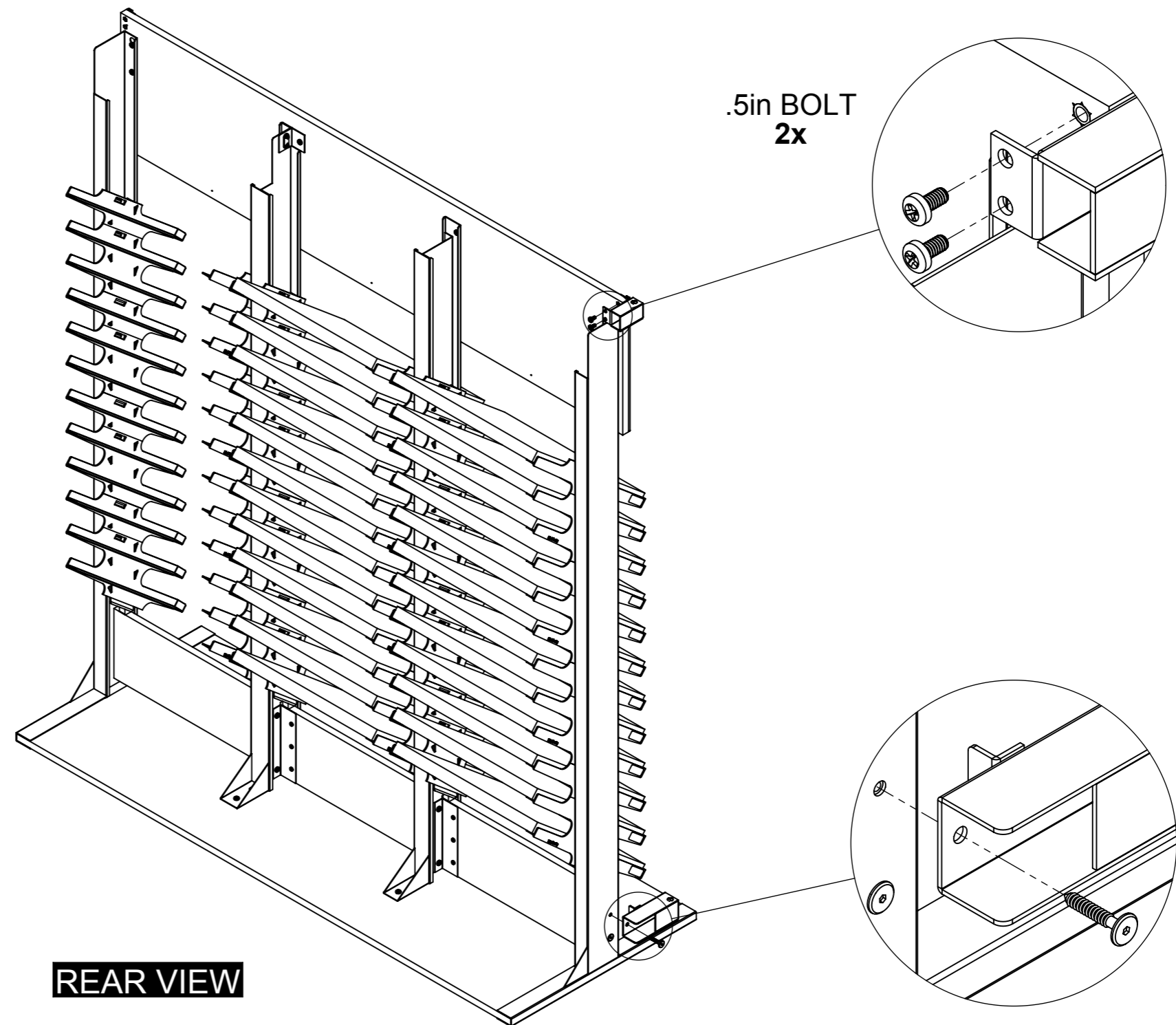
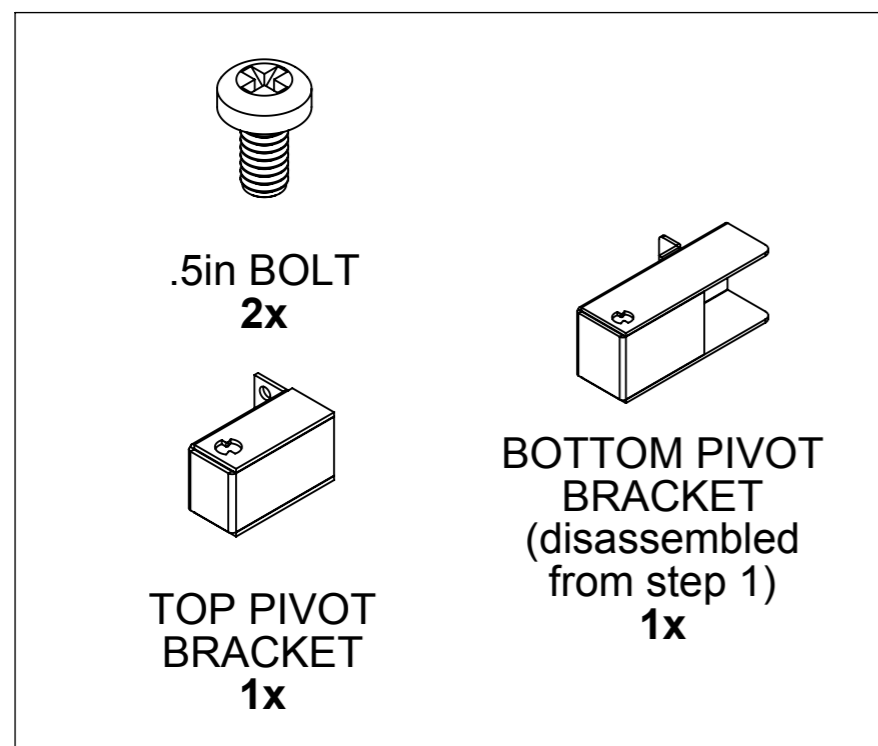

# Step 7

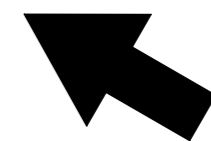
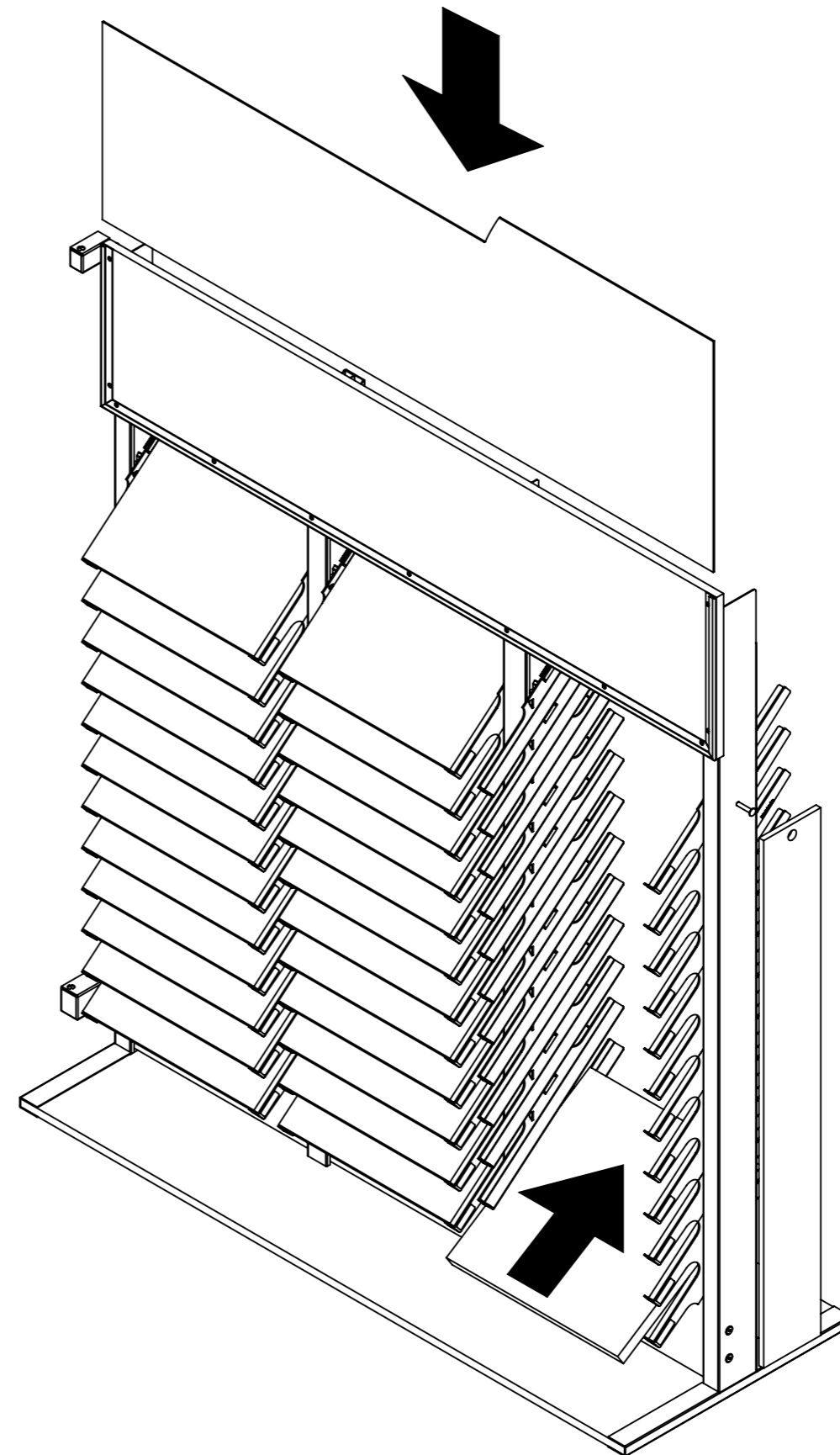
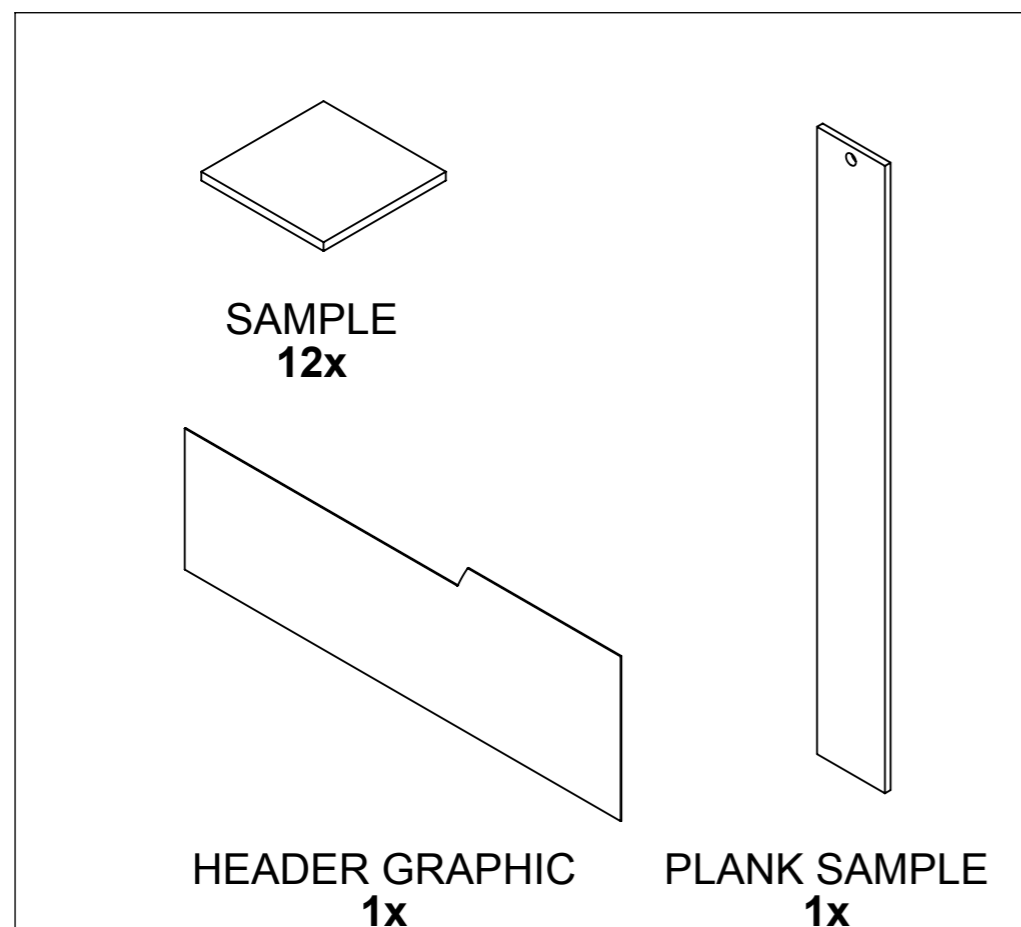

**Note:**  
Install the samples  
according to the  
plan-o-gram that is  
supplied with the  
samples.

# Step 8

**NOTE:**  
Assemble the swinging  
graphic assembled from step 1

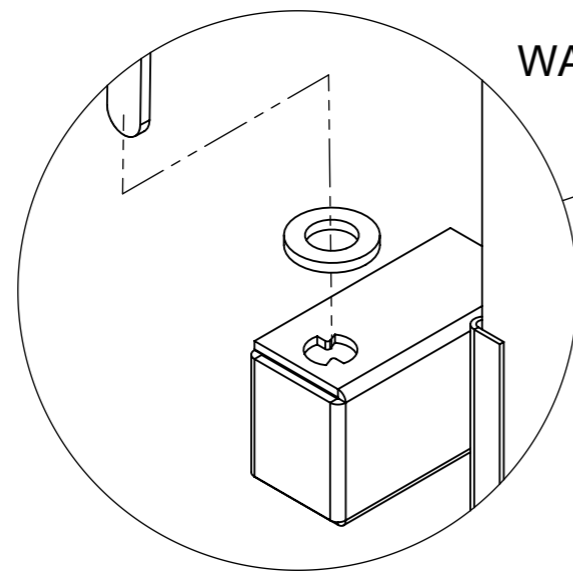

WASHER  
2x

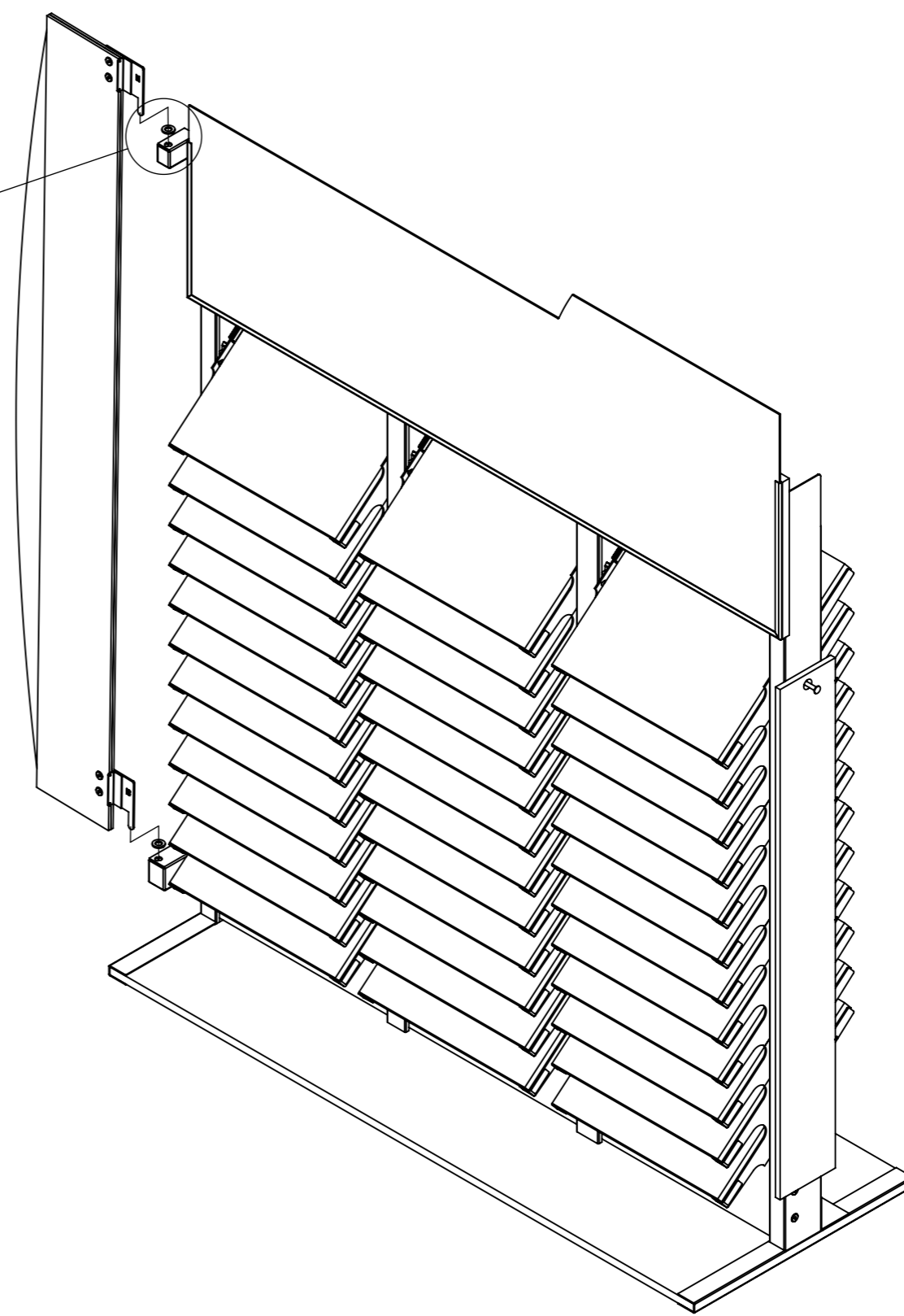
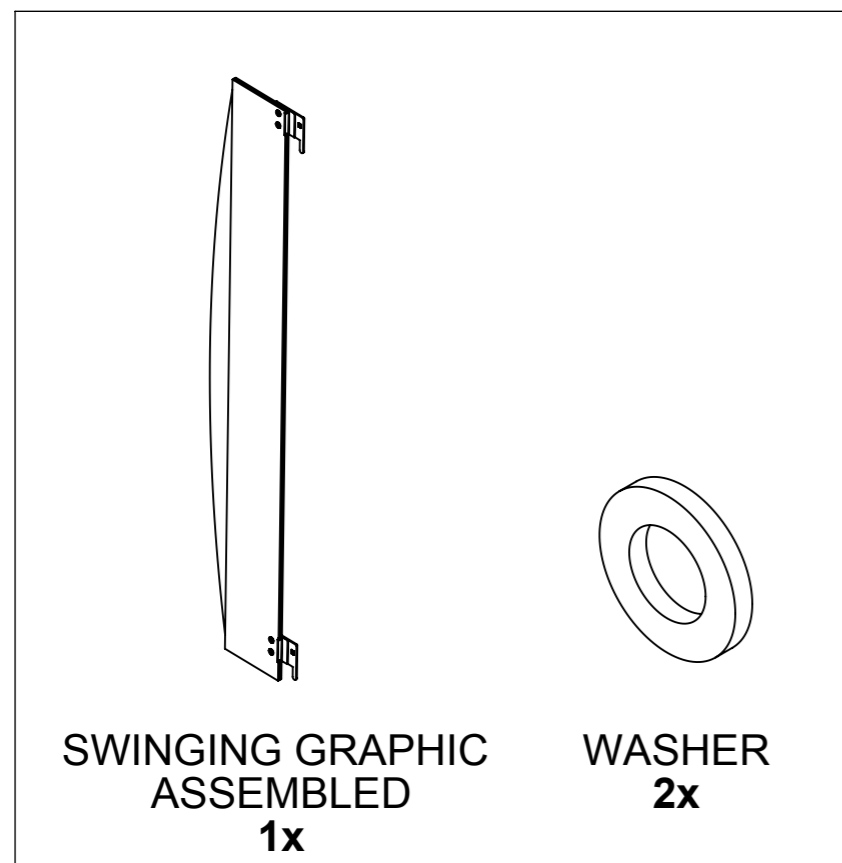

---

**CONGRATULATIONS YOUR INSTALLATION IS COMPLETE**

**NEVER MOVE LOADED DISPLAY**

**MAKE SURE ALL FASTENERS ARE TIGHTENED**