

Mannington Apex

3 Tier Display

ASSEMBLY INSTRUCTIONS

MRACH 2019

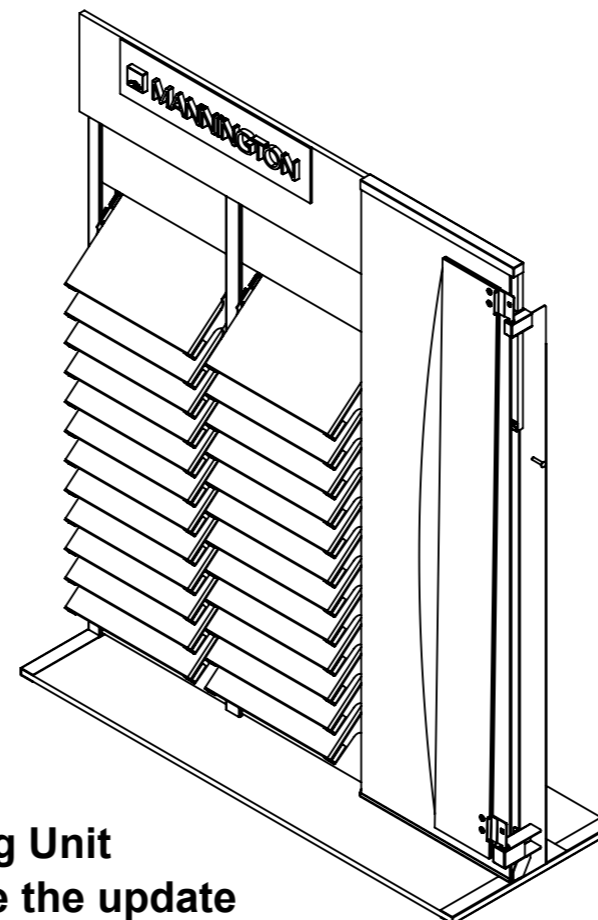

Exiting Unit
Before the update

CARTON CONTENTS

Mannington - 2019 Apex Update - Job 61701 Parts List
March,2019

<u>Order Code</u>	<u>Material</u>	<u>Description (cartons in BOLD)</u>	<u>Carton Qty</u>	<u>Part Qty</u>
800905 801686 n/a	422603 422613 n/a	Apex 2019 Header Frame Header Frame Assembled Instruction Sheet	1	1 1
800906 801687 801688	422606 422614 422615	Apex 2019 Top Pivot Bracket Top Pivot Bracket (new) Hardware Bag	1	1 1
800909 n/a	422612 n/a	Apex 2019 Header Update graphic Header update graphic 2019	1	1
900395 803170	348609 313425	Adura Max Rails (4 sets) AMV Triple Rail Set (L+R) black	1	4

RECOMMENDED TOOLS

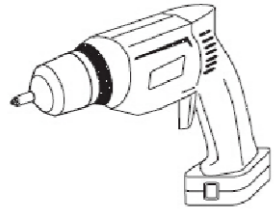

CORDLESS
POWER DRILL



PHILLIPS HEAD
SCREWDRIVER

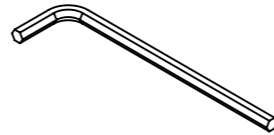

4mm HEX KEY

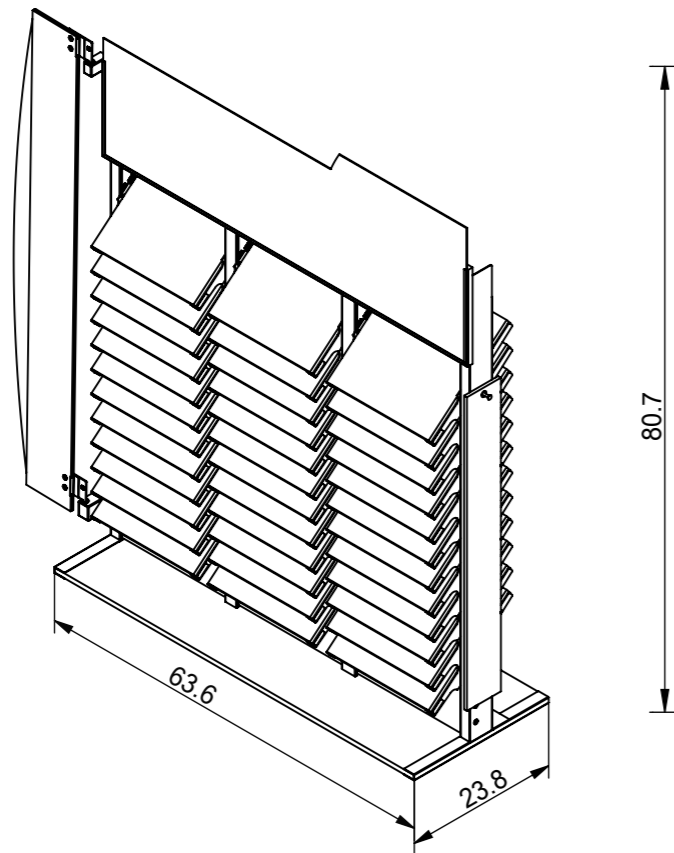

Be sure to provide a minimum of 63.6" to install this display.
Display Foot Print: 63.6" x 23.8" x 80.7"



**HAND TIGHTEN ALL FASTENERS
DURING ASSEMBLY.**

**WHEN ASSEMBLY IS COMPLETED
USE APPROPRIATE TOOLS TO SECURE
ALL FASTENERS PERMANENTLY.**

SAFETY GUIDELINES

**Failure to follow the assembly instructions
could result in damage or injury.**

**Install in a level and stable location. If not on a
level surface please level before installation.**

**Assemble display in the area it will occupy.
Never attempt to move display after loading.**

**When using any power tools, always use
eye protection.**



**Do not work on this display with product in it.
Unload display before relocating unit.
Failure to do this may result in damage or injury.**



**For proper installation and safety follow all steps
in sequential order.**

Two people required to set up this display.



For customer assistance: POPServices@artguildinc.com
or call 877.233.7962 and ask for Mannington representative.

PARTS

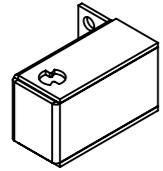

TOP PIVOT
BRACKET
1x

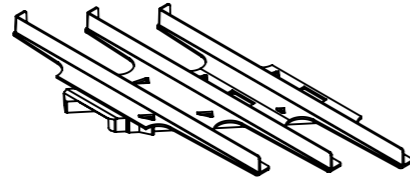

LEFT RAIL
4x

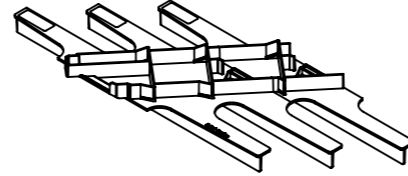

RIGHT RAIL
4x

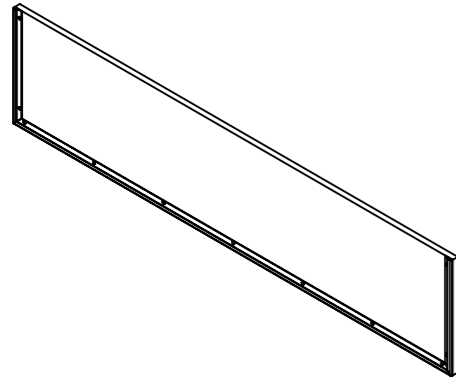

HEADER FRAME
ASSEMBLED
1x

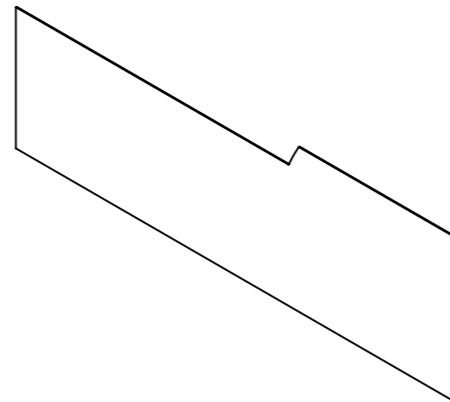

HEADER GRAPHIC
1x

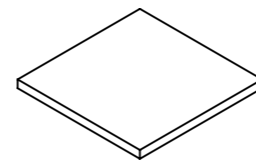

SAMPLE
12x

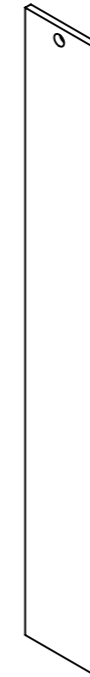

PLANK SAMPLE
1x



For customer assistance: POPServices@artguildinc.com
or call 877.233.7962 and ask for Mannington representative.

HARDWARE

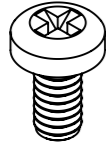

.5in BOLT
10x

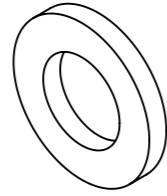

WASHER
2x

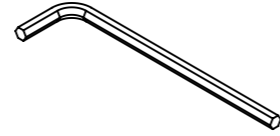

4mm HEX KEY
1x



For customer assistance: POPServices@artguildinc.com
or call **877.233.7962** and ask for Mannington representative.

Step 1

A

NOTE:
Remove the swinging graphic
(keeping hardware to use on the other
side).

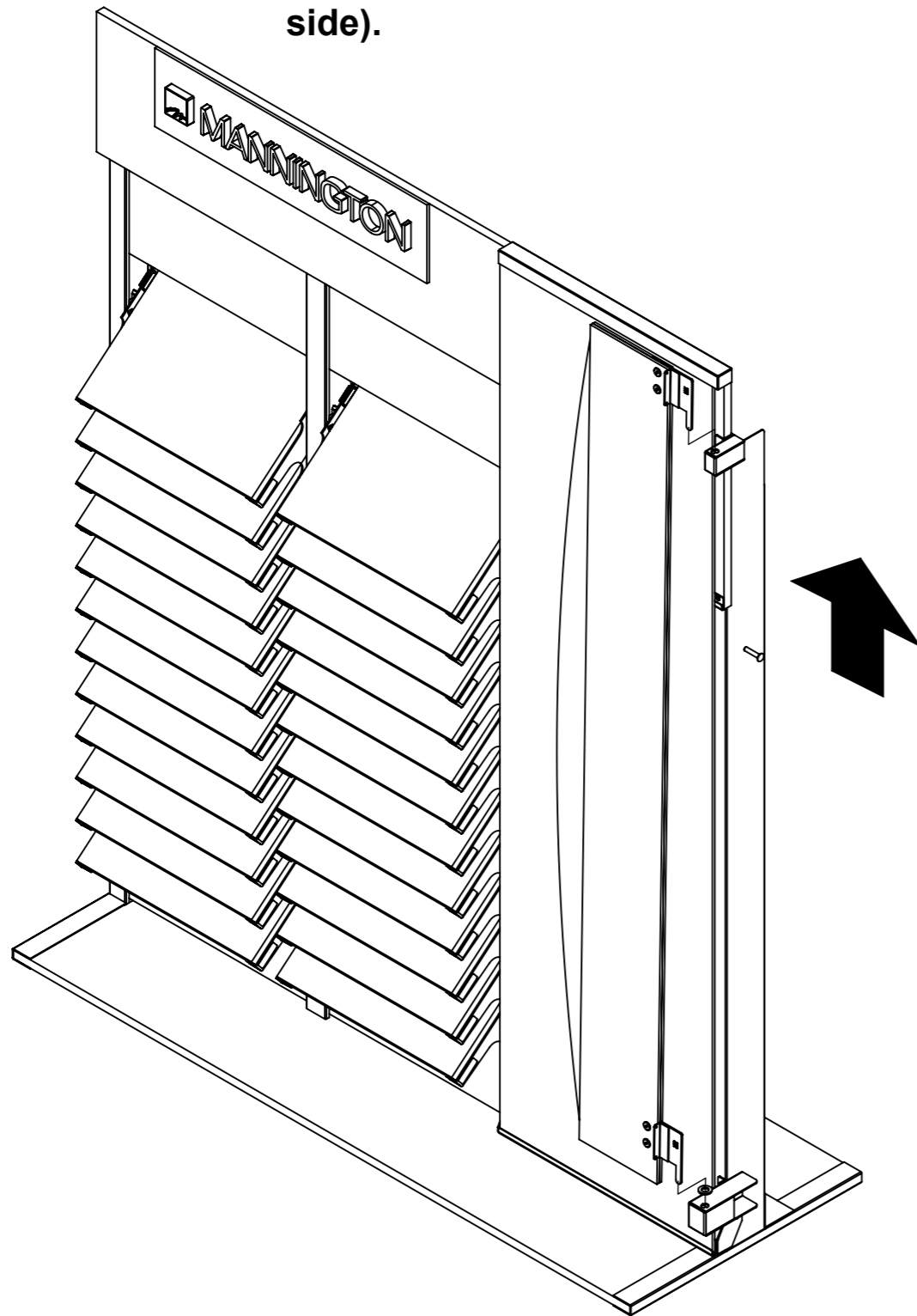

B

NOTE:
Remove the top and bottom pivot.
Keep the bottom pivot and screws
for re-assembly in Step 6. When
the bottom pivot is removed,
re-install the wood screw into the
display.

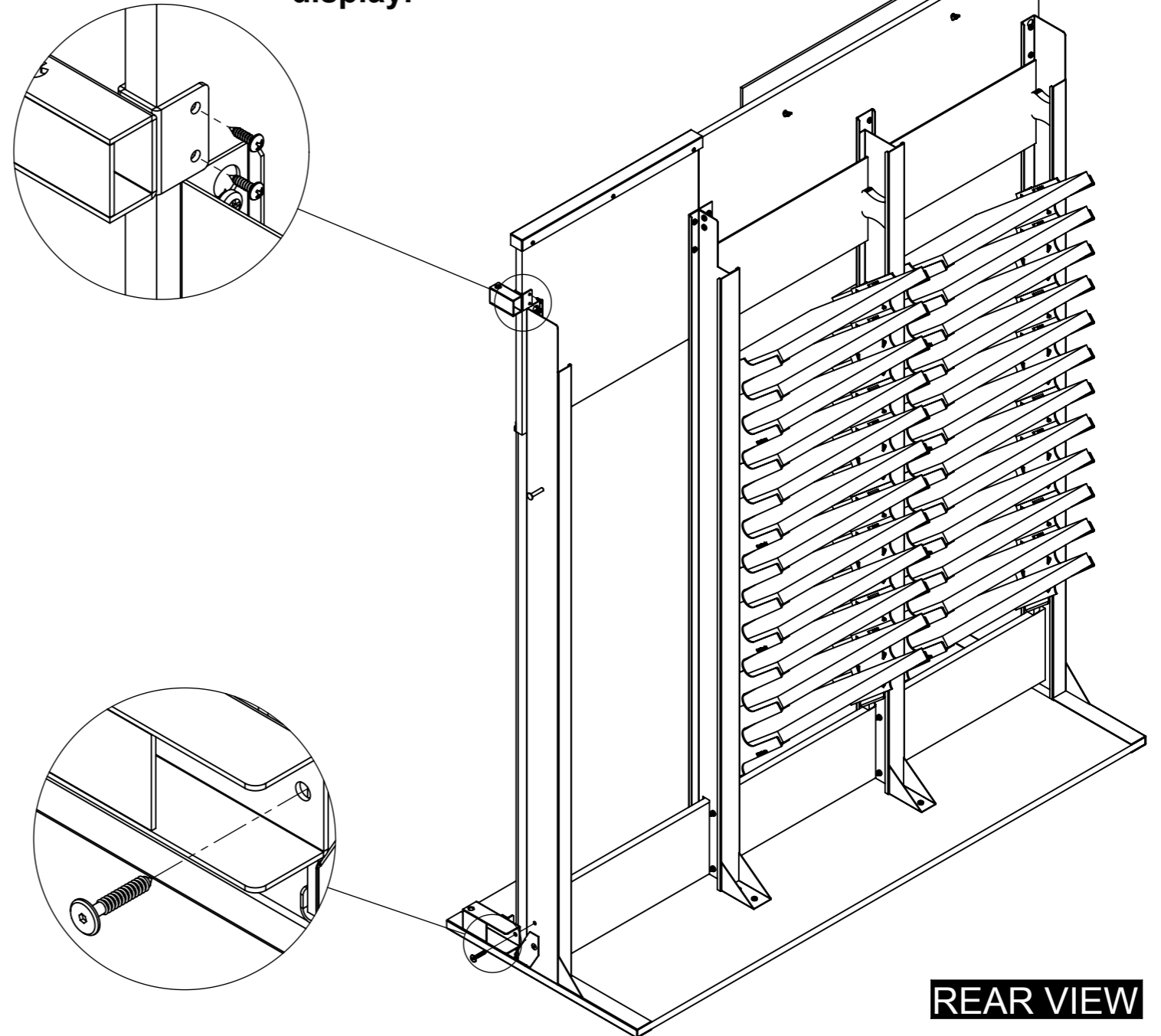

Step 2

A NOTE:
Remove the full sized graphic.

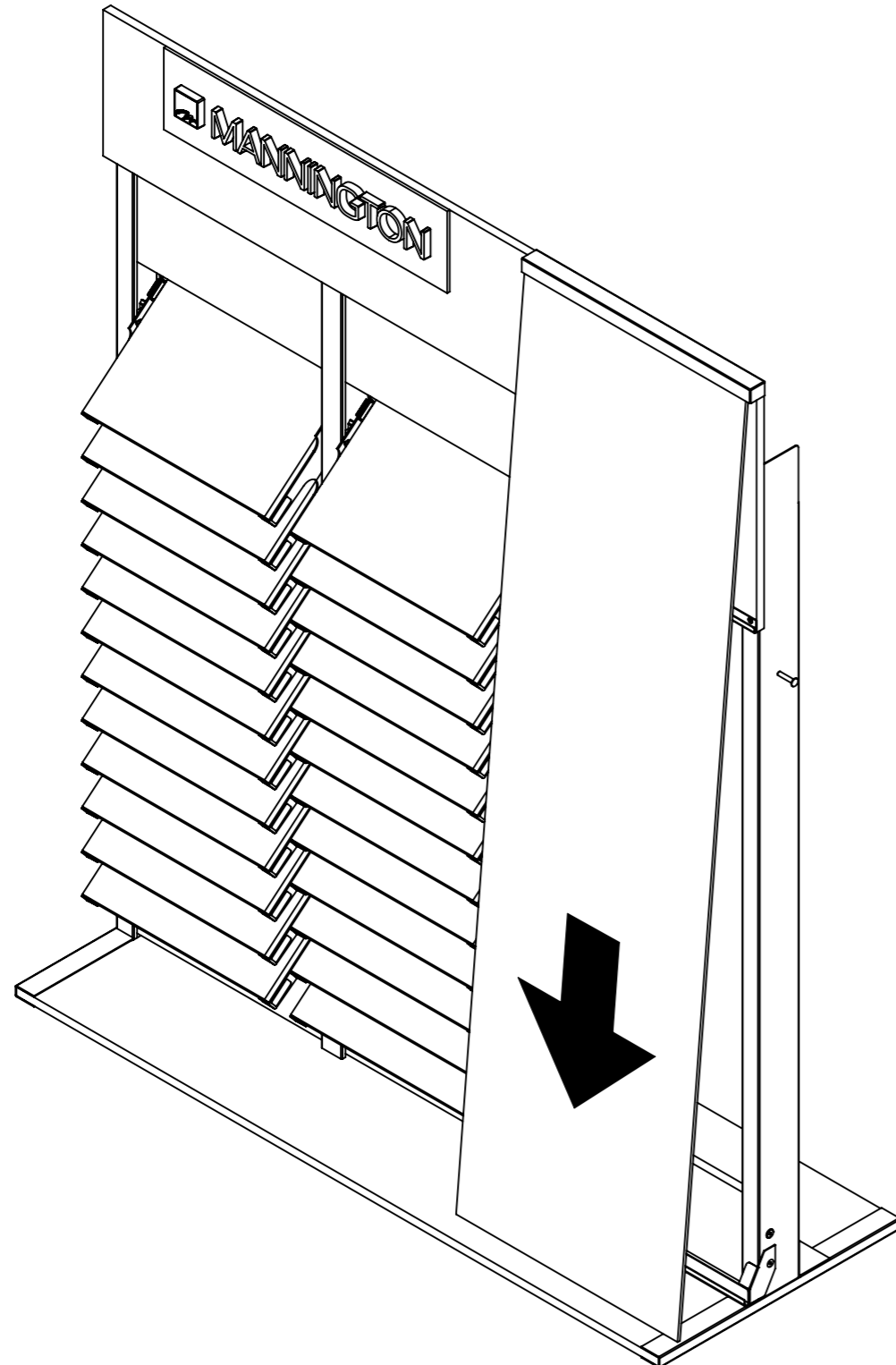

B NOTE:
Remove the Right Header panel.

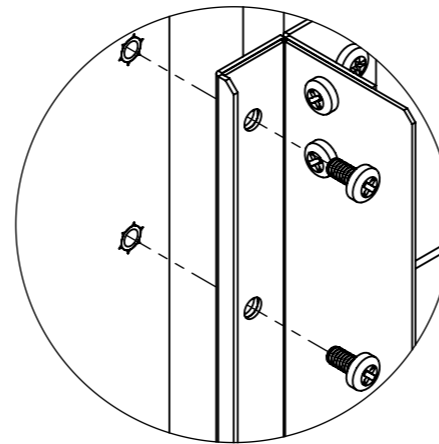

NOTE:
Remove the screw to
remove the component,
then replace the screw.

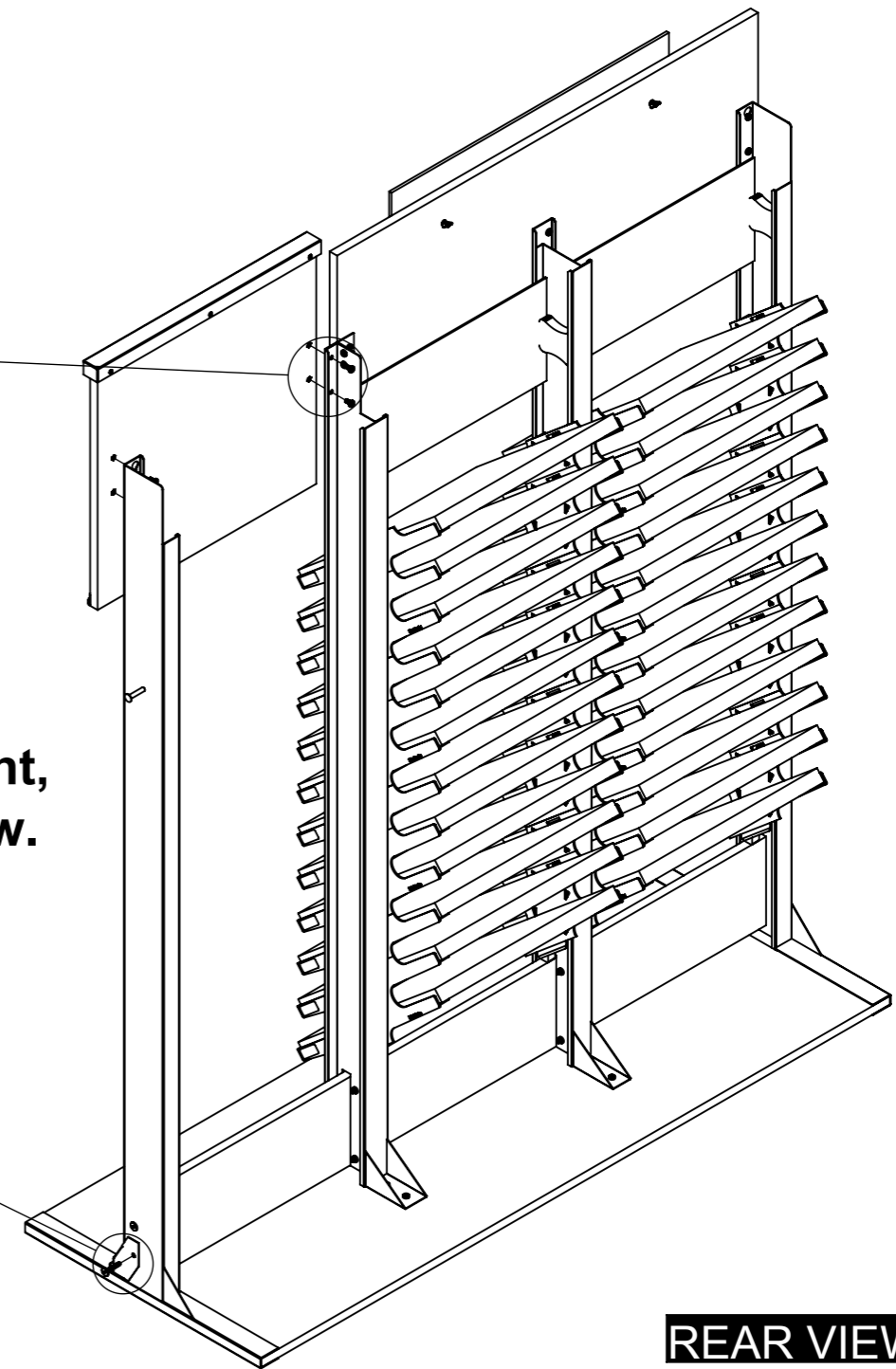
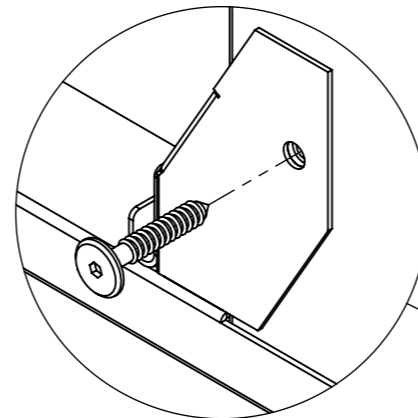

REAR VIEW

Step 3

A

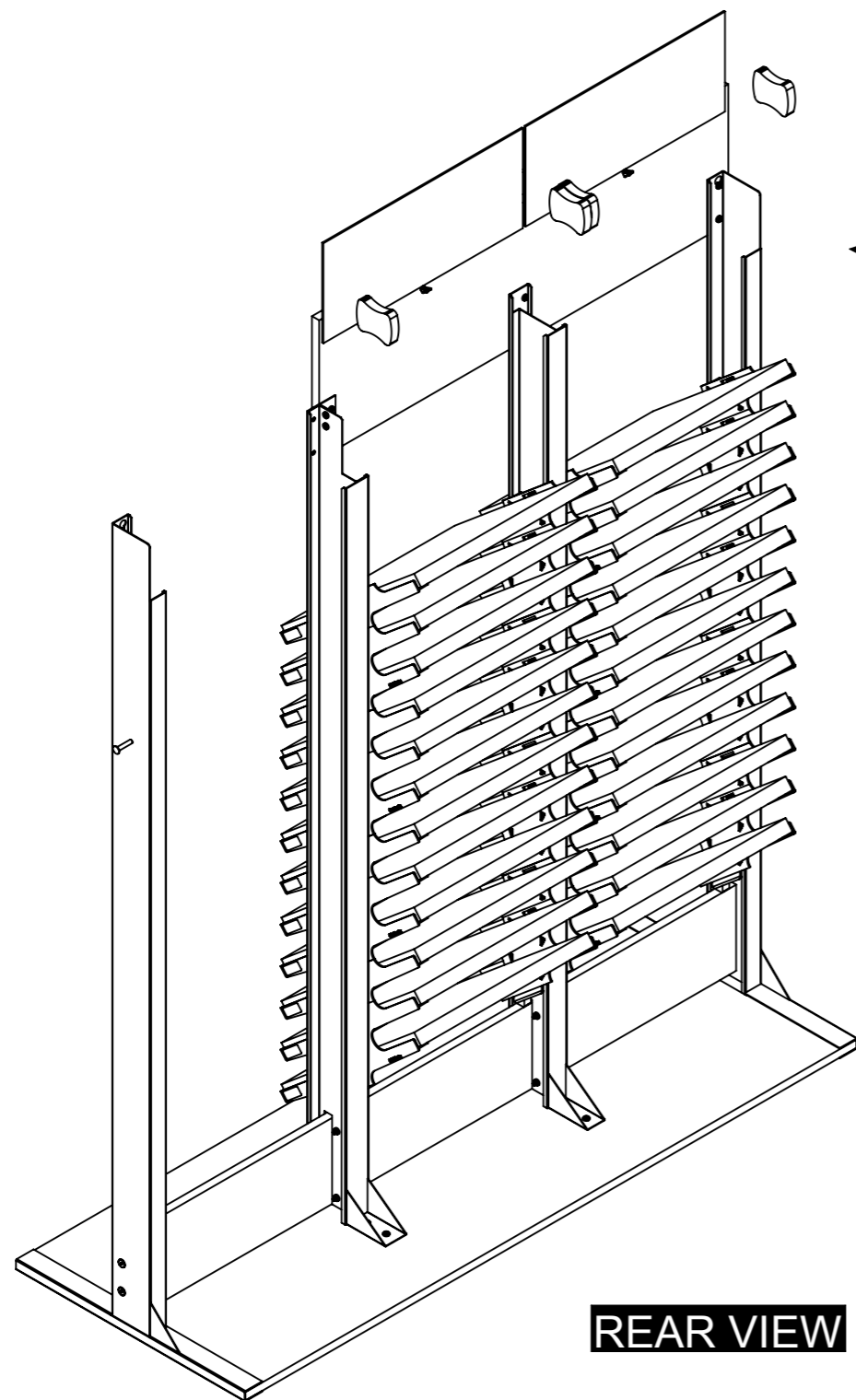

REAR VIEW

B

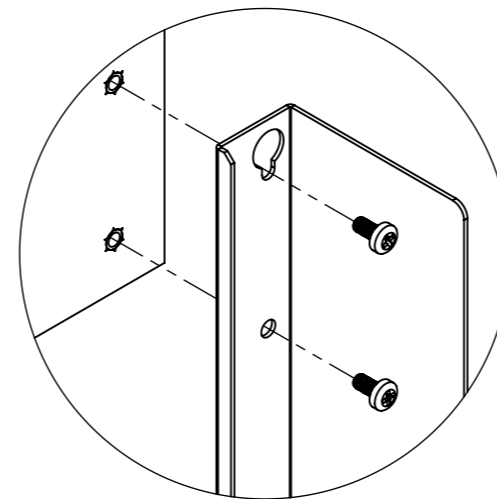

NOTE:
Disassemble the graphic
and header from the old
display for next step.

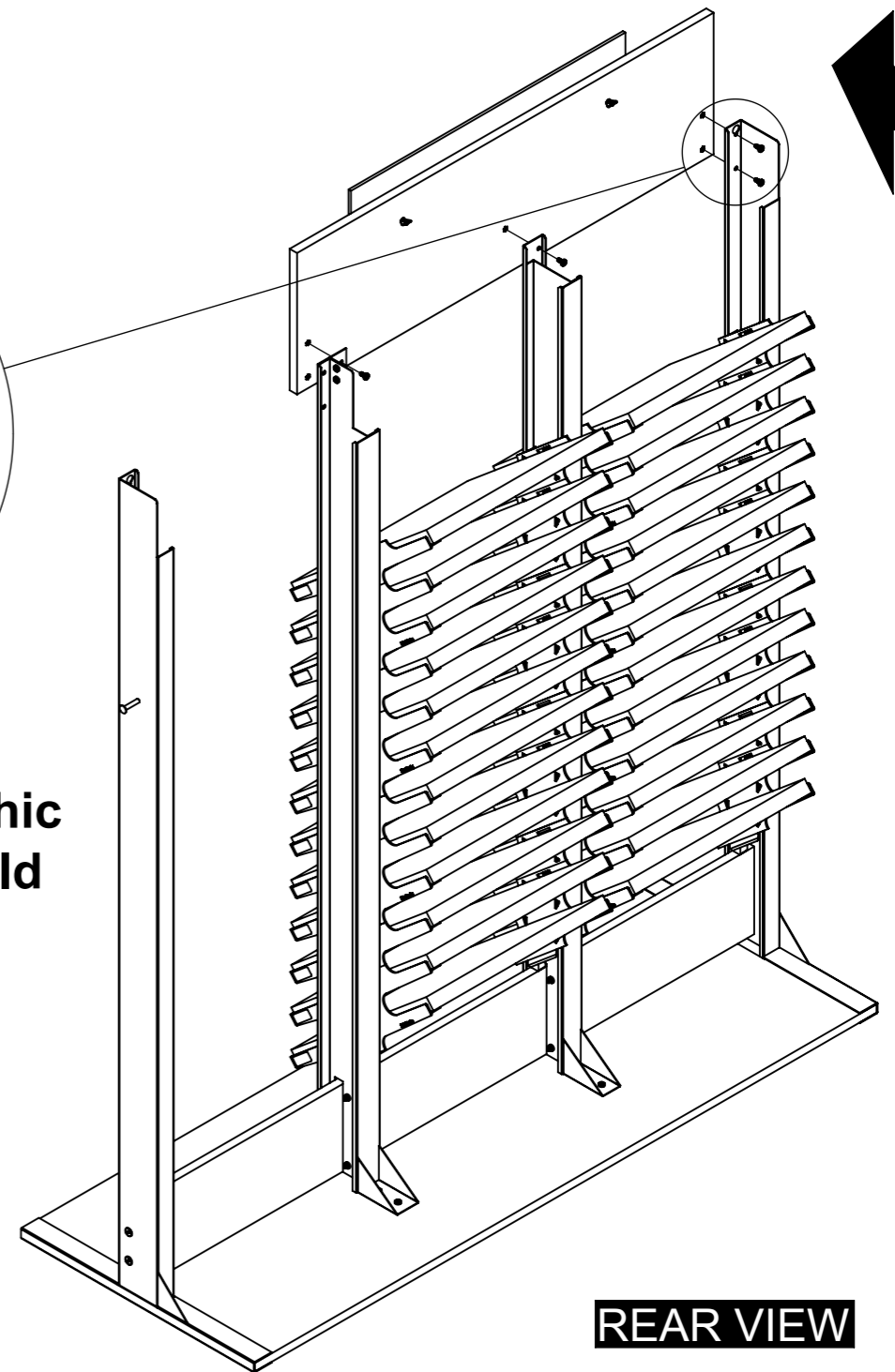

REAR VIEW

Step 4

Note:

Add the 4 left rails and the 4 right rails into the right side of the display.

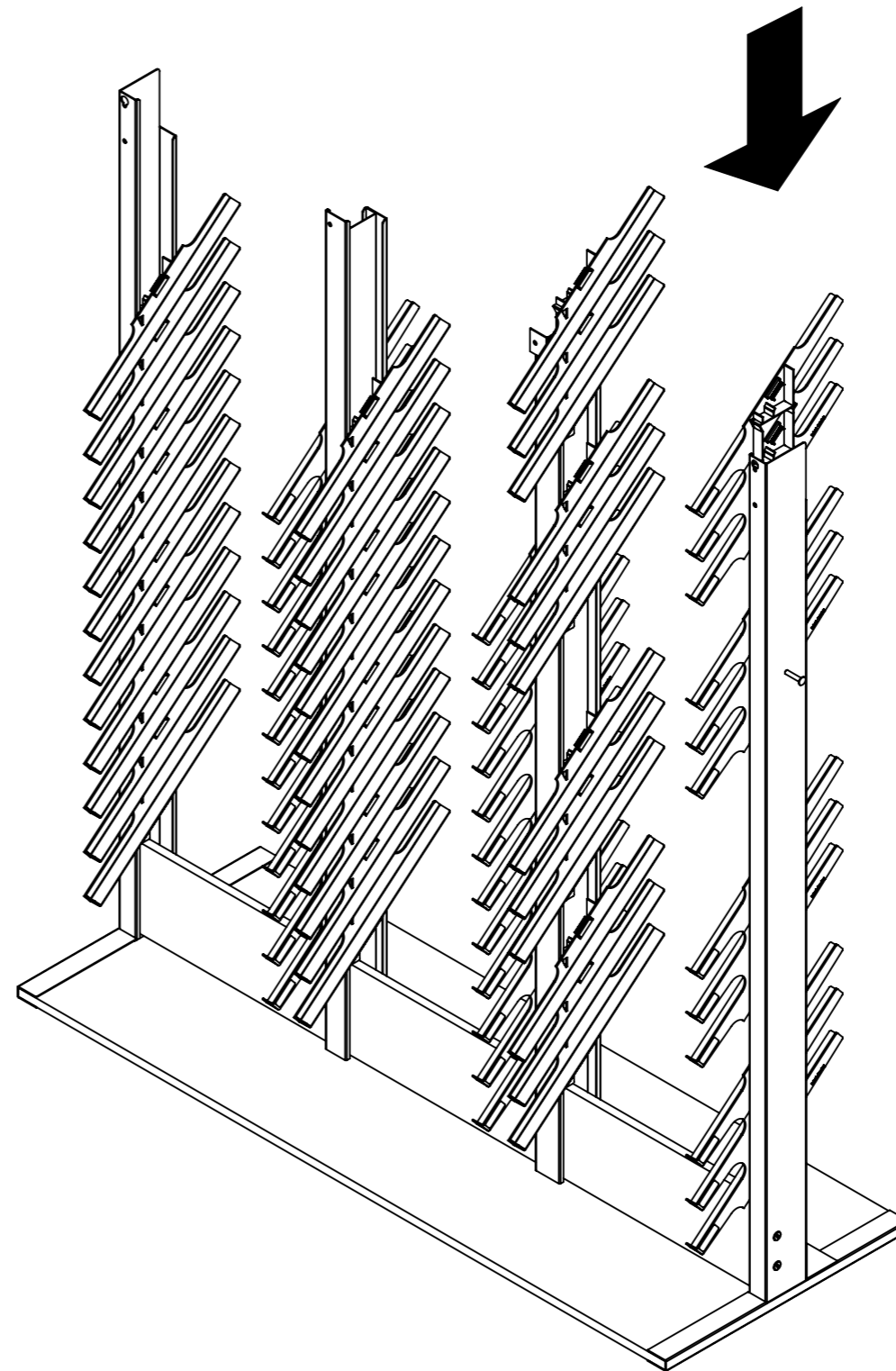
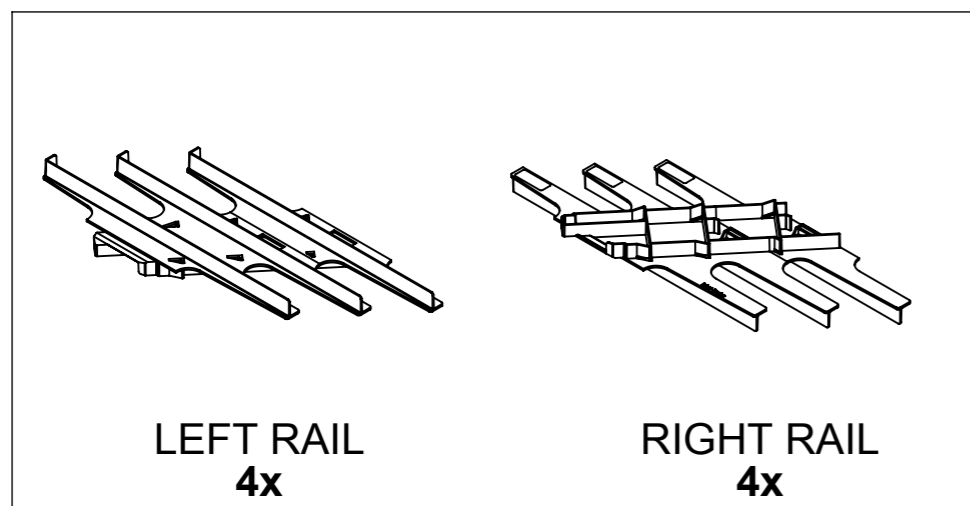

Step 5

Note:

To make installation of the Header Frame easier.

Attach the left and right top screw with about 1/8" exposed. You can hang the header frame onto the display using the key hole slot in the legs.

Then attach the hardware from the back.

Tighten all screws.

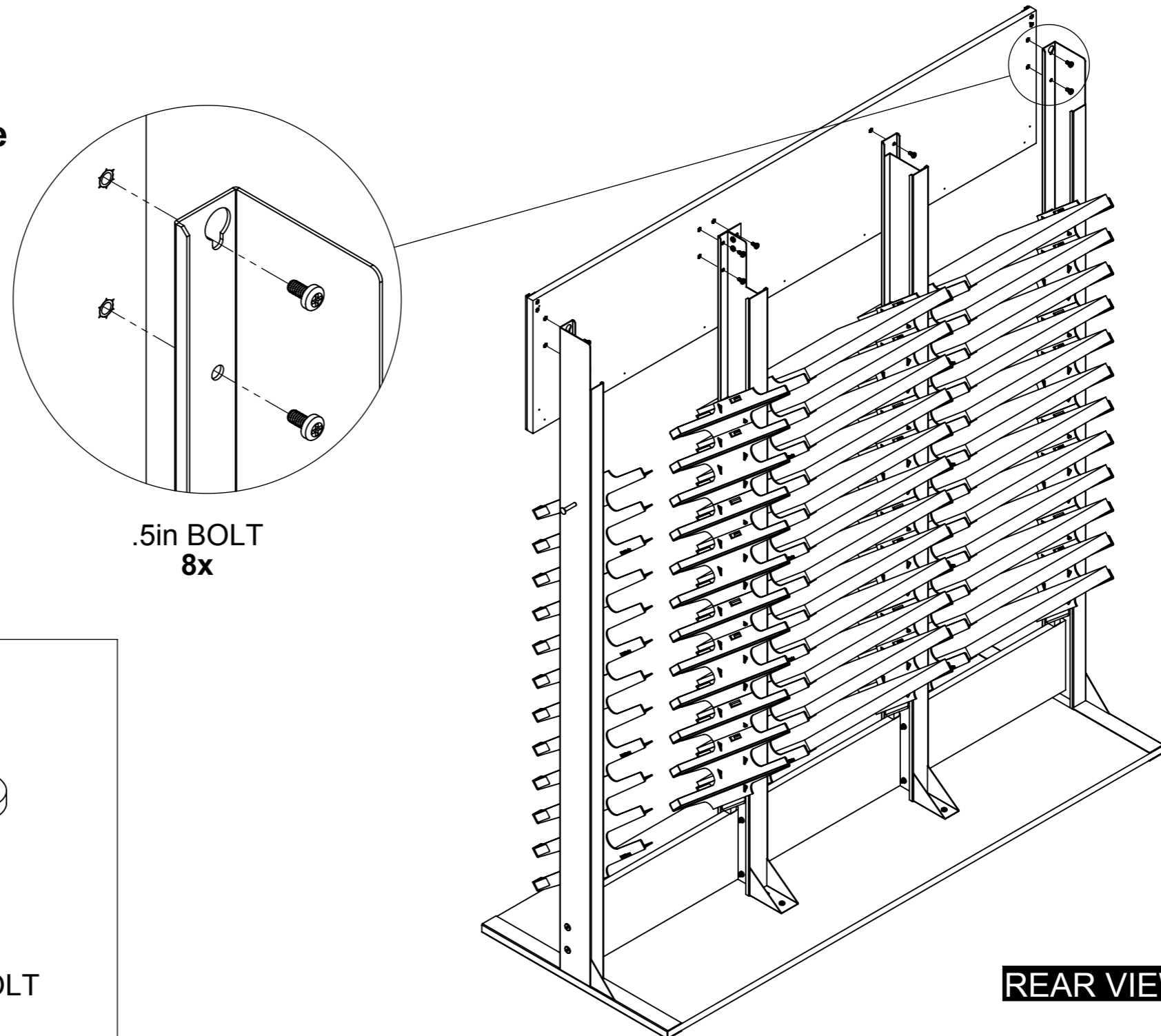

.5in BOLT
8x

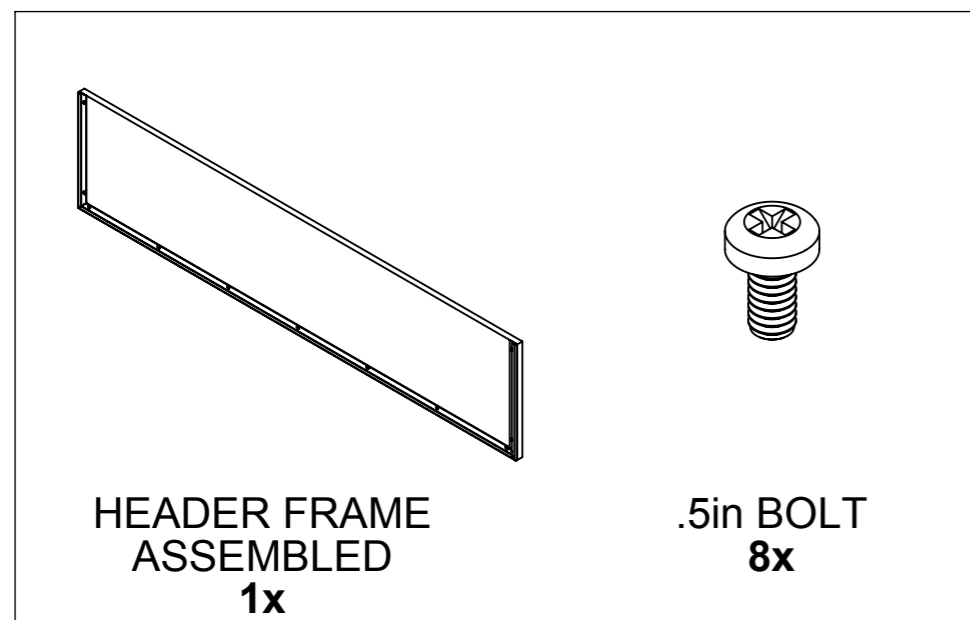

HEADER FRAME
ASSEMBLED
1x

.5in BOLT
8x

REAR VIEW

Step 6

Note:
Using the Bottom Pivot removed from Step 1 and the new Top Pivot bracket, assemble them to the left side of the display as shown. Remove the wood screw on the leg and re-use the screw to attach the bottom pivot.

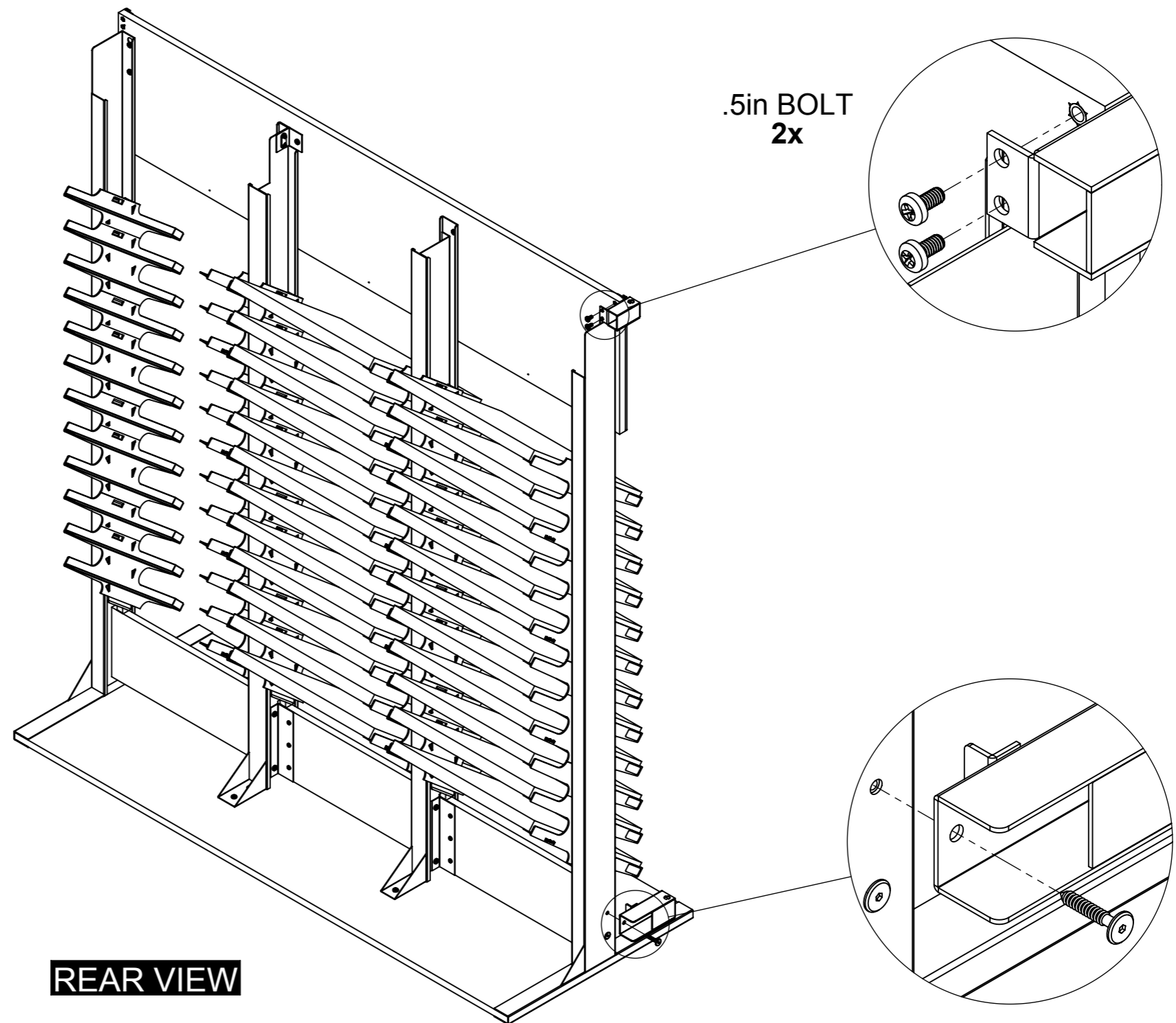
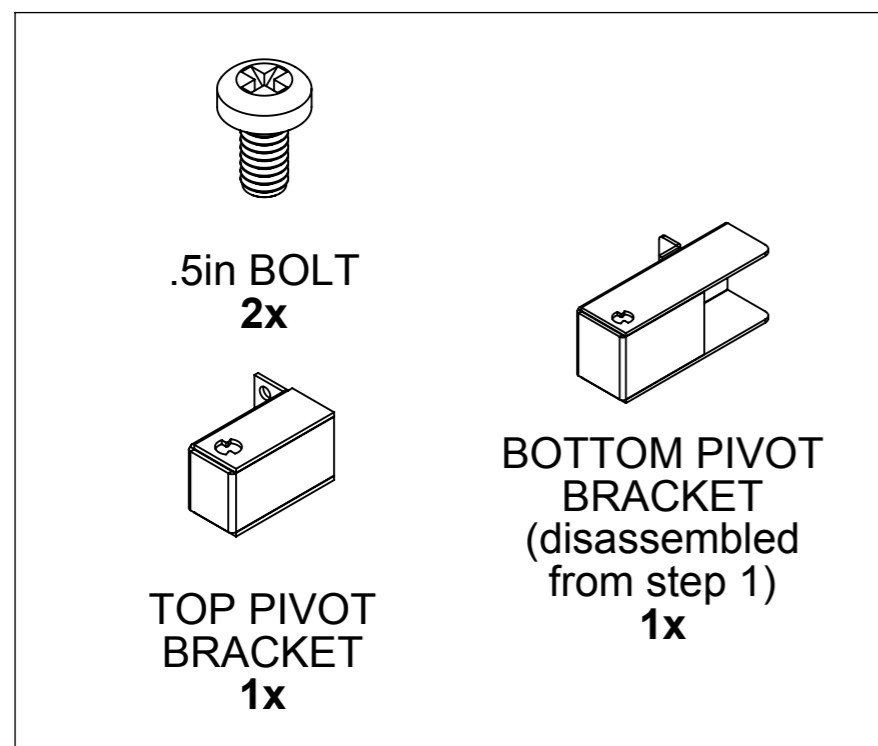

Step 7

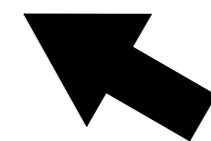
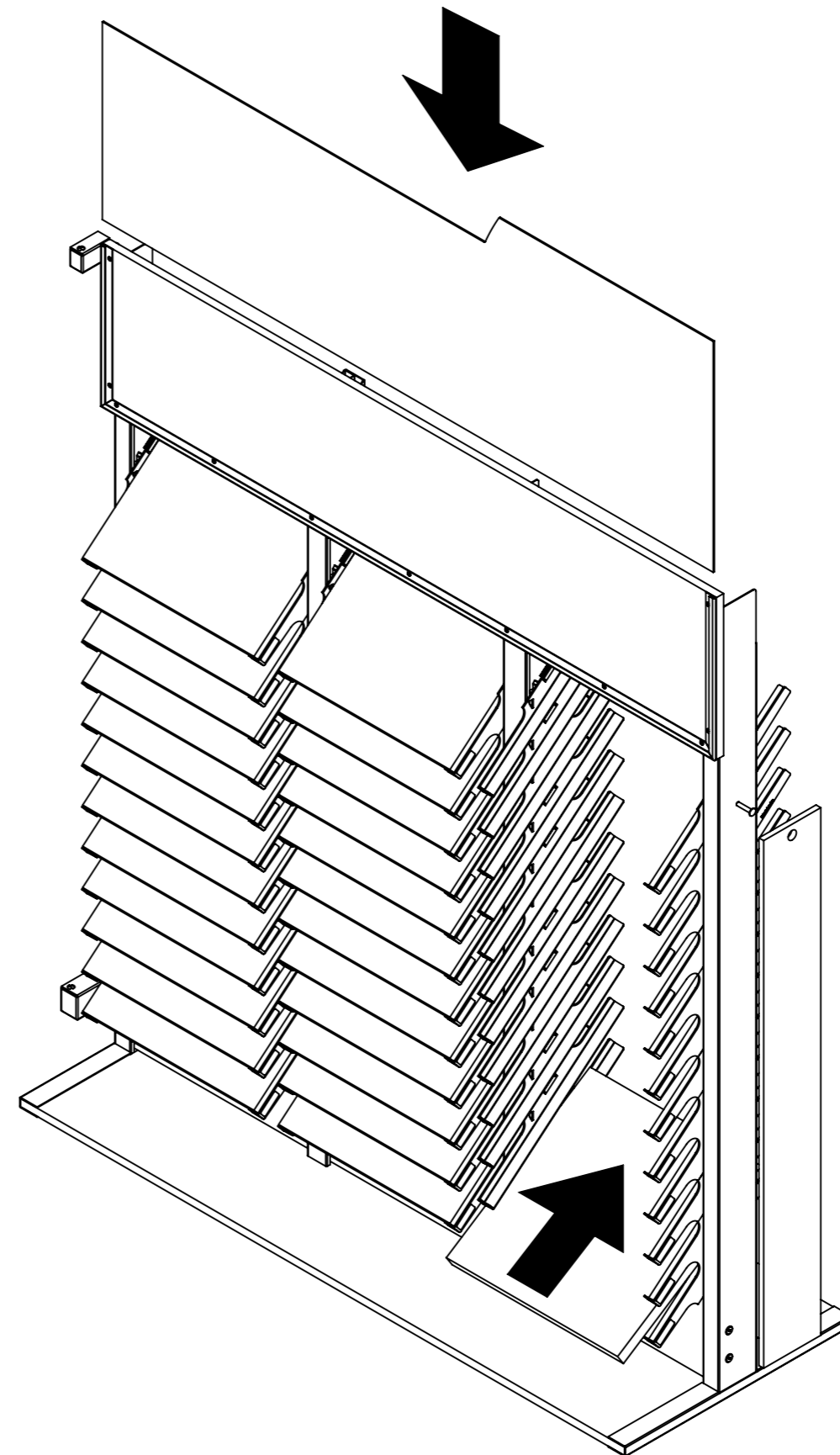
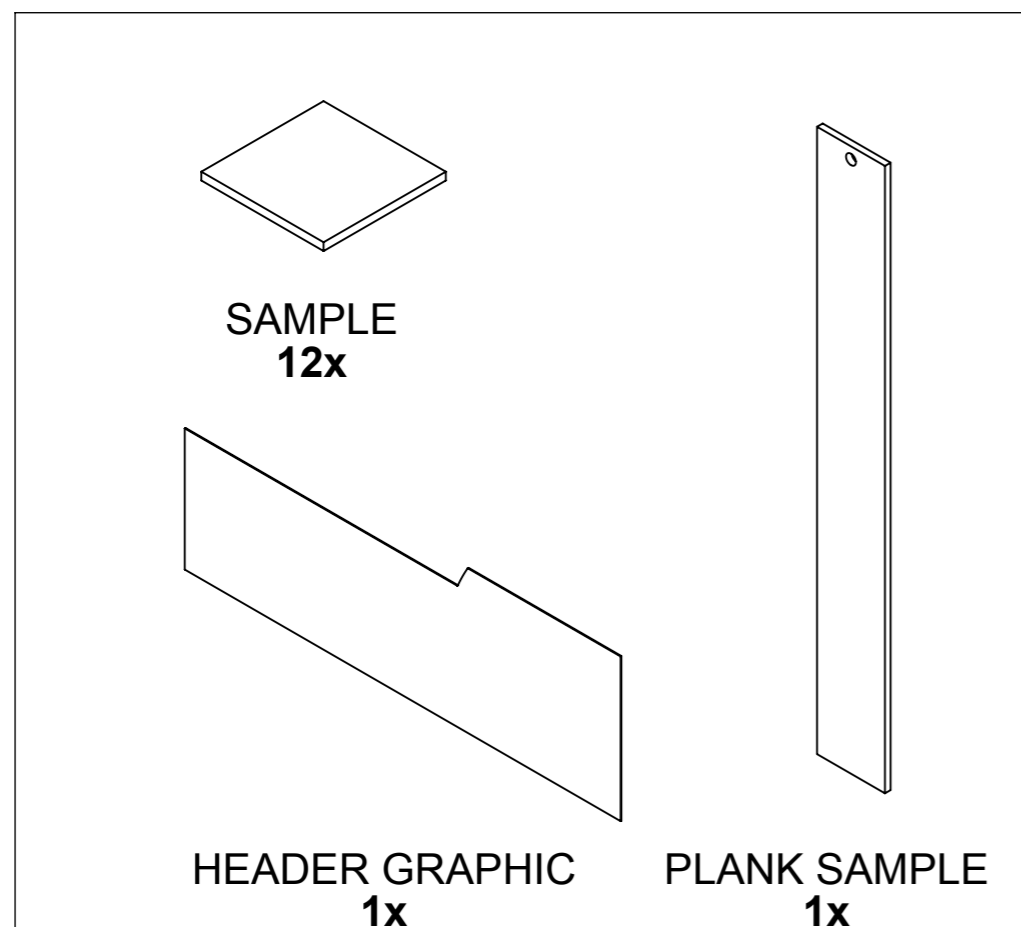

Note:
Install the samples
according to the
plan-o-gram that is
supplied with the
samples.

Step 8

NOTE:
Assemble the swinging
graphic assembled from step 1

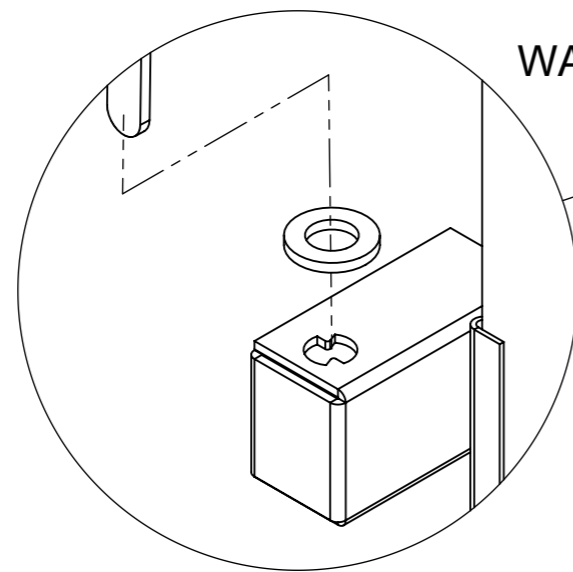

WASHER
2x

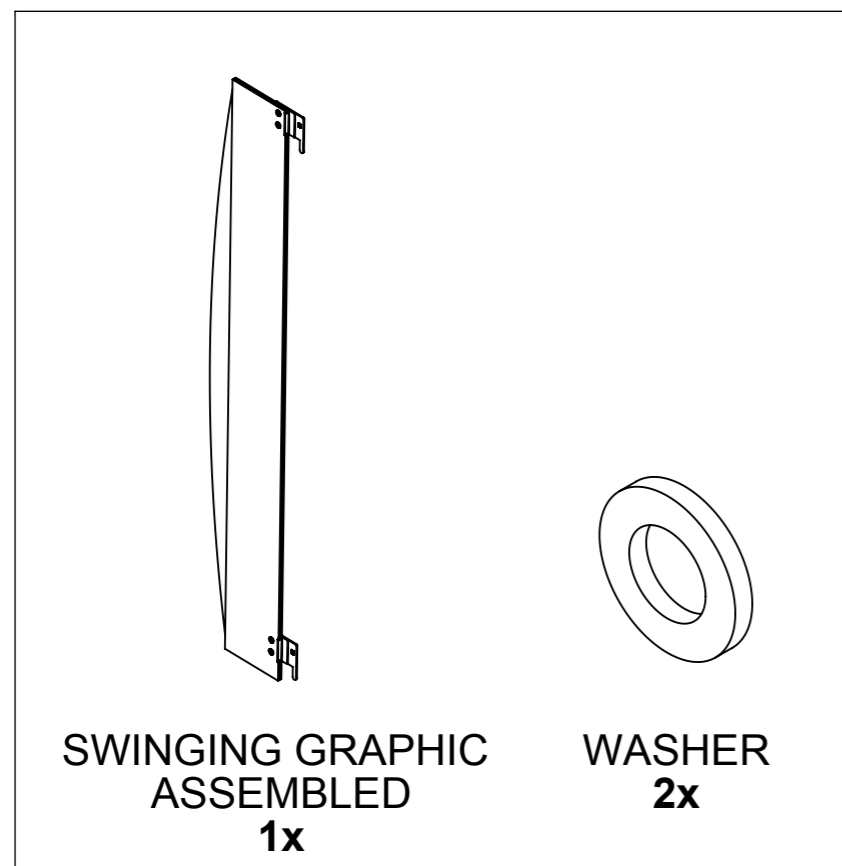

SWINGING GRAPHIC
ASSEMBLED
1x

WASHER
2x

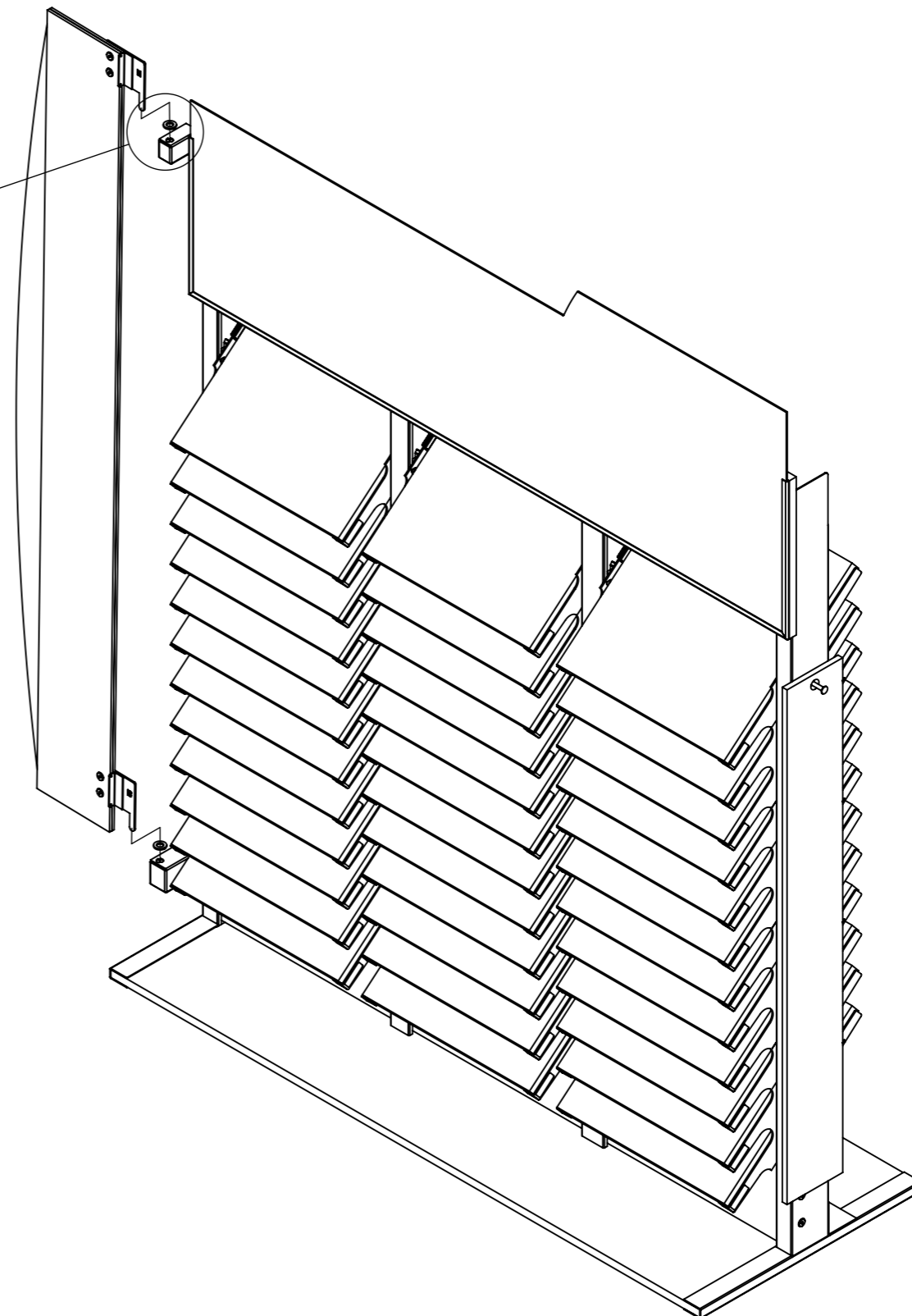

**CONGRATULATIONS YOU HAVE SUCCESSFULLY ASSEMBLED
THE Mannington Apex 3 Tier Display**

NEVER MOVE LOADED DISPLAY

MAKE SURE ALL FASTENERS ARE TIGHTENED