

Posterior Referencing

Persona® The Personalized Knee

Surgical Technique



Table of Contents

- Introduction** 2
 - Instrumentation
 - Magnet Usage
 - Symbols
 - Screw/Pin Information
- Caution** 4
- Size Femur and Establish External Rotation** 5
- Complete Femoral A/P and Chamfer Resections** 8
- Optional Instrument** 9

Introduction

Instrumentation

Successful total knee arthroplasty depends in part on re-establishment of normal lower extremity alignment, proper implant design and orientation, secure implant fixation, and adequate soft tissue balancing and stability. Persona: The Personalized Knee, Posterior Referencing Instruments are designed to help the surgeon accomplish these goals by combining alignment accuracy with a simple, straight-forward technique. The instruments and technique assist the surgeon in restoring the center of the hip, knee, and ankle to lie in a straight line, establishing a neutral mechanical axis. The femoral and tibial components are oriented perpendicular to this axis. Femoral rotation is determined using the posterior condyles, the epicondylar axis, or Whiteside's line as a reference. The instruments facilitate accurate cuts to help ensure robust component fixation. A wide variety of component sizes, shapes, and constraint options allow for more optimized component fit and soft tissue balancing. The femur, tibia, and patella are prepared

independently, and can be cut in any sequence using the principle of measured resection (removing enough bone to allow replacement by the prosthesis). Adjustment cuts may be needed later. The posterior referencing technique uses the posterior condylar axis to set the A/P position of the femoral component. The cut of the anterior aspect of the femur is variable in 2 mm increments offered by the Persona System.













Note: The intent of this surgical technique is to explain the surgical steps for posterior reference based on 4-in-1 cut guide selection, hole preparation for placement of 4-in-1 cut guides, and subsequent femoral resections. For the surgical steps of resecting and finishing the tibia and patella, please refer to Persona Surgical Technique (Lit #97-5026-001-00). Refer to Section 12 of the Persona Surgical Technique (Lit # 97-5026-001-00) for final femoral, tibial, and patellar implantation. All surgical techniques should be referenced at the time of surgery.

Magnet Usage

Warning: Some instruments in the Persona System contain magnets. All Persona Magnetic Instruments should be kept at a safe distance from a patient’s active implantable medical device(s) (i.e. pacemaker). These types of devices may be adversely affected by magnets. Instruments containing magnets should be kept on an appropriate table or stand when not in use at the surgical site.

Symbols

Symbols have been established for the following:

- Left  Left
- Right  Right
- Varus/Valgus  Varus/Valgus
- Medial/Lateral  Medial/Lateral
- Standard  Standard
- Do not implant – Not for implant  Do not implant - Not for implant
- Lock  Lock
- Unlock  Unlock
- Anterior Referencing  Anterior Referencing
- Do not impact  Do not impact
- Cemented  Cemented
- Stemmed  Stemmed
- Inset Only  Inset Only

Screw/Pin Information

The chart below contains relevant information on various 3.2 mm screws/pins that are compatible with the Persona System. If these screws/pins are used during the procedure for instrument fixation, they should be removed prior to closure as they are NOT implantable.

Note: The 2.5 mm female hex screws and 2.5 mm male hex driver should not be used in cortical bone, as this may increase the incidence of stripping of the driver.

Screw/Pin	Screw/Pin Item #	Compatible Driver	Shipped Sterile/ Non-sterile	Quantity per Package	Single use?
	25 mm x 2.5 mm Female Hex Screw 42-5099-025-25*	 2.5 mm Male Hex Driver 42-5099-025-00	Sterile	2	Yes
	75 mm x 3.2 mm Trocar Tipped Drill Pin (2.5 mm hex) 00-5901-020-00	 Pin/Screw Insertor 00-5901-021-00	Sterile	4	Yes
	Hex Headed Screw 33 mm long 00-5901-035-33		Sterile	2	Yes
	MIS Quad-Sparing Total Knee Headed Screw 48 mm long 00-5983-040-48	 Screw Insertor/Extractor 00-5983-049-00	Sterile	1	Yes
	25 mm Shorthead Holding Pin 00-5977-056-03	 Multi Pin Puller 00-5901-022-00	Non-Sterile	1	No

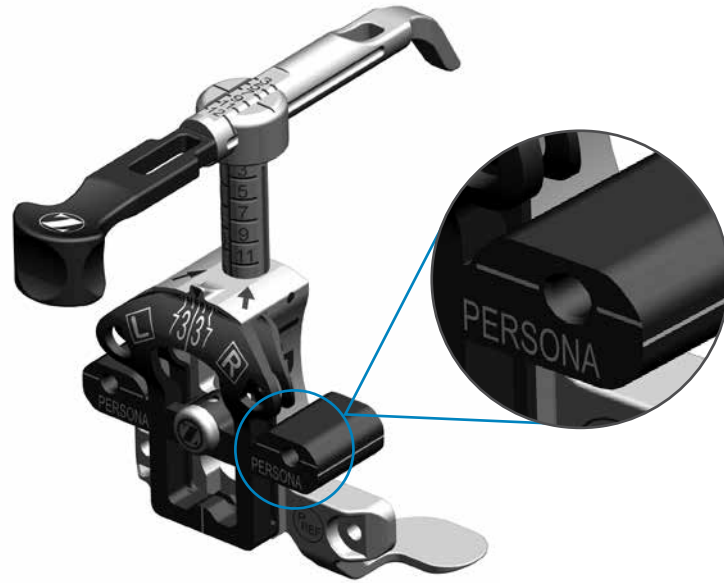

Persona Posterior Referencing Sizer
42-5099-040-00 and 42-5099-040-10

Caution

Only use Persona Posterior Referencing Sizer (42-5099-040-00) and Persona Posterior Referencing Sizer Boom (42-5099-040-10) with Persona Posterior Referencing 4-in-1 Cut Guides sizes 3–12 (42-5099-044-54/74).

Persona Posterior Referencing 4-in-1 Cut Guides are not compatible with legacy instrument systems.

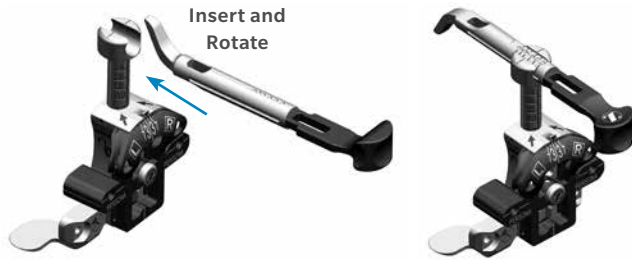

Figure 1

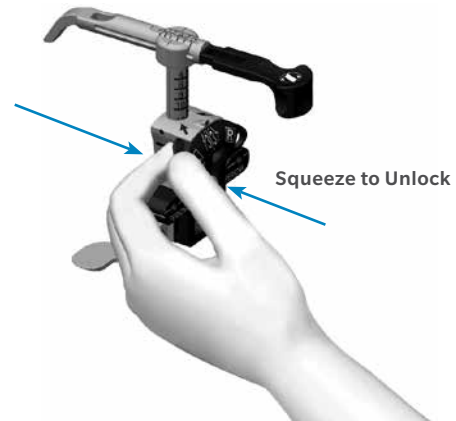

Figure 2

Size Femur and Establish External Rotation

Assemble the posterior referencing sizer boom with the posterior referencing sizer (Figure 1).

Establish the initial external rotation setting by holding the body (silver portion) of the sizer in one hand, positioning the opposite index finger behind the “L” or “R” with the thumb over the “L” or “R”, squeeze, adjust to desired setting and release (Figure 2). External rotation can be set at 0, 3, 5, 7, or 9 degrees left or right.

ⓘ Technique Tip: Remove any osteophytes that interfere with instrument positioning.

Apply the sizer so that the flat surface of the sizer is flush against the resected surface of the distal femur and the feet of the sizer are flush against the posterior condyles. Center the sizer mediolaterally. After positioning the sizer, the external rotational setting can be verified or adjusted. Both the vertical and horizontal portions of the sizer provide visual cues relative to the A/P and epicondylar axes of the femur to help ensure that desired rotational adjustment is attained.

Persona Posterior
Referencing Sizer
42-5099-040-00



Persona Posterior
Referencing Sizer Boom
42-5099-040-00





Figure 3



Figure 4

Size Femur and Establish External Rotation (cont.)

While holding the guide in place and if necessary, secure the sizer to the femur using 25 mm x 2.5 mm screws (Figure 3) in one or both of the holes on the lower portion of the guide to help draw the sizer adjacent to the distal femur, particularly in MIS situations. Use of 48 mm screws in the region is not recommended due to potential perforation through the posterior femoral condyles.

ⓘ Technique Tip: Do not impact the sizer onto the femur.

Slightly extend the knee and retract soft tissues to expose the anterior femoral cortex. Clear any soft tissue from the anterior cortex. Ensure that the leg is in less than 90 degrees of flexion (70-80 degrees). This will decrease the tension of the patellar tendon to facilitate placement of the sizing boom. The position of the boom tip approximates the proximal position of the anterior

flange of the femoral component. The sizing boom can be rotated to facilitate insertion under the soft tissue envelope. A palpable indication, as well as size markings on the top portion of the sizing boom, ensures that the sizing boom is rotated to the correct position.

ⓘ Technique Tip: Positioning the sizing boom tip on the “high” part of the femur by lateralizing the location of the sizing boom tip can often lessen the likelihood of notching the femur.

After the sizing boom is appropriately positioned, read the femoral size directly from the sizer, between the arrowed engraved lines on the sizer tower (Figure 4). There are 10 sizes labeled 3 through 12.

ⓘ Technique Tip: For patients with femoral sizes smaller than size 3, use Persona Anterior Referencing Surgical Technique.

Persona Posterior Referencing Sizer
42-5099-040-00



Persona Posterior Referencing Sizer Boom
42-5099-040-10



25 mm x 2.5 mm Female Hex Screw
42-5099-025-25



2.5 mm Male Hex Driver
42-5099-025-00



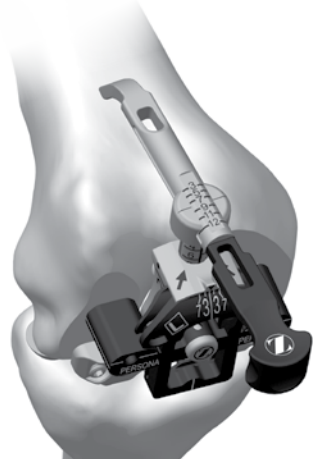

Figure 5



Figure 6

Size Femur and Establish External Rotation (cont.)

The same size markings are present on the anterior surface of the sizing boom and approximate the proximal position of the anterior flange of the femoral component when telescoped to the same size that has been determined by the vertical A/P sizing tower (Figure 5).

The holes in the midline of the A/P portion of the sizer are used to drill 3.2 mm holes for pegs on the posterior referencing 4-in-1 femoral cut guides. Drill through the Persona Posterior Referencing Sizer's holes while being careful not to disturb the position of the sizer during drilling (Figure 6).

3.2 mm Drill
00-5120-085-00



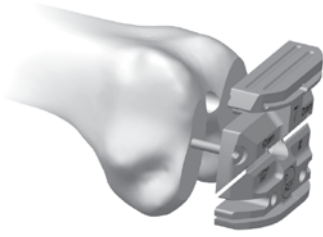

Figure 7



Figure 8

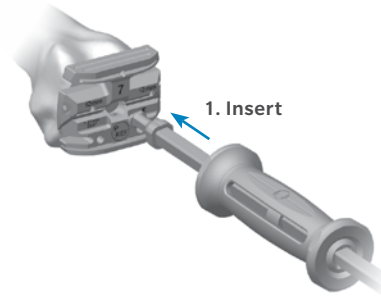

Figure 9a

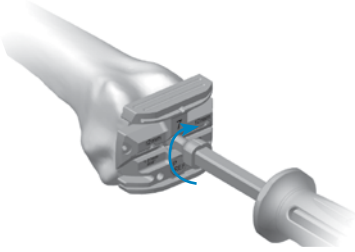

Figure 9b

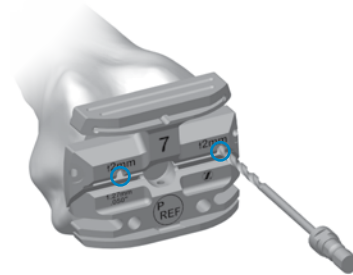

Figure 10a

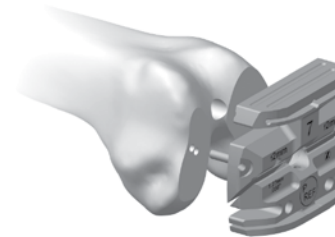

Figure 10b

Complete Femoral A/P and Chamfer Resections

By hand, place the 4-in-1 cut guide on the femur by aligning the two pegs on the back of the guide with the previously drilled positioning holes (Figure 7).

Impact the face of the guide until the guide is flush with the femur. Place the resection guide through the anterior slot of the cut guide to ensure the desired anterior resection (Figure 8).

If there is a risk of unacceptable notching the anterior cortex, use the slaphammer to axially remove the cut guide (Figures 9a & 9b). Place the next larger-sized femoral cut guide on the femur and recheck the anterior resection level with the resection guide.

If the posterior resection is insufficient/tight flexion, the cut guide can be shifted 2 mm anteriorly by drilling through the two holes marked “↑ 2 mm”. Remove the original cut guide, and place the next smaller sized femoral cut guide into the “anteriorized” holes in the femur (Figure 10a & 10b). Downsizing in combination with the anterior shift will leave the anterior resection level unaltered. Verify the final resection levels using the resection guide.

ⓘ Technique Tip: If the 2 mm shift holes are to be used, assure that the desired holes on the distal femur are used. The resection guide can be used as final verification of the anticipated anterior and posterior resections.

Persona Posterior Referencing
4-in-1 Cut Guide - Size 7
42-5099-044-62



Resection Guide
00-5977-084-00



3.2 mm Drill
00-5120-085-00



Persona Slaphammer
42-5099-037-00



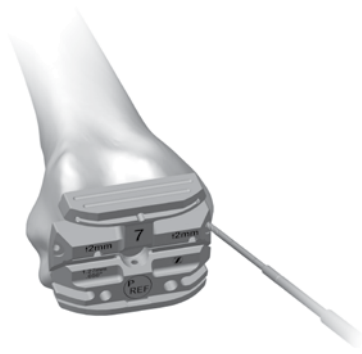

Figure 11

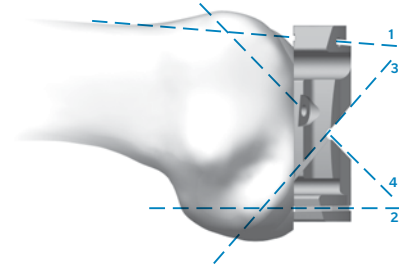

Figure 12

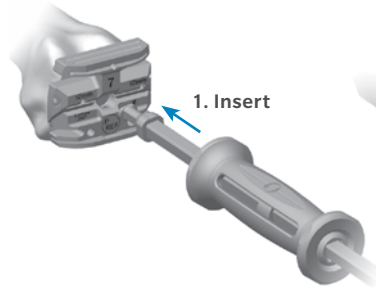

Figure 13a

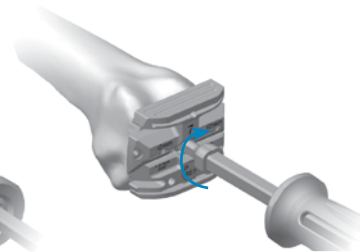

Figure 13b

Optional Instrument

The shift block can be used to internally or externally rotate the 4-in-1 cut guide two degrees and/or shift 1 mm in the anterior or posterior directions. Refer to Surgical Technique 97-5026-001-00 Appendix C: Optional Instruments: Shift Block, for use.

After final placement of the desired posterior referencing 4-in-1 cut guide, insert 3.2 mm trocar-tipped pins or 3.2 mm headed screws (see Screw/Pin Information Section for examples) through the oblique holes in the posterior referencing 4-in-1 cut guide (Figure 11).

ⓘ Technique Tip: It is not recommended that the following headed screws are used through the oblique holes of the posterior referencing 4-in-1 cut guides, as the head of the screw may interfere with the saw blade: 00-5791-041-00, 00-5791-043-00, 00-5791-044-00, 00-5061-063-00.

Use a 1.27 mm (.050 in.) thick oscillating saw blade to complete the anterior, posterior, posterior chamfer, and anterior chamfer resections through the cut slots (Figure 12). Upon completion of the cuts, use the multi pin puller or pin/screw inserter to remove the oblique pins. Use the Persona slaphammer to remove the cut guide from the femur insert slaphammer rotate ¼ turn clockwise to engage the locking feature extract (Figures 13a & 13b).

ⓘ Technique Tip: Completing the femoral resections in the order of anterior, posterior, posterior chamfer, and then anterior chamfer, the 4-in-1 cut guide will have the greatest stability.

3.2 mm x 75 mm Trocar Tipped
Drill Pin (2.5 mm Hex)
00-5901-020-00



Pin/Screw Inserter
00-5901-021-00



Multi Pin Puller
00-5901-022-00



Persona Slaphammer
42-5099-037-00



Persona Shift Block
42-5099-085-10



This documentation is intended exclusively for physicians and is not intended for laypersons.

Information on the products and procedures contained in this document is of a general nature and does not represent and does not constitute medical advice or recommendations. Because this information does not purport to constitute any diagnostic or therapeutic statement with regard to any individual medical case, each patient must be examined and advised individually, and this document does not replace the need for such examination and/or advice in whole or in part.

Please refer to the package inserts for important product information, including, but not limited to, contraindications, warnings, precautions, and adverse effects.

©2016 Zimmer Biomet



ZIMMER BIOMET

Your progress. Our promise.™



Legal Manufacturer

Zimmer, Inc
1800 West Center Street
Warsaw, IN 46581-0708
USA

97-5026-081-00-REV0616

zimmerbiomet.com