

Trabecular Metal™ Total Ankle

Surgical Technique

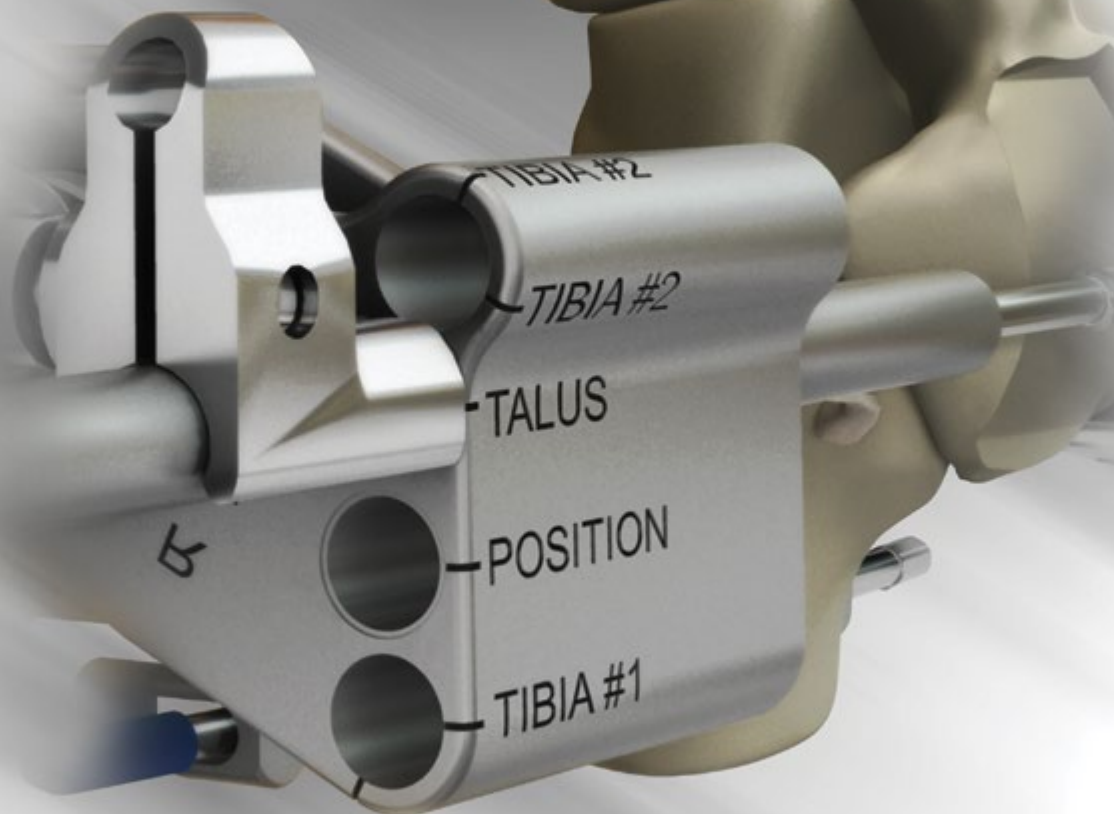

Table of contents

Surgical Technique Summary	2
Preoperative Planning	4
Exposure and Sizing	5
Alignment and External Fixation	9
Sizing and Positioning	19
Bone Preparation	24
Rail Hole Preparation	36
Trial Reduction	43
Implant Insertion	46
Repair and Closure	53
Postoperative Protocol	54
Poly Revision Procedure	55
Appendix A	59
Indications and Contraindications	66

The following general Surgical Technique Guide is for illustrative purposes only. As with all surgical procedures, the technique used in each case will depend on the surgeon's medical judgment as to the best treatment for each patient. Only those individuals with specialized training and experience in foot and ankle surgery should attempt to use the Trabecular Metal™ Total Ankle. Detailed preoperative clinical and diagnostic evaluation followed by carefully executed surgical technique is essential.

Zimmer Biomet does not practice medicine. Each physician should exercise his or her own independent judgment in the diagnosis and treatment of an individual patient, and this information does not purport to replace the comprehensive training physicians have received.

Refer to the package insert for a complete list of prescribing information, including indications, contraindications, warnings, precautions, potential adverse effects, and patient counseling information.

Surgical Technique Summary

Preoperative Planning



Fig. 2

The patient should be preoperatively assessed for joint alignment and for optimal implant size. The estimated size will later be confirmed intraoperatively.

Exposure and Sizing

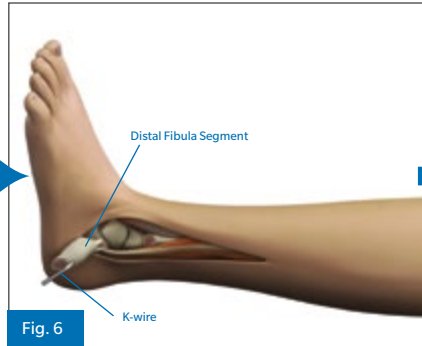

Fig. 6

Perform lateral incision and oblique osteotomy of the fibula, reflecting posteriodistally.

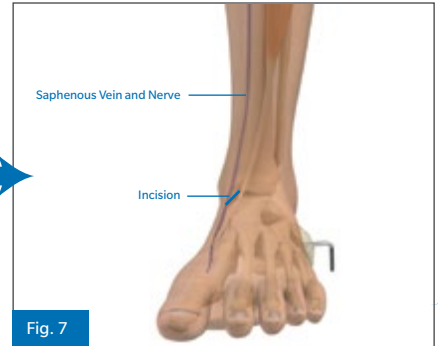

Fig. 7

Expose the medial gutter through anteriomedial arthrotomy.

Alignment and External Fixation

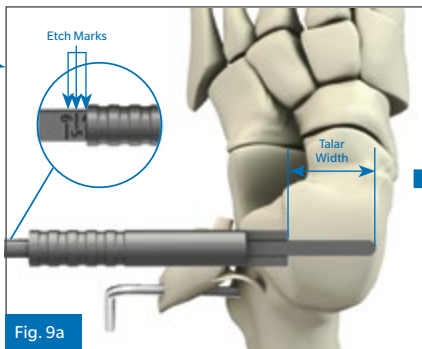

Fig. 9a

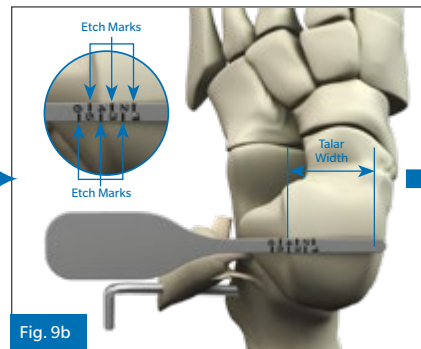

Fig. 9b

Determine largest size M/L Sizer Gauge without overhang.

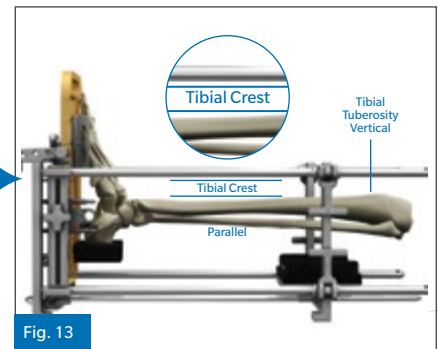

Fig. 13

Center and align joint in sagittal plane.

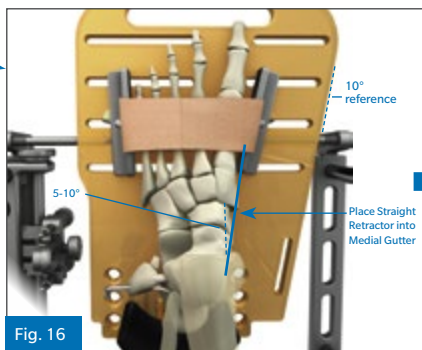

Fig. 16

Align talus and tibia in transverse plane.

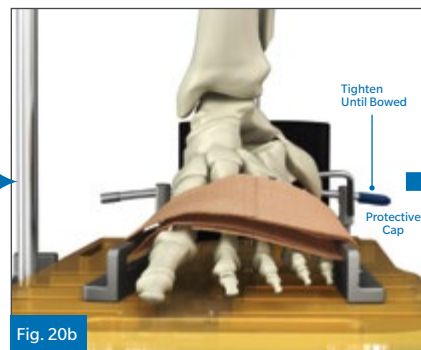

Fig. 20b

Fix foot to alignment stand with transcalcaneal pin and talar neck pin.

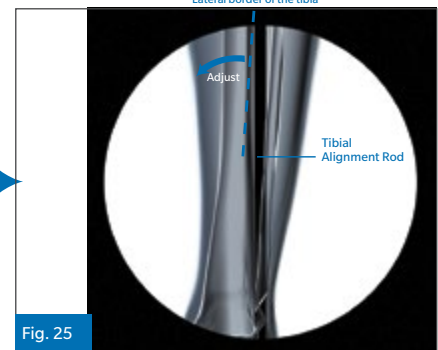
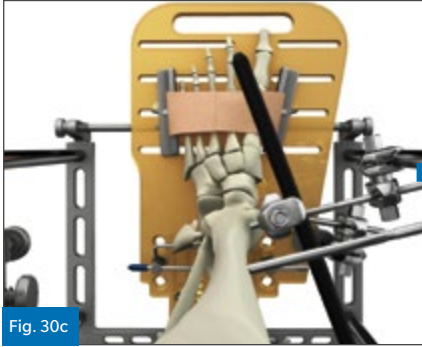

Fig. 25

Align tibia in coronal plane.

Sizing and Positioning



Fix tibia to Alignment Stand.

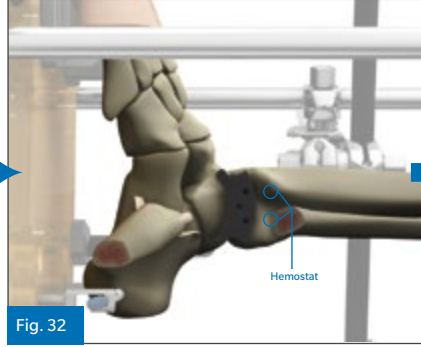

Determine final implant size from A/P coverage.



Position cutting guide at anatomic center of rotation.

Bone Preparation

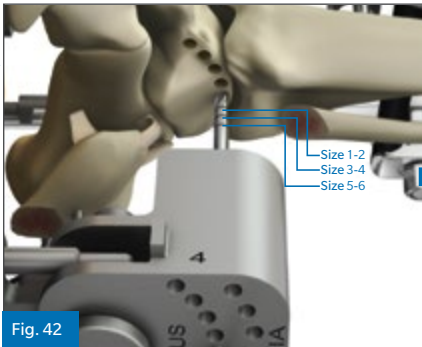

Perforate bone for selected implant size.

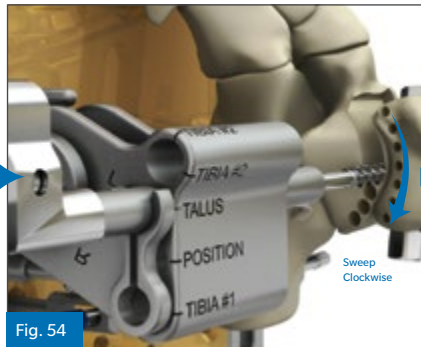

Remove bone using the provided Bur.

Rail Hole Preparation

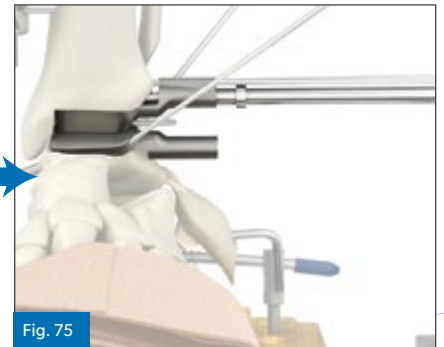

Drill rail holes for the implants.

Trial Reduction

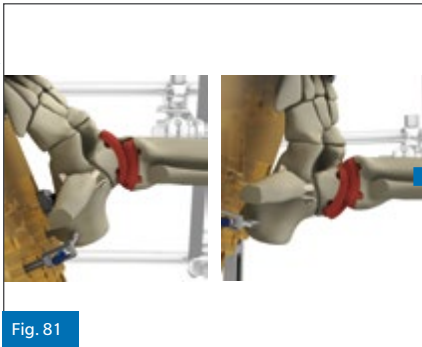

Perform trial reduction and range of motion.

Implant Insertion

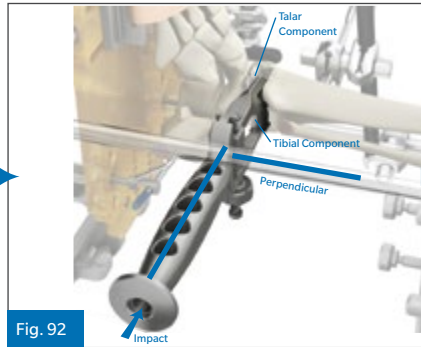

Insert final implants.

Repair and closure



Repair the fibula and close all wounds.

Surgical Technique

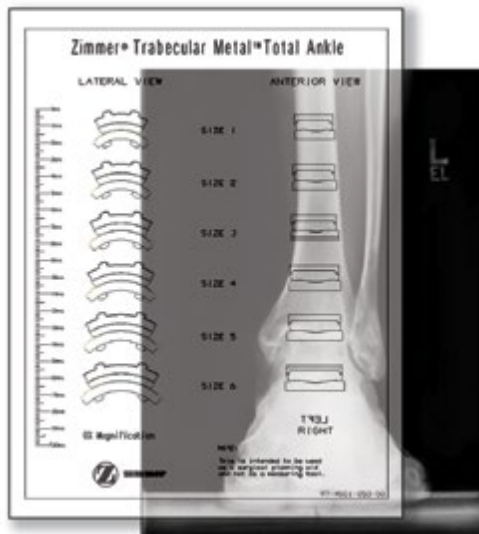

Fig. 1a



Fig. 1b

Preoperative Planning

Sizing and Alignment

Note: Prior to performing this procedure for the first time, training with a cadaver specimen is recommended.

Determine the optimal implant size for the patient (Fig. 1a & 1b).

- Overlay the sizing templates with both A/P and lateral ankle radiographs of known magnification.
- Choose the size based on maximum bone coverage with minimal overhang and talar notching.
- If unsure whether implant has overhang due to radiographic clarity, then choose the smaller size.

Note: These sizes will be confirmed by direct measurement during the procedure.

Warning: Implant sizes are NOT interchangeable.

Assess the alignment of the leg and foot.

- Up to 10° of talar tilt can be corrected by this procedure.
- Greater than 10° of talar tilt will need to be corrected prior to this procedure.

Note: Accurate alignment of the leg and foot is critical to performing this procedure and should be assessed prior to surgery. This technique assumes that all significant foot deformity, and all clinically significant deformity proximal to the ankle joint, has been corrected. Proceeding with the technique before correcting significant deformity above or below the ankle can lead to complications such as abnormal wear, subsidence, stress fracture, implant loosening, or instability. Varus/valgus malalignment in the ankle mortise can be addressed with this procedure (up to 10° of talar tilt). For valgus tilt, it may be necessary to perform a deltoid reconstruction or use a thicker implant to tension the deltoid. With both types of malalignment, the joint line should be reconstructed to be parallel to the floor in the coronal plane with the heel in the normal position, avoiding any varus alignment.

Note: This procedure requires the use of fluoroscopy. The operating room should be equipped with a radiolucent table and a full-size C-arm.

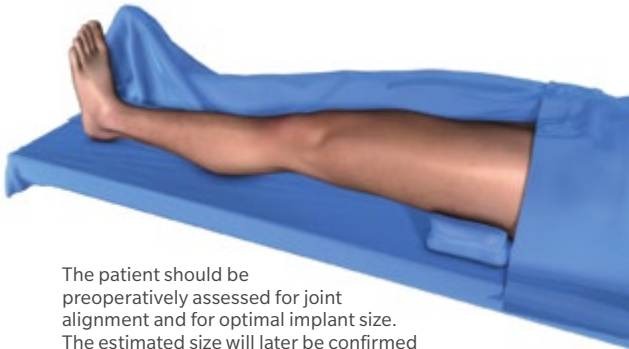

The patient should be preoperatively assessed for joint alignment and for optimal implant size. The estimated size will later be confirmed intraoperatively.

Fig. 2

Exposure and Sizing

Position Patient

Place the patient in the supine position on a radiolucent table.

Place a thick pad under the ipsilateral hip so the toes point toward the ceiling of the room (Fig. 2).

☰ **Note:** Ensure that sufficient space is available on the lateral side of the operative leg to place the Alignment Stand assembly in the center of the table. The Alignment Stand should be assembled prior to patient positioning (see Appendix A).

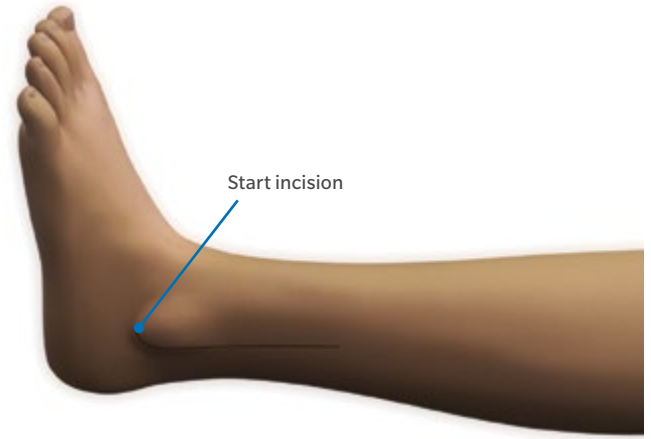

Fig. 3

Expose Joint

Make the initial incision.

- Start just below the distal tip of the fibula and extend the incision approximately 15 cm proximally (Fig. 3).
- The incision should be a few millimeters posterior to the mid-longitudinal line of the lateral malleolus.
- The leg should not be in the Alignment Stand assembly.

☰ **Note:** Ensure that the incision avoids the superficial peroneal nerve proximally and distally.

Surgical Technique

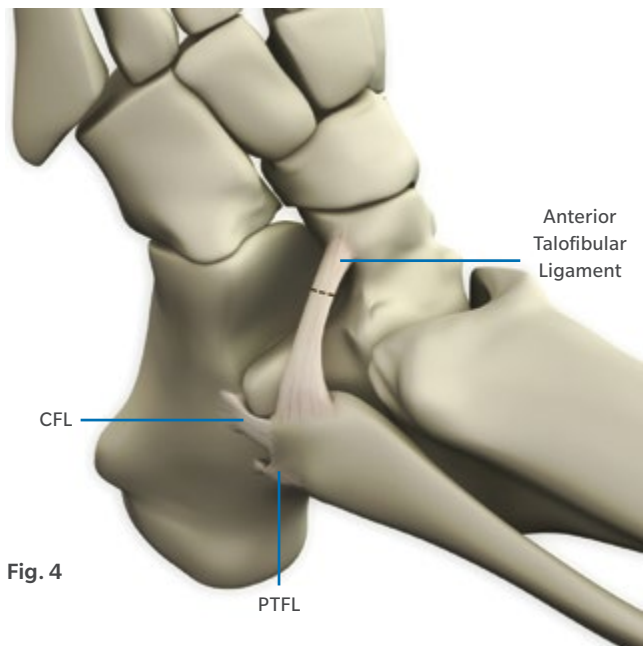

Fig. 4

Expose the lateral malleolus.

- Perform subperiosteal dissection on the lateral, anterior, and posterior surfaces of the lateral malleolus.
- Extend dissection to a distance of 1.5 cm proximal to the ankle joint.

Identify and section the anterior talofibular ligament (ATFL) (Fig. 4).

- Leave a cuff on the ATFL to repair after surgery.
 - Leave the distal fibular segment tethered by the calcaneofibular ligament (CFL) and posterior talofibular ligament (PTFL).

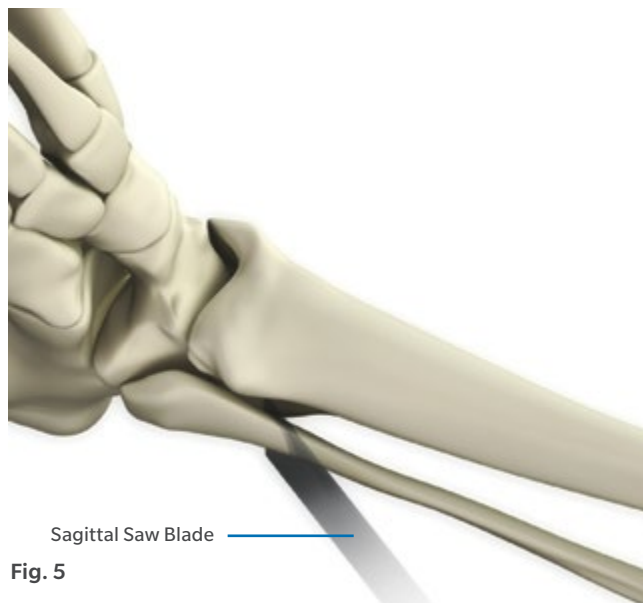

Fig. 5

Perform a fibular osteotomy.

- Use a microsagittal saw to make an oblique osteotomy from superolateral to inferomedial.
- Start the osteotomy 2.5 cm-3.0 cm proximal to the joint line, and end it 1.0 cm-1.5 cm proximal to the joint line (Fig. 5).
- If there is any uncertainty about the location of the joint line, use fluoroscopy to confirm the level of the osteotomy.

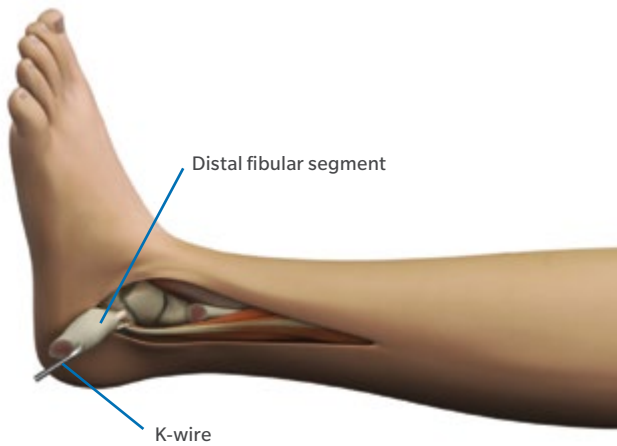

Fig. 6 Perform lateral incision and oblique osteotomy of the fibula, reflecting posteriodistally.

Reflect the distal fibular segment.

- Place a periosteal elevator in the lateral gutter to pry and dissect tissue.
- Insert a bone hook in the distal portion of the osteotomy and reflect the lateral malleolus posteriodistally until the joint can be fully visualized.
 - Perform a blunt dissection of the medial surface of the distal fibular segment.
 - Fully release the syndesmodic/ tibiofibular ligaments from the distal fibular segment to allow reflection.
- Leave the distal fibular segment tethered by the calcaneofibular ligament (CFL) and posterior talofibular ligament (PTFL).

Caution: Be careful to avoid overstressing the PTFL and CFL.

Instruments



1.6 mm K-wire
00-4501-040-01

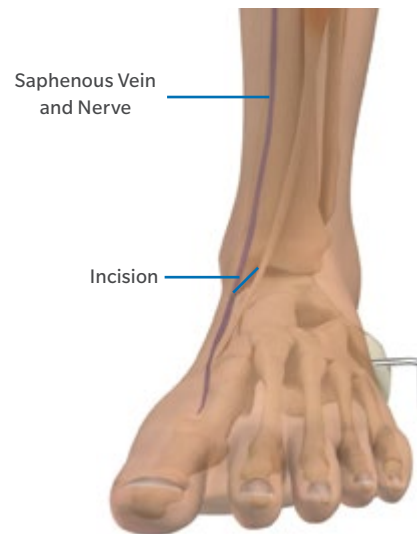

Fig. 7 Expose the medial gutter through anteriomedial arthrotomy.

Pin the distal fibular segment to the Calcaneus.

- Pin the fibula against the foot with a 1.6 mm K-wire (Fig. 6).

Bend the wire posteriorly and away from the ankle joint.

Expose the medial gutter of the ankle joint.

- Incision should be approximately 3 cm-4 cm in length, over the medial gutter and medial to the anterior tibial tendon (Fig. 7).

Caution: Be careful not to damage the greater saphenous vein and nerve.

Release the ankle joint.

- Remove osteophytes from all surfaces to allow for joint range of motion.
- Use a blunt instrument to release the anterior and posterior capsule.
- Palpate medially across the anterior and posterior aspects of the ankle to ensure that the release is complete.
- Place the foot and ankle in a neutral position.

Note: If equinus (plantar flexion contracture) is present after removing bony blocks to motion, consider a gastrocnemius recession or Achilles lengthening.

Surgical Technique



Fig. 8 Insert M/L Sizer Gauge to medial edge of talus.

Determine M/L Size

Assess maximum implant size without lateral overhang. The Trabecular Metal™ Total Ankle Instrument System provides two sizer options, the M/L Sizer Gauge and the M/L Sizer. Selection of type of sizer instrument is based on surgeon preference.

- Insert the Medial/Lateral Sizer Gauge or Sizer between the articular surfaces of the tibia and talus at the top of the talar dome.
- Push the Sizer Gauge or sizer across the joint medially until it is at the medial edge of the talus.
- If necessary, manipulate the joint to prevent binding of the sizer gauge or sizer in the joint space.
- Confirm sizer gauge or sizer position with fluoroscopy (Fig. 8).
- Slide sizer gauge barrel or sizer until extension tip contacts the lateral talus.

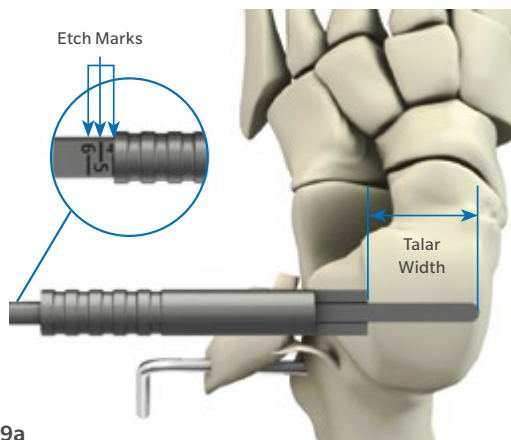

Fig. 9a

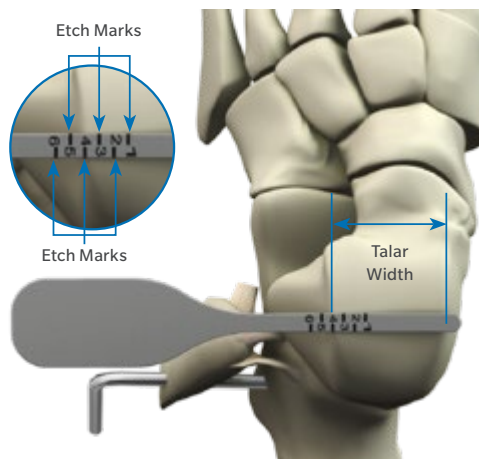

Fig. 9b Determine largest size M/L Sizer Gauge without overhang.

- Visually assess talar width to determine the largest allowable implant size that can be seated in the joint without any M/L overhang (Fig. 9a, 9b).
 - If talus width is between two sizes, choose the smaller size so as to reduce likelihood of overhang.
- Note:** The size determined in this step will be used in conjunction with that found with the Anterior/Posterior Sizer to determine the appropriate implant size (see Alignment and External Fixation).

Instruments



M/L Sizer Gauge
00-4501-048-07



M/L Sizer
00-4501-048-00

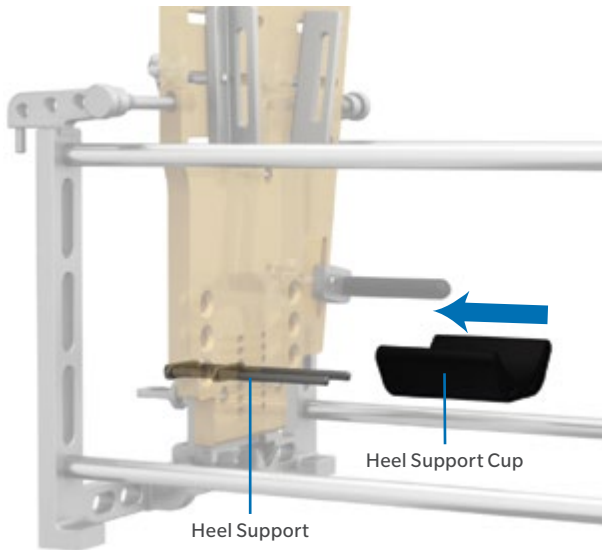

Fig. 10

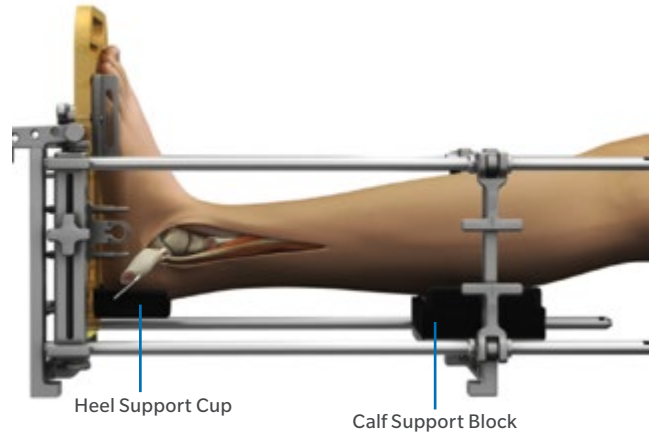

Fig. 11

Alignment and External Fixation

Align the Joint

Note: All significant foot deformity and all clinically significant deformity proximal to the ankle joint must be corrected before proceeding with this procedure.

Place the Alignment Stand on the operating table.

Attach the Heel Support Cup to the Alignment Stand.

- Insert the shafts of the Heel Support through the appropriate Heel Support Holes, from the backside of the Foot Plate.
- Slide the Heel Support Cup over the shafts from the inside of the Foot Plate (Fig. 10).

Place the leg in the Alignment Stand assembly (Fig. 11).

- The heel should rest on the Heel Support Cup.
- Adjust the position of the Heel Support Cup so that the ankle joint is centered between the alignment rods in a lateral view.
- The calf should rest on the stack of Calf Support Blocks.

Instruments



Alignment Stand
Assembly



Heel Support
00-4501-052-00



Heel Support Cup
00-4501-052-03

Surgical Technique

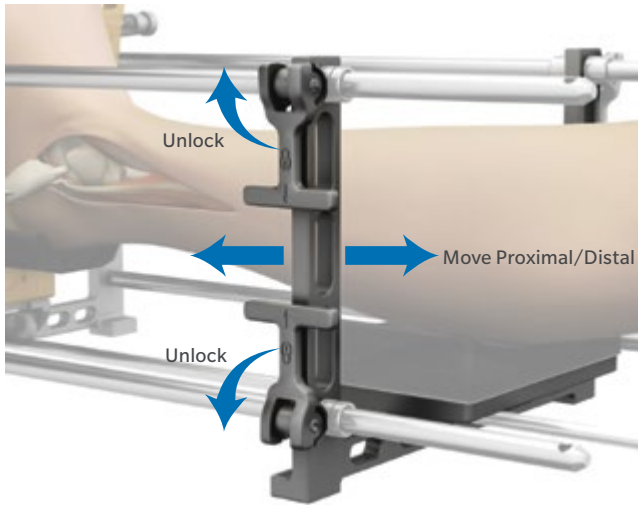

Fig. 12

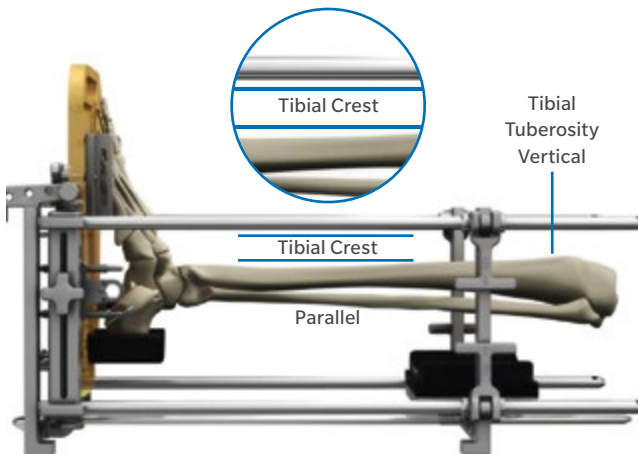

Fig. 13 Center and align joint in sagittal plane.

Adjust Calf Block Supports.

- Unlock the four lever fasteners on the U-frame component on the proximal end of the Alignment Stand assembly and slide proximally or distally along the longitudinal Frame Rods until it is in position directly under the mid to proximal calf. Then relock the lever fasteners (Fig. 12).
- Add or remove Calf Support Blocks so the tibial crest is parallel to the longitudinal Frame Rods (Fig. 13).
- Rotate the tibia so that tibial tuberosity is vertical.



Fig. 14



Fig. 15

Position the Foot Plate Brackets to the level of the MTP joints.

- Adjust the Foot Plate Brackets so that they contact the foot at the medial first and lateral fifth metatarsophalangeal (MTP) joints (Fig. 14).
- Be sure that the Foot Plate Brackets are attached at the appropriate slots in the Foot Plate.

Secure foot to the Foot Plate.

- Feed the self-adhesive elastic wrap loosely through the Foot Plate Brackets and over the top of the foot (Fig. 15).

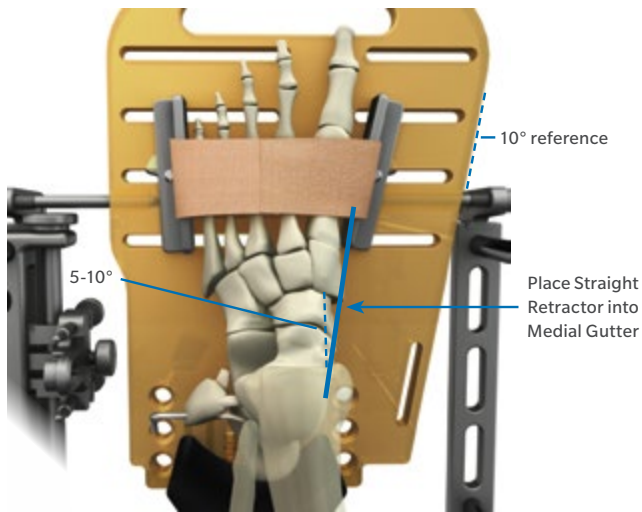

Fig. 16 Align talus and tibia in transverse plane.

Establish proper alignment in the foot.

- Rotate the leg/ankle so that the plane of the medial clear space is angled 5° to 10° medially from vertical (Fig. 16).
- Verify by placing a straight malleable retractor into the incision site over the medial clear space. This ensures that the trochlea of the talus is properly aligned within the frame.
- In addition, assessment of the talar alignment can be determined by placing the blunt end of the Center Probe through any Cut Guide against the lateral facet of the talus comparing parallelism between the blunt end of the Center Probe.

⊞ **Note:** All significant foot deformity and all clinically significant deformity proximal to the ankle joint must be corrected before proceeding with this procedure.

Instruments



Malleable Retractor
00-4501-080-00



Center Probe
00-4501-056-00

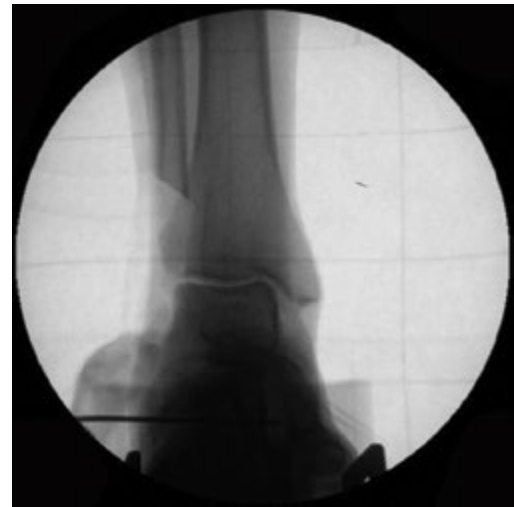

Fig. 17

Secure forefoot to Foot Plate.

- Tighten the Foot Plate Brackets after proper alignment is achieved.
- Ensure the Self-Adhesive wrap is secure around the foot.

⊞ **Note:** The foot should be visible through the translucent Foot Plate to assess loading of the heel and metatarsal heads. If the foot does not rest flush against the Foot Plate in the coronal plane, (i.e., varus or valgus), deformity correction may be required before continuing. Perform this correction at the level of deformity, (i.e. hindfoot deformity at the subtalar joint or calcaneus and midfoot deformity at the midfoot joints).

Assess tibiotalar alignment using fluoroscopy.

- Assess proper joint congruency (Fig. 17).
- Ensure varus/valgus mal-alignment is corrected.
- Obtain a mortise view in order to ensure proper axial alignment.

Surgical Technique

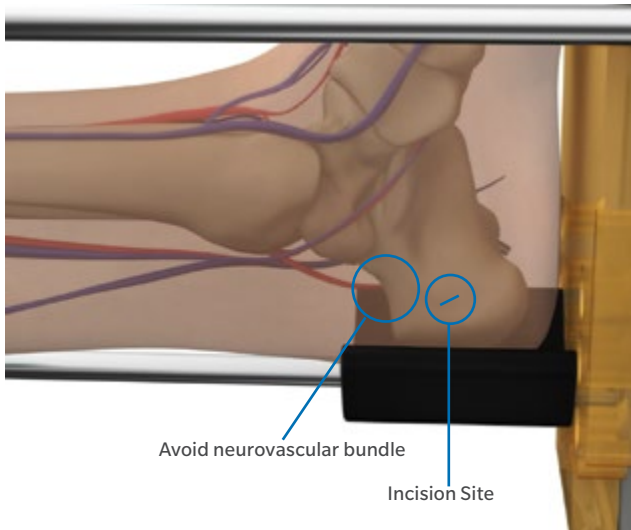

Fig. 18

Perform External Fixation

Transcalcaneal Fixation

Drill Calcaneus Pin transversely through the calcaneus.

- Make a small incision prior to pin insertion approximately 2.5 cm from the posterior heel and 2.5 cm from the distal heel (Fig. 18).
- Spread the tissues at the medial incision site and insert a Drill Sleeve into the incision.

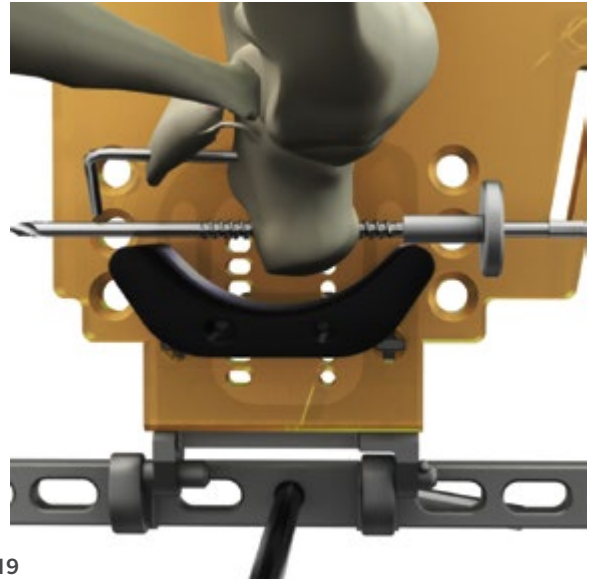

Fig. 19

- Drill the Calcaneus Pin through the calcaneus using the Drill Sleeve (Fig. 19).
 - Ensure the pin is inserted parallel to both the Foot Plate and to the table.
 - Pin insertion can be performed under fluoroscopy to ensure correct placement.
- Remove the Drill Sleeve.

Caution: Be careful to avoid the neurovascular bundle.

Instruments



Calcaneus Pin
00-4501-040-00



Drill Sleeve
00-4501-041-00

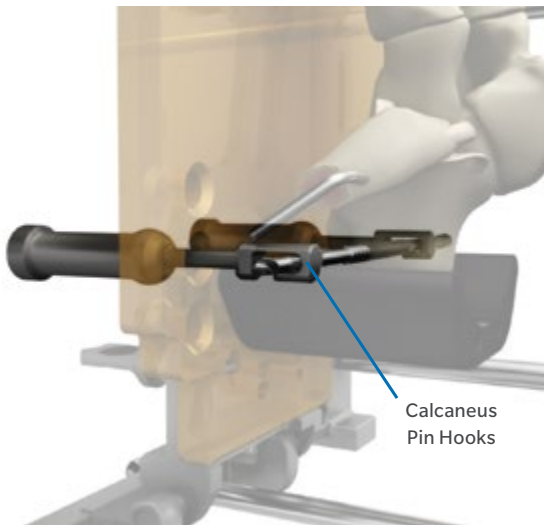

Fig. 20a

Attach Calcaneus Pin to Foot Plate using the Calcaneus Pin Hooks.

- Assemble Calcaneus Pin Hooks.
- Insert Calcaneus Pin Hooks in the appropriate holes in the Foot Plate.
 - The hooks should engage on the pin without applying an upward or downward force (Fig. 20a).
- Simultaneously tighten both Calcaneus Pin Hooks until the Calcaneus Pin slightly bends (Fig. 20b).
 - The heel should be firmly pulled back against the Foot Plate.
 - A plantar view of the foot should be visible through the Foot Plate (Fig. 21).

Instruments



Calcaneus Pin
Hook Fastener
00-4501-052-01



Calcaneus Pin Hook
00-4501-052-02

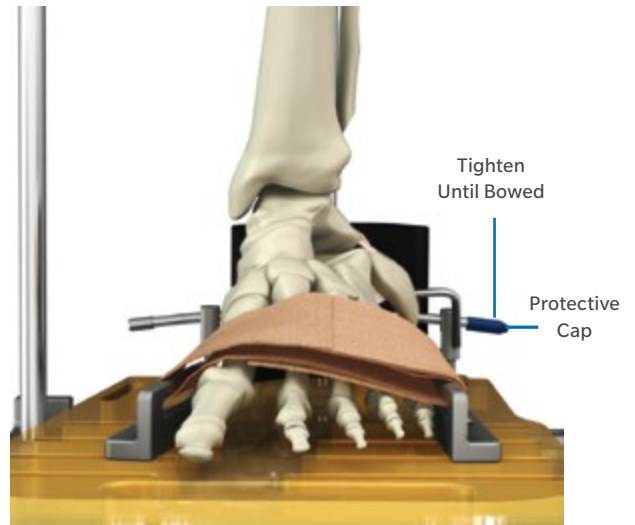

Fig. 20b



Fig. 21

- Even pressure along the plantar surface of the foot should be visible. When correcting varus or valgus alignment of the rearfoot, uneven tensioning of the Calcaneus Pin Hooks can be applied to assist in correcting these bony deformities.
- Place protective cap over drill end of Calcaneus Pin.
- **Note:** Confirm that Calcaneus Pin Hooks are adequately tightened.

Surgical Technique

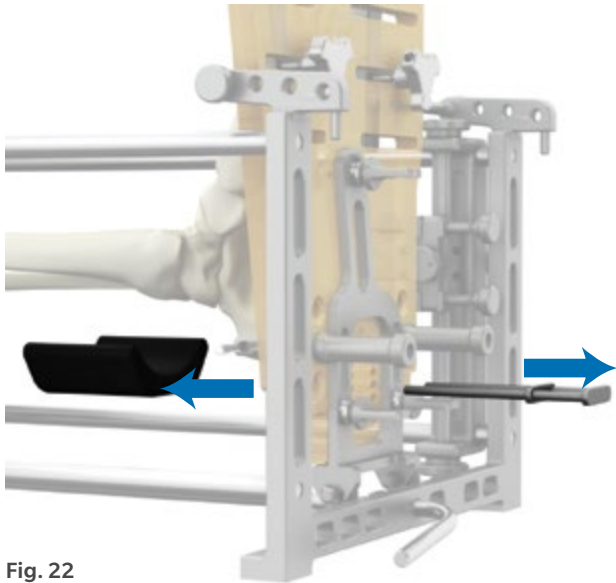

Fig. 22

Remove Heel Support and Heel Support Cup (Fig. 22).

Talar Fixation

Attach Pin-to-Rod Clamp to the Talar Pin Connector on the Foot Plate.

- Slide it over the proximal end of the Talar Pin Connector so that the clamp is as close to the foot and is distal to the talar body.
- Adjust the position of the Talar Pin Connector on the Foot Plate and the clamp on the arm so that a pin can be inserted through the clamp and into the talar neck (Fig. 23).
- The clamp should be centered to the body of the calcaneus to minimize interference with the ankle joint during fluoroscopy.

Make a small incision on the talar neck for pin insertion (Fig. 23).

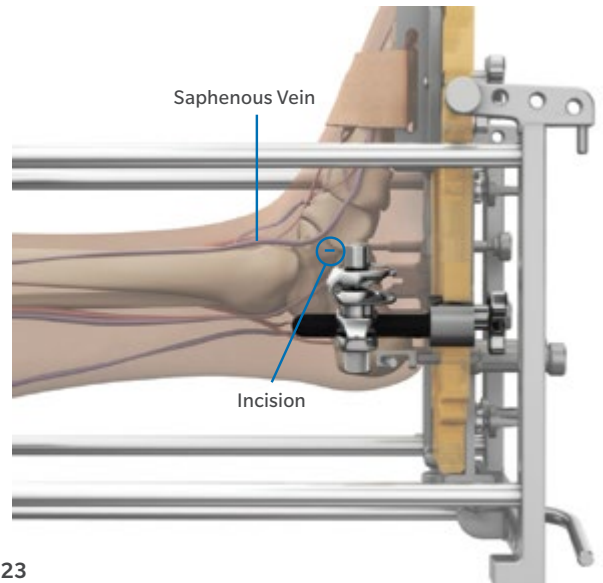

Fig. 23

- Approximately 1.0 cm anterior and 1.0 cm distal to the tip of the medial malleolus.
- Superior/dorsal to the tarsal tunnel.
- Posterior to the saphenous vein.
- Between the anterior and posterior tibial tendons.

Instruments



Pin-to-Rod Clamp
and Fastener
00-4501-050-05
00-4501-050-06

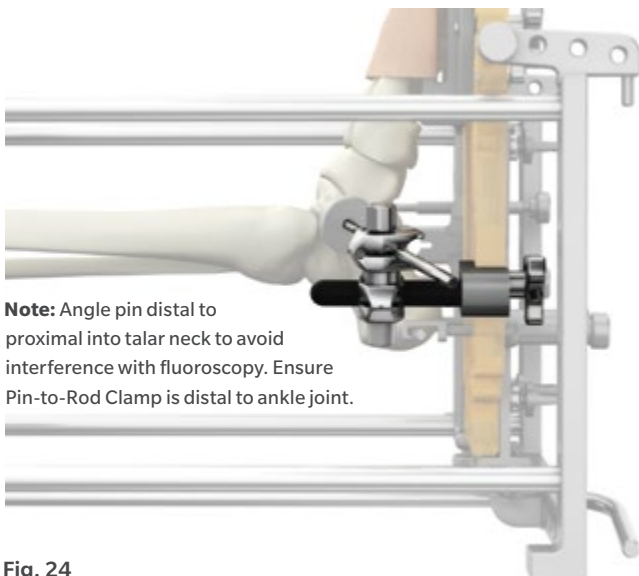

Fig. 24

Secure the Talus to the Foot Plate.

- Drill the 4.0 mm Pin through the clamp and the Drill Sleeve into the incision at the talar neck, achieving unicortical fixation (Fig. 24).
- Use fluoroscopy to help identify the optimal insertion site.
- The pin should be angled from distal to proximal to minimize potential interference during fluoroscopy.
- Tighten the Pin-to-Rod Clamp fasteners to the Talar Pin Connector using the Wrench.
- The Drill Sleeve may be left on the pin.

Instruments

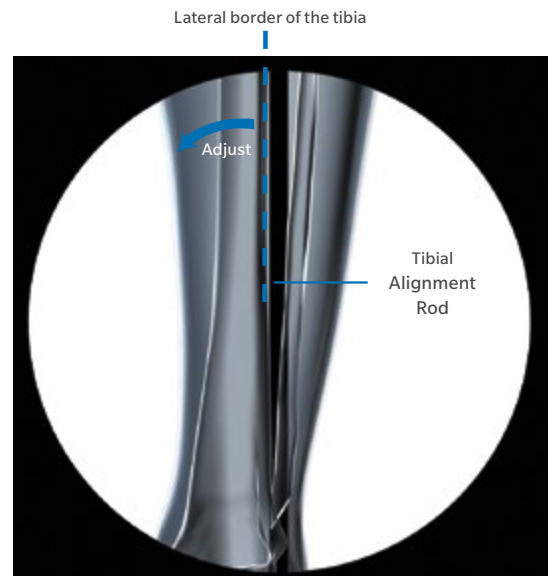

Fig. 25 Align tibia in coronal plane.

Tibial Fixation

Verify Tibial Alignment.

- Use fluoroscopy to verify that the tibia is aligned in the correct relationship to the Tibial Alignment Rod (Fig. 25).
- Without deformity, the Tibial Alignment Rod should be parallel to the lateral border of the tibia at mid-shaft in an A/P view.
- Without deformity, the tibial crest should be parallel to the longitudinal Frame Rods in an M/L view.
- The talus should be congruent with the distal tibia in an M/L view.
- The Center Probe, when placed through any Cut Guide, can be used to help with tibial alignment. While resting the Center Probe across the anterior tissues, a fluoroscopy image can be utilized to visualize the proper alignment of the joint line and lateral border of the tibia.

Surgical Technique

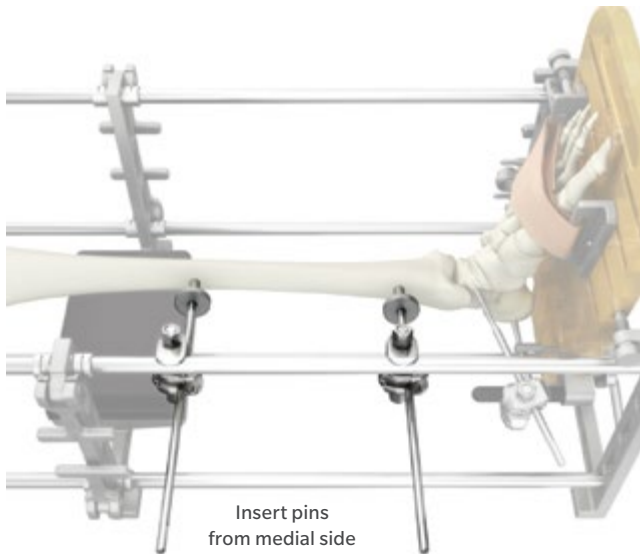

Fig. 26

Standard Configuration

Fix the Tibia to the Frame Rods of the Alignment Stand.

- Insert two 5.0 mm Self Drilling Pins on the medial side of the tibia (Fig. 26).
- Use the same method used for talar fixation (i.e., small incision, drill sleeves, drill through clamps).
- The pins should be located approximately 20 cm and 5 cm proximal to the joint line.
- The pins should be attached to clamps on the upper medial Frame Rod and centered between the subcutaneous anterior and posterior borders of the tibia.
- Drill Sleeves can be left on the pins.
- Unicortical insertion is recommended unless bone quality is poor.
- Tighten all clamps using the Wrench.

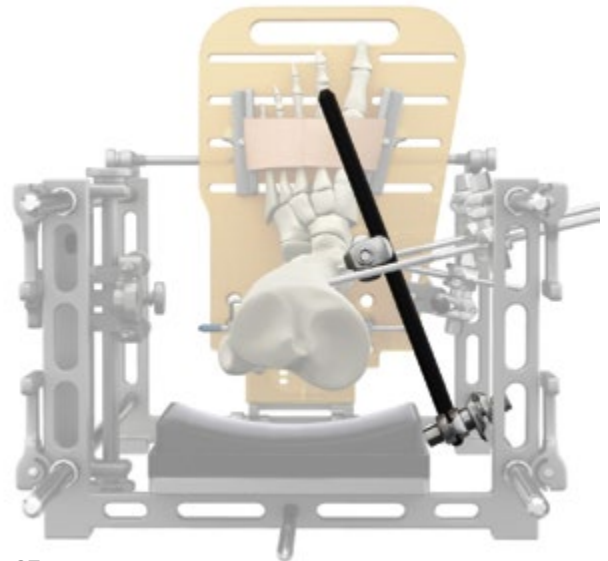

Fig. 27

- **Technique Tip:** To maintain proper sagittal congruency, have an assistant hold the tibia in place during pinning.

Enhance the rigidity of tibial fixation using the Carbon Fiber Rod.

- Place a Pin-to-Rod Clamp on the distal tibial pin, near the leg.
- Place another Pin-to-Rod Clamp on the outside of the lower medial Frame Rod.
- Position the Carbon Fiber Rod through the clamps and tighten (Fig. 27).

Instruments



5.0 mm Pin (2)
00-4501-040-05



Drill Sleeve (2)
00-4501-041-00



Pin-to-Rod Clamp
and Fastener (4)
00-4501-050-05
00-4501-050-06



Carbon Fiber Rod
00-4501-050-07



Wrench
00-4450-075-00

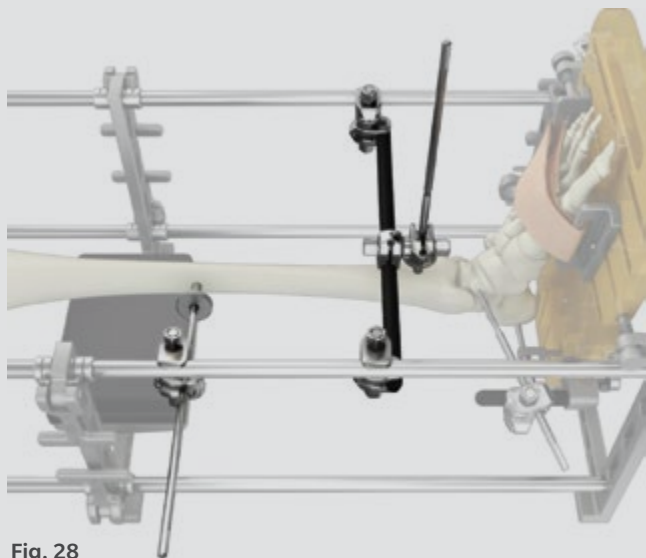

Fig. 28

Alternate Configuration

Insert one 5.0 mm Self Drilling Pin into the anterior portion of the distal tibial metaphysis approximately 5 cm above the joint line.

Use the same method used for the talar fixation (i.e. small incision, Drill Sleeve, drill through Pin-to-Rod Clamp) (Fig. 28).

Note: Take care to not disturb the anterior soft tissue structures.

Once inserted, the 5.0 mm Self Drilling Pin can be used to help address sagittal alignment of the tibia.

Use the Carbon Fiber Rod to span the upper Frame Rods using two Pin-to-Rod Clamps.

Attach the 5.0 mm Self Drilling Pin to the Carbon Fiber Rod using a Pin-to-Rod Clamp.

Instruments

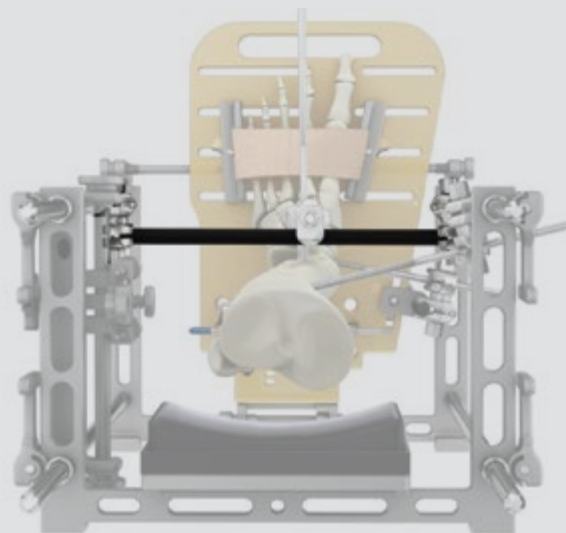

Fig. 29

The second pin should be inserted into the medial tibia approximately 20 cm above the joint line.

The pin should be attached to the clamp on the upper medial Frame Rod and centered between the subcutaneous anterior and posterior border of the tibia (Fig. 29).

Drill Sleeves can be left on the pins.

Unicortical insertion is recommended unless the bone quality is poor.

Tighten all clamps with a Wrench.

For extra stability, a second Carbon Fiber Rod can be attached to the Talar Pin, as well as the distal Tibial Pin using Pin-to-Rod Clamps.

Note: Extra Carbon Fiber Rods and Pin-to-Rod Clamps can be found in the TM Ankle Supplemental Kit (KT-4501-000-06).

Surgical Technique

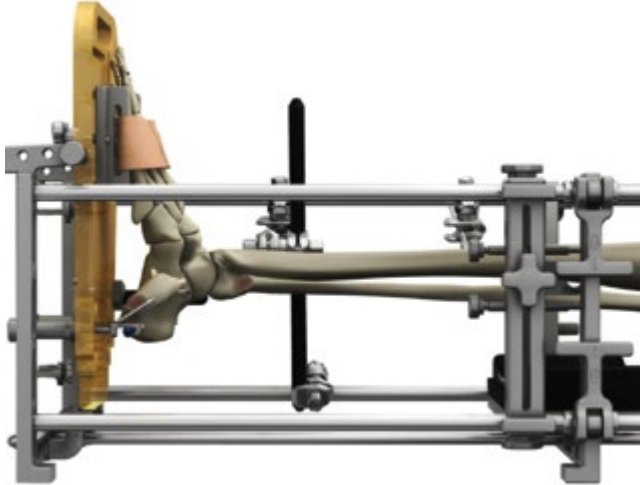

Fig. 30a

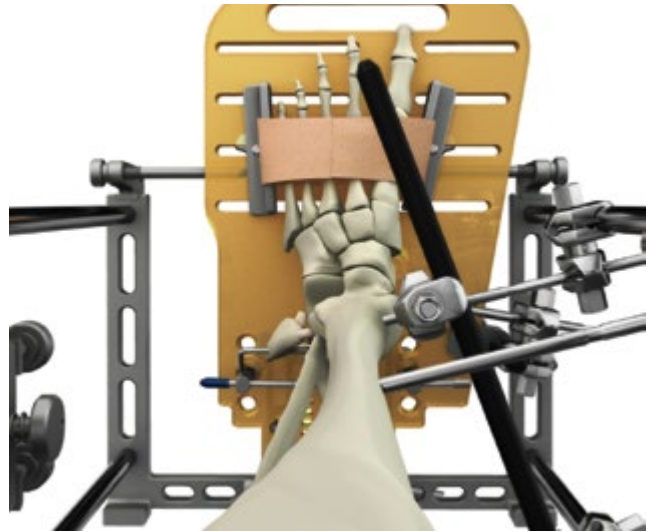

Fig. 30c

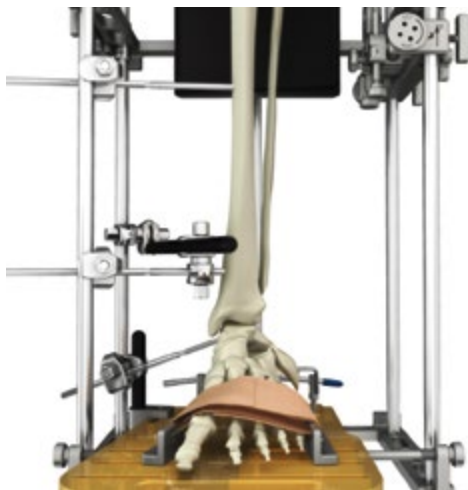

Fig. 30b

Verify proper alignment and deltoid tension.

- Manually distract the ankle joint as necessary to facilitate the correction of any varus/valgus deformity or to accommodate deltoid ligament laxity.
- Distraction can be achieved by loosening the rod side of the three proximal Pin-to-Rod Clamps from the Frame Rods.
- Retighten the clamps after achieving the proper alignment.

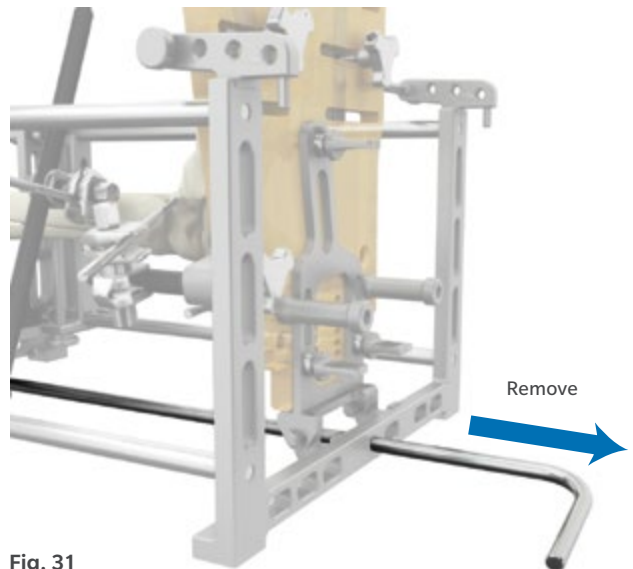

Fig. 31

Confirm final alignment with fluoroscopy and make adjustments if necessary (Fig. 30a, 30b & 30c).

Remove the Tibial Alignment Rod to reduce interference with fluoroscopy. (Fig. 31).

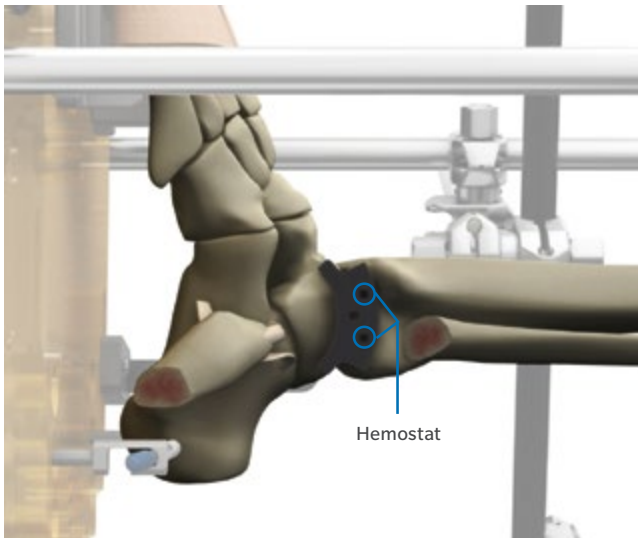

Fig. 32 Determine final implant size from A/P coverage.

Sizing and Positioning

Select size and set position.

Sizing

Confirm final implant size.

- Select the A/P Sizer based on the same size M/L Sizer.
- Use a small hemostat to hold the A/P Sizer against the lateral bone surface of the joint space to assess the resection curves and planned bone cuts for the selected size (Fig. 32).
 - Bony coverage should be maximized.
 - If there is too much A/P overhang, evaluate a smaller size.
 - In the event that the bony anatomy is between two sizes, choose the smaller size.
 - The A/P Sizer does not have to cover the tibia and talus simultaneously. The sizer can be rotated about the talus to assess each side independently.

Instruments

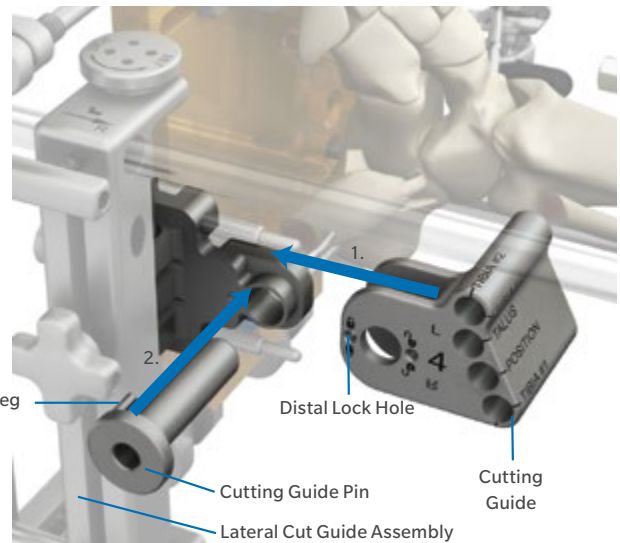

Fig. 33

- **Warning:** Talar and tibial component sizes are not interchangeable. A single size for both tibial and talar components must be chosen.
- **Caution:** Ensure that there is no M/L overhang. The size determined with the M/L Sizer is the maximum allowable size.

Positioning

Attach and initially position the Cutting Guide.

- Attach the Cutting Guide for the selected size to the Lateral Cut Guide Assembly.
- Insert the peg on the Cutting Guide Pin into the distal lock hole on the Cutting Guide (Fig. 33).
- Ensure that the Lock/Unlock symbols are facing laterally.

Surgical Technique

Rotate to adjust the Cutting Guide vertically.

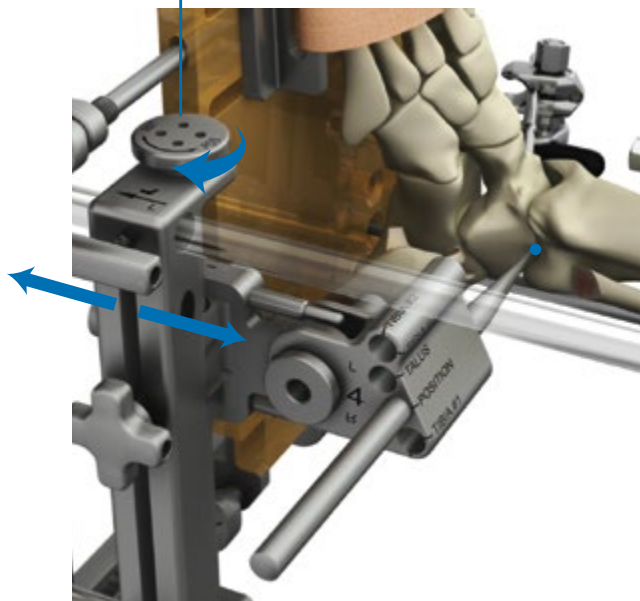

Fig. 34

- Place the Center Probe through the “POSITION” hole on the Cutting Guide.
- Adjust the Cutting Guide System so that the tip of the Center Probe contacts the lateral talus at the superior talar dome and is centered between the tibia and talus (Fig. 34).

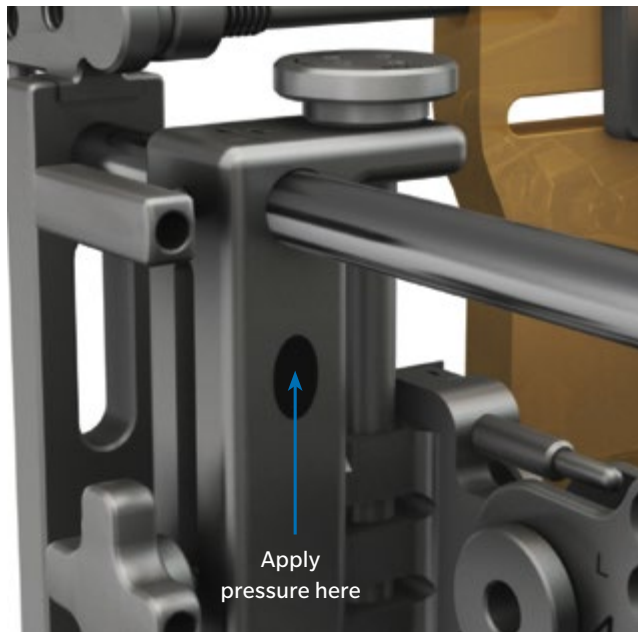

Fig. 35

- ⓘ **Note:** The Lateral Cut Guide Assembly slides best when pressure is applied at the oval etch indicated (Fig. 35).

Instruments



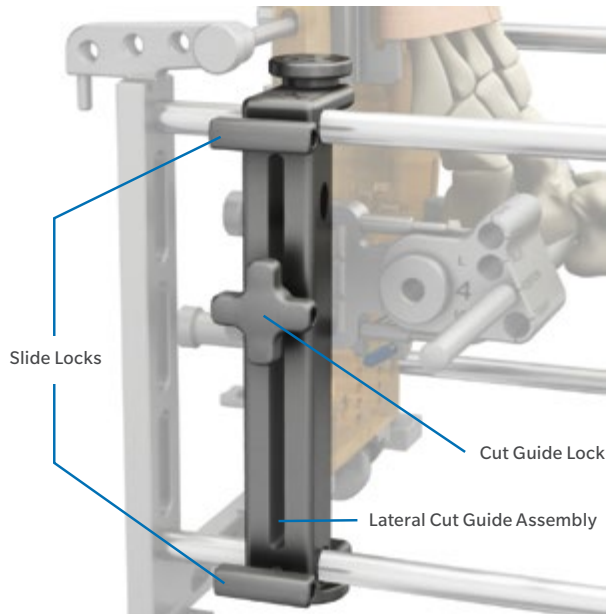

Fig. 36

Lock the Lateral Cut Guide Assembly into position.

- Tighten the Slide Locks to prevent proximal/distal movement of the Lateral Cut Guide Assembly (Fig. 36).
- Tighten the Cut Guide Lock to prevent A/P movement.

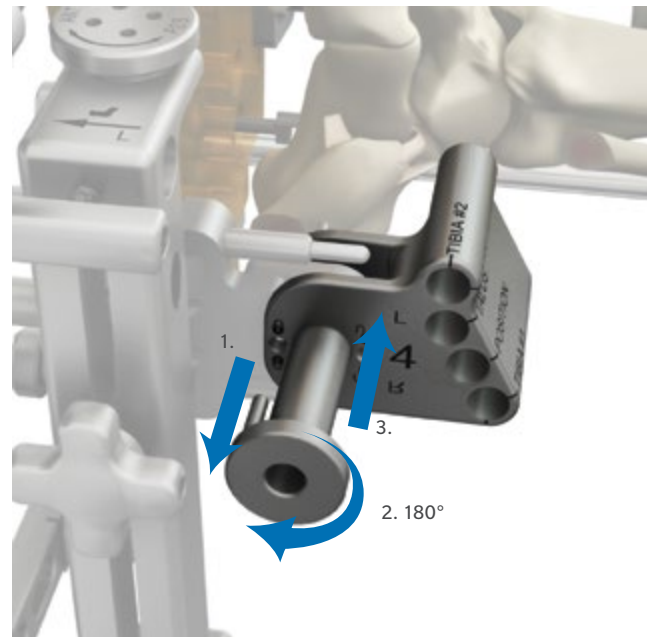

Fig. 37

Visualize the reconstructed joint line and establish final Cutting Guide Position.

- Pull the Cut Guide Pin and rotate it 180° so that the peg engages the proximal hole in the Cutting Guide (Fig. 37).

Surgical Technique

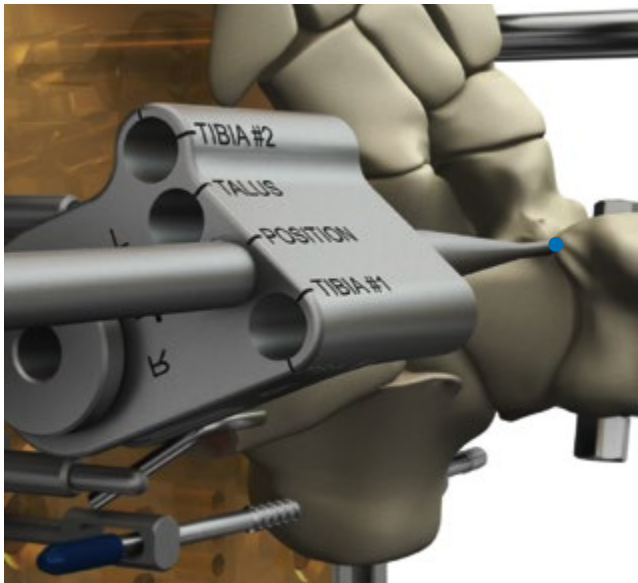

Fig. 38a

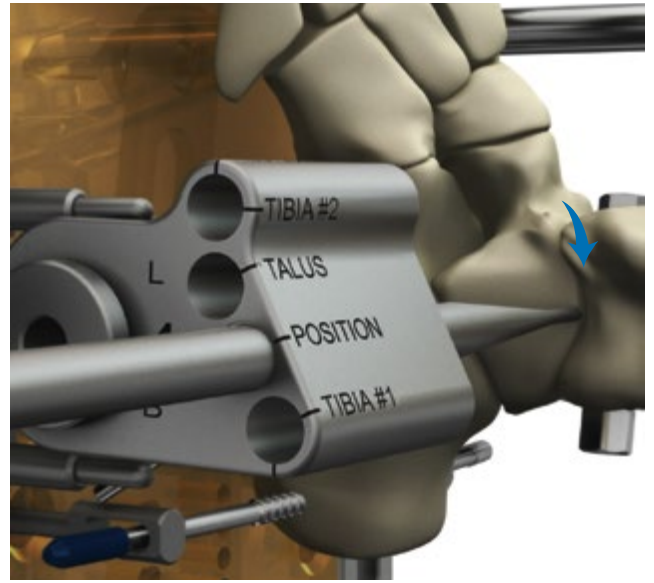

Fig. 38b

- The Cutting Guide should be free to rotate.
- Sweep the probe back and forth to assess the reconstructed joint line (Fig. 38a, 38b & 38c).



Fig. 38c Position Cutting Guide at anatomic center of rotation.

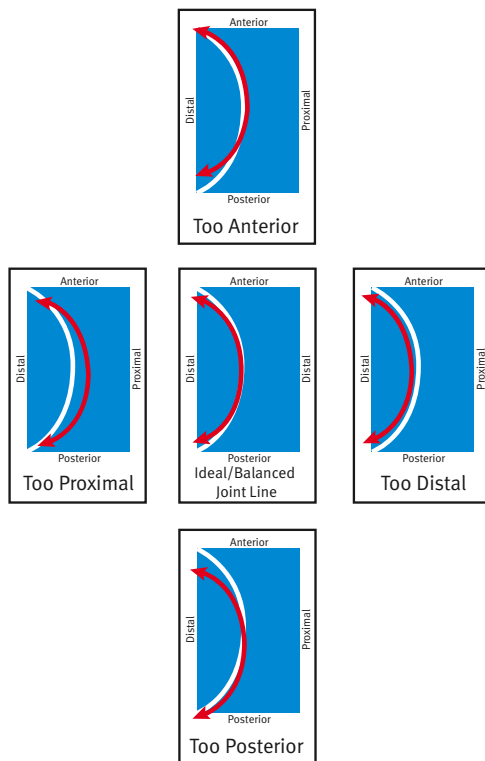

Fig 39 Red line represents the sweeping motion of Center Probe. White line represents Tibial/Talar joint line.

- Compare the center of rotation for the reconstructed joint line to the anatomic center of rotation.
- If necessary, loosen the appropriate locks on the Lateral Cut Guide Assembly and adjust the A/P and/or proximal/distal position until the probe sweep represents an appropriate joint line (Fig. 39). Retighten the locks.

Technique Tip: If abnormal anatomy makes it difficult to determine the planned joint line, the A/P Sizer can facilitate alignment. Hold the sizer against the lateral bone surface in a position that approximates the desired joint line. Align the Center Probe through the Cutting Guide to the center hole of the sizer.

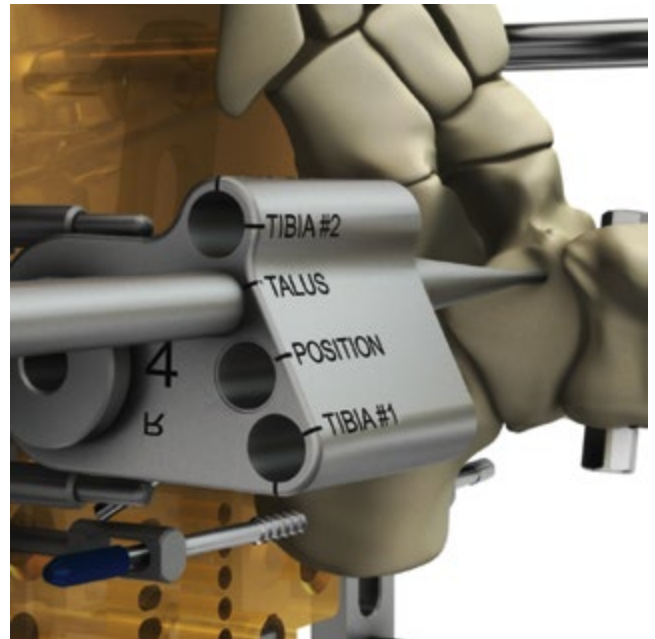

Fig. 40

Evaluate expected bone removal and adjust as desired.

- Repeat the sweep again using the “TALUS” hole to visualize the amount of talar bone that will be removed (Fig. 40).
 - Repeat the sweep with the Center Probe in the tibial hole marked “TIBIA #1” to visualize the amount of tibial bone that will be removed.
 - If too much bone will be removed from either the tibia or the talus, adjust the position of the Lateral Cut Guide Assembly.
 - Loosen the Slide Locks and slide the Lateral Cut Guide Assembly accordingly proximally or distally.
 - Carefully repeat each of the probe sweeps to confirm the location of the joint and the bone cuts.
 - Make sure all locks are completely tightened before continuing.
- Note:** The probe sweep should minimize excessive bone removal posteriorly and anteriorly, while avoiding soft tissue structures.

Surgical Technique

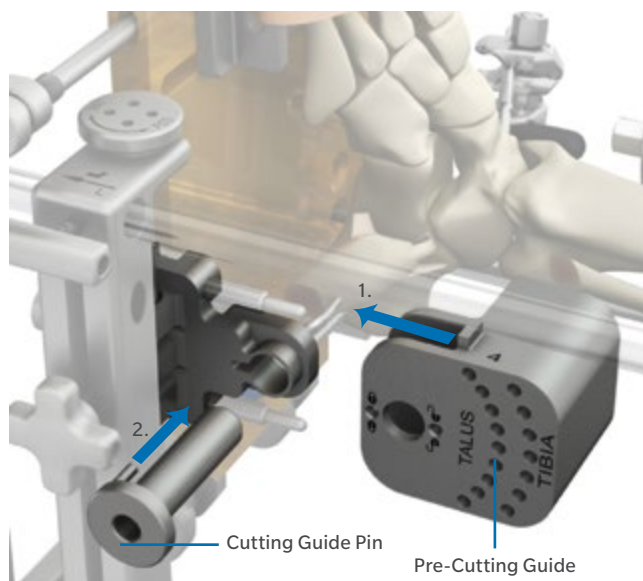

Fig. 41

Bone Preparation

Pre-Cutting

Note: Pre-cutting holes in the tibia and talus will be essential to ensure quality bone resection during the definitive bone preparation.

Attach Pre-Cutting Guide for gross bone removal.

- A Pre-Cutting Guide will be used to create a series of perforation holes on the tibia and talus.
- Remove the Cutting Guide and replace with the same size Pre-Cutting Guide.
- Lock the Pre-Cutting Guide with the Cutting Guide Pin to prevent rotation (Fig. 41).

- Ensure that the lock/unlock symbols are facing laterally.
- Tighten the A/P Stops fully to firmly secure the Pre-Cutting Guide.

Note: The rotation of the Pre-Cutting Guide can be adjusted independently for the tibia and talus to ensure that the most appropriate hole placements are achieved on each. Depending on positioning and anatomic variances, some holes might not fully align with the bone. If the most anterior or posterior holes for the talus do not engage bone, fine adjustments to the bone resection may be necessary to accommodate the implant.

Instruments



Pre-Cutting Guide
00-4501-046-01_06



Cutting Guide Pin
00-4501-075-00



Pre-Cut Guide Drill
00-4501-059-00

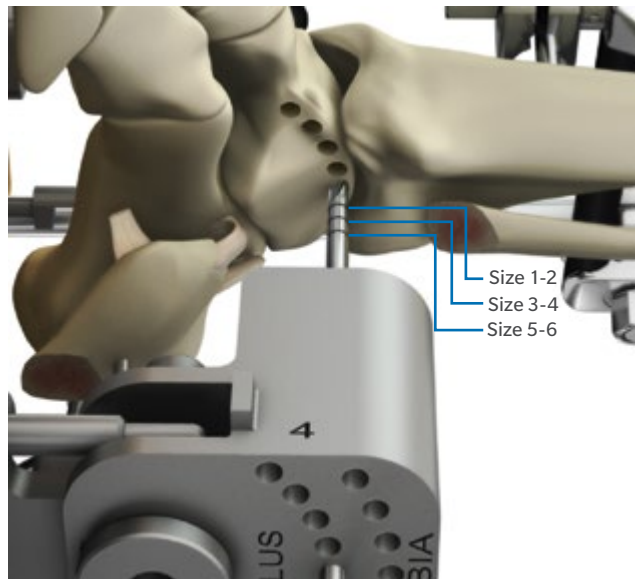

Fig. 42 Perforate bone for selected implant size.

Perform gross bone removal using Pre-Cutting Guide.

- Use the Pre-Cut Guide Drill to drill through each hole in both rows of the Pre-Cutting Guide (Fig. 42).
- Use a peck drilling technique to help prevent deflection.
- Drill until the etch line of the chosen size contacts the lateral edge of the bone. Or under fluoroscopy, guidance drill to the medial cortex of the apex of the talus and re-chuck the Pre-Cut Guide Drill to create a hard stop.
- Precut both the talus and the tibia.
- Use fluoroscopy during drilling to minimize the risk of drilling into the medial structures.

Resect Bone

Attach Cutting Guide for final bone resection.

- The Cutting Guide will be used to guide bone removal using a sweeping bur technique.
- Loosen the A/P Stops and remove the Pre-Cutting Guide.
- Attach the Cutting Guide.
- Place the Cutting Guide Pin in the unlocked proximal position.

Instruments



Pre-Cutting Guide
00-4501-046-01_06



Cutting Guide Pin
00-4501-075-00



Pre-Cut Guide Drill
00-4501-059-00

Surgical Technique



Fig. 43

Assemble Bur to compatible drill.

- Set the safety switch on a medium-speed bone drill to the “SAFE” position.
- Attach the Bur to the bone drill (Fig. 43).
- Use of a compatible device listed in Fig. 44 is required.
- Slide or thread the corresponding Bur Guard over the Bur until fully engaged with bone drill (Fig. 45).
- Lock the Bur and Bur Guard in position.
- Check to ensure that the Bur is fully engaged and locked in the hand piece.

Compatible Drill Model	Corresponding Bur Guard
Brasseler PneuMicro™* Model PM	Bur Guard A
Hall+ Micro 100™+ Model 5053	
Hall+ MicroPower™+ Model 6020	
Hall+ MicroPower+ Model 6021	
MicroAire®‡ 1930 Micro Drill	Bur Guard B
Stryker®± 5100-15-250 MD Series Medium Straight Attachment**	Bur Guard C
Stryker®± 5100-15-270 MD Series Long Straight Attachment**	

* PneuMicro is a trademark of Brasseler U.S.A., Inc.
 + Hall; Micro 100; and MicroPower are trademarks of Linvatec Corporation.
 ‡ MicroAire is a trademark of MicroAire Surgical Instruments LLC.
 ± Stryker is a trademark of Stryker Corporation.
 ** Drill speed should not exceed 20,000 RPMs.

Fig. 44

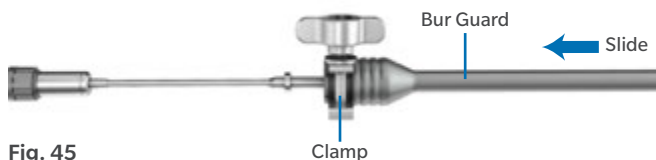

Fig. 45

Instruments



Bur
00-4501-076-00



Bur Guard A
00-4501-077-00

-OR-

Bur Guard B
00-4501-081-00

-OR-

Bur Guard C
00-4501-083-00



Fig. 46

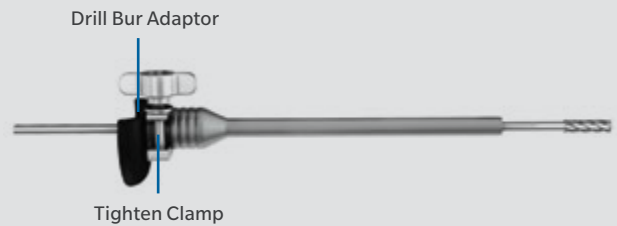

Fig. 47

Alternate Bur Handpiece Assembly

Note: It is recommended that the standard Bur and handpiece be used for this operation. The alternative presented here is meant to be utilized in unusual circumstances, such as intraoperative failure of the recommended handpiece.

Assemble Alternate Bur to a standard bone drill.

- Slide Bur Guard A over the Alternate Bur (Fig. 46).
- Feed the chuck end of the Alternate Bur through the Drill Bur Adaptor until the Bur Guard is fully seated (Fig. 47).
- Lock Bur Guard A into place.

- Assemble the Alternate Bur to a drill using a standard Jacob's Chuck attachment. Use of a reamer attachment is not recommended.
- Ensure that the drill chuck does not contact the Drill Bur Adaptor.
- Check to ensure that the Bur is fully engaged and locked to the drill.

Note: The Bur and Alternate Bur are different sizes and cannot be used interchangeably.

Note: When using the Alternate Bur, hold the flared end of the Bur Guard with one hand while holding the drill with the other to prevent the possibility of the Bur Guard spinning during use.

Instruments



Alternate Bur
00-4501-076-01



Bur Guard A
00-4501-077-00



Drill Bur Adaptor
00-4501-078-01

Surgical Technique

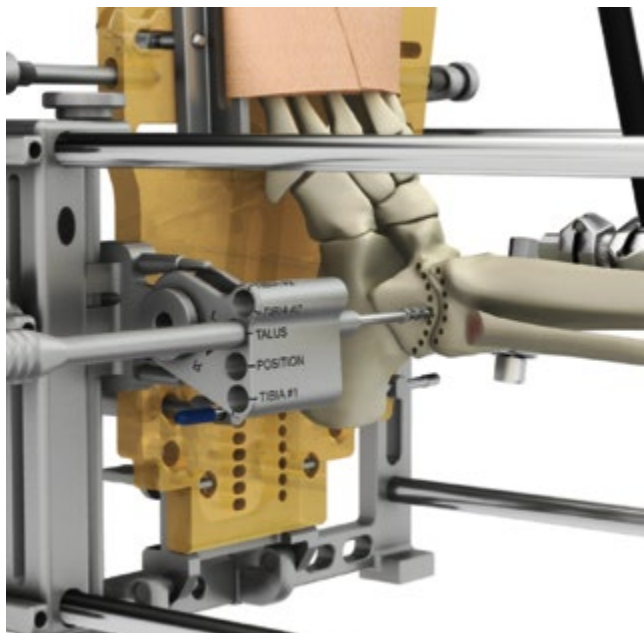

Fig. 48

Initial Talar Surface Preparation

Establish medial depth of resection using the Bur Guard Stop.

- Insert the burr assembly through the “Talus” hole in the Cutting Guide until the tip of the Burr contacts the lateral side of the talus at the top of the talar dome (Fig. 48).
- Snap the Bur Guard Stop over the Bur Guard so that the extension is facing the Cutting Guide and the arrow etching is pointing toward the ankle joint.

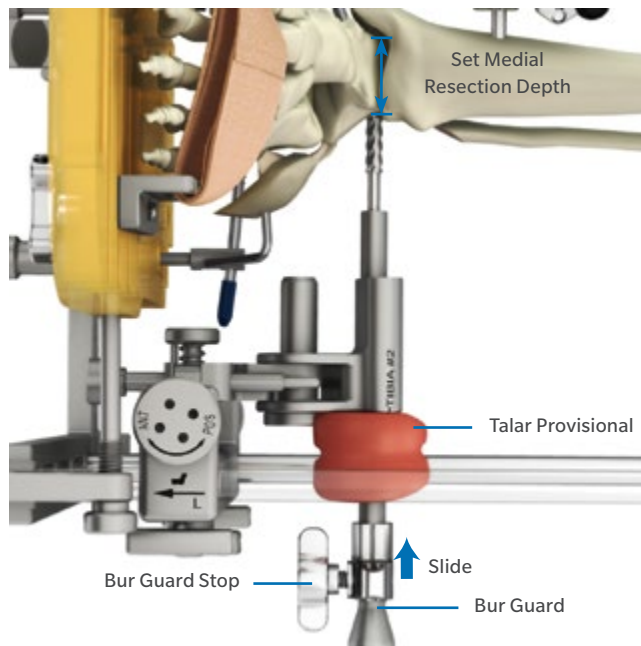

Fig. 49

- Set the position of the Bur Guard Stop (Fig. 49).
 1. Rest the Talar Provisional for the selected implant size above the Bur Guard so the center, medial edge contacts the outside of the Cutting Guide to ensure total implant width is accommodated in the cut.
 2. Slide the Bur Guard Stop medially until the extension contacts the lateral edge of the Provisional.
 3. Tighten the knob on the Bur Guard Stop.
 4. Remove the Talar Provisional.

Instruments



Bur Guard Stop
00-4501-057-00



Talar Provisional
00-4501-01X
_02X-00

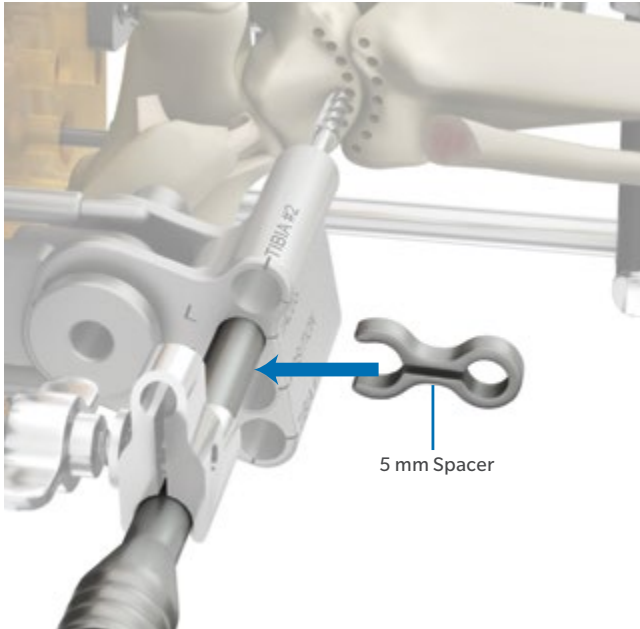

Fig. 50

Attach the 5 mm Spacer to protect the medial malleolus by initially reducing the width of talar resection.

- Snap the 5 mm Spacer onto the Bur Guard between the Bur Guard Stop and the Cutting Guide (Fig. 50).
- The remainder of the talus will be cut under increased visibility after the tibial cut is completed.

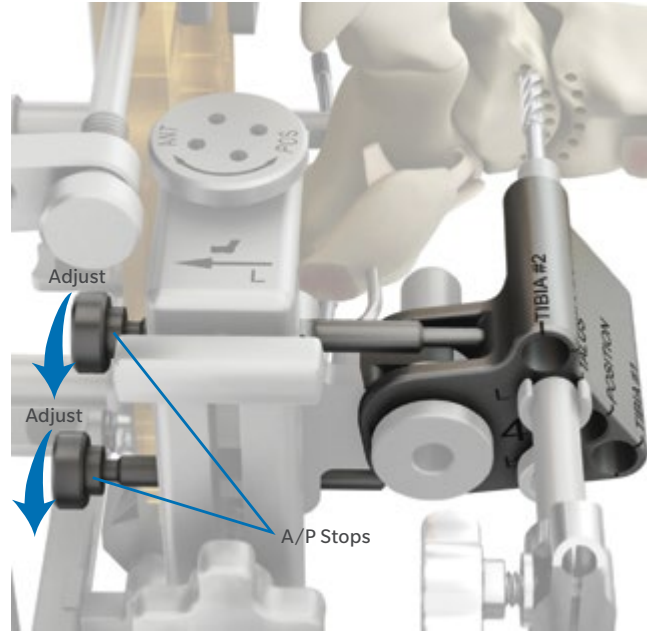

Fig. 51

Visualize the A/P talar bone removal prior to resection.

- Fully back out the A/P Stops.
- Without cutting, sweep the Bur to determine the end points of the cut and confirm the proper sweep of the cut.
- Ensure that the fibula is distal enough to not interfere with the sweep.

Control the A/P extent of resection by setting the A/P Stops.

- Position each A/P Stop by turning the knob until the tip of the Stop contacts the Cutting Guide (Fig. 51).
- The most anterior and posterior talus holes previously drilled using the Pre-Cutting Guide indicates the required minimum A/P extent of the talus cut.
- The center of the Bur head should align to the center of the most anterior and posterior Pre-Cutting Guide talus holes.

Instruments



5 mm Spacer
00-4501-057-05



A/P Stops (2)
00-4501-073-00

Surgical Technique

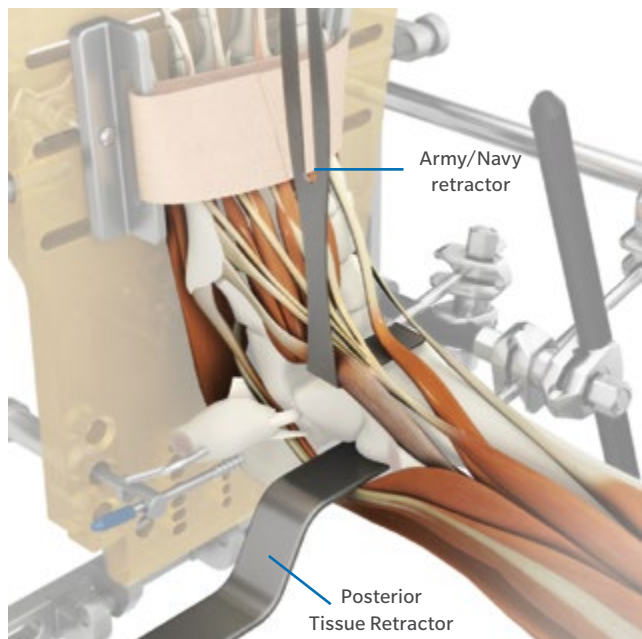

Fig. 52

Insert Retractors to protect vital structures while cutting.

- Insert an Army/Navy Retractor anteriorly to protect the anterior soft tissue structures (Fig. 52).
- Insert Posterior Tissue Retractor posterior to the ankle joint to protect the posterior soft tissue structures.

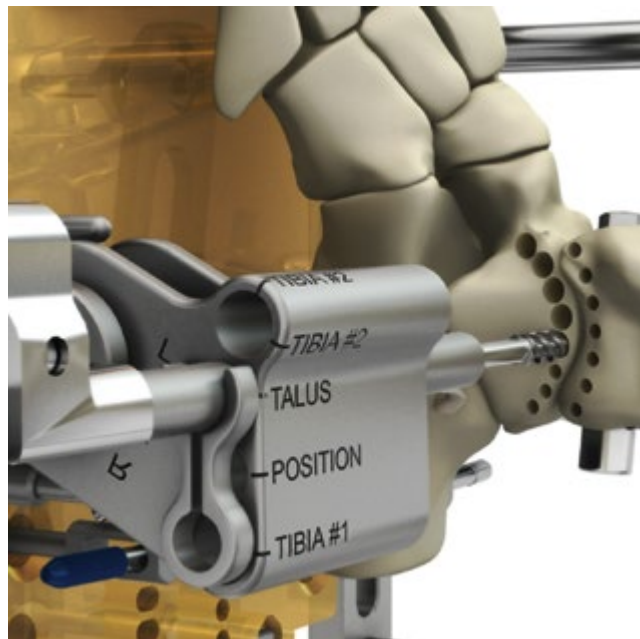

Fig. 53

Remove talar bone: Nesting holes step.

- Use end-cutting by advancing the Bur into the bone a few millimeters medially.
- Create a pattern of nested holes in the talus (Fig. 53).
- ⊞ **Note:** Irrigation should be employed during cutting to reduce heat generation.
- ⊞ **Note:** If using the Alternate Bur or Bur Guard B, hold Bur Guard during buring operation to prevent Bur Guard from spinning.

Instruments



Posterior Tissue Retractor
00-4501-082-00

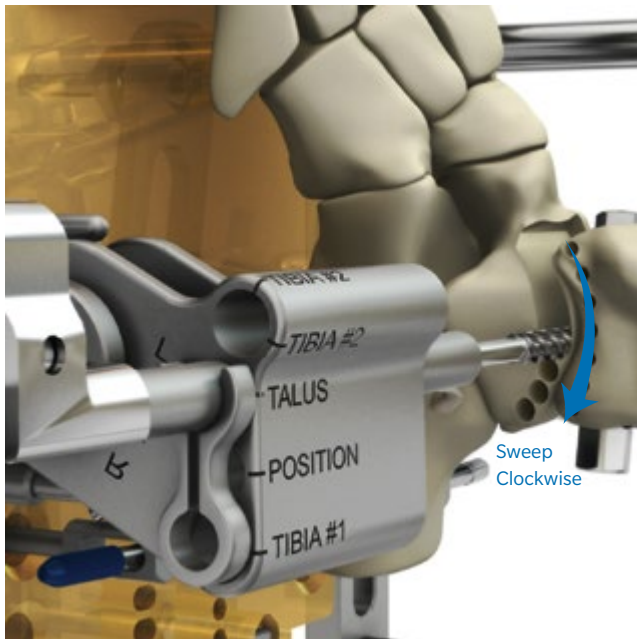

Fig. 54 Remove bone using the provided Bur.

Remove talar bone: Sweeping motion step.

- Sweep the Bur over the perforated area (Fig. 54).
- For a smoother surface, cut only in a clockwise direction on the talus.
- To maximize control of the cut, hold the Cutting Guide with one hand and the bone drill with the other, and rotate them together.
- If cutting performance degrades, consider using a new Bur.

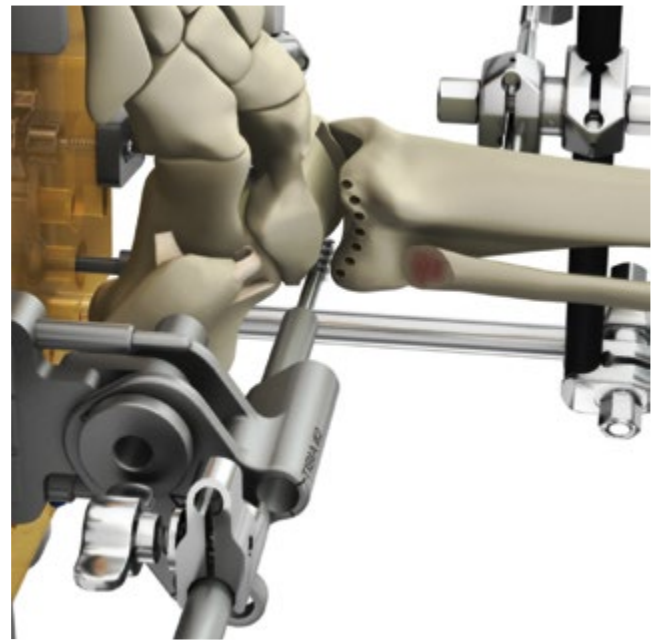

Fig. 55

Complete initial talar resection by repeating bone removal steps until at depth of 5 mm Spacer.

- Continue to cut an additional few millimeters of the talus using the same peck and sweep method.
- Repeat until the 5 mm Spacer contacts the Cutting Guide (Fig. 55).
- If desired, use fluoroscopy at any point to confirm the position of the cutting tool.

Note: The medial side of the talus will NOT yet be cut.

Surgical Technique

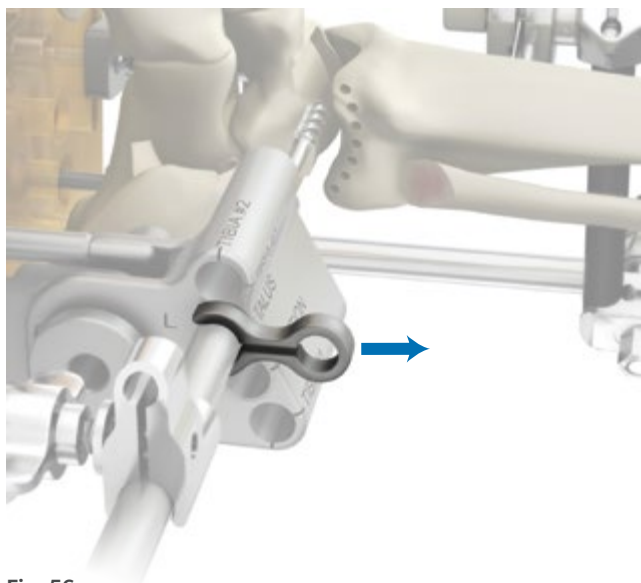

Fig. 56

Tibial Surface Preparation

Visualize tibial bone removal.

- Remove the 5 mm Spacer to ensure full implant depth is resected from the tibia (Fig. 56).
- Do not adjust the Bur Guard Stop.

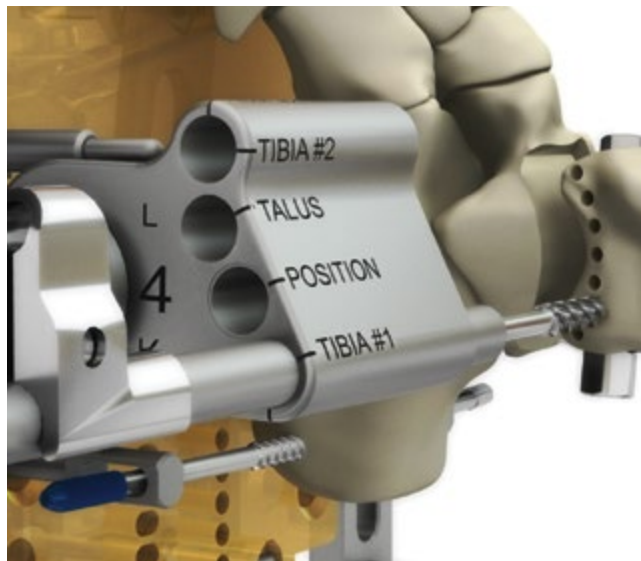

Fig. 57

- Insert the bur assembly through the “TIBIA #1” hole in the Cutting Guide (Fig. 57).
- Back out the A/P Stops.
- Without cutting, sweep the Bur to determine the end points of the cut.
- The tibia will be fully cut, from anterior to posterior.

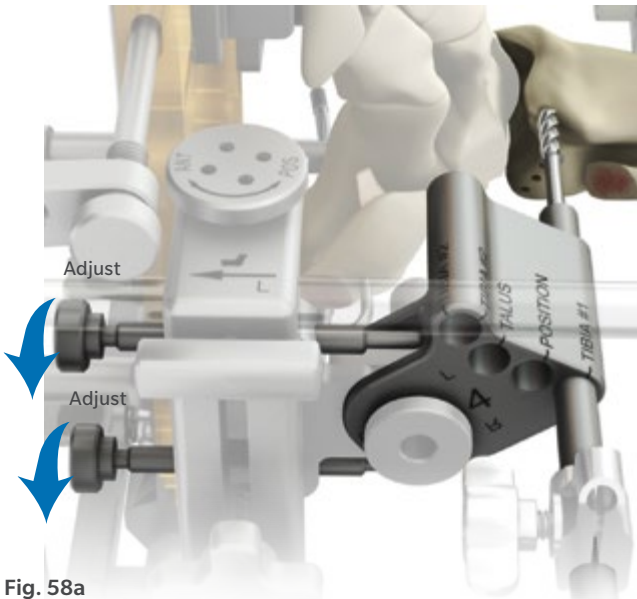

Fig. 58a

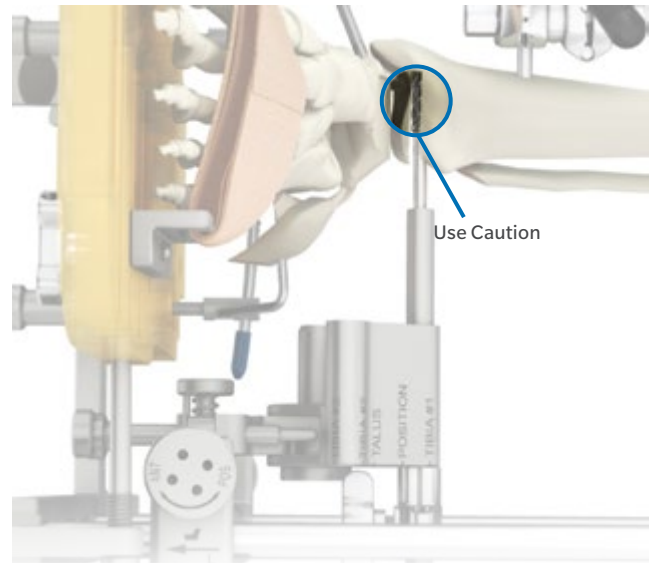

Fig. 59

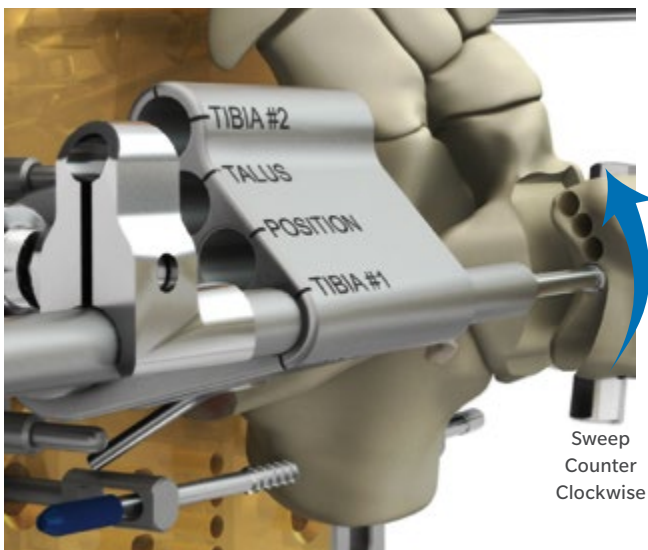

Fig. 58b

Control the A/P extent of resection by setting the A/P Stops.

- Position the appropriate A/P Stop by turning the knob until the tip of the stop contacts the Cutting Guide (Fig. 58a & 58b).

Remove tibial bone.

- Use the same technique used for the talus, but sweep the Bur in a counterclockwise direction when cutting.
- Repeat the peck and sweep sequence until the Bur Guard Stop contacts the Cutting Guide.
- As the Bur approaches the medial side of the tibia, use fluoroscopy to avoid compromising the bony support for the medial malleolus (Fig. 59).
- Ensure posterior and anterior retractors are also in place to protect tissues.

Instruments



A/P Stops (2)
00-4501-073-00

Surgical Technique



Fig. 60

Remove remaining bone and debris from the resected area.

- Remove the remaining wafer of tibial bone with a small rongeur.
- Wash any fragments from the joint, collecting any morselized bone for use as a graft later in the procedure.

Complete remaining tibial resection with the TIBIA #2 hole.

- Insert the bur assembly into the “TIBIA #2” of the Cutting Guide (Fig. 60).
- Do not adjust the Bur Guard Stop.
- Readjust the A/P Stops as necessary to remove the remaining bone on the medial wall of the resected tibia.
- Use the peck and sweep technique to complete the center cut until the Bur Guard Stop contacts the Cutting Guide.

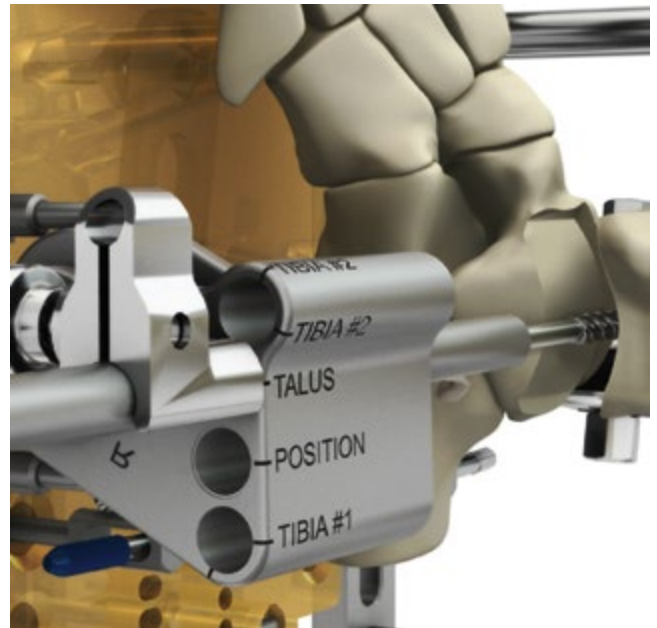

Fig. 61

Final Talar Surface Preparation

Control the A/P extent of resection by setting the A/P Stops.

- Reinsert the bur assembly into the “TALUS” hole of the Cutting Guide (Fig. 61).
- Adjust the A/P Stops to the extent of the initial talar surface preparation.
- Insert an additional Malleable Retractor In the medial clear space to protect the medial malleolus.
- Ensure posterior and anterior retractors are also in place to protect tissues.

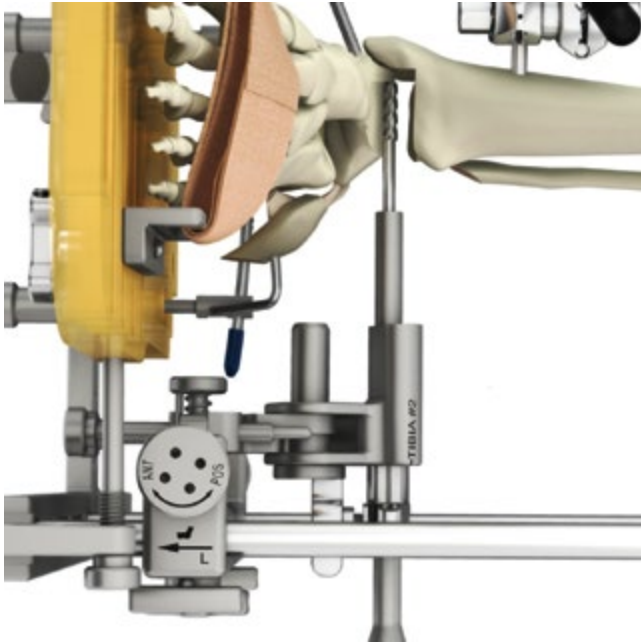

Fig. 62

Complete talar resection to full depth of Bur Guard Stop.

- Continue to remove the remaining medial portion of the talus in a clockwise direction until the Bur Guard Stop contacts the Cutting Guide (Fig. 62).
- After each cutting pass, remove any bone fragments that might block visibility.
- The medial incision and tibial cut provide visibility to help avoid cutting into the medial malleolus and posterior medial soft tissues.
- If desired, use fluoroscopy.

☰ **Note:** Due to the proximity of the posterior medial neurovascular bundle, ensure that the Posterior Tissue Retractor is positioned to shield the structures from the Bur.

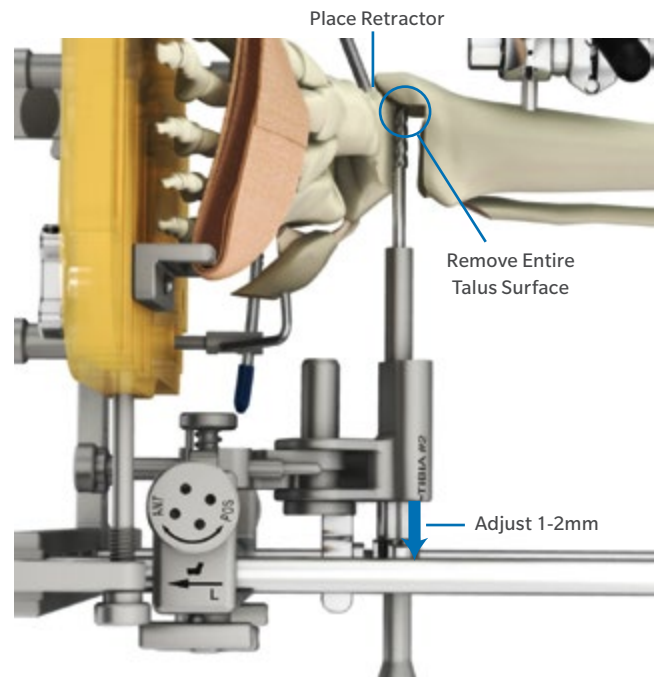

Fig. 63

Perform controlled resection of any talus bone remaining in the resected area.

- Progressively adjust and lock the Bur Guard Stop in 1-2 mm increments laterally to allow for full talar surface preparation medially (Fig. 63).
- Be sure to fully prepare the entire surface with no remaining prominences, including the posterior medial corner, to enable full seating of the implant.
- Palpate the bone resection to verify that bony prominences have been adequately removed.

▶ **Caution:** Ensure that Bur does not contact or compromise medial malleolus.

Surgical Technique

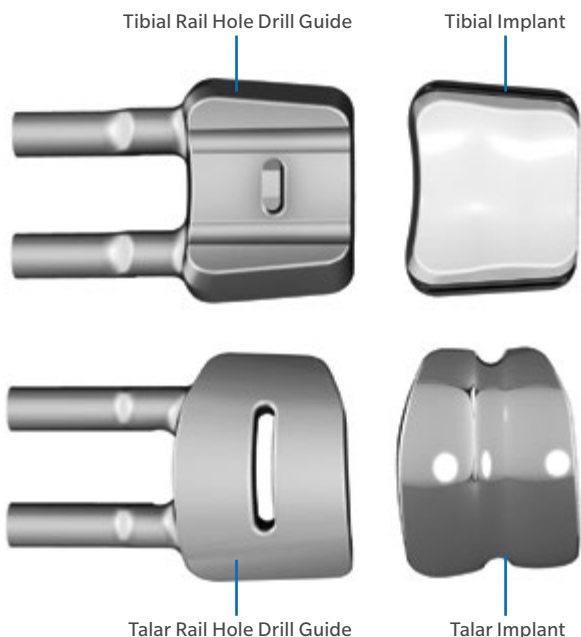

Fig. 64

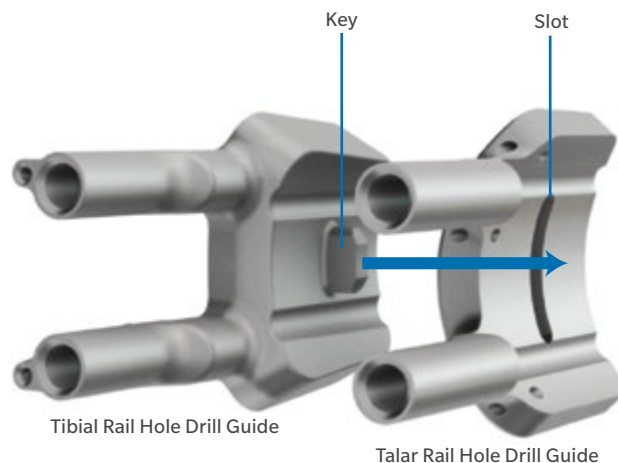

Fig. 65

Rail Hole Preparation

Insert the Rail Hole Drill Guides

Assemble Rail Hole Drill Guides.

- Select appropriate size and side (left or right) Talar and Tibial Rail Hole Drill Guides.
- The Drill Guides replicate the final implant dimensions to confirm proper bone preparation and implant positioning (Fig. 64).

- Link drill guides together using key/slot features (Fig. 65).

Note: Proper placement of the Drill Guides is essential in ensuring proper implant positioning. Implant M/L depth, A/P position and axial alignment will be established by the rail holes.

Instruments



Talar Rail Hole Drill Guide
00-4501-01X_02X-06



Tibial Rail Hole Drill Guide
00-4501-03X-06

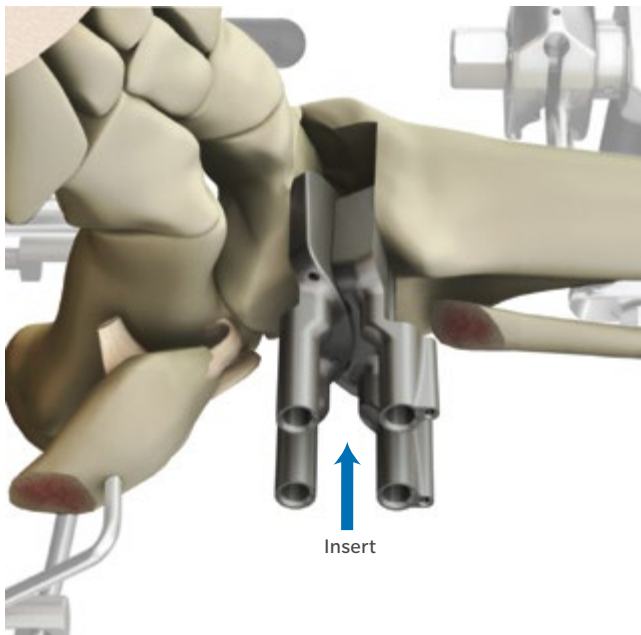

Fig. 66

Insert and position the Rail Hole Drill Guides into the resected area.

- Place the Rail Hole Drill Guides into the ankle resection between the talus and tibia with drill holes pointing laterally (Fig. 66).
- Ensure that the drill guides are centered on the resected talus.
 - If the medial tibial preparation is interfering, remove the guides and resect additional tibial bone using the cutting guide.
 - If the tibial chaput tubercle is interfering, remove the guides and remove enough of the prominence to allow full insertion.

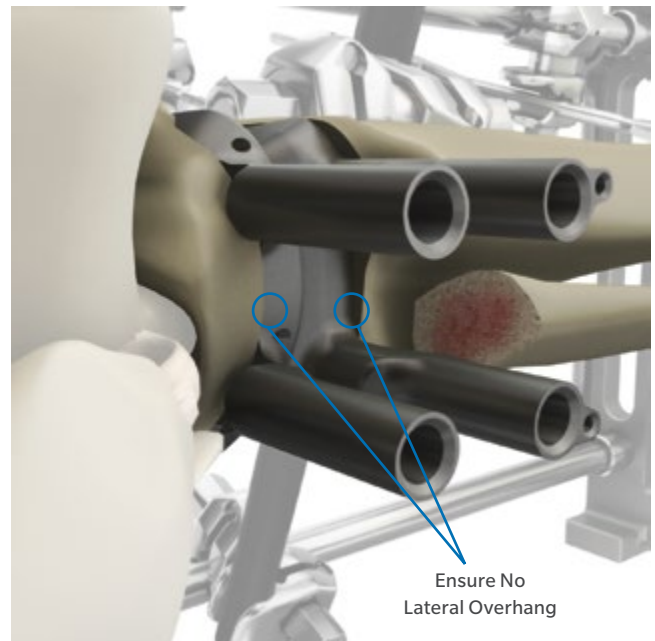

Fig. 67

- Adjust the position of the Rail Hole Drill Guides manually to ensure that they are in the desired M/L and A/P locations.
 - Ensure that the guides are placed medial enough such that there is no lateral overhang (Fig. 67).
 - The two guides can be rotated relative to each other to ensure that the most appropriate A/P coverage of each bone is achieved.
- ▶ **Caution:** Do NOT impact on the Rail Hole Drill Guides.
- ☰ **Note:** Additional bone removal from the tibia (medial bone resection and/or chaput tubercle) may be required in order to centralize the Drill Guides.

Surgical Technique

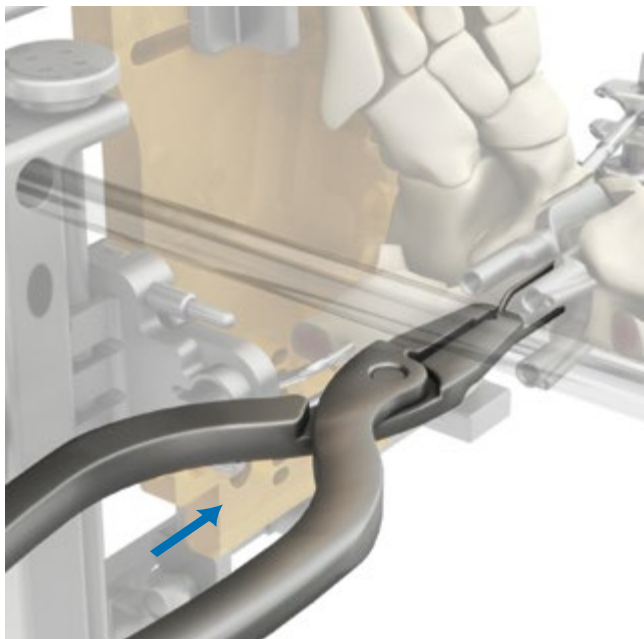

Fig. 68

Ensure tight fit by inserting Spreader Pins.

- The guides must fit tightly against the bony surfaces to drill the rail holes to ensure proper rail hole preparation.
- Use the Spreader Pin Inserter to place the smallest Spreader Pin between the two Drill Guides (Fig. 68).
- Toggle the Rail Hole Drill Guides to assess their fit.
- If the guides are even slightly loose and not flush against the cut surfaces of the bone, remove the Spreader Pin and insert a larger Spreader Pin until a rigid fit is achieved.

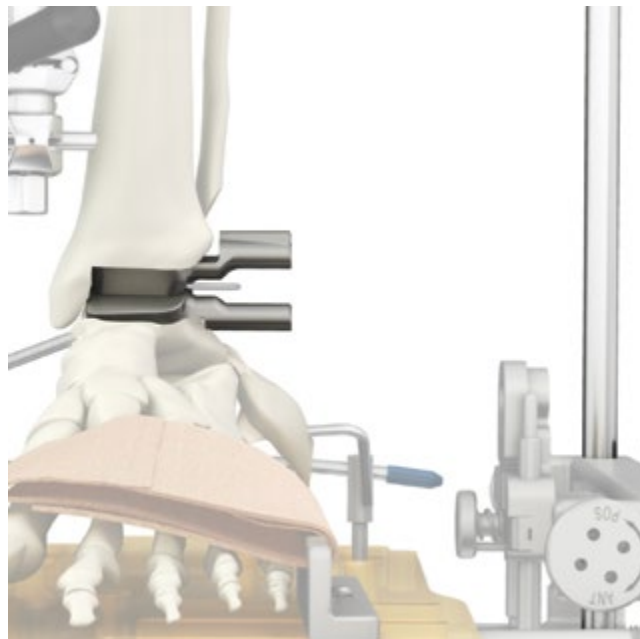

Fig. 69

Caution: Do not impact the Spreader Pins or Spreader Pin Inserter.

Note: Ensure that Spreader Pins are not inserted past the medial edge of the Rail Hole Drill Guides.

Assess position of Rail Hole Drill Guides visually.

- Confirm that the sleeves of the Rail Hole Drill Guides are perpendicular to the Frame Rods to ensure proper axial orientation to the bone resection (Fig. 69).

Instruments



Spreader Pin Inserter
00-4501-045-00



Spreader Pin
00-4501-045-01_04

Mechanical
Axis



Fig. 70

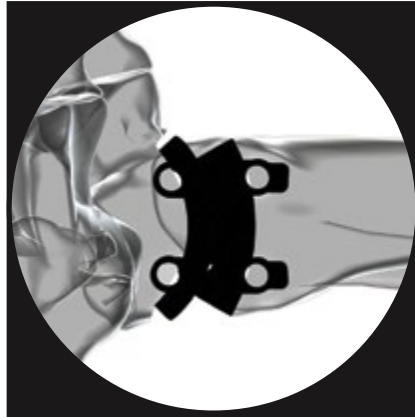

Fig. 71



Fig. 72

Assess alignment of Rail Hole Drill Guides using fluoroscopy.

- Be sure that the Rail Hole Drill Guides are accurately positioned, as this will determine where the rails for the implant will be located.
- Use fluoroscopy to check both the A/P and M/L position of the Rail Hole Drill Guides.
- In the A/P view, ensure that the Rail Hole Drill Guides are inserted far enough medially to eliminate any overhang on the lateral edge of the tibia or talus that would impinge on the fibula (Fig. 70).
- Check for any skewing of the Rail Hole Drill Guides in the A/P view.
- Position the drill guides so that they are centered relative to the mechanical axis. Utilize the notch feature in the Tibial Rail Hole Drill guide to centralize the components.
- In the lateral view, ensure that both Rail Hole Drill Guides are positioned to minimize anterior or posterior component overhang (Fig. 71).

⊖ **Note:** The Spreader Pin may need to be temporarily removed if the position of the Rail Hole Drill Guides needs to be adjusted significantly.

⊖ **Note:** If the resected fibula is impinging on the Talar Rail Hole Drill Guide, have an assistant apply pressure to hold the fibula out of the way during drilling to ensure that the Rail Hole Drill can be drilled to full depth.

ⓘ **Caution:** If there is tibial A/P overhang, position the component so that the overhang occurs anteriorly. Posterior overhang may interfere with the surrounding structures.

Assess fit using fluoroscopy.

- The Rail Hole Drill Guides must be flush against the tibia and talus in order to have an accurately placed implant.
- Use A/P and M/L fluoroscopic views to evaluate the fit of the Rail Hole Drill Guides to the bone cuts (Fig. 72).
- No gap should be noticeable between the Rail Hole Drill Guides and the bone except under the rail hole drilling reliefs.
- If there is a gap, identify the cause, then remove the Rail Hole Drill Guides and correct the gap, which may require additional bone removal with the bur or a small rasp.
- After correcting a gap, replace the Rail Hole Drill Guides and recheck the fit to the prepared bone surfaces.

Surgical Technique

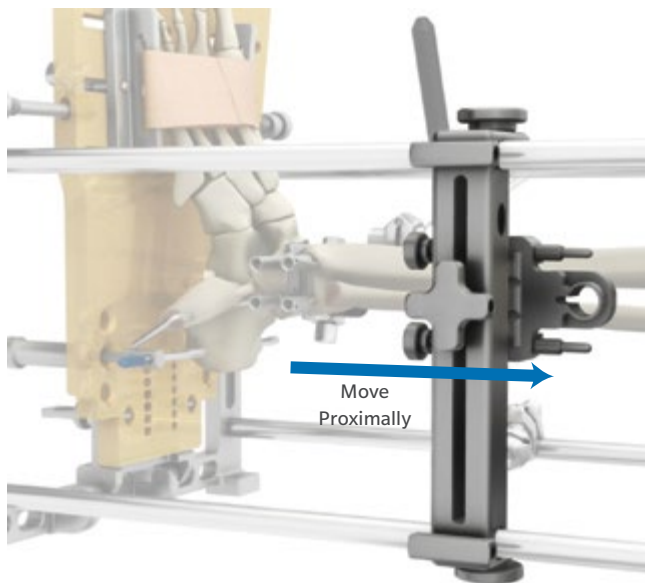

Fig. 73

Move the Lateral Cut Guide Assembly proximally to reduce interference during rail hole drilling (Fig. 73).

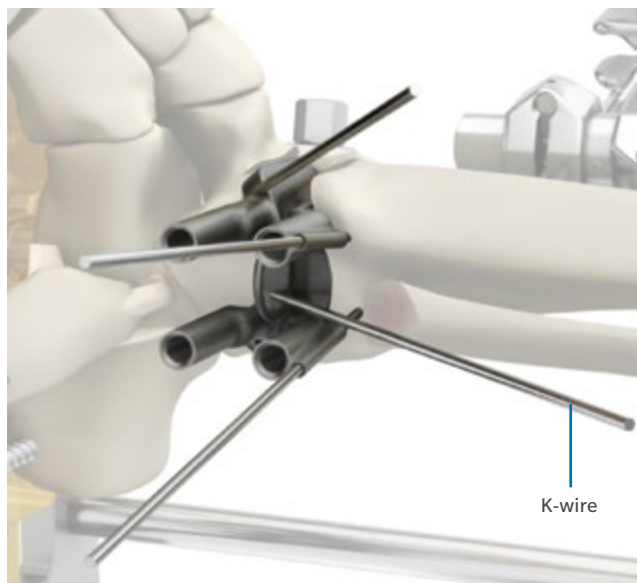

Fig. 74

Affix the Rail Hole Drill Guides to the bone using K-wires. Secure the Rail Hole Drill Guides with four 1.6 mm K-wires (Fig. 74).

- ⓘ **Note:** Visualize the trajectory path of the K-wire holes in the Talar Rail Hole Drill guides prior to inserting the K-wires.
- ⚠ **Caution:** Be careful not to alter the position of the Rail Hole Drill Guides when inserting the K-wires.
- ⚠ **Caution:** Protect skin and soft tissues by ensuring that K-wires do not advance past the medial cortex.

Instruments



1.6 mm K-wire (4)
00-4501-040-01

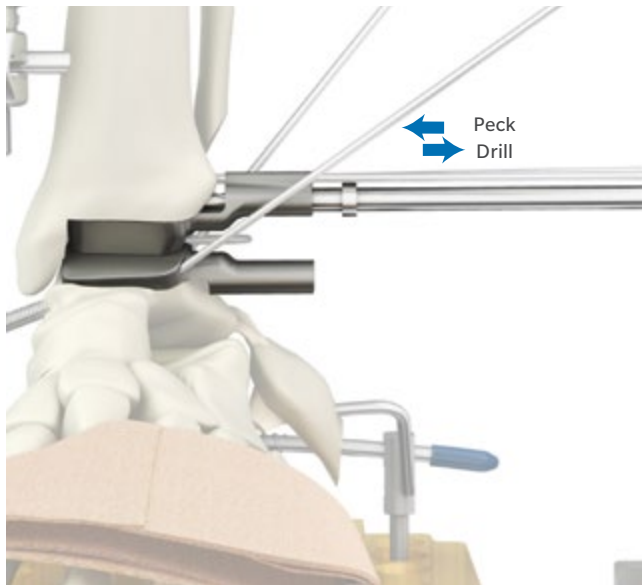

Fig. 75 Drill rail holes for the implants.

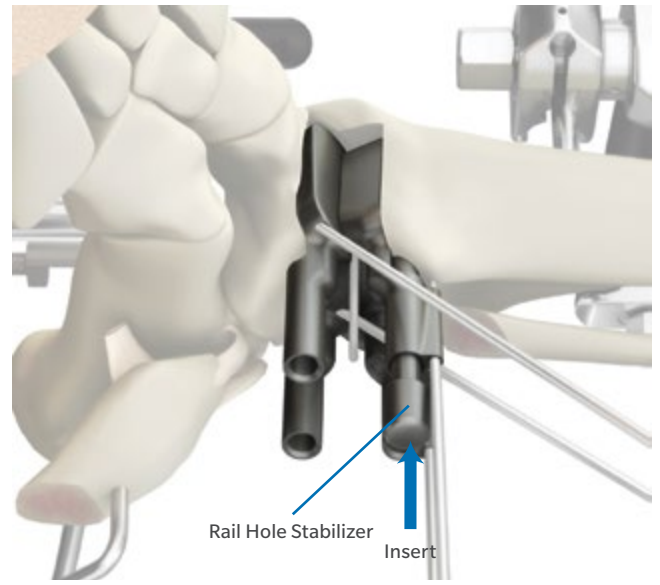

Fig. 76

Drill the Rail Holes

- Insert the Rail Hole 5 mm Drill through one sleeve in the Tibial Rail Hole Drill Guide.
- Use a peck drilling technique to advance the drill until the stop contacts the sleeve (Fig. 75).
- Remove the drill and insert the Rail Hole Stabilizer into the prepared hole (Fig. 76).
- Repeat the drilling procedure through the second sleeve in the Tibial Rail Hole Drill Guide.
- Insert a second Rail Hole Stabilizer into prepared hole.
- Use the same drilling procedure to create the talar rail holes.
- Be sure to use the Rail Hole Stabilizer in the first talar hole before drilling the final hole.
- Ensure Rail Hole Stabilizers are placed into all four holes after drilling is completed.

Instruments



Rail Hole Drill
00-4501-058-00



Rail Hole Stabilizer (4)
00-4501-058-01

Surgical Technique



Fig. 77

Confirm rail hole alignment with fluoroscopy.

- Confirm that Rail Hole Drill Guides have maintained intimate contact with bone (Fig. 77).
- Confirm through lateral fluoroscopy that no lift-off is detected.
- If Rail Hole Stabilizers cause the Rail Hole Drill Guides to sit proud to the bone, redrill the rail holes to correct the issue.

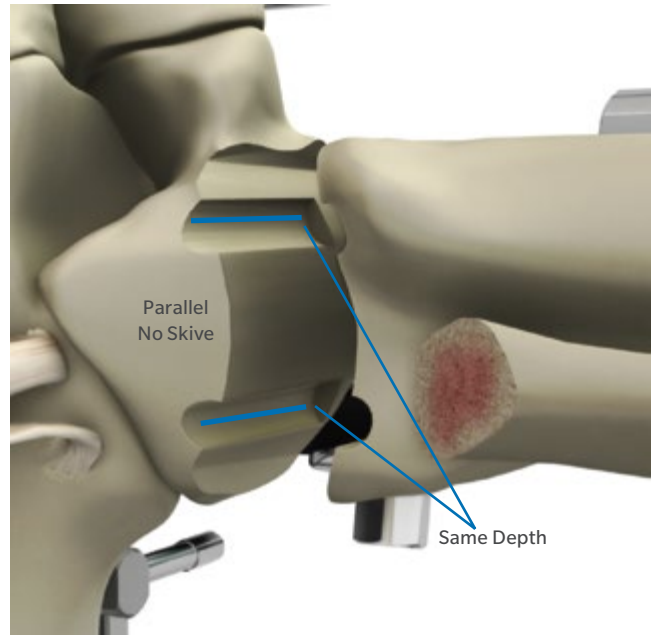

Fig. 78

Inspect the drilled rail holes for consistent depth and alignment.

- Remove the K-wires and Spreader Pin.
 - Remove the Rail Hole Drill Guides and Rail Hole Stabilizers.
 - Inspect the rail holes to ensure that the drill did not skive, that the holes are consistent in size and that the rail holes are parallel to each other (Fig. 78).
 - If the holes are not consistent across the joint, correct the issue by reinserting the components and repeating the drilling procedure.
 - If necessary, clean the edges of the rail holes with a curette.
- ▶ **Caution:** If the rail holes are not prepared correctly, the implants will not seat correctly.
- ☰ **Note:** By design, the rail holes will not be to the medial edge of the resected area of the tibia and talus.

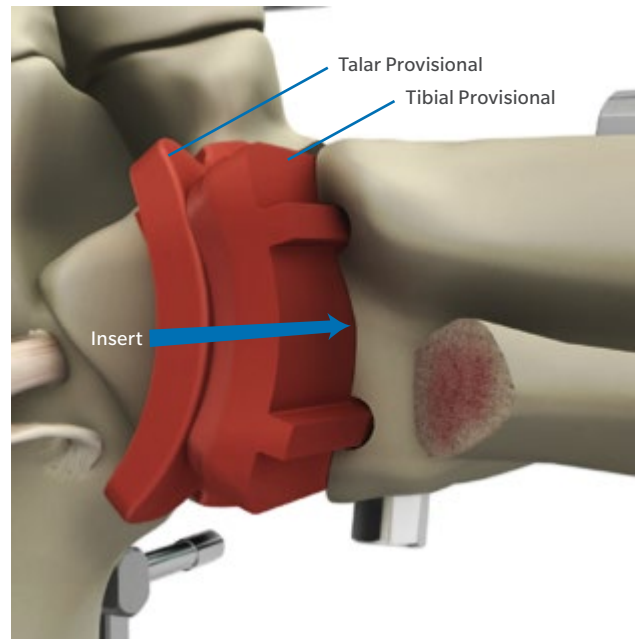

Fig. 79

Trial Reduction

Insert Provisionals to assess bone preparation and joint tension.

- Manually insert the appropriate size and side (left or right) Talar and Tibial Provisionals into the prepared joint space (Fig. 79).
- Use a nominal thickness (+0) Tibial Provisional.
- Confirm size etching is showing on lateral side of the Provisionals.
- Ensure that there is no lateral overhang of the Provisionals.
- Remove K-wire from the distal fibular segment and reduce the fibula to ensure there is no bony impingement.

- Ensure Provisionals sit flush on the prepared curved bone surfaces.
- Ensure Provisional rails are balanced in anterior and posterior rail holes.
- Confirm under fluoroscopy.
 - If the rail holes are not properly prepared, reinsert the Rail Hole Drill Guides and redrill the holes.
 - If re-drilling the holes using the Rail Hole Drill Guides still does not allow the Provisional to properly seat, consider carefully over-drilling one of the affected holes manually with the Rail Hole 5 mm Drill until the Provisional can properly seat.

Technique Tip: Mark the lateral edge of the Provisional on the bone to aid in proper M/L positioning during final implant insertion.

Instruments



Talar Provisional
00-4501-01X
_02X-00



Tibial Provisional
00-4501-03X-0Y

Surgical Technique

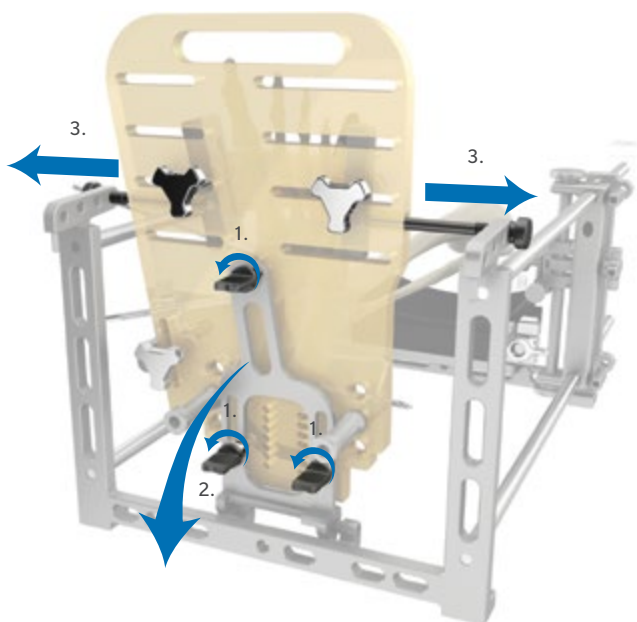

Fig. 80

Assess range of motion and joint tensioning.

- With the Provisionals in place, remove the metal Foot Plate Support.
 1. Remove the three 1/4 Turn Fasteners (Fig. 80).
 2. Use one hand to support the foot posteriorly while rotating the Foot Plate Support distally, so it rests on the table.
 3. Release the Foot Plate by removing the two Angle Locking Pins.
- Perform a trial range of motion (Fig. 81a & 81b).
- Check for bony impingement through the full range of motion.
- Assess deltoid engagement to determine the correct Tibial Implant thickness.
- Apply valgus stress and assess gapping through the medial incision.
- Manually distract the joint to assess laxity.
- If gapping and/or laxity are present, replace the Tibial Provisional with a thicker component (+2 or +4).

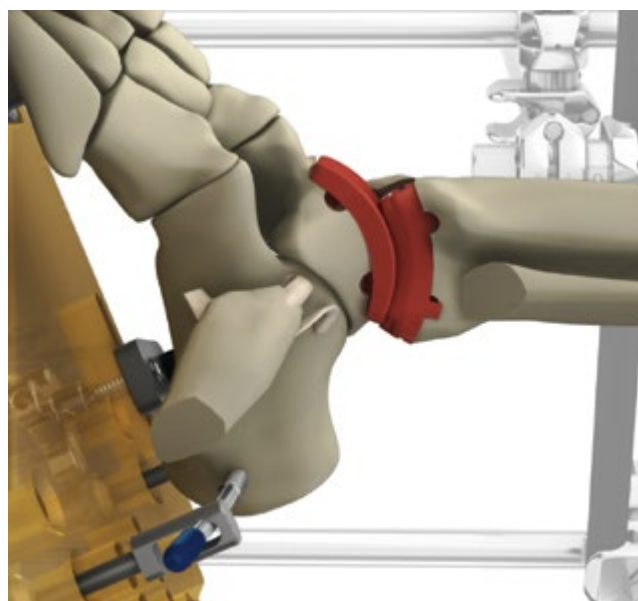

Fig. 81a

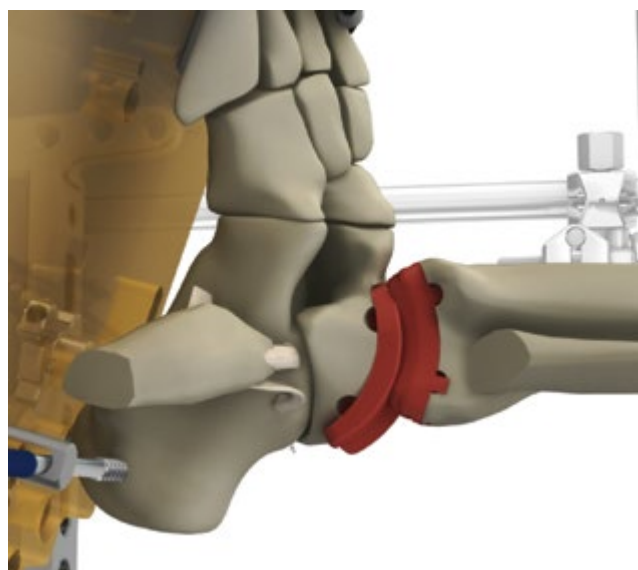

Fig. 81b Perform trial reduction and range of motion.

- Repeat the evaluation until minimal gapping and laxity are noted medially.
 - Without overstuffing the joint, minimize medial gapping while maintaining lateral congruency.
- Note:** At least 5° of dorsiflexion should be achieved. If not, consider performing a tendoachilles lengthening or a gastrocnemius recession before closing.

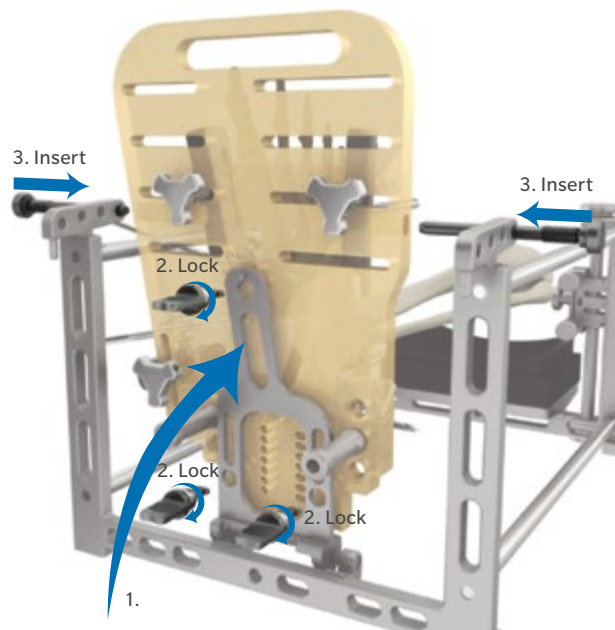

Fig. 82

Reconnect Foot Plate to prepare for final implant insertion.

- After completing the range of motion, reconnect the Foot Plate to the Alignment Stand Assembly (Fig. 82).
 1. Use one hand to support the ankle posteriorly while rotating the metal Foot Plate Support into position.
 2. Place the Foot Plate on the small ledge of the Foot Plate Support and reinsert the three 1/4 Turn Fasteners on the back of the Foot Plate.
 3. Reinsert the two Angle Locking Pins.

Note: If +4 tibial component was selected, it may be necessary to distract the resection area to accommodate the thicker poly component. To accomplish this, loosen the rod ends of the three Pin-to-Rod Clamps secured to the Alignment Rods and slide the Alignment Stand distally until the Foot Plate can be secured. Once complete, retighten the Pin-to-Rod Clamps.

Remove and clean the Talar and Tibial Provisionals.

Surgical Technique



Fig. 83

Implant Insertion

Insert Implants

Clean the joint space to prepare for implant insertion.

- To prepare for final placement of implant, the space will need to be clear of debris to have sufficient implant to bone contact.
- Use a pulsating lavage irrigation system to thoroughly clean and dry the ankle cavity.

⊞ **Note:** Ensure all Pin-to-Rod Clamps are fully tightened.

⊞ **Note:** If necessary, the implants can be inserted manually and seated using the Impactor Assembly (Fig. 83).

Instruments



Talar Inserter/
Extractor
00-4501-010-00



Impactor Handle
(optional)
00-4501-060-02



Impactor Head
(optional)
00-4501-060-01

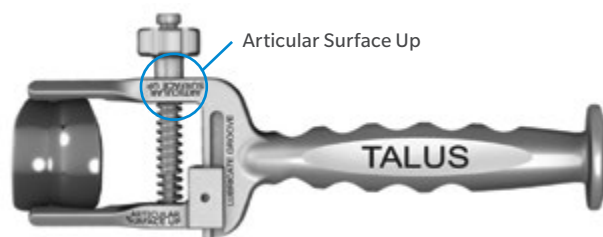

Fig. 84a

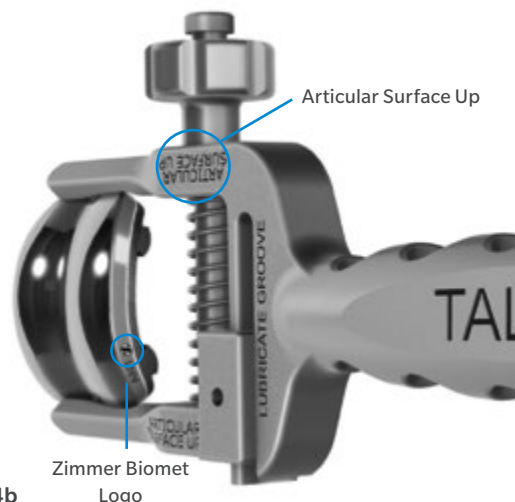

Fig. 84b

Talar Insertion

Prepare the Talar Implant for insertion.

- Select the appropriate size/side Talar Implant.
 - Confirm that the color code on the implant packaging matches the color of the Provisionals used during trialing.
- Place the Talar implant into the Talar Inserter/Extractor and tighten the nut.
- The articular surface of the implant should be oriented in the same direction as the “Articular Surface Up” instructional etch side of the inserter (Fig. 84a & 84b).

⊞ **Note:** Confirm that the Zimmer Biomet logo will be implanted on the lateral side (facing the surgeon) and that the appropriate implant side and size was chosen prior to implantation. The Talar component must be inserted first to prevent damage to Tibial articular surface.

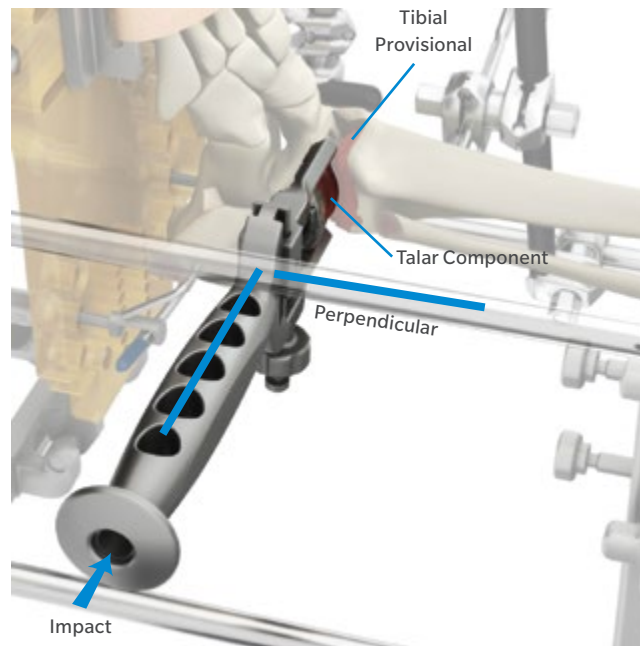

Fig. 85

Insert the Tibial Provisional.

- Clean the Tibial Provisional and place it back into the ankle cavity to use as a guide when inserting the Talar Implant.

Begin Talar Implant insertion.

- Confirm that the Zimmer Biomet logo is visible on the lateral side of the Talar Implant.
- Insert the Talar Implant into the joint so the rails are in line with the prepared holes.
- Place implant medially with hand pressure until rails engage rail holes.
- Ensure that the inserter handle is perpendicular to the alignment rods on the frame.
- Ensure that the inserter arms do not come in contact with the Tibial Provisional.

▶ **Caution:** Be careful not to angle the inserter as this could cause the rails to break out of the holes.

Impact the inserter until final talar component position is reached.

- Impact the inserter with a graduated force to drive the implant in until the rails reach the end of the drilled rail holes (Fig. 85).
- Have an assistant apply a manual force to the medial side of the joint to reduce the potential for medial malleolar fracture.
- If desired, fluoroscopy can be used to monitor insertion.
- Ensure that the implant is in the appropriate M/L location and there is no medial/lateral overhang.
- Release the Talar Inserter from the Talar Implant and remove.
- Remove the Tibial Provisional.

⊞ **Note:** Excessive force should be avoided during impaction.

⊞ **Note:** Ensure that inserters are properly lubricated prior to use. If inserters are not properly lubricated, a slight impact may need to be applied to the sliding arm after the the nut is loosened in order to disengage the implant.

Surgical Technique

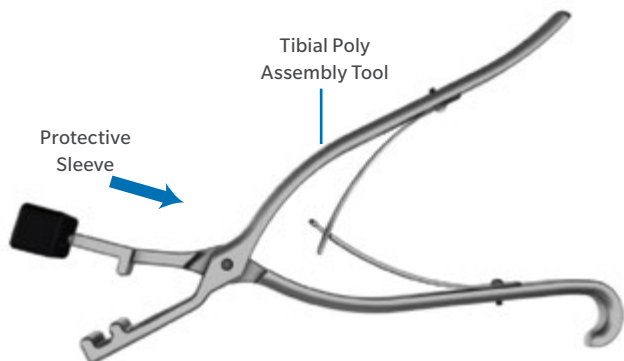

Fig. 86

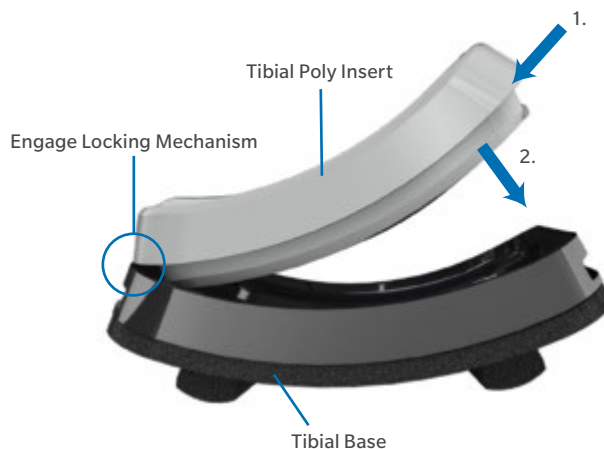

Fig. 87

Tibial Assembly

Attach the Protective Sleeve over the flat end of the Tibial Poly Assembly Tool (Fig. 86).

- The Protective Sleeve is intended to protect the poly from damage during assembly.

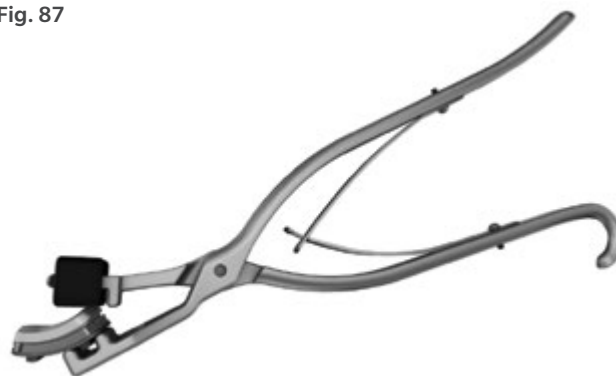

Fig. 88

Initiate assembly of Tibial components.

- Select appropriate size Tibial Base and Tibial Poly Insert.
- Slide one end of the Tibial Poly Insert into the Tibial Base (Fig. 87).
 - Confirm that the color code on the implant packaging matches the color of the Provisionals used during trialing.
- Ensure locking mechanism is engaged.
- Place Tibial assembly into Tibial Poly Assembly Tool so that one rail fits between the parallel rods and the other rail is outside of the tool (Fig. 88).
- Ensure that the unengaged end of the Poly Insert is under the Protective Sleeve of the tool.

Instruments



Poly Assembly Tool
00-4501-065-00



Protective Sleeve
00-4501-065-01

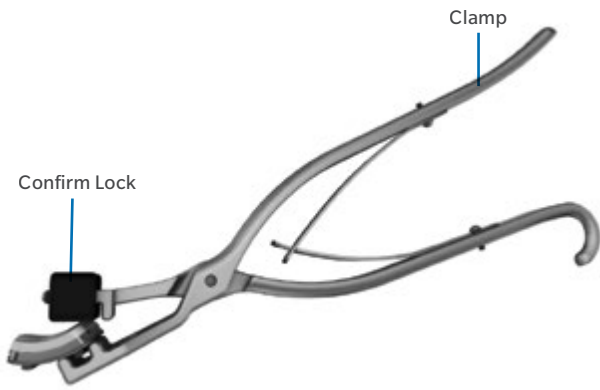

Fig. 89

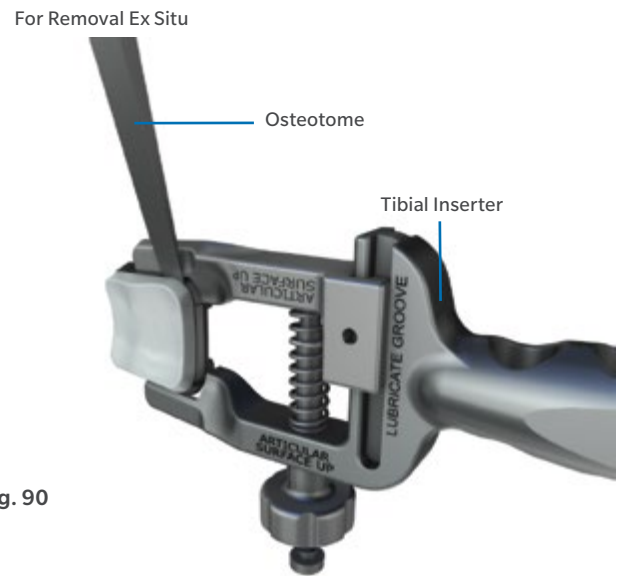

Fig. 90

Complete assembly of the Tibial Component.

- Clamp Tibial Poly Assembly Tool together, carefully ensuring that the articular surface is not damaged (Fig. 89).
- An audible and/or palpable click should be observed to verify the locking mechanism is fully engaged at time of assembly.
- Inspect poly surface to ensure that it was not damaged through assembly.
- Inspect Poly Insert and ensure that it is adequately locked to the base.

Note: If the Poly Insert needs to be removed ex situ, place the assembled Tibial Component into the Tibial Inserter to minimize risk of injury while utilizing the Osteotome (Fig. 90).

Instruments



Tibial Inserter
(Optional)
00-4501-030-00



Osteotome
(Optional)
00-2887-000-01

Surgical Technique

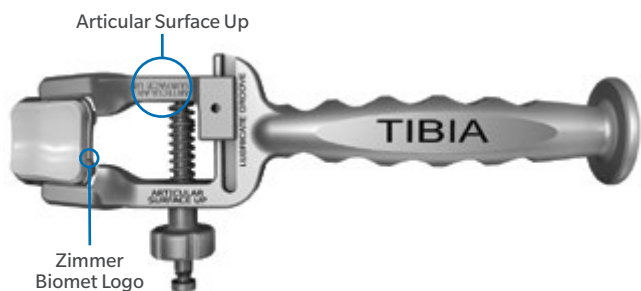

Fig. 91a

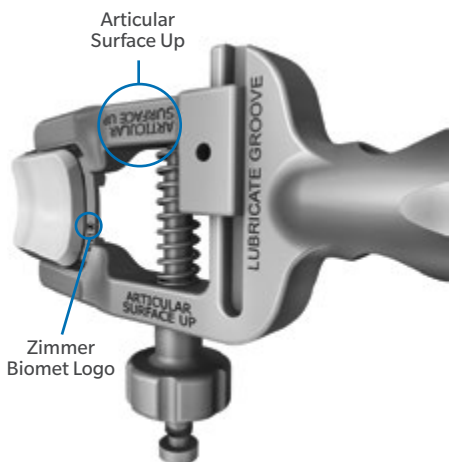

Fig. 91b

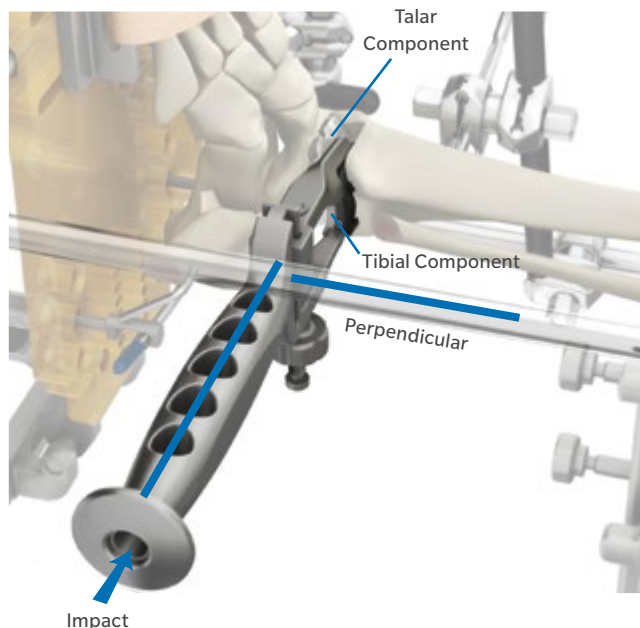

Fig. 92 Insert final implants.

Tibial Insertion

Load Tibia Components into the Tibial Inserter/Extractor Tool.

- Place the Tibial Implant into the Tibial Inserter/Extractor and tighten the nut (Fig. 91a & 91b).
- The articular surface of the implant should be oriented in the same direction as the “Articular Surface Up” instructional etch side of the inserter.

Note: Confirm that the Zimmer Biomet logo is visible on the lateral side of the Tibial Implant and that the proper size has been chosen.

Insert the Tibial Implant (Fig. 92).

- Repeat the insertion technique used on the Talar Implant.
- Ensure that the medial edge of the Tibial Insert is medial to the lateral edge of the talar component before impaction begins.

Instruments



Tibial Inserter
00-4501-030-00



Fig. 93

Confirm proper implant alignment with fluoroscopy.

- Use fluoroscopy to verify that the tibial and Talar Implants are properly aligned in the coronal plane (Fig. 93).
- If one implant needs to be moved slightly medially, use the Impactor Assembly.
- If the implants need to be moved laterally to achieve the correct alignment, use the inserters.

Assess stability of implants.

- If implants are determined to be unstable, consider utilizing the Optional Cementing Technique.
- Apply bone wax to exposed cut bone surfaces to minimize bone overgrowth.

Instruments



Cement Mixing
and Delivery System
00-4501-090-00

Temperature	Suggested Working Time
20° C / 68° F	3:45
24° C / 75° F	3:00

Fig. 94

Optional Cementing Technique

Confirm rail holes are clear of debris.

- Place Cement Delivery Needle with stylet into each of the four rail holes to ensure adequate space is available to accommodate the needle.
- If the Cement Delivery Needle does not fit under the rail, slightly open the rail hole using a K-wire.

Prepare the Cement and Delivery System.

- Remove cap from Cement Delivery Syringe and stylet from Cement Delivery Needle.
- Tighten needle onto cap.
- Mix cement in the Cement Mixing System.

Note: Osteobond® Cement is recommended for this procedure. Only low-viscosity cement should be used. Other cements (e.g., dough-type) likely will be problematic with proper delivery and implant fixation. Ensure delivery of Osteobond Cement within the working time recommendations (Fig. 94).

Surgical Technique

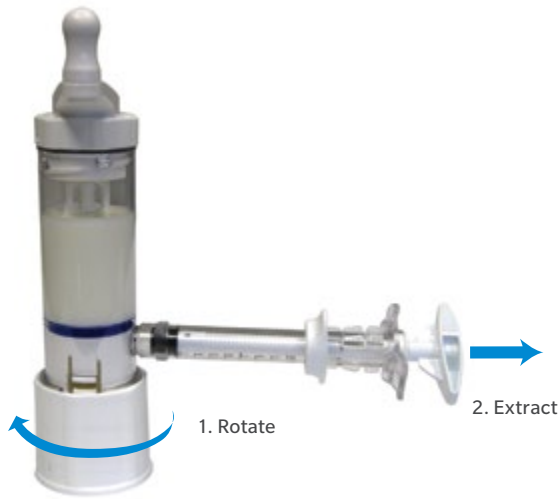

Fig. 95

Technique Tip: To aid in determining the medial depth of the rail hole that needs to be checked, use the corresponding size Talar Provisional rail feature to set a mark on the Cement Delivery Needle.

Load cement into syringe.

- As soon as cement powder and monomer are fully mixed, deliver into Cement Delivery Syringe (Fig. 95).
- Place Cement Delivery Syringe onto Cement Mixing System at extraction port. Rotate bottom of Cement Mixing System until it is below the cement extraction port.
- Draw cement into syringe, ensuring entrapped air is minimized.
- Apply cap and needle using the supplied wrench.

Eject some cement out of the needle.

- Ensure that any entrapped air has been evacuated from the syringe.

Instruments



Cement Mixing and Delivery System
00-4501-090-00

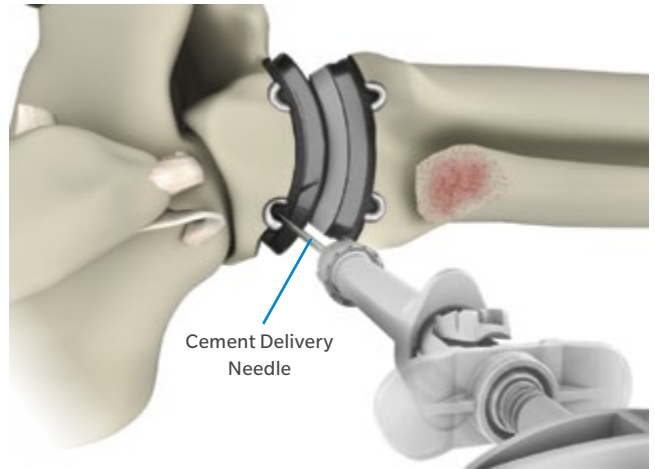

Fig. 96 Deliver cement under implant rails using the Cement Delivery Syringe and Needle.

Cement the rails.

- Deliver bone cement under each of the implant rails for the tibial and Talar Implant (Fig. 96).
- Deliver cement until the entire rail cavity is filled, utilizing a retrograde fill method.
- Ensure that the volume of cement in each hole is approximately equivalent to that noted in the table below (Fig. 97). Note that these volumes are for typical bone density and lower bone density may require additional cement to adequately fill the rail.

Recommended Cement Volumes per Rail Hole

Size	Amount of Cement per Rail Hole (ml)
1	0.8
2	0.9
3	1.0
4	1.0
5	1.1
6	1.2

Fig. 97

Remove excess cement from the joint area.

Note: It is possible for cement to flow past the medial edge of the rail hole. Fully inspect the medial aspect of the joint and ensure any cement is removed.

After cement has fully cured, assess stability of the implants.

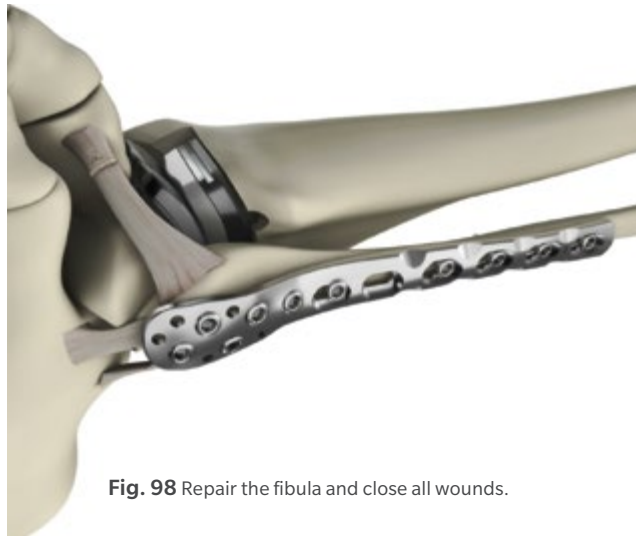

Fig. 98 Repair the fibula and close all wounds.

Repair and Closure

Fibular Repair

Prepare for closure.

- Remove the self-adhesive wrap and all pins from the anatomy.
- Remove the Alignment Stand Assembly from the table.
- Remove any debris from the ankle joint and surrounding areas.

Repair the fibula.

- Reduce the fibula and assess joint stability.
- Place the ankle in a neutral position and reduce the fibula so that the calcaneofibular ligament engages when an inversion stress is applied.
- If necessary, notch the fibula to achieve reduction when lateral overhang of the implant causes impingement.

- Use the oblique fibular cut to adjust ligament laxity as needed.
 - If any varus or valgus instability is observed, the fibula may need to be slightly shortened or lengthened.
 - Apply a fibular plate with bone screws to repair the fibula (Fig. 98).
 - Refer to Zimmer Periarticular Distal Lateral Fibular Locking Plate surgical technique (Zimmer reference 97-2347-034-00).
 - Ensure that an anatomic reduction is achieved and that proper axial orientation of the fibular fragments is maintained.
- ⓘ **Note:** Morselized bone removed during bone preparation should be used as bone graft to supplement bony healing of the fibula.

Surgical Technique

Close

After plate fixation, assess joint stability to external rotation stress testing under fluoroscopic guidance.

- If the syndesmosis shows any tibial fibular diastasis or widening of the medial clear space on gentle stress testing, reduce the syndesmosis and fixate with a 3.5-4.0 screw across four cortices. Screw removal after four months can be considered to allow for anatomic motion of the fibula.

Repair the ATFL and any additional ligament deficit as needed.

Close wound in a routine fashion.

Postoperative Protocol

Individual patient factors and/or adjunctive procedures performed during the operation should be considered in developing a recovery protocol. A suggested protocol is provided below from immediate post-op through week 10.

Post-op (Days 0-14)

Use a well padded splint with the foot in a neutral position.

Initial Post-op Visit

Take radiographs to confirm the implant position.

Place the patient in a walking boot with a rocker sole.

- The boot should be removed for gentle ROM stretching using an appropriate protocol.
- Partial foot-flat with mostly heel weight-bearing for 2-6 weeks.

Second Postop Visit (6 weeks)

Repeat radiographs.

Assess implant position and healing of the fibular osteotomy.

Begin full weight-bearing in the boot brace.

- Delay full weight-bearing in cases with slow fibular healing.
- Continue ROM stretching out of the boot and resistive strengthening exercises.

Week 10

Progressively reduce boot usage as appropriate.

- The patient may use simple supportive ankle soft brace as needed.

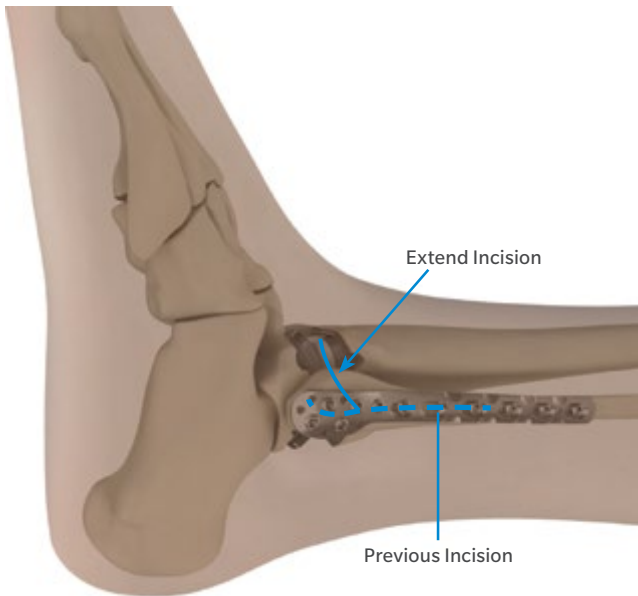

Fig. 99

Poly Revision Procedure

☰ **Note:** The procedure below describes poly revision while maintaining an intact fibula. If difficulty is encountered with this procedure, improve access via fibular osteotomy to aid in completion. Repair the fibula with internal fixation once completed.

☰ **Note:** Use of a distraction device is required for this procedure.

Expose the ankle joint.

- Extend the lateral incision from the primary surgery to expose the dorsal aspect of the joint to ensure full access to the anterior locking mechanism (Fig. 99).
- Expose the anteriolateral capsule through the incision and section the ATFL to create an arthrotomy to the joint.
- Leave a cuff on the ATFL to repair at the end of the procedure.

☰ **Note:** Ensure that the incision avoids the superficial peroneal nerve proximally and distally.

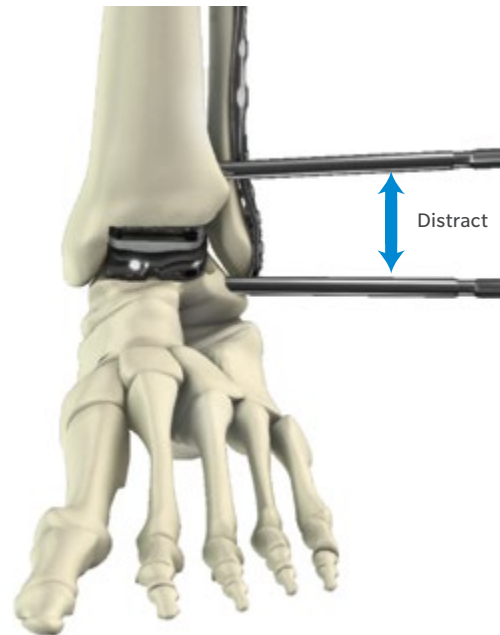

Fig. 100

Assess joint tension.

- Assess joint tension of the in vivo implant prior to removal in order to determine the proper thickness for the replacement Poly Insert.
- Place ankle through range of motion.
- Apply varus and valgus stresses to assess gapping.
- Determine appropriate replacement insert thickness to be used.

Apply distraction to enable poly removal.

- Secure a distraction device to the lateral tibia and talus, taking care to avoid implant structures and allowing for access to the incision.
- Place distraction pins in line with each other, with the Talar Pin close to lateral center of rotation.
- Apply sufficient distraction to allow slight gapping between the Poly Insert and Talar implant (Fig. 100).

Surgical Technique

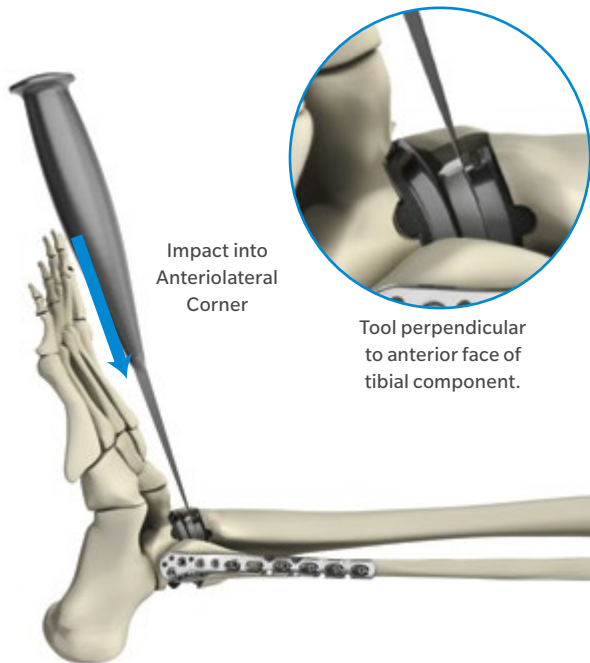

Fig. 101

Insert the Smith/Peterson Osteotome.

- Insert the Osteotome into the anteriolateral face of the Tibial Implant, between the Tibial Base and Poly Insert (Fig. 101).
- Apply a slight impaction force to the Osteotome.
- Be sure that the Osteotome is perpendicular to the anterior face of the tibial component.

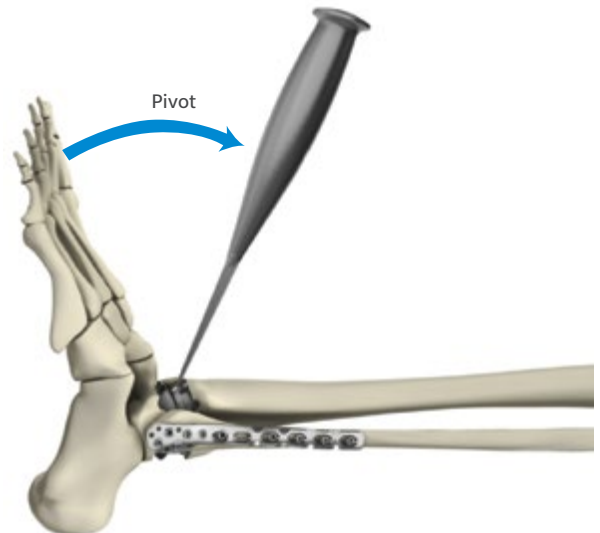

Fig. 102

Disengage the Poly Insert.

- Apply a prying force by pivoting the handle on the Osteotome proximally to disengage the lock (Fig. 102).
- As necessary, move the Osteotome medially and repeat the prying motion until the poly lock is fully disengaged.
- Remove the poly from the joint, taking care to protect the metallic components.

ⓘ **Note:** Once a poly component is removed, it is not intended to be reinserted. A replacement poly component must be used.

🔧 **Technique Tip:** To aid in removal of the Poly Insert, a towel clamp can be used.

Instruments



Osteotome
00-2887-000-01

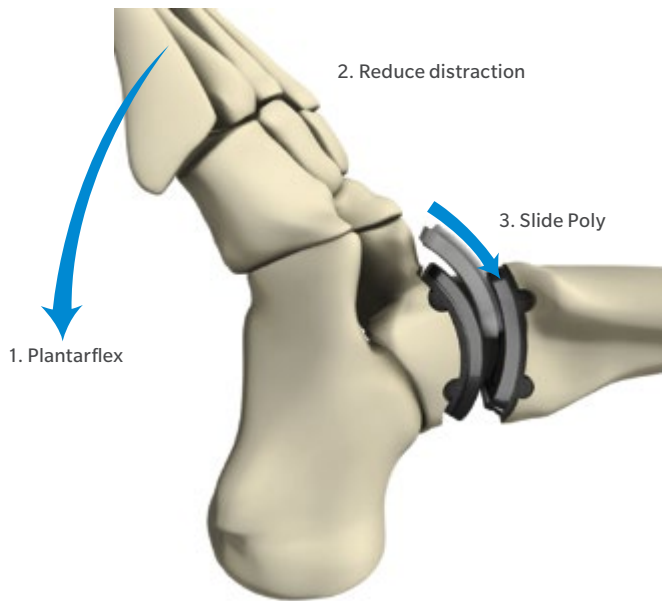

Fig. 103

Carefully clean and inspect the Tibial Base for any damage.

Insert the replacement poly component into the joint (Fig. 103).

- Plantarflex the ankle to improve access.
- Ensure curved edge of the Poly Insert is oriented laterally.
- The non-articulating surface is etched with the Zimmer Biomet logo closest to the lateral edge.
- Reduce distraction to help guide the replacement Tibial Insert into proper position.
- Slide the replacement Poly Insert so that the posterior locking mechanism is engaged by the Tibial Base.

Instruments



Impactor Handle
00-4501-060-02



Poly Revision
Assembly Tool
00-4501-067-01



Revision Protective
Sleeve
00-4501-067-03

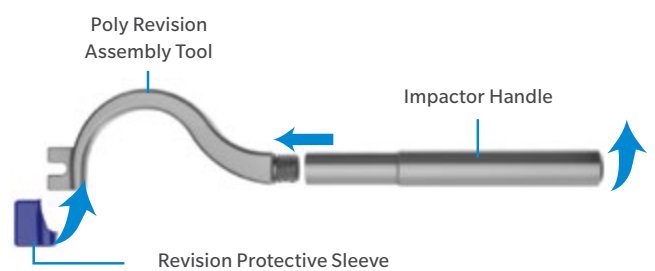

Fig. 104

Technique Tip: Place a finger on the skin posterior to the tibial component to prevent the Tibial Insert from advancing beyond the locking mechanism.

Assemble the Poly Revision Assembly Tool.

- Assemble the Poly Revision Assembly Tool to the Impactor Handle (Fig. 104).
- Place the Revision Protective Sleeve over the Poly Revision Assembly Tool to protect the poly from being scratched.

Surgical Technique

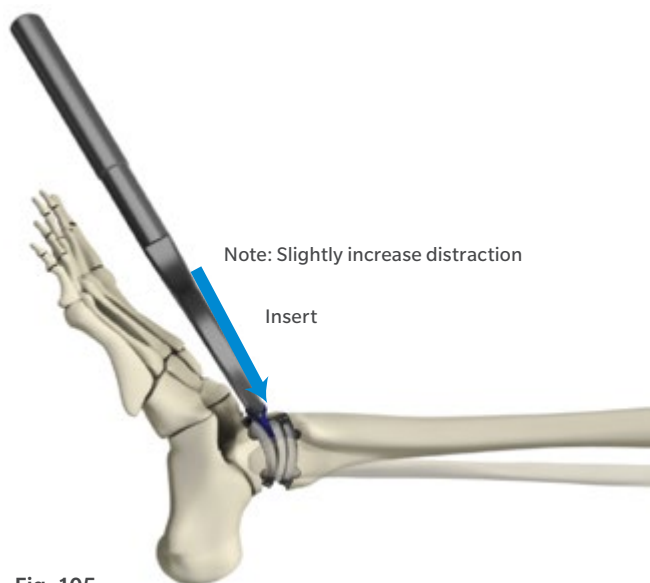

Fig. 105

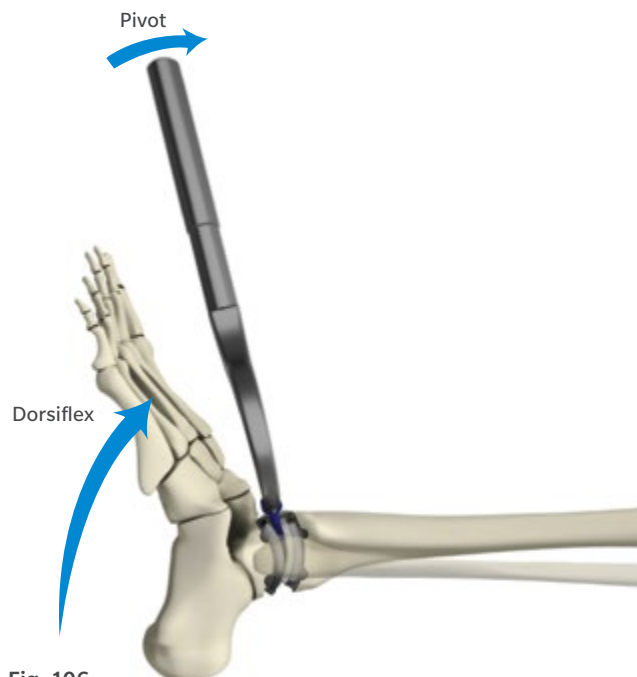

Fig. 106

Fully assemble the Poly Insert into the Tibial Base.

- Place the Poly Revision Assembly Tool between Talar component and the replaced Poly Insert (Fig. 105).
- Apply minimal distraction as needed.
- Pivot the Poly Revision Assembly Tool proximally until the Poly Insert engages with an audible or palpable click (Fig. 106).
- Dorsiflex the ankle and reduce distraction to aid in this procedure.
- Inspect along the entire visible perimeter of the poly and tibial base to ensure that the poly is fully seated.

ⓘ **Note:** If difficulty is encountered with assembling the Poly Insert to the Tibial Base, improve access via fibular osteotomy to aid in completion. Repair the fibula with internal fixation once completed.

ⓘ **Note:** If there is uncertainty regarding the full engagement of the posterior locking mechanism, extend the incision and dissection to allow for direct visualization of the posterior tibial component to confirm locking. Consider fibular osteotomy to aid in fully seating the posterior locking mechanism.

Prepare for closure.

- Wash joint with pulsating lavage.
- Remove any debris from the ankle joint and surrounding areas.
- Repair the ATFL.

Close the wound in a routine fashion.

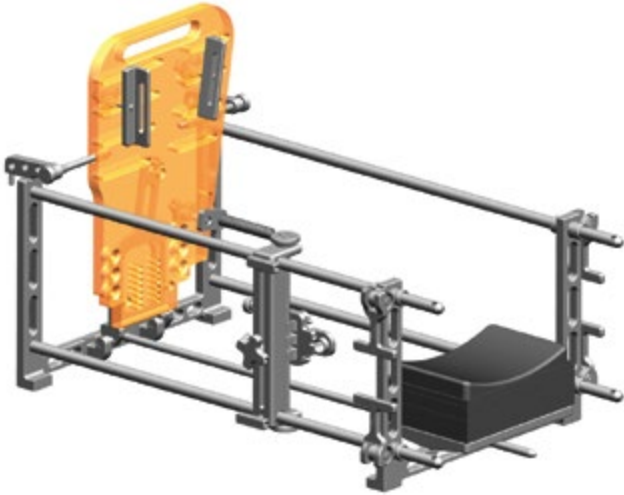

Fig. 107 Left Ankle

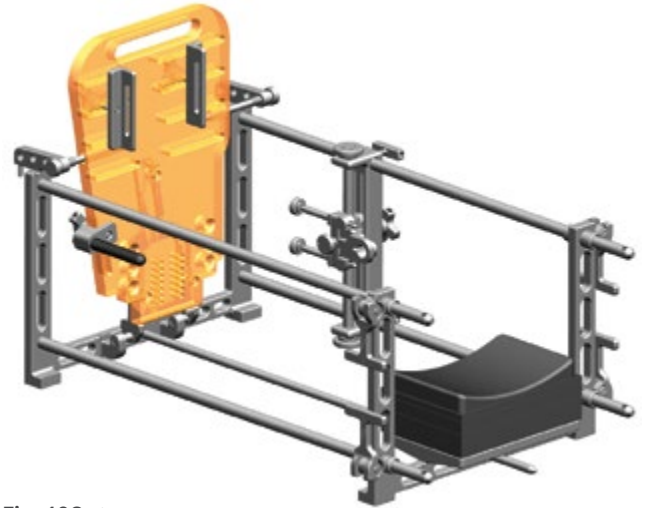

Fig. 108 Right Ankle

Appendix A:

Alignment Stand Assembly

This section will detail how to assemble the Assembly Stand, which should be done at the back table, and moved to the operating table after initial incision has been performed.

- ⓘ **Note:** Positioning of the Foot Plate, Talar Pin Connector and Lateral Cut Guide Assembly is different, depending on whether the surgery is performed on a left (Fig. 107) or a right ankle (Fig. 108). Left orientation is presented in these instructions.

Surgical Technique

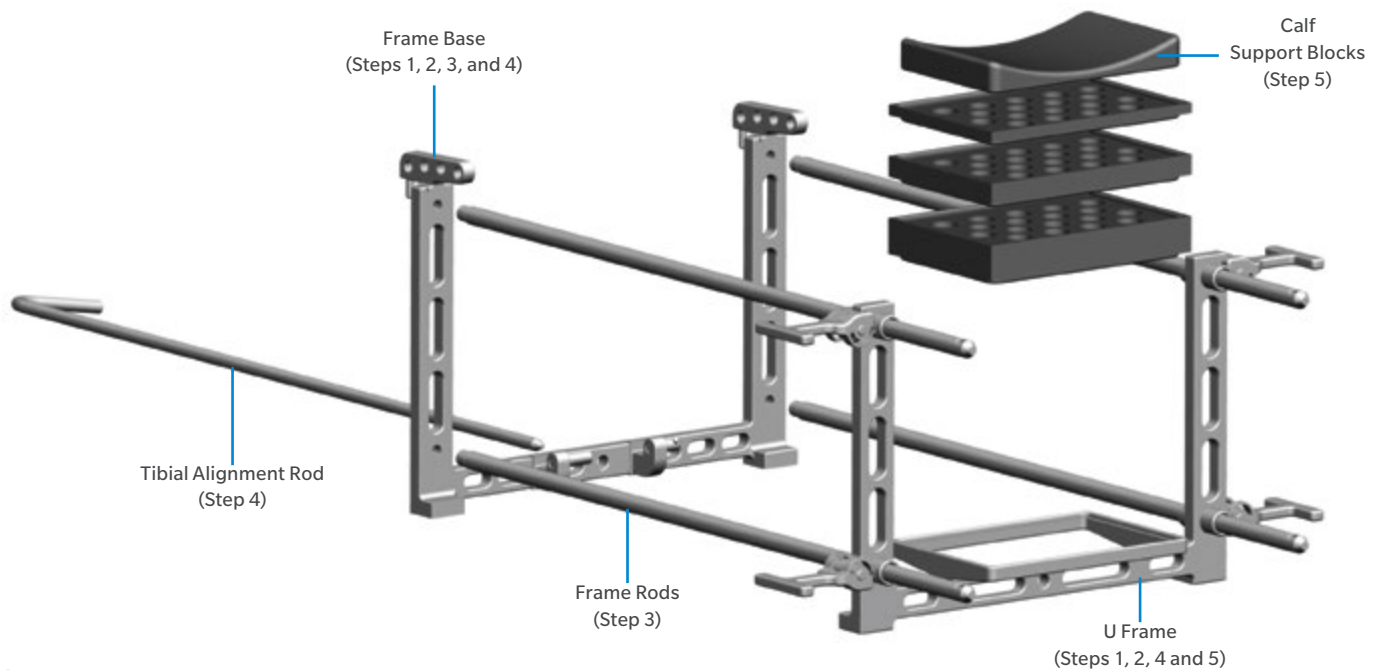

Fig. 109

Step 1

Set the U Frame and Frame Base upright and parallel on a table (Fig. 109).

- The hinges on the Frame Base should point toward the U Frame.
- The lever fasteners on the U Frame should be in the unlocked position (parallel to the floor).

Step 2

Insert the four Frame Rods through the holes on the U Frame (Fig. 109).

The threaded ends should point toward the Frame Base.

Step 3

Thread the threaded ends of the four Frame Rods into the corresponding holes of the Frame Base until tight (Fig. 109).

Step 4

Insert the Tibial Alignment Rod through the center hole at the bottom of the Frame Base and extend it across the Alignment Stand Assembly and through the corresponding hole at the bottom of the U Frame (Fig. 109).

Step 5

- Stack the desired number of interlocking Calf Support Blocks onto the cradle at the bottom of the U Frame to achieve the desired height (Fig. 109).
- Use the concave Calf Support Top as the final block.

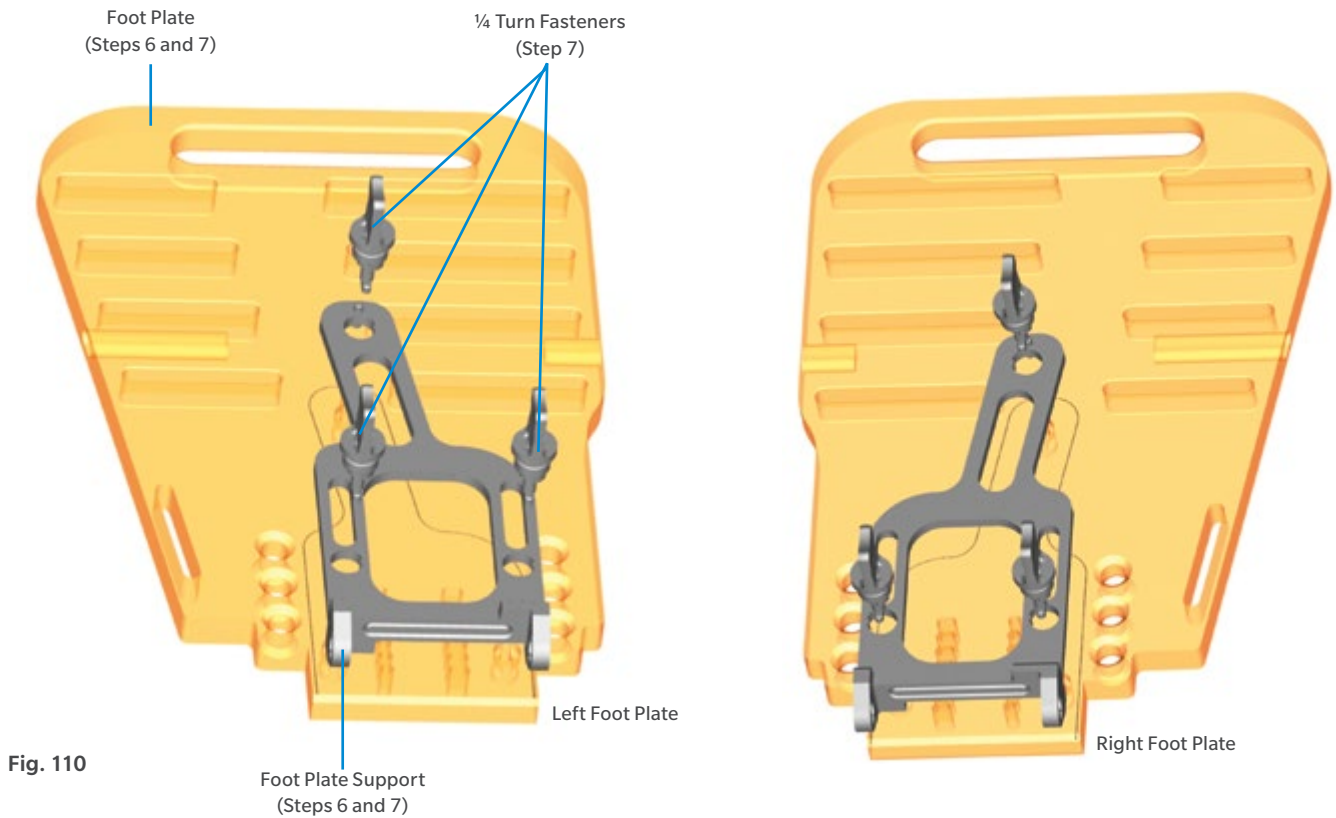

Step 6

Set the Foot Plate flat on the table and place the Foot Plate Support over the silhouette outline (Fig. 110).

Ensure that the proper “RIGHT” or “LEFT” indication is facing up on both the Foot Plate and the Foot Plate Support.

The peg on the Foot Plate Support should fit into the corresponding hole on the Foot Plate.

Step 7

Insert a ¼ Turn Fastener through each of the three holes in the Foot Plate Support and Foot Plate, and rotate each fastener one quarter turn (Fig. 110).

Surgical Technique

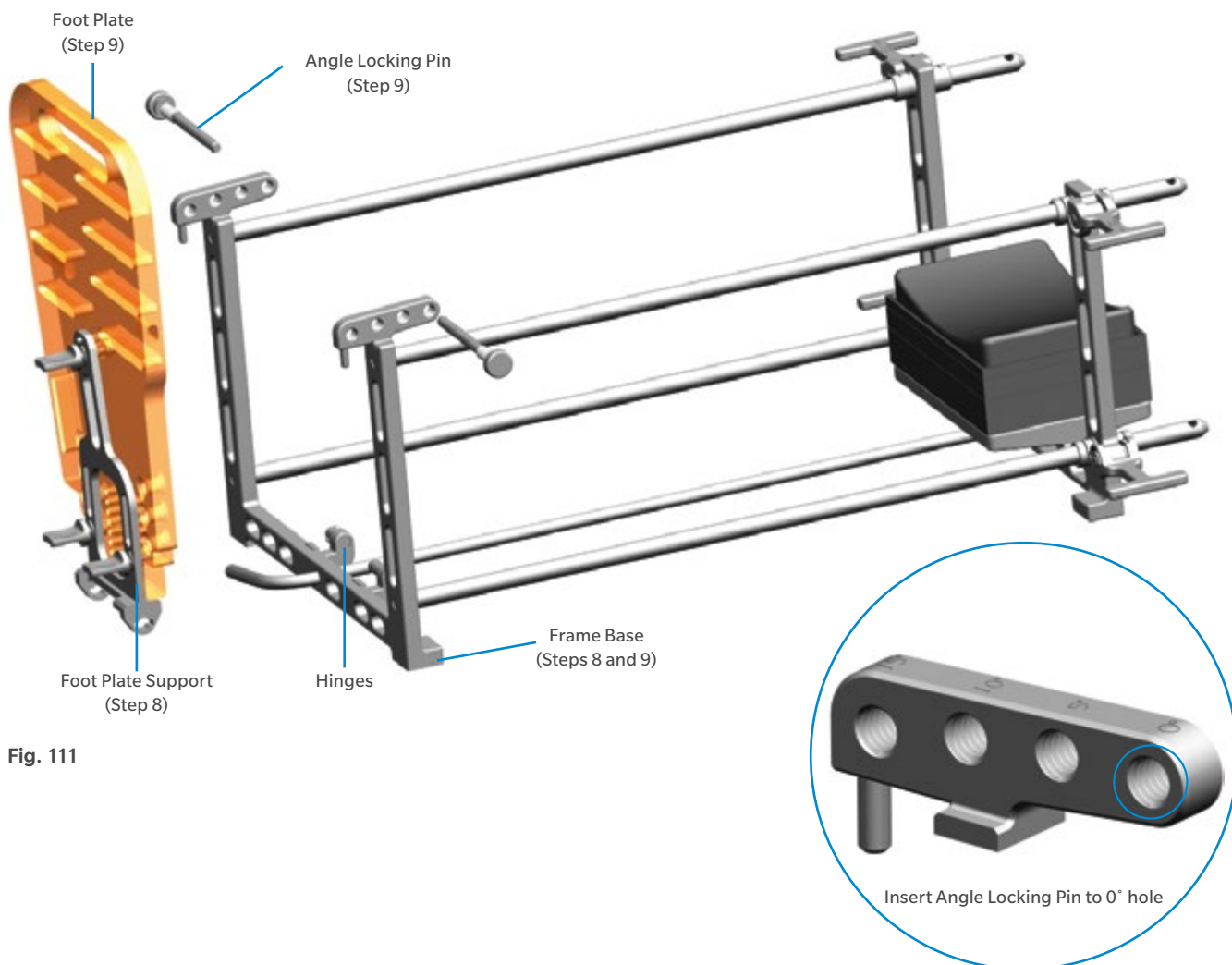

Fig. 111

Step 8

Slide the end of the Foot Plate assembly onto the hinges on the bottom of the Frame Base (Fig. 111).

Ensure that the Foot Plate Support is facing away from the frame assembly.

Step 9

Rotate the Foot Plate assembly upward and insert an Angle Locking Pin through each hole marked "0°" on the locking block of the Frame Base (Fig. 111 Inset). Thread the pins into the Foot Plate.

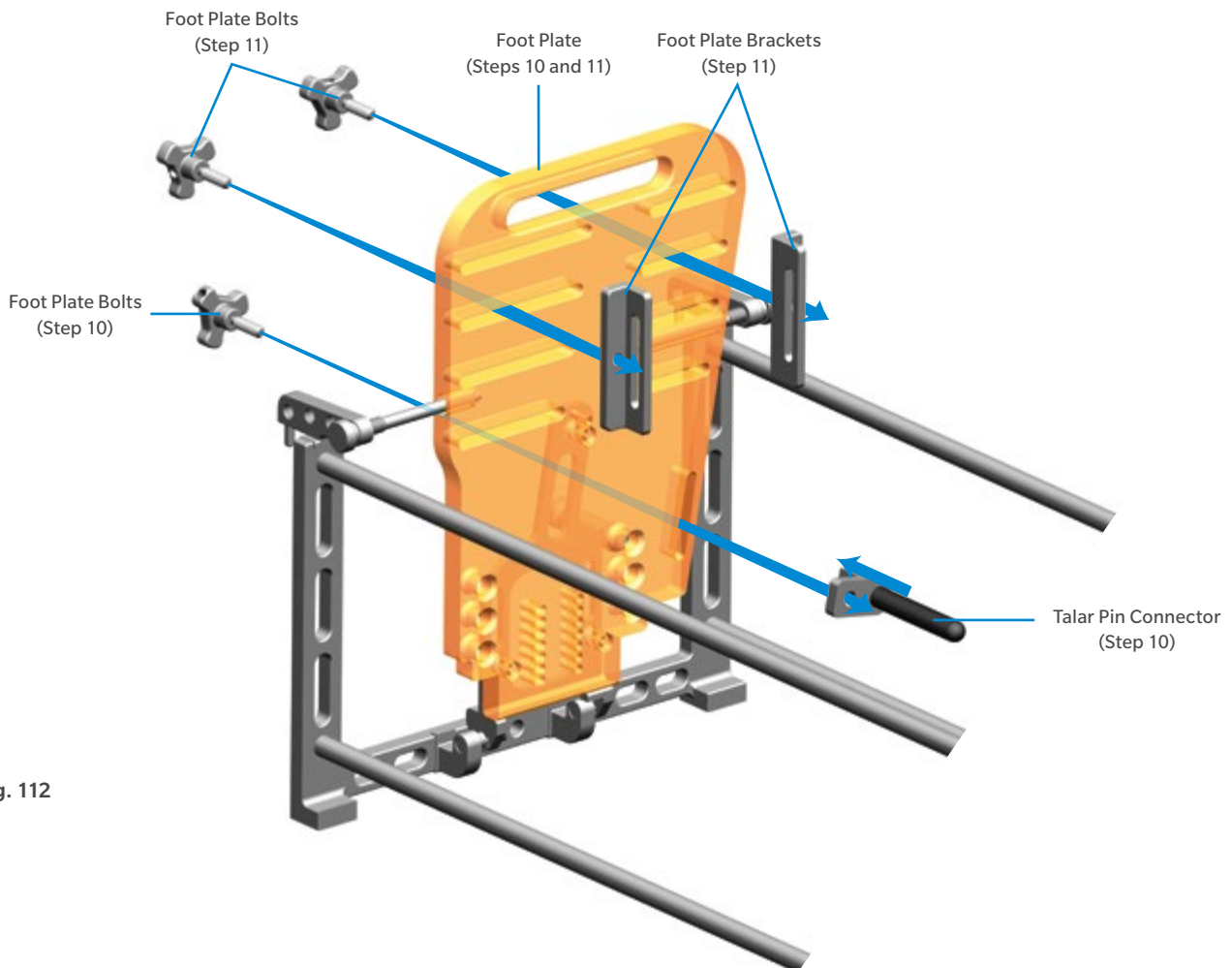

Fig. 112

Step 10

Attach the Talar Pin Connector to the medial side of the Foot Plate by inserting a Foot Plate Bolt through the vertical slot near the bottom of the Foot Plate, and threading it into the Talar Pin Connector (Fig. 112).

The Foot Plate Bolts have three lobes on the knob.

Step 11

Attach the two Foot Plate Brackets to the Foot Plate by inserting Foot Plate Bolts through the appropriate horizontal slots on the back of the plate, and threading them into the brackets (Fig. 112).

Surgical Technique

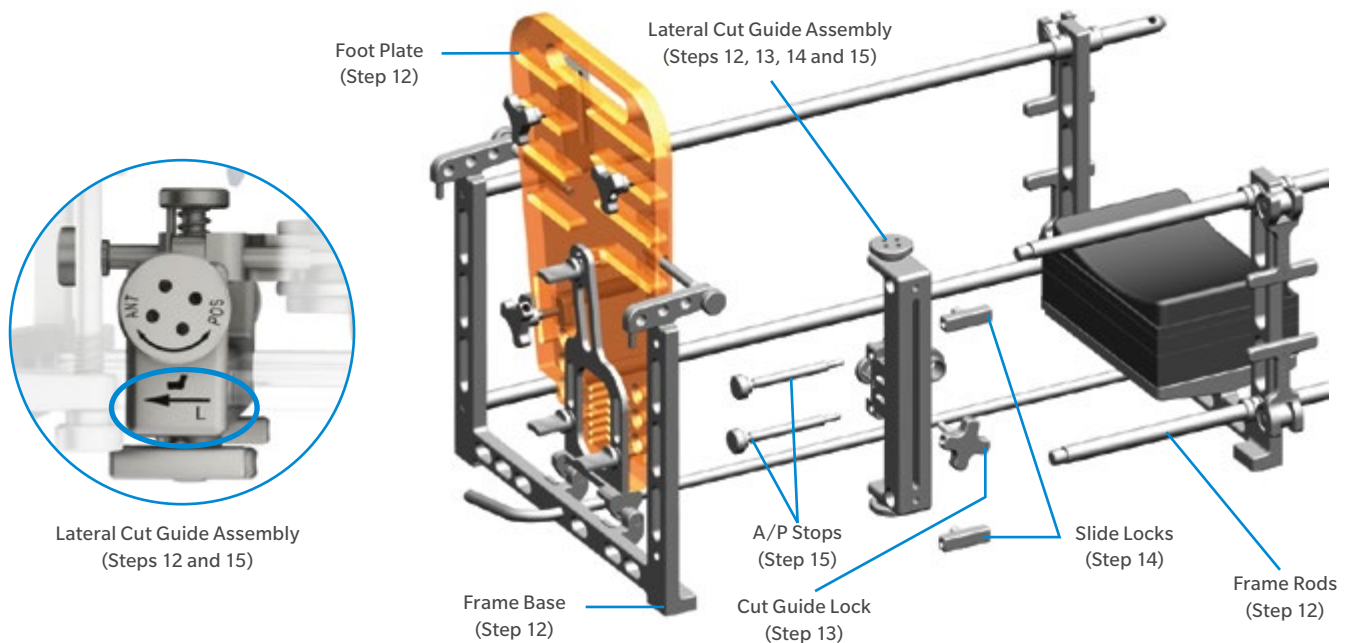

Fig. 113

Step 12

Unthread the two Frame Rods that will be on the lateral side of the patient's foot, and slide the Lateral Cut Guide Assembly onto the Frame Rods (Fig. 113). Then rethread the two Frame Rods back into the Frame Base.

- Ensure that the appropriate "L" or "R" indication is facing up and the arrow is pointed toward the Foot Plate (Fig. 113 inset).
- The Lateral Cut Guide Assembly slides best when the force is applied at the oval etch mark on the guide.

Technique Tip: To facilitate loosening of the Frame Rods, it may be helpful to insert a pin through the hole on the blunt end of each Frame Rod.

Step 13

Insert and thread the Cut Guide Lock through the slot in the Lateral Cut Guide Assembly (Fig. 113).

- The Cut Guide Lock has four lobes on the knob.

Step 14

Thread 2 Slide Locks into the bottom and top holes of the Lateral Cut Guide Assembly (Fig. 113).

- The Slide Locks have two lobes on the knob.

Step 15

Thread the two A/P Stops into the two distal holes on the ankle side of the Lateral Cut Guide Assembly until they appear through the opposite end of the holes (Fig. 113).

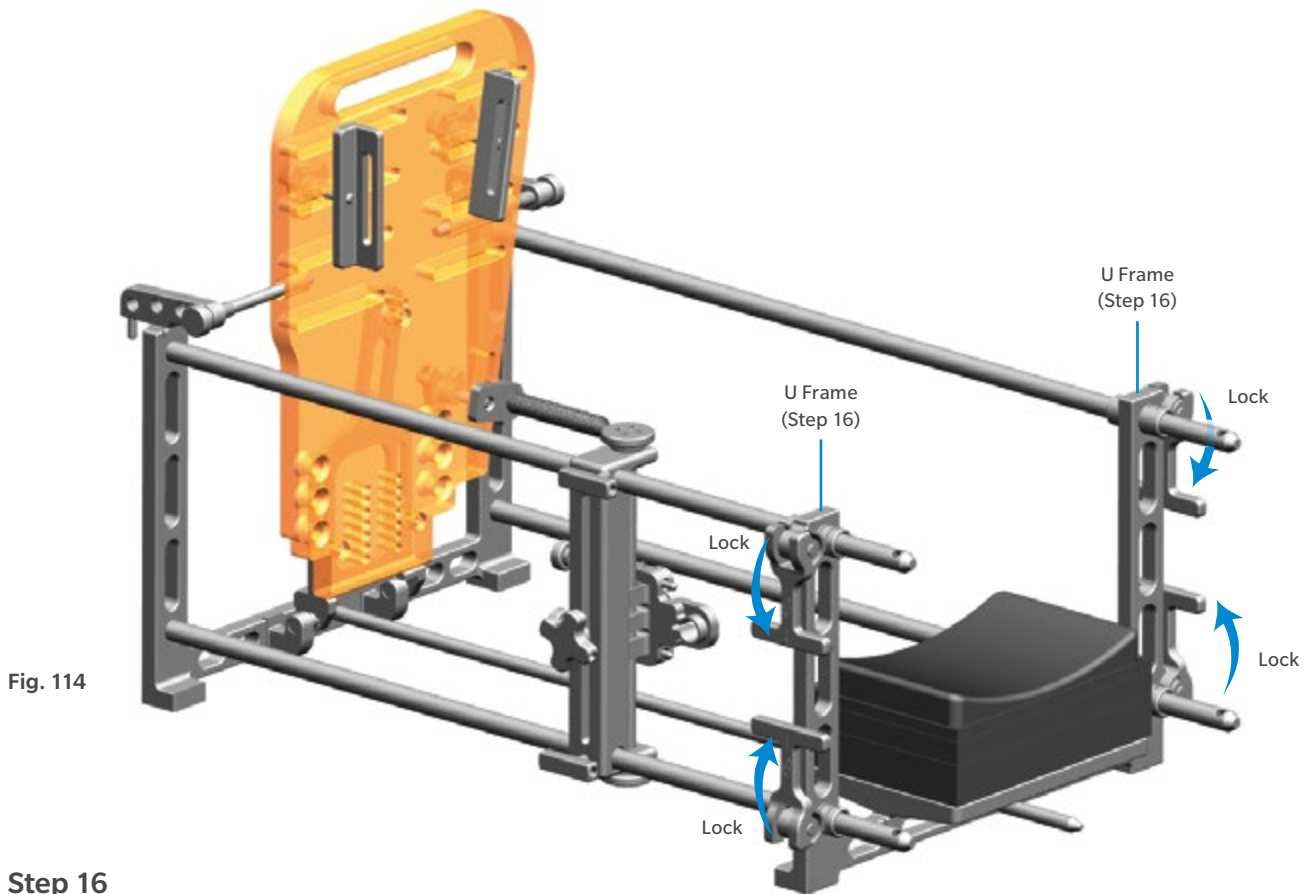

Fig. 114

Step 16

Lock the U Frame by rotating the four lever fasteners inward until they snap into place (Fig. 114).

Assembly is now complete.

⊞ **Note:** Disassemble the Alignment Stand before cleaning and sterilization.

Surgical Technique

Indications

Total ankle arthroplasty is intended to provide a patient with limited mobility by restoring alignment, reducing pain and preserving the flexion/extension movement within the ankle joint.

The Zimmer Trabecular Metal Total Ankle is indicated as a total ankle replacement in primary or revision surgery for patients with:

- Rheumatoid arthritis.
- Post-traumatic arthritis.
- Degenerative arthritis.

This device is intended for uncemented or cemented use.

Contraindications

- Local/Systemic infection that may affect the prosthetic joint.
- Previous history of infection in the affected joint is a relative contraindication.
- Insufficient bone stock or bone quality.
- Skeletal immaturity.
- Severe instability, maltracking or misalignment of the tibia and talus (unless correctable by surgery).
- Charcot's disease.
- Loss of musculature or neuromuscular compromise in the affected limb.
- Severe osteoporosis.
- Severe neurological or vascular disease affecting the extremity.
- Ankle arthrodesis with malleolar exeresis.

This material is intended for health care professionals. Distribution to any other recipient is prohibited. For product information, including indications, contraindications, warnings, precautions, potential adverse effects and patient counseling information, see the package insert and www.zimmerbiomet.com.

Zimmer Biomet does not practice medicine. This technique was developed in conjunction with health care professionals. This document is intended for surgeons and is not intended for laypersons. Each surgeon should exercise his or her own independent judgment in the diagnosis and treatment of an individual patient, and this information does not purport to replace the comprehensive training surgeons have received. As with all surgical procedures, the technique used in each case will depend on the surgeon's medical judgment as the best treatment for each patient. Results will vary based on health, weight, activity and other variables. Not all patients are candidates for this product and/or procedure.

All content herein is protected by copyright, trademarks and other intellectual property rights, as applicable, owned by or licensed to Zimmer Biomet or its affiliates unless otherwise indicated, and must not be redistributed, duplicated or disclosed, in whole or in part, without the express written consent of Zimmer Biomet.

Caution: Federal (USA) law restricts this device to sale by or on the order of a surgeon. Rx only.

©2017 Zimmer Biomet



Authorized Representative

Zimmer U.K. Ltd.
9 Lancaster Place
South Marston Park
Swindon, SN3 4FP
United Kingdom



ZIMMER BIOMET
Your progress. Our promise.™



Legal Manufacturer
Zimmer, Inc.
1800 W Center Street
Warsaw, IN 46580
USA

www.zimmerbiomet.com

CE0086

CE mark on a surgical technique is not valid unless there is a CE mark on the product label.