

**S.** Det är lampligt att denna information överlämnas till användaren av anläggningen.  
**GB.** It is appropriate that this information is passed on to the user of the installation.  
**D.** Diese Informationen sind für den Benutzer der Anlage vorgesehen.  
**SF.** Tämä ohje on suositeltava luovuttaa.

# Montageanvisning Hood Mini E27 pendel

## Assembly instruction Hood Mini E27 pendant

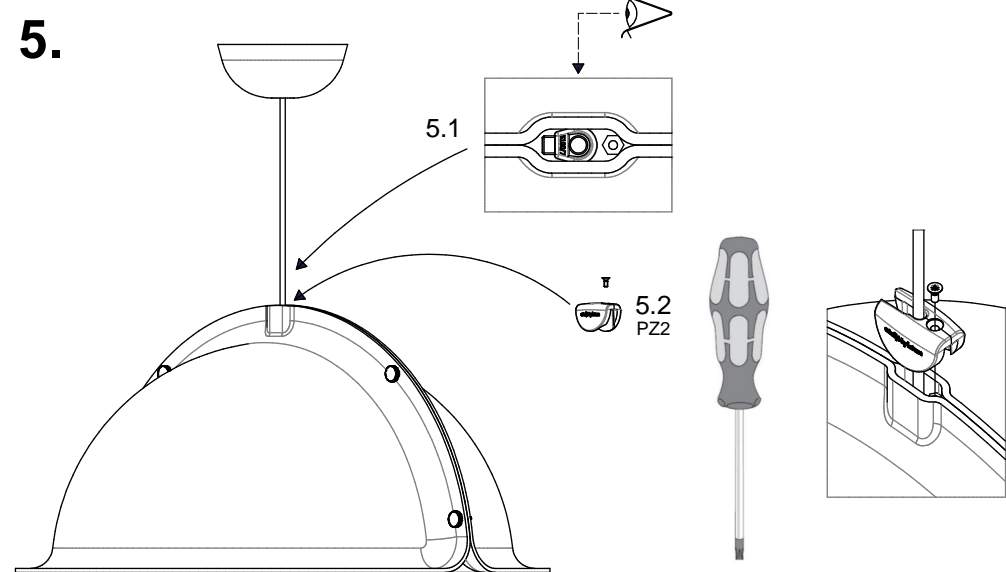
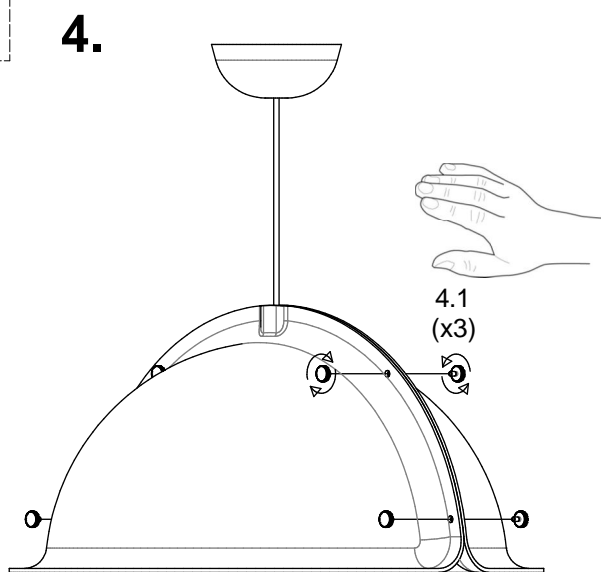
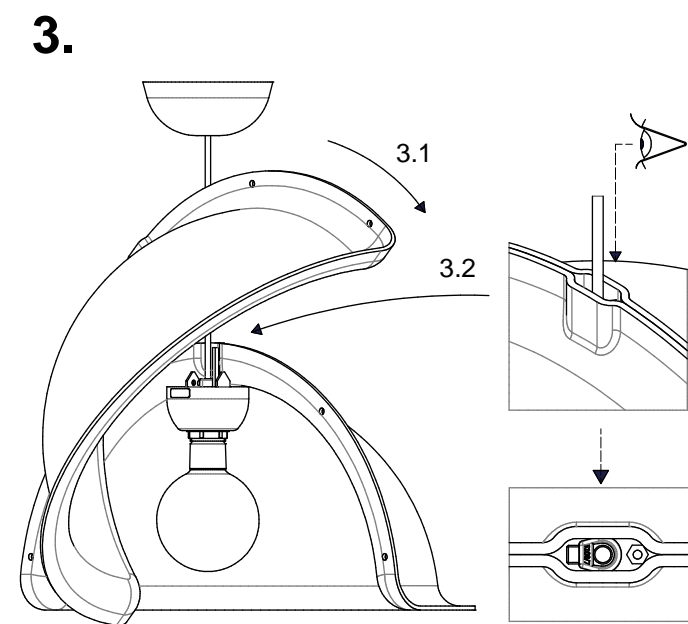
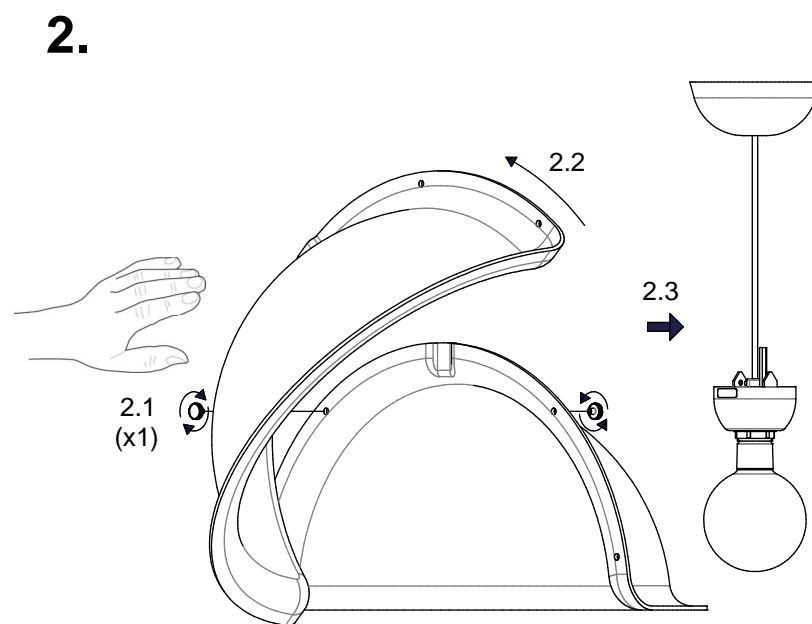
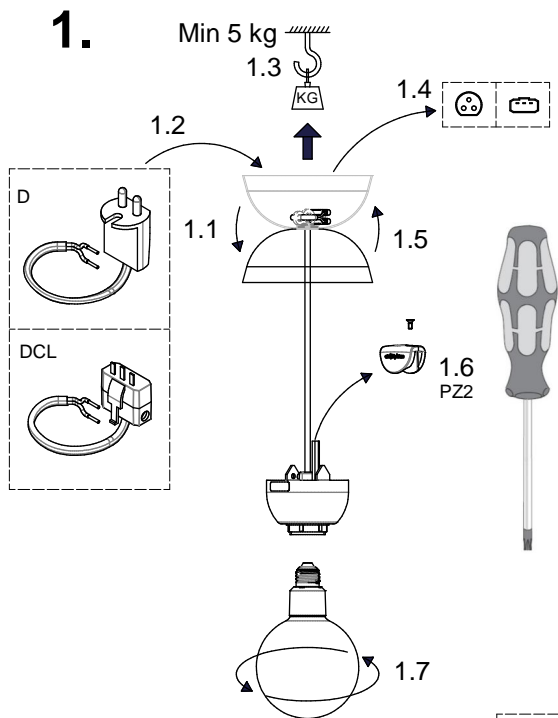

**S.** Om armaturens kabel skulle skadas eller om armaturen inte fungerar som den ska, skall dessa komponenter kontrolleras/bytas av tillverkaren eller av tillverkaren utsedd person.

**GB.** If the luminaire cable is damaged or if the luminaire is not working properly, it shall exclusively be checked/replaced by the manufacturer or by the manufacturer designated person.

# Montageanvisning Hood Mini Pro pendel

## Assembly instruction Hood Mini Pro pendant

**S.** Det är lämpligt att denna information överlämnas till användaren av anläggningen.  
**GB.** It is appropriate that this information is passed on to the user of the installation.

**D.** Diese Informationen sind für den Benutzer der Anlage vorgesehen.  
**SF.** Tämä ohje on suositeltava luovuttaa.

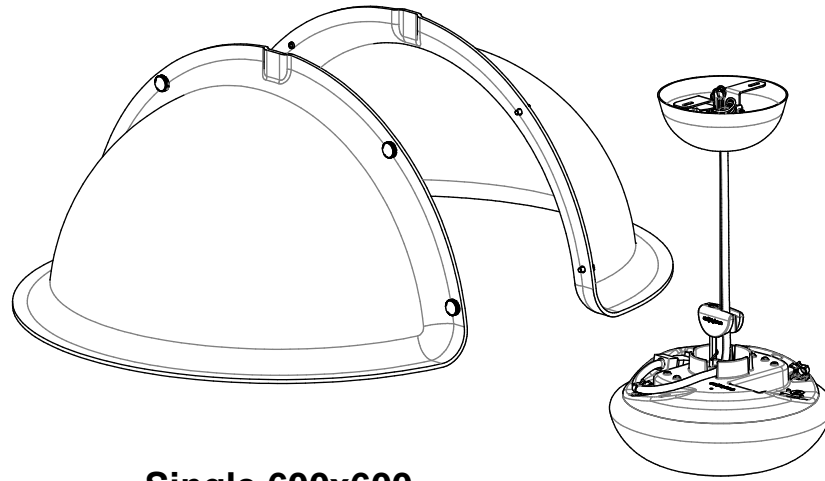

**Single 600x600**

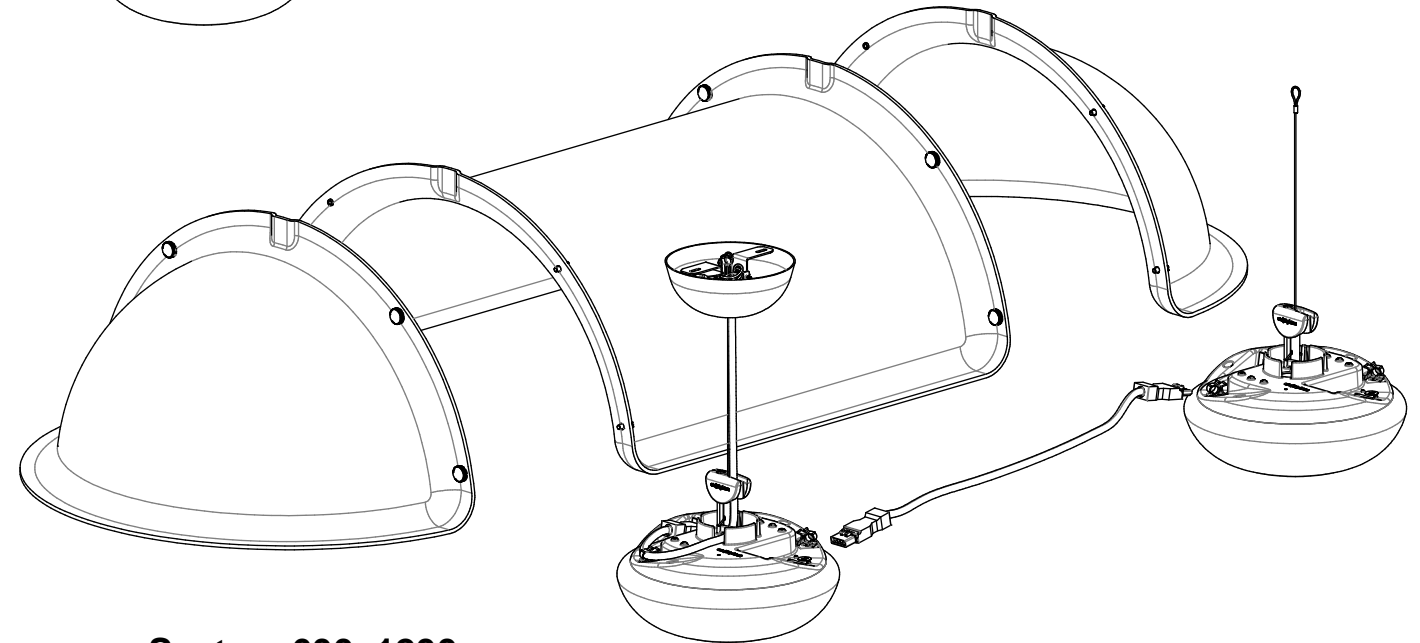

**System 600x1200**



**S.** Om armaturens kabel skulle skadas eller om armaturen inte fungerar som den ska, skall dessa komponenter kontrolleras/bytas av tillverkaren eller av tillverkaren utsedd person.

**GB.** If the luminaire cable is damaged or if the luminaire is not working properly, it shall exclusively be checked/replaced by the manufacturer or by the manufacturer designated person.



"The lightsource shall only be replaced by the manufacturer or his designated person"  
 "Ljuskällan ska enbart bytas ut av tillverkaren eller hans utsedd person"

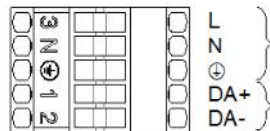

**S** Grundläggande isolering mellan nät och styrledning  
**GB** Basic insulation between mains and control wiring

**S.** Det är lämpligt att denna information överlämnas till användaren av anläggningen.  
**GB.** It is appropriate that this information is passed on to the user of the installation.  
**D.** Diese Informationen sind für den Benutzer der Anlage vorgesehen.  
**SF.** Tämä ohje on suositeltava luovuttaa.

# Montageanvisning Hood Mini Pro - Ljusmotor

## Assembly instruction Hood Mini Pro - Light engine

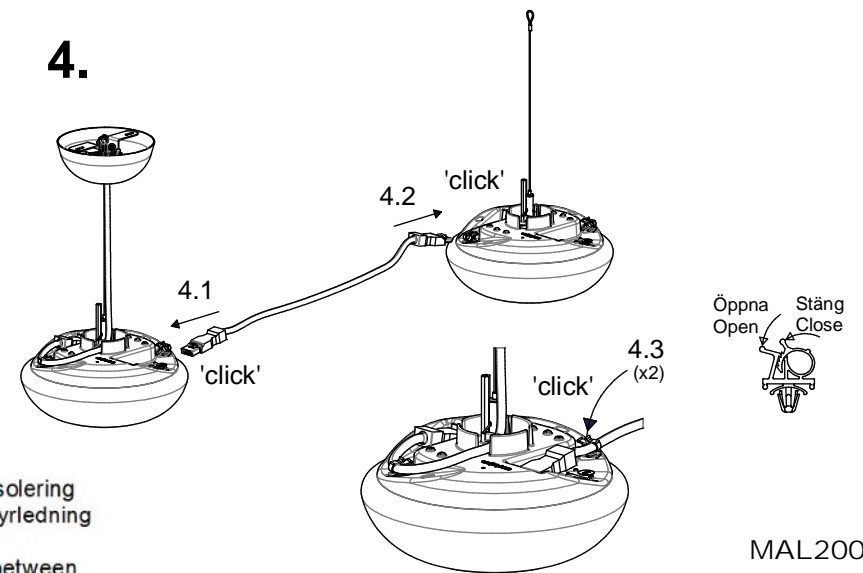
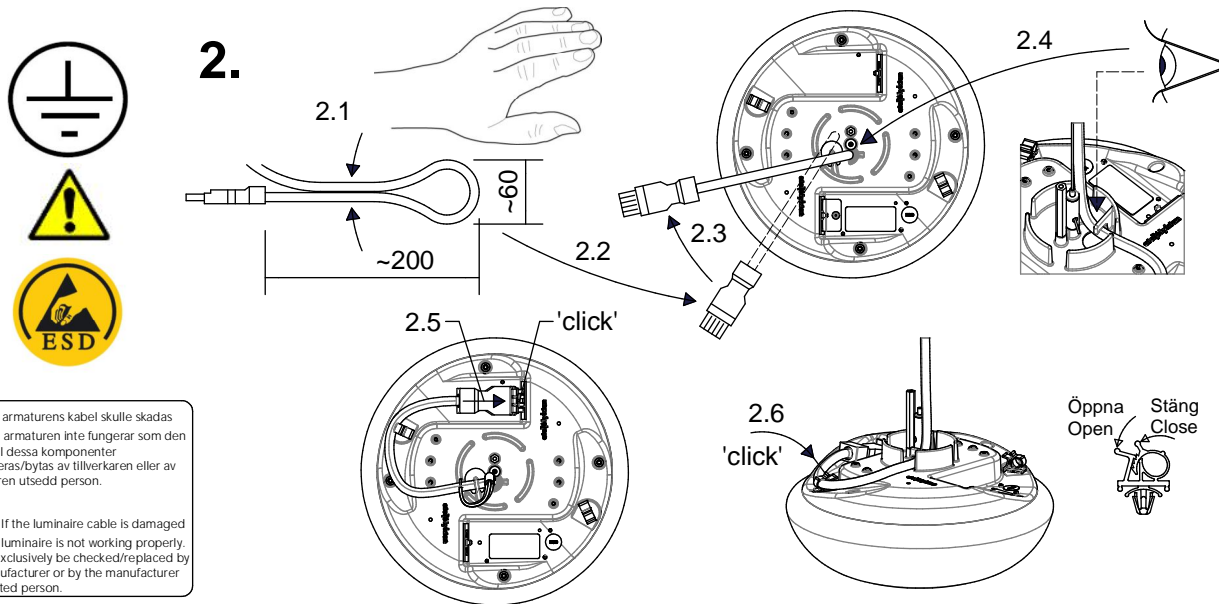
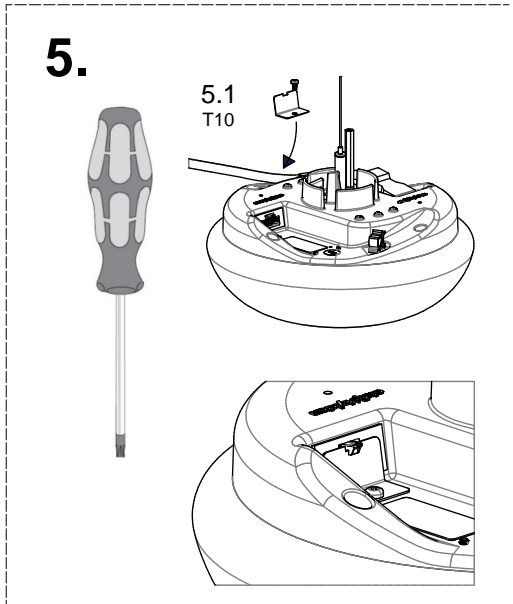
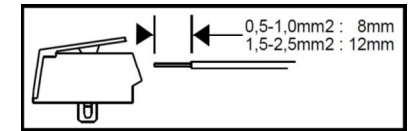
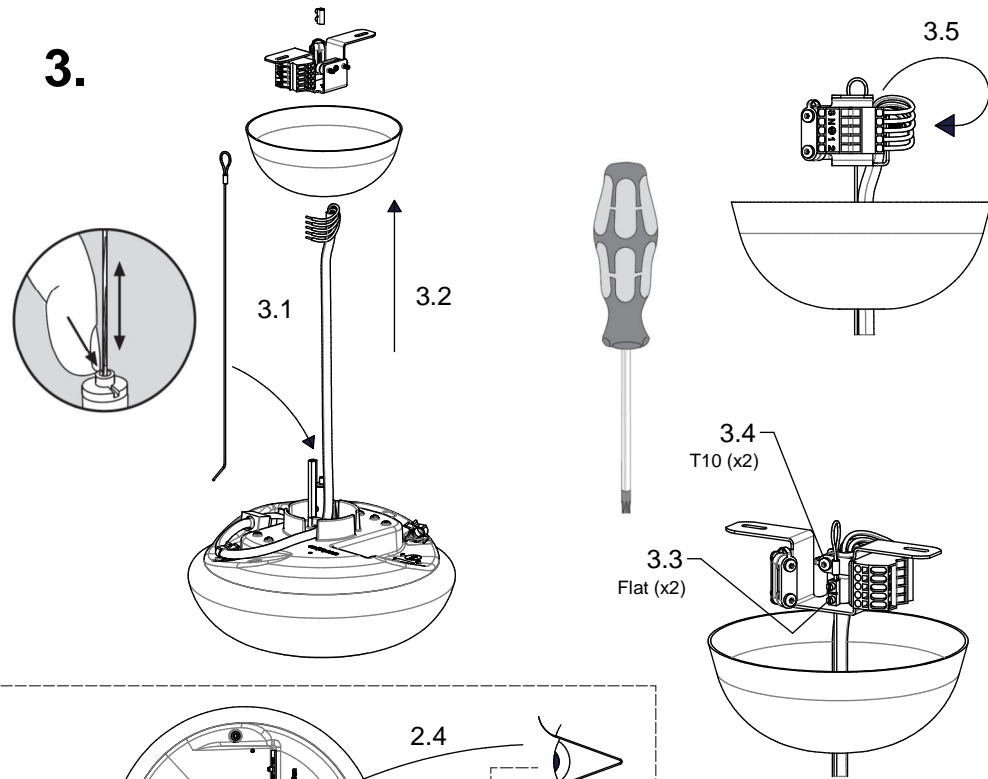
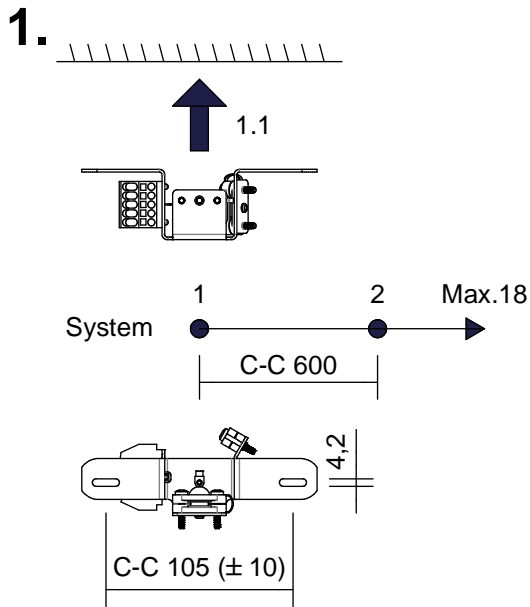

**S.** Om armaturens kabel skulle skadas eller om armaturen inte fungerar som den ska, skall dessa komponenter kontrolleras/bytas av tillverkaren eller av tillverkaren utsedd person.  
**GB.** If the luminaire cable is damaged or if the luminaire is not working properly, it shall exclusively be checked/replaced by the manufacturer or by the manufacturer designated person.

"The lightsource shall only be replaced by the manufacturer or his designated person"  
 "Ljuskällan ska enbart bytas ut av tillverkaren eller hans utsedd person"

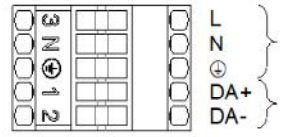

**S** Grundläggande isolering mellan nät och styrledning  
**GB** Basic insulation between mains and control wiring

**ateljé Lyktan**  
 SE-296 81 Åhus, Sweden  
 Tel: +46 44 28 98 00  
 Fax: +46 28 98 38  
 info@ateljje-lyktan.se  
 www.ateljje-lyktan.se

**S.** Det är lämpligt att denna information överlämnas till användaren av anläggningen.  
**GB.** It is appropriate that this information is passed on to the user of the installation.

**D.** Diese Informationen sind für den Benutzer der Anlage vorgesehen.  
**SF.** Tämä ohje on suositeltava luovuttaa.

# Montageanvisning Hood Mini Pro - Skärmar

## Assembly instruction Hood Mini Pro - Shades

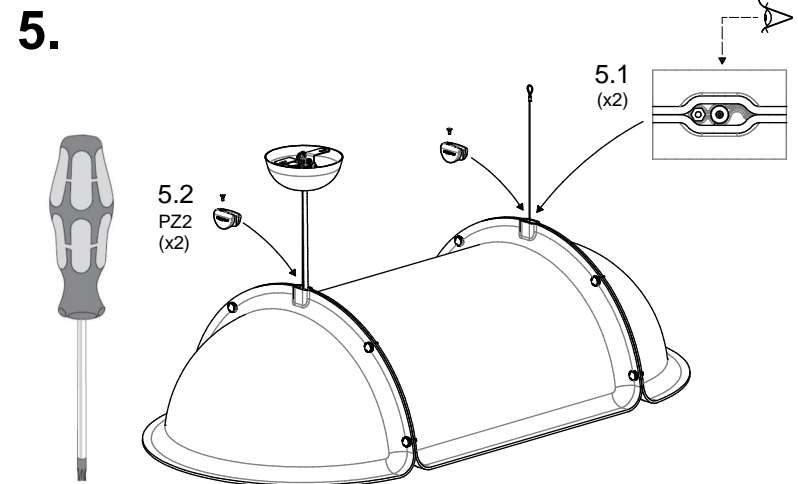
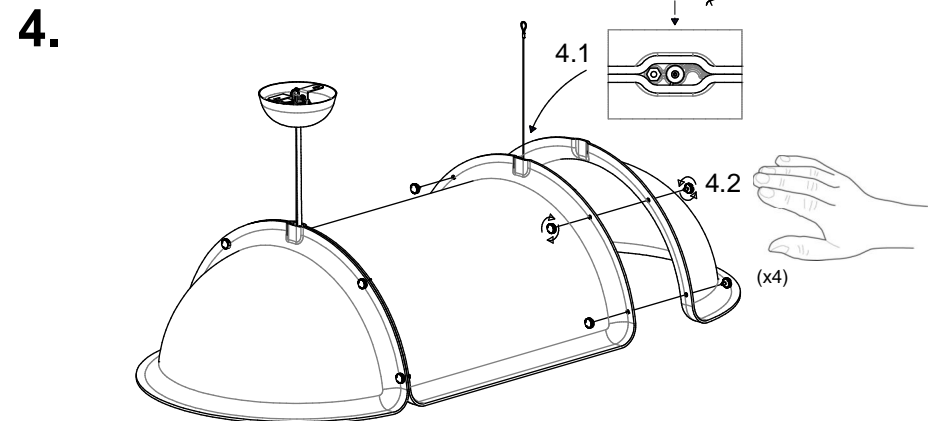
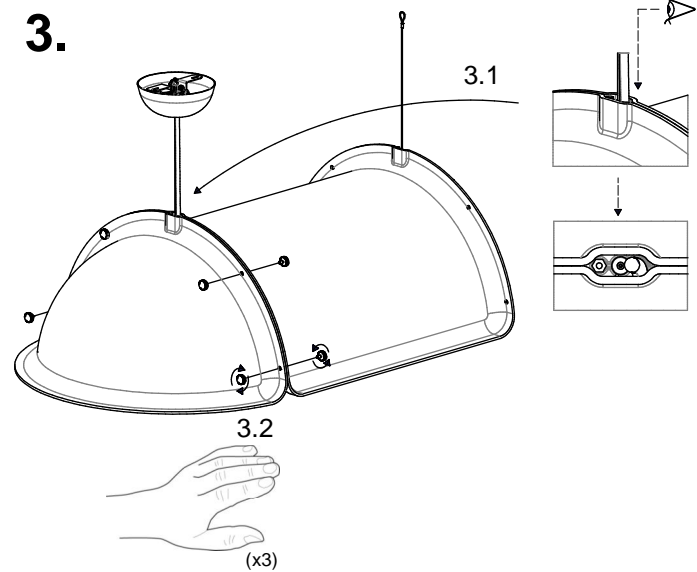
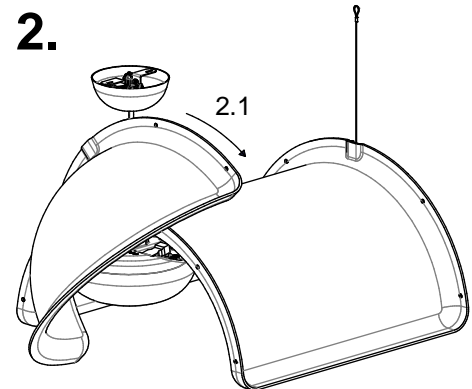
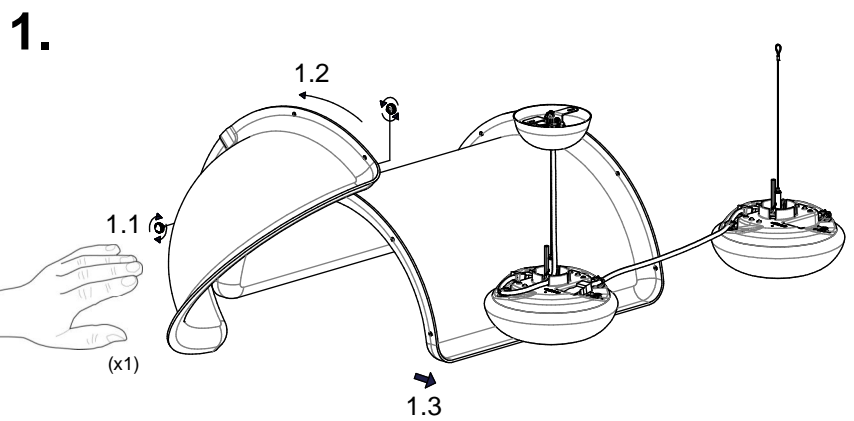

**S.** Om armaturens kabel skulle skadas eller om armaturen inte fungerar som den ska, skall dessa komponenter kontrolleras/bytas av tillverkaren eller av tillverkarens utsedd person.  
**GB.** If the luminaire cable is damaged or if the luminaire is not working properly, it shall exclusively be checked/replaced by the manufacturer or by the manufacturer designated person.



"The lightsource shall only be replaced by the manufacturer or his designated person"  
 "Ljuskällan ska enbart bytas ut av tillverkaren eller hans utsedd person"

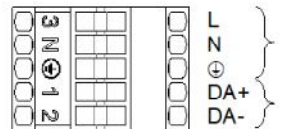

**S** Grundläggande isolering mellan nät och styrledning  
**GB** Basic insulation between mains and control wiring

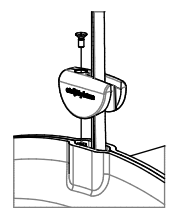

**ateljé Lyktan**  
 SE-296 81 Åhus, Sweden  
 Tel: +46 44 28 98 00  
 Fax: +46 28 98 38  
 info@ateljje-lyktan.se  
 www.ateljje-lyktan.se