



INTERIOR LIGHTING



ANTIMICROBIAL LIGHT

Powered by Vyv

The Antimicrobial Light provides effective illumination and kills¹ viruses, bacteria, fungi, yeasts and mould. This includes killing² 98% of SARS-CoV-2. Additional features include easy installation and wiring, clear polycarbonate lens, bright/dim modes and a compact flush-mount design.

¹ Testing on a non-enveloped virus (MS2 bacteriophage) showed a 97.12% reduction in controlled laboratory testing in 8 hours on hard surfaces. Testing on SARS-CoV-2 (enveloped virus) showed a 96.76% reduction in controlled laboratory testing in 8 hours on hard surfaces. Testing on MRSA and E. coli showed 90%+ reduction in controlled laboratory testing in 24 hours on hard surfaces.

² Testing on SARS-CoV-2 (enveloped virus) showed a 98.45% reduction in controlled laboratory testing in 4 hours on hard surfaces.

^{1,2} Results may vary depending on the amount of light that is reaching the surfaces in the space where the product is installed and the length of time of exposure. Use of Vyv antimicrobial light is not intended to replace manual cleaning and disinfection practices.

Models

PART NO.	VOLTS AMPS	LEDS	CONNECTOR
PCL-LED-VV-E	12-24 1.5	48	Bare Leads

Features and Benefits

- Features a tough polycarbonate lens and easy installation with a flush-mount design
- Vyv technology kills¹ viruses, bacteria, fungi, yeasts and mould
- Creates an inhospitable environment for bacteria and microbe growth while providing effective white lighting for use around people and animals
- Fits in a standard 7.0" / 178mm cutout
- For optimal antimicrobial capability, replace all passenger area lighting fixtures with Antimicrobial Light devices
- Internationally certified by IEC 62471

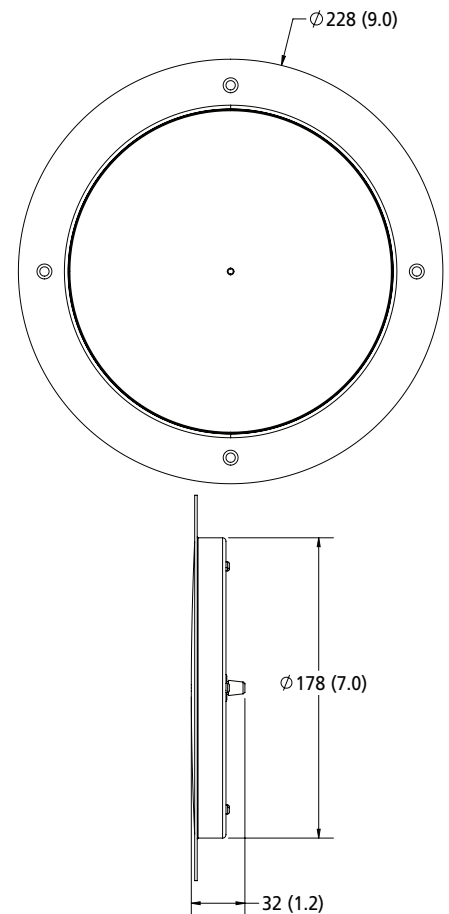

Measurements in millimetres (inches)

+44 (0)113 237 5340 | sales@eccogroup.com