

prestige

Fully Condensing Water Boiler



Engineering Submittal Solo 250



- Digital display control panel
- Use of 3" PVC, CPVC or AL29-4C pipe for vent and air up to 30 equivalent feet each or 4" up to 60 equivalent feet each (total length and fittings – each 90° elbow equals 5 feet and each 45° elbow equals 3 feet)
- Limited 10 year warranty
- Boost feature for low temperature startup
- Light weight construction for wall mounting
- Standard equipment:
 - ASME 30 psi pressure relief valve
 - pressure and temperature gauge
 - high limit temperature safety control
 - outdoor temperature reset control
 - air vent
 - 24 volt terminal strip with removable jumpers for manual reset or automatic reset
 - automatic low water cutoff feature
 - variable speed blower
- Microprocessor electronic gas and air controller
- Stainless steel premix burner
- Reliable spark ignition
- Unique geometry – 3 consecutive baffles guide water flow through the heat exchanger and around the combustion chamber
- High water content – stable temperature control and less sensitive to water flow
- Electronic controls with easy to read menus, performance and trouble shooting codes
- Swing out control panel for easy access and servicing
- Attractive appliance design for installation in high visibility areas.
- Boiler water supply temperature can be maintained by the Prestige, eliminating the need for a mix system to achieve the desired temperature with high limit protection

Engineering Submittal Data

- ASME Boiler Certification - ASME "H" Stamp
- ENERGY STAR Qualified
- Unit complies with ANSI Z21.13 and CSA 4.9 Boiler Standards
- Fully condensing – 95% AFUE efficiency
- Full modulation capability from 25% to rated input
- Modulation allows fewer and longer cycles leading to lower operating cost and longer component life
- Low pressure drop heat exchanger
- Control interface and logic for indirect hot water storage tank with priority
- Approved for zero clearance to combustibles (excluding vent and boiler piping)
- Automatic boiler freeze protection
- Anti-freeze allowed when used per manufacturer's specifications.
- Superior grade stainless steel heat exchanger construction - 439 Grade
- Self cleaning flue ways in heat exchanger
- Low NOx operation exceeding SCAQMD 2012 regulations

Project / Location: _____ Date: _____

Consulting Engineer / Architect: _____

Mechanical Contractor: _____

Notes: _____

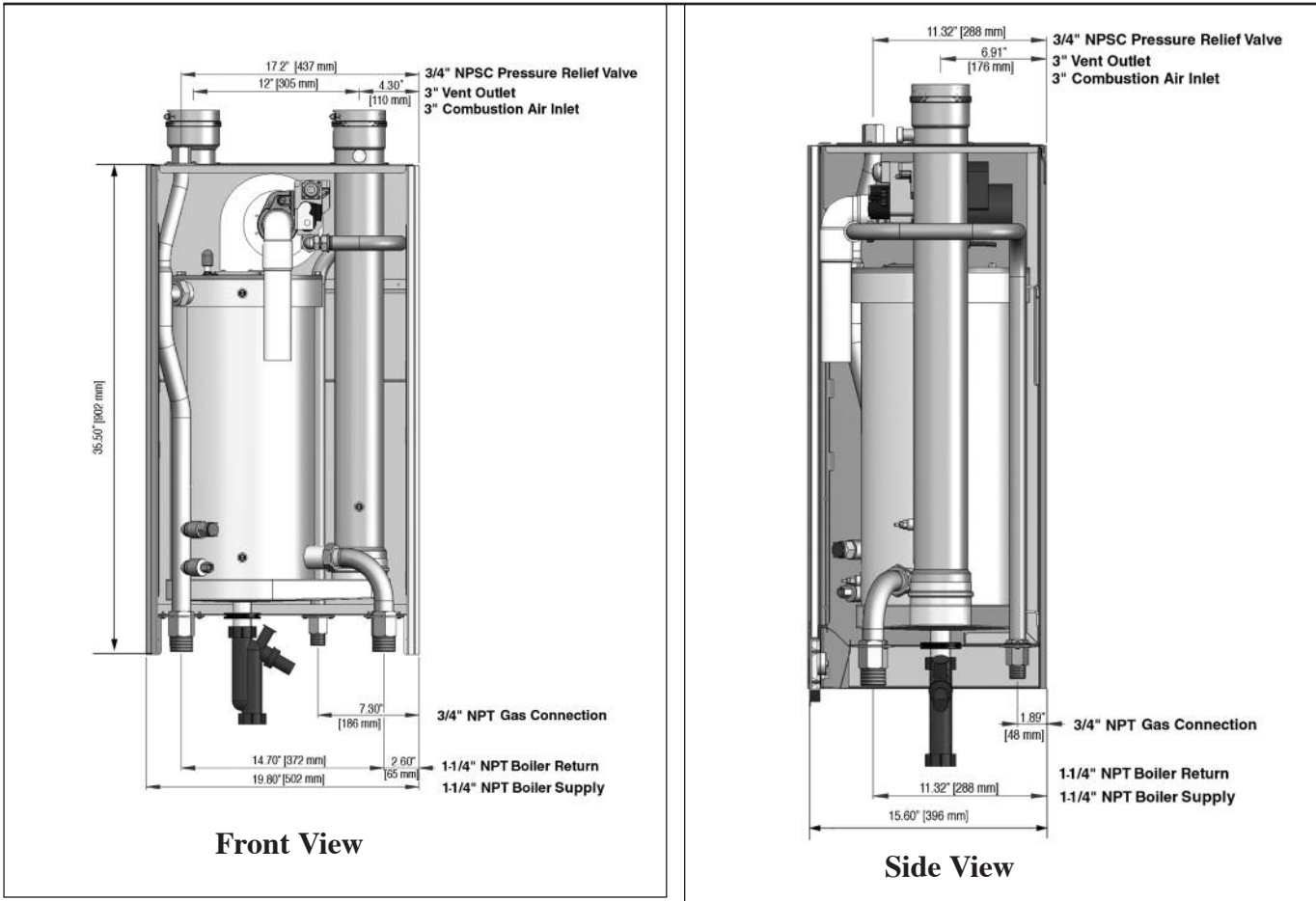

Model	Fuel	Input Modulation MBH	AFUE %	DOE Heating Capacity MBH	NET I=B=R MBH	Water Volume Gal.	Supply/Return Connections	Gas Connection	Vent/Air Diameter	Weight Lbs
Solo 250	Natural or Propane	65 to 245	95	223	194	4.1	1-1/4"	3/4"	3"	142

Pressure Drop Curve with Grundfos Circulators

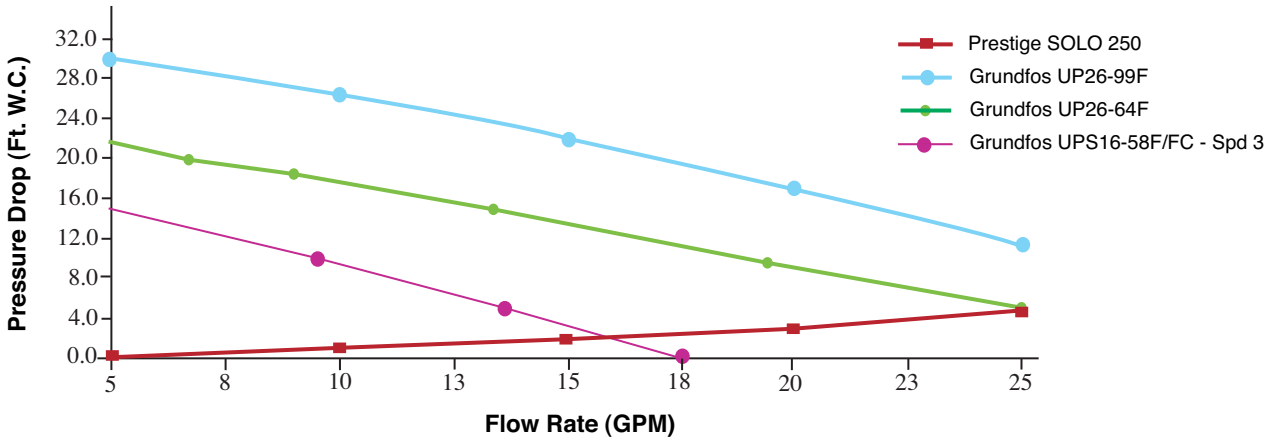

Delta T	GPM	Available System Head in Feet		
		UPS15-58F/FC	UP26-64F	UP26-99F
20	19.4	---	6.9	14.9
30	12.9	4.5	13.5	22.5
40	9.7	8.8	16.5	25.8

Note: Minimum allowable flow rate at full input: 12 gpm Solo 250