

Instinct Burner Head Replacement



Kit Part Number	Description	Model
INSRKIT24	Burner Replacement	Instinct 110
INSRKIT25	Burner Replacement	Instinct 155 & 199 Models

Each Kit Includes:

- Burner Head
- Burner Head Gasket
- Three (3) Burner Screws

Recommended Tools:

- Adjustable Wrenches
- Phillips Head Screwdriver
- Torx Screwdrivers
- 10 mm Socket and/or 10 mm Open Ended Wrench



Indicates a potentially hazardous situation which, if ignored, can result in serious injury or substantial property damage.



Indicates special instructions on installation, operation or maintenance, which are important to equipment but not related to personal injury hazards.



For your safety, turn off electrical power supply at service panel and allow unit to cool before proceeding to avoid possible electrical shock and scald hazard. Failure to do so can cause severe personal injury or death.



Failure to follow instructions below can result in severe personal injury or damage if ignored.

- **Instructions are for a qualified installer/ service technician only.**
- **Read all instructions before proceeding.**
- **Follow instructions in proper order.**

Instinct Burner Head Replacement



1. Preliminary Instructions

1. Verify that the insulation replacement kit is correct for the model of boiler. See table on page 1.
2. Carefully open and unpack the PARTS BOX from its shipping carton.
3. Carefully remove and check for any damage.

NOTICE

Installing damaged insulation/gasket will cause malfunction of the boiler. Contact Triangle Tube right away if the insulation/gasket is damaged in any way.

4. Turn off the electrical power supply to the boiler.
5. Close the manual gas shut off valve to the unit.

2. Removal of the old Burner Head

1. Turn power to the unit "OFF" and allow unit to cool.
2. Shut off gas supply to the inlet of the unit at the main manual shutoff valve to the unit.
3. Remove front jacket panel on the top of the boiler
4. Disconnect all the wires from the gas valve, blower and igniter.

NOTICE

Mark the proper location of all wires before removing them.

5. Remove the air inlet elbow from the venturi. Leave the elbow attached to the air inlet connection at the top of the boiler.
6. Disconnect the gas supply piping to the venturi. Unscrew the nut on either the venturi or the gas valve. Do not discard the gasket as they will be re-used.
7. Unbolt the four bolts securing blower from the burner mounting plate. Do not discard the blower gaskets. Do not discard the bolts as they will be re-used. Remove the blower/venturi/gas pipe assembly from the boiler.

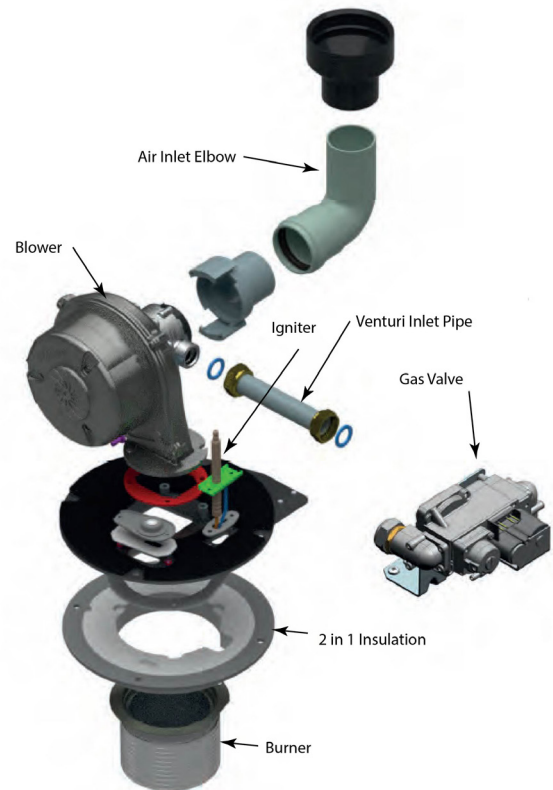

Fig. 1: Instinct 110 Burner Assembly

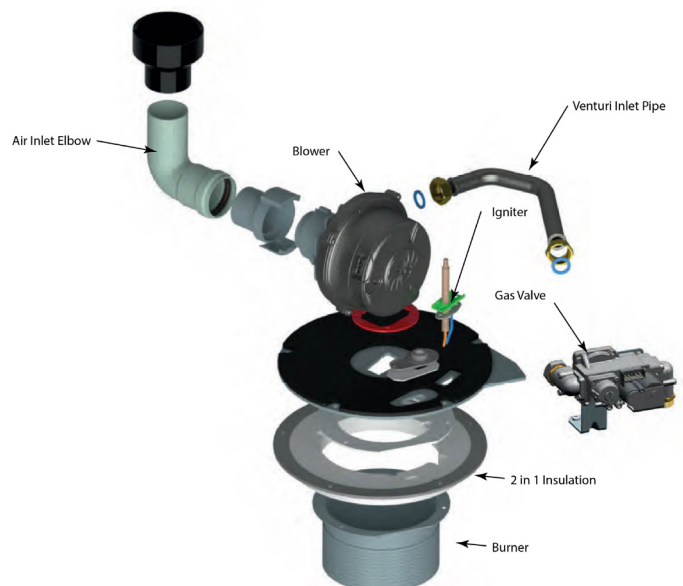

Fig. 2: Instinct 155 Burner Assembly

Instinct Burner Head Replacement

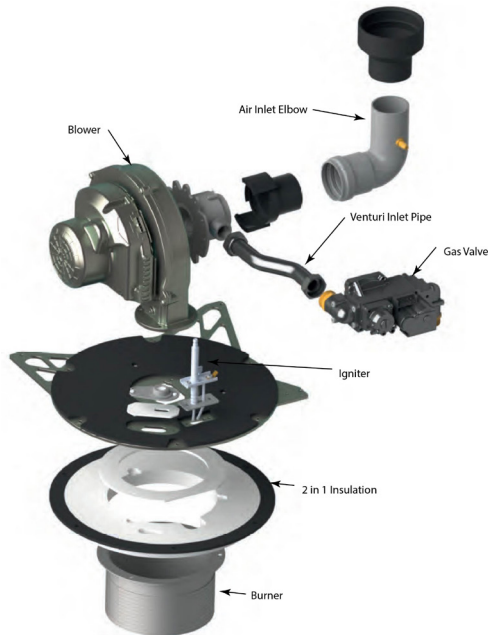

Fig. 3: Instinct 199 Burner Assembly

8. Remove the two screws securing the igniter to the mounting plate. Do not discard the screws or igniter gasket as they will be reused. Remove the igniter out carefully.

NOTICE

Ensure to not damage the igniter. Contact Triangle Tube right away if the igniter is damaged in any way.

9. Remove the nuts securing the burning mounting plate to the rear jacket panel. These screws are for shipping protection and can be discarded.
10. Remove the burner plate mounting nuts. Do not discard the nuts as they will be reused.
11. Remove the burner mounting plate straight up from the heat exchanger body to ensure the insulation is not damaged. Keep the insulation installed in the heat exchanger.
12. Remove the three screws securing the burner head to the bottom of the mounting. Discard the screws and gasket.

3. Installation of the new Burner Head

1. Install the new burner, burner gasket, and screws onto the burner mounting plate. Ensure the flat portion of the burner head is towards the igniter cutout. Tighten the screws to 26.5 to 31 in-lbs of torque.

NOTICE

If the igniter or sightglass cutout are covered in anyway by the burner head, remove and reinstall the burner head so that there is no overlap.

NOTICE

For the reassembly process do not use adhesives on ANY gasket surface.



Ensure the gasket is in place before reassembly. Failure to do so can result in death, serious injury or substantial property damage.

2. Carefully re-insert the burner assembly into the heat exchanger body. Align the burner assembly igniter and sightglass cutout with the combustion chamber insulation igniter and sightglass cutout.

NOTICE

Ensure to not damage the insulation block or burner head during re-installation. Contact Triangle Tube right away if the igniter is damaged in any way.

3. Reinstall the igniter gasket, igniter, and igniter screws. Tighten the screws to 26.5 to 31 in-lbs of torque. Ensure the green grounding cables are connected.

NOTICE

Ensure to not damage the igniter. Contact Triangle Tube right away if the igniter is damaged in any way.

4. Hand tighten the Burner Plate Mounting Nuts to hold the burner assembly in place. Then using a

Instinct Burner Head Replacement



wrench tighten each nut to 44-53 in-lbs.



Do not over tighten. Pinching or tearing of the burner plate gasket may occur causing the possible escape of combustion gases from the combustion chamber resulting in death, serious injury or substantial property damage.

5. Reinstall the blower gaskets onto the burning mounting plate and reattach the blower/venturi/gas line to the burner mounting plate. Tighten the blower bolts to 62-71 in-lbs of torque.



Ensure the gasket is in place before reassembly. Failure to do so can result in death, serious injury or substantial property damage.

6. Re-connect the gas supply piping to the venturi. Ensure the pipe gasket is properly seated before tightening the nut.



Ensure the gasket is in place before reassembly. Failure to do so can result in death, serious injury or substantial property damage.

7. Reattach the air inlet elbow to the venturi.
8. Re-attach all the wires to the gas valve, blower and igniter.
9. Turn on gas supply to the inlet of the unit at the main manual shutoff valve to the unit. Check and test all gas connections for leaks. Repair leaks if found.



Do not check for gas leaks with an open flame. Use a bubble test. Failure to check for gas leaks can cause severe personal injury, death or substantial property damage.

10. Turn power to the unit "ON". The unit is now ready to be placed back into service.