

Instinct Gas Valve Replacement



Kit Part Number	Description	Model
INSRKIT06	Gas Valve Replacement	All Instinct

Each Kit Includes:

- Gas Valve
- Gas Valve O-Rings

Recommended Tools:

- Adjustable Wrenches
- Phillips Head Screwdriver
- Calibrated Combustion Analyzer

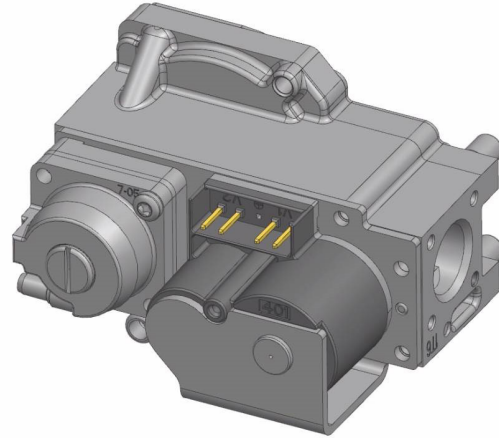

WARNING

Indicates a potentially hazardous situation which, if ignored, can result in serious injury or substantial property damage.

NOTICE

Indicates special instructions on installation, operation or maintenance, which are important to equipment but not related to personal injury hazards.

WARNING

For your safety, turn off electrical power supply at service panel and allow unit to cool before proceeding to avoid possible electrical shock and scald hazard. Failure to do so can cause severe personal injury or death.

WARNING

Failure to follow instructions below can result in severe personal injury or damage if ignored.

- Instructions are for a qualified installer/ service technician only.
- Read all instructions before proceeding.
- Follow instructions in proper order.

Instinct Gas Valve Replacement



1. Preliminary Instructions

1. Verify that the Gas Valve replacement kit is correct for the model of boiler. See table on page 1.
2. Carefully open and unpack the PARTS BOX from its shipping carton.
3. Carefully remove and check for any damage.

NOTICE

Do not proceed with installation and contact Triangle Tube right away if the gas valve is damaged in any way.

4. Turn off the electrical power supply to the boiler.
5. Close the manual gas shut off valve to the unit.

2. Gas Valve Replacement:

1. Turn power to the unit "OFF".
2. Shut off the gas supply to the boiler at the main manual shutoff valve.
3. Remove the front jacket panel.
4. Remove the silicon tube from the gas valve but leave it attached to the air inlet elbow.
5. Remove the Molex plug from the gas valve.
6. Unscrew the 4 screws securing the gas valve fittings on both sides of the gas valve. Do not discard the screws as they will be reused.

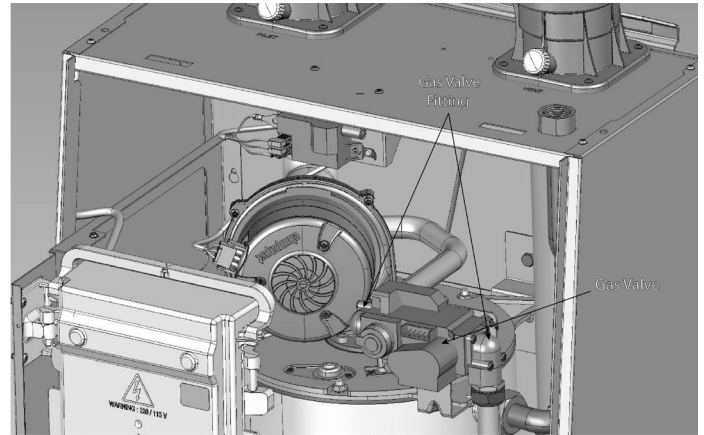

Fig. 2: Instinct 155 Wall Hung Boiler

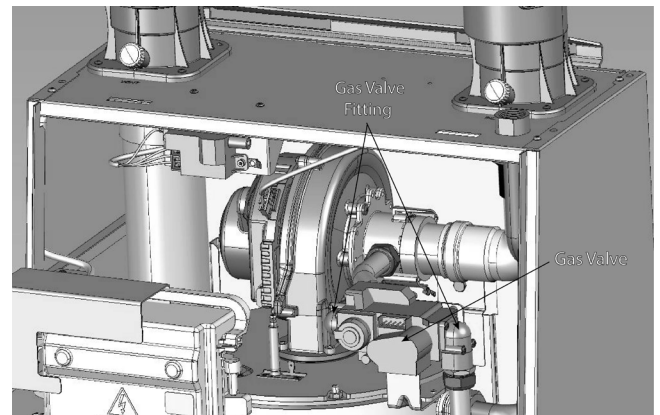

Fig. 3: Instinct 199 Wall Hung Boiler

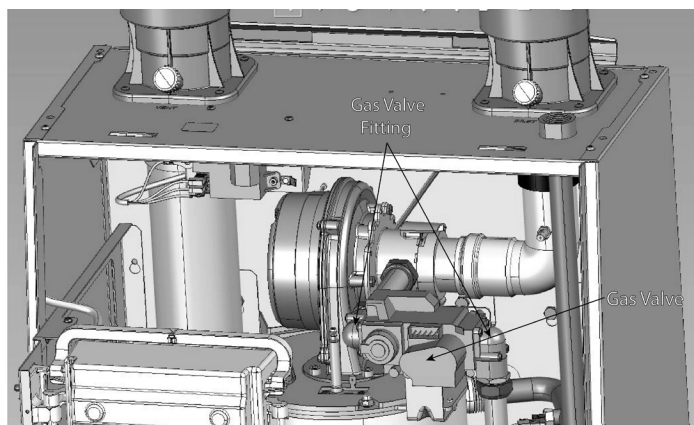

Fig. 1: Instinct 110 Wall Hung Boiler

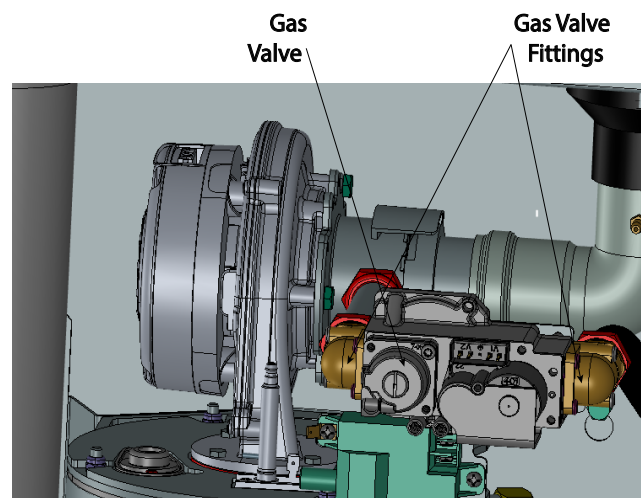

Fig. 4: Instinct 110 Floor Standing Boiler

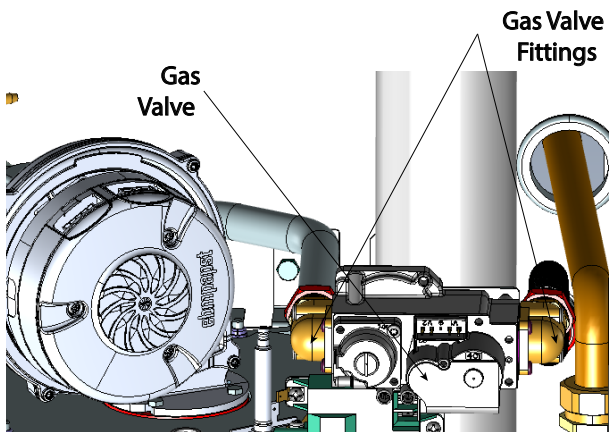

Fig. 5: Instinct 155 Floor Standing Boiler

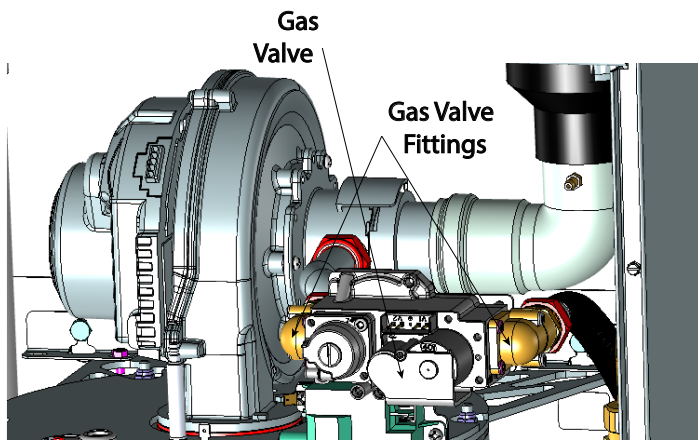

Fig. 6: Instinct 199 Floor Standing Boiler

7. Remove the screws used to mount the gas valve to the bracket. Do not discard these screws as they will be reused
8. Remove the old Gas valve from the boiler.

NOTICE

Ensure the old o-rings installed between the gas valve and fittings are removed and not reused.

NOTICE

For the reassembly process do not use adhesive on any gasket surface.

9. Install new O-Rings in the opening on both sides of the new Gas valve as shown in Fig. 7.



Fig. 7: Gas Valve O-Ring

10. Secure the gas valve to the bracket with the screws previously removed.
11. Secure all four screws on both sides of the gas valve



WARNING

Ensure the O-Rings are properly seated in both gas valve opening prior to tightening the screws. Improperly seated O-rings can cause severe personal injury, death or substantial property damage.

12. Reconnect the Molex plug to the gas valve electrical connection.
13. Check and test all gas connections for leaks. Repair leaks if found.



WARNING

Do not check for gas leaks with an open flame. Use a bubble test. Failure to check for gas leaks can cause severe personal injury, death or substantial property damage.

14. Turn the electrical power "ON" to the boiler to check combustion.

3. Combustion Test and Adjustments

NOTICE

The installer **MUST** perform a complete combustion check to ensure the following combustion levels are met at high and low input firing rates and the burner is operating at optimum conditions.

Instinct Gas Valve Replacement



WARNING

The combustion testing and adjustments must be performed by a qualified installer, service agency or the gas supplier. All combustion measurements must be performed with calibrated equipment to ensure proper readings and accuracy.

WARNING

Failure to perform a complete combustion test at both high and low input rates may result in incomplete combustion and the production of carbon monoxide, which can cause severe personal injury, death or substantial property damage.

1. Touch simultaneously on the up and down soft keys (as high lighted by the wrench icon) for 3 seconds to access the functions for the installer. See Fig. 8.
2. Enter the installer access code "054" by using the LEFT and RIGHT buttons to select a digit and the UP and DOWN buttons to change the digit. Press the center button to enter the access code.



Fig. 8: CTRLMax Navigation Control

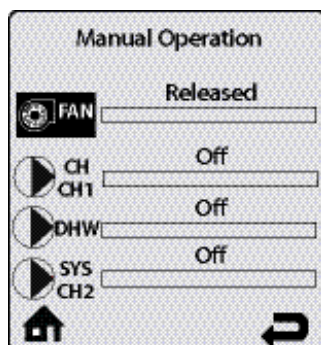

Fig. 9: Controls display

3. Press the RIGHT button to highlight the Manual Operation icon then press the OK button.
4. Press the center button while the FAN icon is highlighted to manually fire the burner and power the CH circulator. See Fig. 9

NOTICE

An adequate CH load must be present to dissipate the heat generated during the combustion test. If an adequate CH load is not available, an indirect water heater can be used to dissipate the heat by creating a DHW call which will enable the DHW circulator.

5. Press the RIGHT button to adjust the firing rate to 100% (high fire). Hold down the RIGHT button to rapidly increase the firing rate.
6. If the combustion levels during high fire are outside the recommended combustion settings, adjust the THROTTLE SCREW using a flat-blade screwdriver as follows:

Counter-clockwise adjustment of the THROTTLE SCREW at High Fire (100% firing rate):

Increase CO2 & Decrease O2

Clockwise adjustment of the THROTTLE SCREW at High Fire (100% firing rate):

Decrease CO2 & Increase O2

7. Once the combustion level is set at high fire, manually place the boiler into low fire mode by pressing the LEFT button to adjust firing rate down to 0% (low fire).
8. If the combustion level (O2 or CO2) during low fire is not within +/-0.2 of the combustion level measured at high fire, shut down the boiler and contact Triangle Tube Tech Support at 856-228-3584, ext. 500
9. Reattach the front jacket panel and return the unit to normal service.

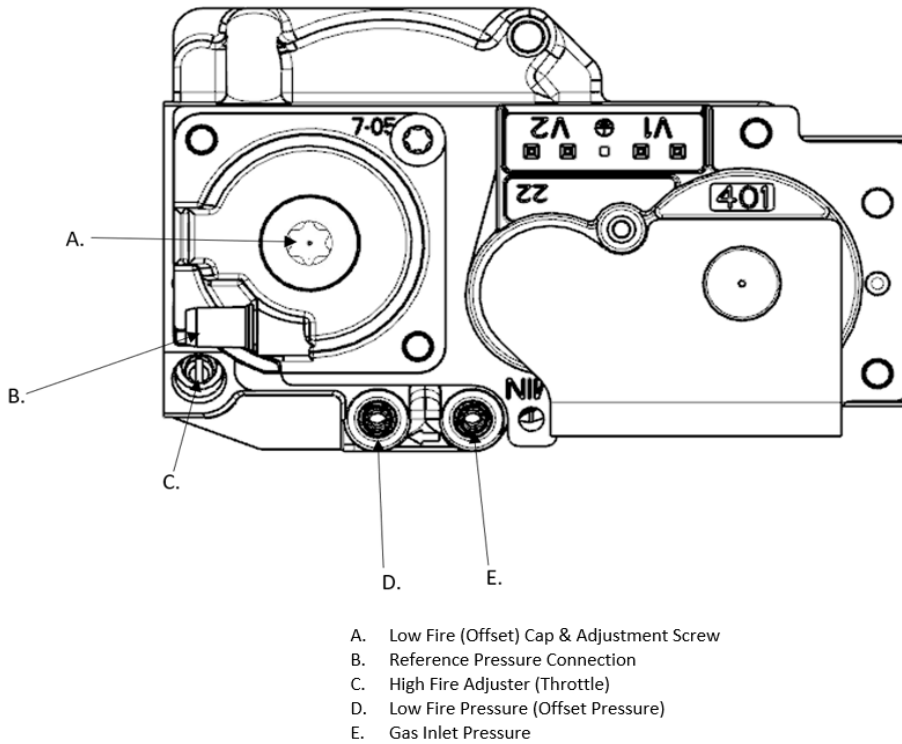

Fig. 10: Throttle Screw Location

		Natural Gas 110, 155	Natural Gas 199	Propane 110, 155	Propane 199
HIGH FIRE	CO2 Range	9.0 to 10.5%	8.5 to 10.5%	10.0 to 11.0%	
	CO2 Target	9.50%		10.80%	
	O2 Range	4.85 to 2.15 %	5.75 to 2.15 %	5.7 to 4.2 %	
	O2 Target	3.95%		4.50%	
	CO Max	<150 ppm @ 9.5% CO2		<200 ppm @ 10.8% CO2	
LOW FIRE	CO2 Range	9.0 to 10.0 %	8.5 to 10.0 %	10.0 to 11.0 %	
	CO2 Target	9.5%	9%	10.8%	10.4%
		Target values are equivalent to High Fire values, ensure CO ₂ values measured are less than or equal to High Fire CO ₂ measurements		Target values are equivalent to High Fire values, ensure CO ₂ values measured are less than or equal to High Fire CO ₂ measurements	
	O2 Range	4.85 to 3.0 %	5.75 to 3.0 %	5.7 to 4.2 %	
	O2 Target	3.95%	4.85%	4.5%	5.1%
		Target values are equivalent to High Fire values, ensure O ₂ values measured are higher than or equal to High Fire O ₂ measurements		Target values are equivalent to High Fire values, ensure O ₂ values measured are higher than or equal to High Fire O ₂ measurements	
	CO Max	10 ppm		10 ppm	

Table 1: Recommended Combustion Settings