

ENGINEERING BULLETIN

Subject: Gas Valve Adjustment Instructions
for Natural Gas and Propane

Date: 12/6/2021 EB073

The following instructions address the adjustment of the appliance gas valve for Natural Gas and Propane. Be sure to review and comply with all SAFETY WARNING labels as noted below.



- Instructions are intended for a qualified installer or service technician only.
- Read all instructions before proceeding.
- Follow instructions in proper order.



If an analyzer is not available, DO NOT make any adjustment to the gas valve. Recommended Tools:

- Flat Head Screwdriver
- T40 Torques key
- Calibrated Combustion Analyzer



DEFINITIONS

The following terms are used throughout this manual to bring attention to the presence of potential hazards or to important information concerning the product.



Indicates the presence of a hazardous situation which, if ignored, will result in substantial property damage, serious injury, or death.



Indicates a potentially hazardous situation which, if ignored, can result in substantial property damage, serious injury, or death.



Indicates a potentially hazardous situation which, if ignored, can result in minor property damage, or injury.

NOTICE

Indicates special instructions on installation, operation or maintenance, which are important to the equipment but not related to personal injury hazards.

BEST PRACTICE

Indicates recommendations made by Triangle Tube for the installers, which will help to ensure optimum operation and longevity of the equipment.



Carbon Monoxide gas can cause serious injury or death. Obey all PPE requirements at all times, and if evacuation is required, vacate immediately

Triangle Tube accepts no liability for any damage, injury, or loss of life resulting from incorrect installation, alteration of any factory supplied parts, or the use of parts or fittings not specified by Triangle Tube. If there is a conflict or doubt about the proper installation of the unit or any factory supplied replacement parts please contact Triangle Tube Technical Support.

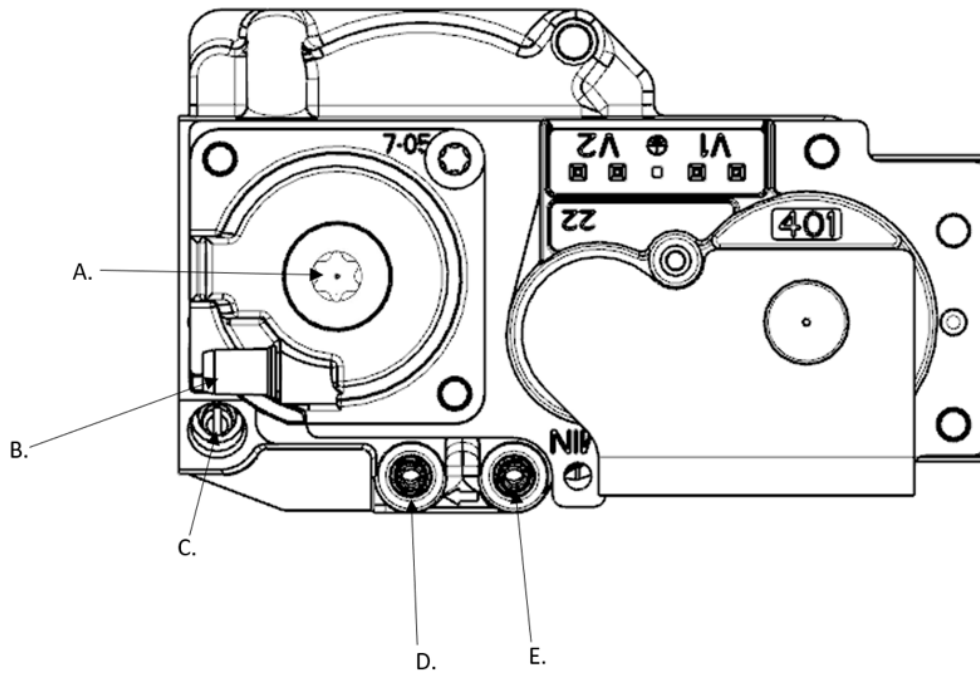

- A. Low Fire (Offset) Cap & Adjustment Screw
- B. Reference Pressure Connection
- C. High Fire Adjuster (Throttle)
- D. Low Fire Pressure (Offset Pressure)
- E. Gas Inlet Pressure

Diagram 1 - Gas Valve Diagram

		Natural Gas 110, 155	Natural Gas 199	Propane 110, 155	Propane 199
HIGH FIRE	CO ₂ Range	9.0 to 10.5%	8.5 to 10.5%	10.0 to 11.0%	
	CO ₂ Target	9.50%		10.80%	
	O ₂ Range	4.85 to 2.15 %	5.75 to 2.15 %	5.7 to 4.2 %	
	O ₂ Target	3.95%		4.50%	
	CO Max	<150 ppm @ 9.5% CO ₂		<200 ppm @ 10.8% CO ₂	
LOW FIRE	CO ₂ Range	9.0 to 10.0 %	8.5 to 10.0 %	10.0 to 11.0 %	
	CO ₂ Target	9.5%	9%	10.8%	10.4%
		Target values are equivalent to High Fire values, ensure CO ₂ values measured are less than or equal to High Fire CO ₂ measurements		Target values are equivalent to High Fire values, ensure CO ₂ values measured are less than or equal to High Fire CO ₂ measurements	
	O ₂ Range	4.85 to 3.0 %	5.75 to 3.0 %	5.7 to 4.2 %	
	O ₂ Target	3.95%	4.85%	4.5%	5.1%
		Target values are equivalent to High Fire values, ensure O ₂ values measured are higher than or equal to High Fire O ₂ measurements		Target values are equivalent to High Fire values, ensure O ₂ values measured are higher than or equal to High Fire O ₂ measurements	
	CO Max	10 ppm		10 ppm	

Table 1 – Combustion Tolerance

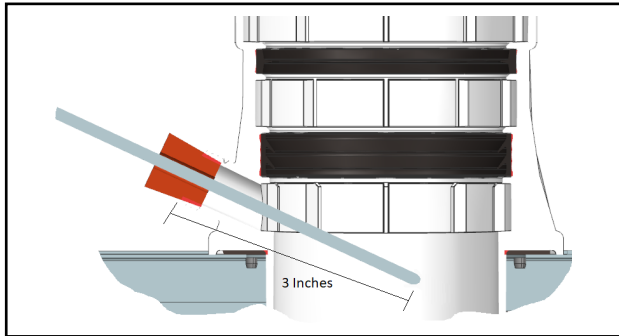

Fig. 1

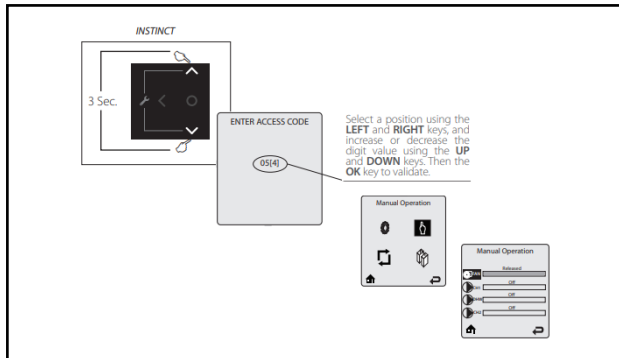

Fig. 2

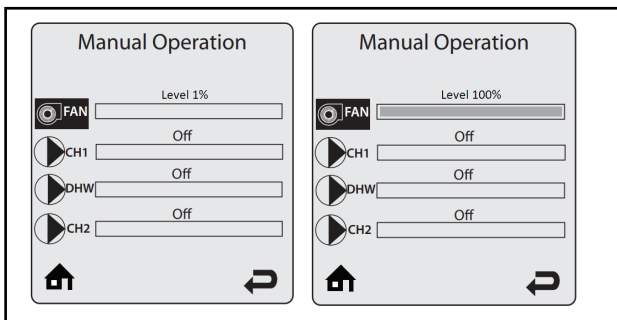

Fig. 3

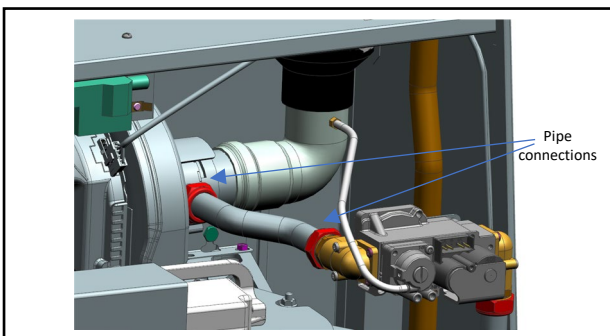

Fig. 4

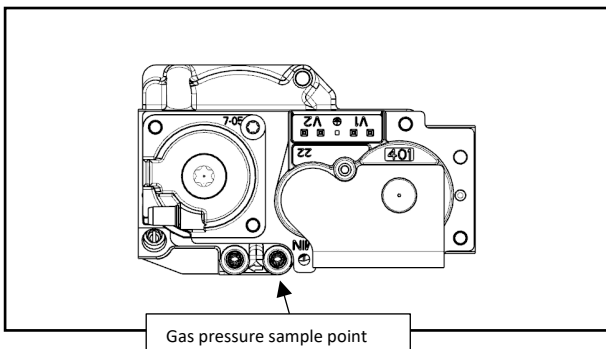















Fig. 5

1. Preliminary Checks

- Sample probe must be inserted sufficiently, and ensure sampling is correct when CO₂/O₂ readings are measured (refer to Fig.1 for probe position and insertion).
- Appliance must be operating in service mode at 100% for high fire and 1% for low fire when CO₂/O₂ values are measured (Fig.2 / 3). Heating circuit should have all circulation pumps operating, providing sufficient flow through the appliance.
 - Touch simultaneously on the  and  soft keys for 3 seconds to access the functions for the installer. Reference
 - Enter the installer access code "054" by using the  and  soft keys to select a digit location and the  and  soft keys to change the digit. Touch the  soft key to enter the access code.
 - Touch the  soft key to highlight the Manual Operation icon  then touch the  soft key.
 - Touch the  soft key while the FAN icon is highlighted to manually fire the burner and power the CH circulator(s).
 - Touch the  soft key to adjust the firing rate from 1% to 100%. Hold down the  soft key to rapidly increase the firing rate.

Once the combustion level is set at high fire (100%), manually place the boiler into low fire (1%) mode by touching the  soft key to adjust firing rate down.

- Ensure appliance gas valve reference tube is correctly installed and connected with no kinks or splits (Fig.4).
- Replace fiber washers with the new ones provided (hardware box) (Fig.4).
- Ensure gas pipe connections are tight and leak free. See Section 10.5 on page 62 from installation guide.
- Check the incoming gas pressure at the unit (fig.5) is in accordance with table 2 with all gas appliances in operation and standby.

	Minimum	Maximum
Natural Gas	5 in w.c.	13 in w.c.
Propane (LP)	8 in w.c.	12 in w.c.

Table 2 – Gas Pressure (inches water column)

- If CO₂ is below specified tolerance (as per table 1) record High fire CO₂/O₂ in Table 4 – Section 1A & 1B, then follow section 2 and 3 to adjust High and Low fire Combustion.

Triangle Instinct Solo/Combi Gas Valve Adjustment Instructions

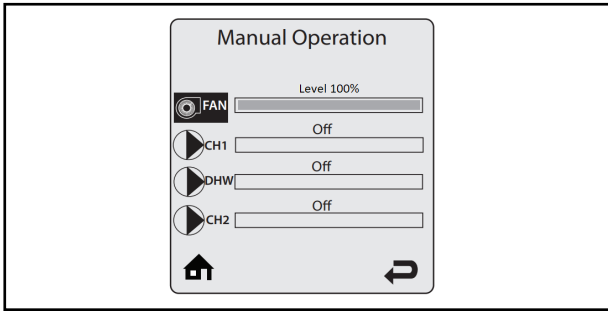

Fig .6

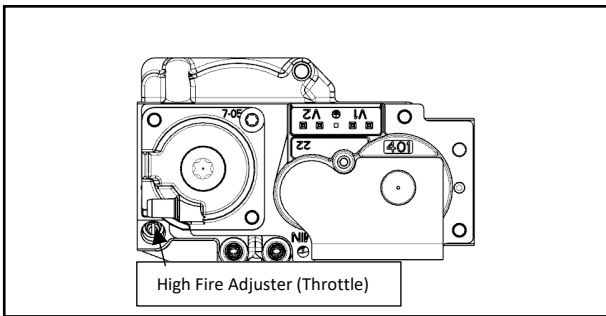

Fig .7

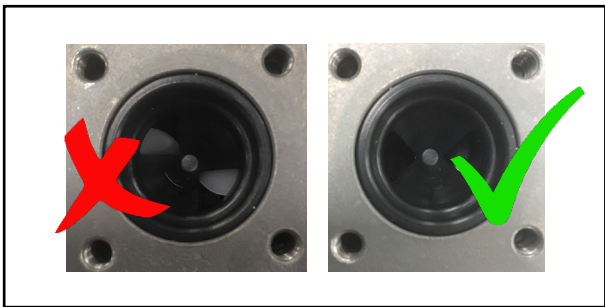

Fig .8

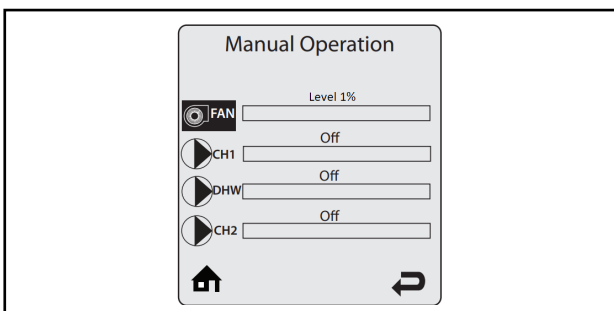

Fig .9

2. High Fire Adjustment (Throttle)

- Operate boiler to High Fire 100% in service mode (Fig.6).
- Alter High Fire adjuster (throttle) (fig.7) in $\frac{1}{4}$ incremental steps until CO₂ is within specified tolerance (as per table 3).
- Wait for stable combustion reading between each adjustment.

NOTICE



Direction		INSTINCT Solo/Combi
Clockwise		Decrease CO ₂ / Increase O ₂
Counter-Clockwise		Increase CO ₂ / Decrease O ₂

Table 3 – High Fire Adjuster (Throttle)

- If CO₂ levels have reached the limit or high fire adjustment screw (throttle) is fully open*, record High fire CO₂/O₂ in Table 4 – Section 2A).

*if no stop can be felt remove gas valve and ensure butterfly valve is open all the way (no white seen) (fig.8).

- Operate appliance to Low fire 1% (fig.9).
- If CO₂ at low fire is below specified tolerance (as per table 1) move to section 3. Low Fire Adjustment.
- If combustion is within tolerance (as per Table 1) Record Low Fire CO₂/O₂ in Table 4 – Section 2B and do not adjust low fire Adjuster (offset).

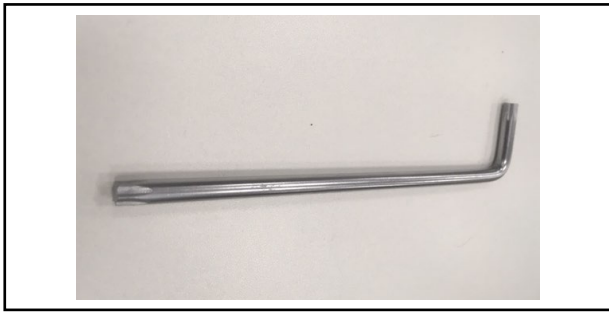

Fig .10

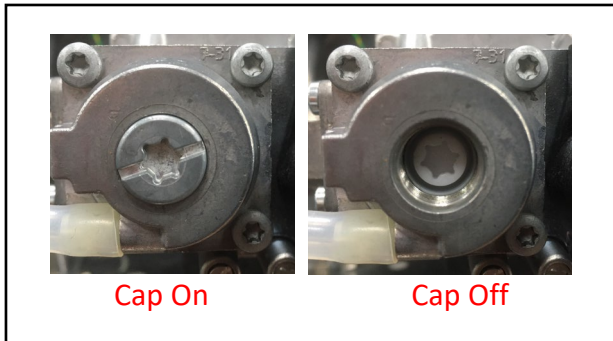

Fig .11

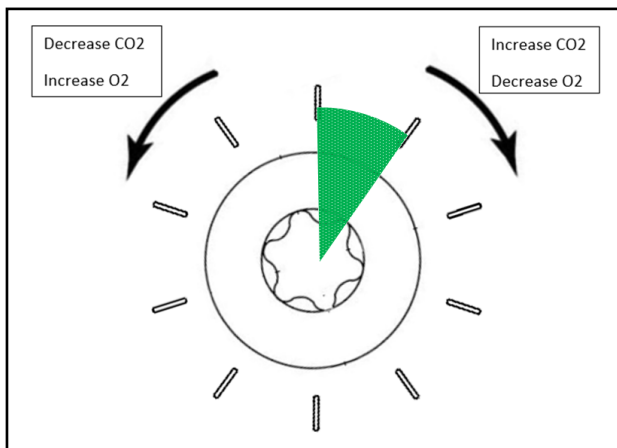

Fig.12

WARNING

Valve responds slowly so make small 1/10th adjustment to the low fire adjustment screw (offset) and wait for stable combustion reading before repeating.

3. Low Fire Adjustment (Offset)

- Operate appliance at low fire 1% in service mode (Fig.9).
- Ensure the boiler is at low fire under a stable operating condition whilst monitoring CO₂/O₂ values.
- If low fire CO₂/O₂ values are still below tolerance, record Low Fire CO₂/O₂ in Table 4 – Section 2B



Direction		INSTINCT Solo/Combi
Clockwise		Increase CO ₂ / Decrease O ₂
Counter-Clockwise		Decrease CO ₂ / Increase O ₂

Table 4 – Low Fire Adjuster (Offset)

Using “T40” torques key/bit (fig 10), unscrew, and remove cap of the gas valve low fire adjustment (offset) (Fig.11).

- Adjust low fire screw (offset) clockwise in small 1/10th of a turn adjustments until the CO₂ measurement is within the tolerance band but no greater than 1% CO₂ increase than the combustion reading after throttle adjustment at low fire (Fig.12). Refer to result recorded in Table 4 – Section 2B.

NOTICE

1% CO₂ = 1.8% less O₂ on Natural Gas
1% CO₂ = 1.5% less O₂ on Propane

WARNING

CO₂ measurement should be increased no greater than 1% via low fire adjustment screw (offset) adjustment from previous reading at low fire Refer to result recorded in Table 2 – Combustion Results summary (column 2-Low fire.)

- Record Low Fire CO₂/O₂ in Table 3 – section 3.B.
- If minimum CO₂/O₂ is still below allowed specification tolerance contact triangle tube technical support. Tel: (856) 228 8881
- Operate appliance to High Fire 100% (Fig.6) Record High Fire CO₂/O₂ in Table 3 – 3.A).
- Table 2 – Combustion Results summary should be submitted to Triangle Tube technical support



Instinct model Number: _____

Serial Number: _____

Date of Installation: _____

Fuel: Natural gas Propane

	1.Combustion Readings Before Adjustment	2.Combustion Readings After high fire Adjustment	3.Combustion Readings After Low Fire Adjustment
1.A High fire	CO ₂ _____ O ₂ _____ CO _____	2.A High fire	CO ₂ _____ O ₂ _____ CO _____
		3.A High fire	CO ₂ _____ O ₂ _____ CO _____



CO₂ measurement should be increased no greater than 1% via offset adjustment from previous reading at low fire (column 2. After Throttle Adjustment)

1.B Low fire	CO ₂ _____ O ₂ _____ CO _____	2.B Low fire	CO ₂ _____ O ₂ _____ CO _____	3.B Low fire	CO ₂ _____ O ₂ _____ CO _____
--------------	---	--------------	---	--------------	---

→ 1% max Increase

Worked Example on Propane (LP)

Low fire	CO ₂	9	→ 1% max Increase	CO ₂	10
	O ₂	7.2		O ₂	5.7
	CO	4		CO	6

NOTICE

1% CO₂ = 1.8% less O₂ on Natural Gas
1% CO₂ = 1.5% less O₂ on Propane

Table 4 – Combustion Results summary

QR codes to refer to Videos of combustion analyzer / gas valve adjustment / sensing lines + connections



Triangle Tube - 1240 Forest Parkway, Suite 100, West Deptford NJ 08066
Tel: (856) 228 8881 - Fax: (856) 228 3584 - E-mail: info@triangletube.com

Combustion Adjustment Instruction – Flow chart

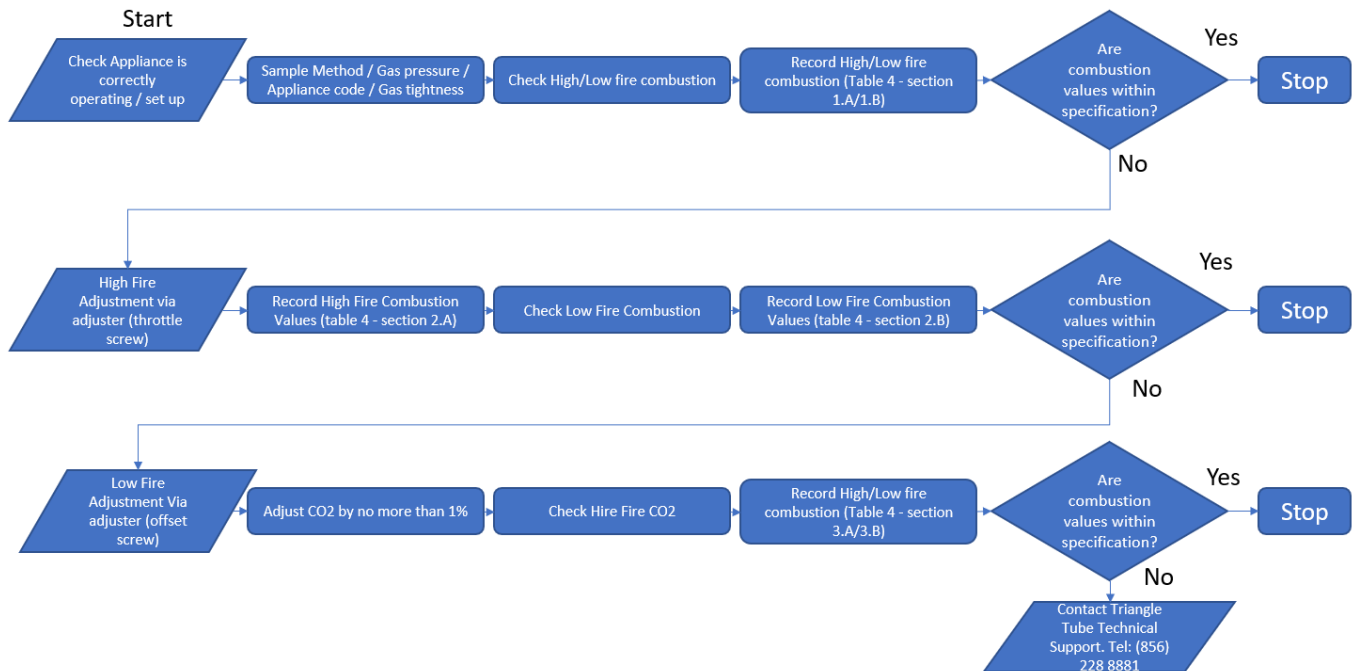

Please contact technical support at techsupport@triangletube.com (856) 228-8881 x575 with any questions.