

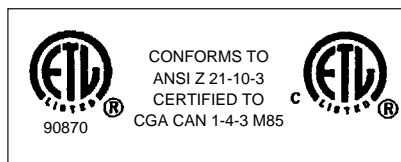

Phase III HM Series G-25 & G-30 Gas Fired Forced Draft with Optional Sealed Combustion Combination Heaters



- Input from 100,000 to 120,000 Btu/hr -

* INSTALLATION AND MAINTENANCE * M A N U A L

NOTICE

Warranty Registration Card must be filled out by the customer and mailed within thirty (30) days of installation in order to gain warranty coverage.

When receiving Phase III[®] units, any claims for damage or shortage in shipment must be filed immediately against the transportation company by the consignee.

WARNING

If the information in this manual is not followed exactly, a fire or explosion may result causing property damage, personal injury or death.

For Your Safety

- Do not store or use gasoline or other flammable vapors and liquids in the vicinity of this or any other appliance.
- WHAT TO DO IF YOU SMELL GAS
 - Do not try to light any appliance
 - Do not touch any electrical switch; do not use any phone in your building.
 - Immediately call your gas supplier from a neighbor's phone. Follow the gas supplier's instructions.
 - If you cannot reach your gas supplier, call the fire department.

Installation and service must be performed by a qualified installer, service agency or the gas supplier.

TABLE OF CONTENTS

SAFETY INFORMATION

Product and safety information	1-2
--	-----

PRE-INSTALLATION

Code compliance	3
Verifying venting system	3
Installation located in confined spaces	4
Combustion and ventilation air requirements	4
Recommended clearances	4
Locating combination heater	5
Operating restrictions	5

INSTALLATION

Venting the combination heater	6
Chimney draft venting	6
Direct venting	6
Venting through cold area	6
Direct venting procedures	7
Piping the combination heater	9
Thermal expansion	9
Air vent	9
Temperature and pressure relief valve	9
Pressure relief valve	9
Water hammer	9
General piping	10
Inner tank (domestic) piping	10
Outer tank (system) piping	10
Domestic piping diagram	11
Primary piping - near appliance piping	12
Space heating piping diagram	13
Combination heater wiring	14
Wiring diagram	14-17
Gas supply piping	18-19

COMBINATION HEATER START-UP

Filling the inner tank	20
Filling the outer tank	20
Burner operation	21
System piping	21

TABLE OF CONTENTS

Venting system	21
Operating instructions	22

SETTING THE WATER TEMPERATURE

Setting the combination water heater limits	23
Setting domestic water temperature	23

COMBINATION HEATER MAINTENANCE

Annual maintenance	24
Flueway	24
Pressure relief valve and T&P relief valve	24
Antifreeze	24
Air vent	25
Periodical maintenance	25
Combustion chamber	25
Draining the combination heater	25
Drain outer tank	25
Drain inner tank	25-26
Space heating system contains sufficient anti-freeze	28

SPECIFICATION DATA

Dimensional drawing	27
Dimensional data	28
Performance	28

PARTS LIST

Parts List	29
----------------------	----

SAMPLE SPECIFICATION

Sample specification	30
--------------------------------	----

PRODUCT & SAFETY INFORMATION

The following terms are used throughout this manual to bring attention to the presence of potential hazards or to important information concerning the product.

DANGER

Indicates the presence of a hazardous situation which, if ignored, will result in death, serious injury or substantial property damage.

WARNING

Indicates a potentially hazardous situation which, if ignored, can result in death, serious injury or substantial property damage.

CAUTION

Indicates a potentially hazardous situation which, if ignored, may result in minor injury or property damage.

NOTICE

Indicates special instructions on installation, operation or maintenance, which are important to equipment but not related to personal injury hazards.

DANGER

Do not use this appliance if any part has been under water. Immediately call a qualified service technician to inspect the appliance and to replace any part of the control system which has been under water.

DANGER

WHAT TO DO IF YOU SMELL GAS

- Do not try to light any appliance
- Do not touch any electrical switch; do not use any phone in your building.
- Immediately call your gas supplier from a neighbor's phone. Follow the gas supplier's instructions.
- If you cannot reach your gas supplier, call the fire department.

Installation and service must be performed by a qualified installer, service agency or the gas supplier.

WARNING

Should overheating occur or the gas supply fails to shut off, turn OFF the manual gas control valve external to the appliance.

CAUTION

To prevent damage to inner tank, installer must:

- Fill inner tank prior to outer tank during start-up.
- Relieve primary system pressure below 15 psig prior to draining inner tank.

WARNING

Bacteria can develop in the domestic water system if certain minimum water temperatures are not maintained.

DANGER

Water temperature over 125°F can cause severe burns instantly or death from scalds.

- Children, disabled and elderly are at highest risk of being scalded.
 - Never leave them unattended in or near shower, bathtub or sink.
 - Never allow small children to use a hot water faucet or draw their own bath.
- If any one using hot water in the building fits this description or codes require specific water temperatures at hot water faucet, we recommend:
 - a) ensure the factory installed thermostatic mixing valve is working properly.
 - b) to set the thermostatic mixing valve for the lowest temperature which satisfies your hot water need.

This will also provide the lowest operating cost.

WARNING

Adjusting the water temperature

Setting the knob to a lower temperature will not have an immediate effect. The stored hot water will first have to be used.

Further adjustments may be necessary as you use your Phase III Combination Heater System.

CAUTION

Protection must be taken against excessive temperature and pressure!

TO PROTECT AGAINST EXCESSIVE TEMPERATURE AND PRESSURE

- Check if the Temperature and Pressure (T&P) relief valve is in the location provided. (Domestic Water)
- Check if the 30 psi relief valve supplied is in the location provided. (Primary water)
- To avoid injury, install the relief devices to comply with local code requirements.

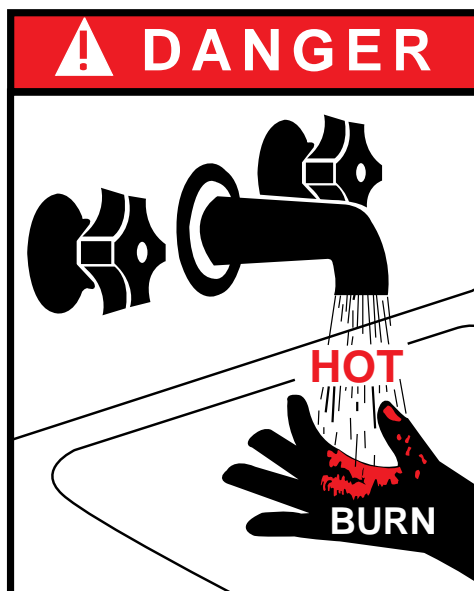

1- CODE COMPLIANCE

Combination Heater installation must conform to the requirements of local codes and the authority having jurisdiction. In the absence of these requirements:

Gas fired heaters should be installed in accordance with National Fuel Gas Code, ANSI Z223.1.

For installations in Canada - CGA/B149 Installation Code for Gas Burning Equipment.

All electrical wiring, including grounding of the heater must be in accordance with local codes; or in the absence of local codes with the National Electrical Code, ANSI/NFPA 70.

The HM G-Series combination heaters are exempted from ASME Section VIII-1-86-136. Check with local codes for applicability.

2- VERIFYING VENTING SYSTEM

- Confirm that the venting system is of sufficient size to handle the flue gases of all connected equipment.
- Check that it is clear and free of obstructions. Particular attention should be given to replacement of oil systems.
- Soot may have degraded the chimney liner and/or accumulated in the chimney liner requiring a liner replacement or cleaning.
- Visually inspect the venting system for proper size and horizontal pitch.

DANGER

If inspection reveals that the existing chimney is unsafe or inadequate for the application, it should be rebuilt to conform to local or national codes, lined or relined, or provided with a new chimney or vent sized for the application.

Anatomy of your Combination Heater

Legend

- A. Combustion air inlet
- B. Flueway fitted with stainless steel turbulators
- C. Primary water
- D. Primary Circuit thermostat (up to 180°F) sensing bulb
- E. Burner
- F. Water cooled immersed combustion chamber
- G. Primary circuit drain connection
- H. Corrugated stainless steel heat exchanger
- J. 1 1/2" of rigid (CFC-Free) polyurethane insulation
- K. Steel body containing primary water
- L. Primary Connections
- M. Baffles (turbulators)
- N. Primary connection
- O. Baked enamel steel jacket
- T. Domestic water
- U. Safety limit thermostat (200°F) (manual reset) (not shown)
- L.W.C.O.: Low water cut-off device (not shown)

Fig. 1: Cross section of Combination Heater

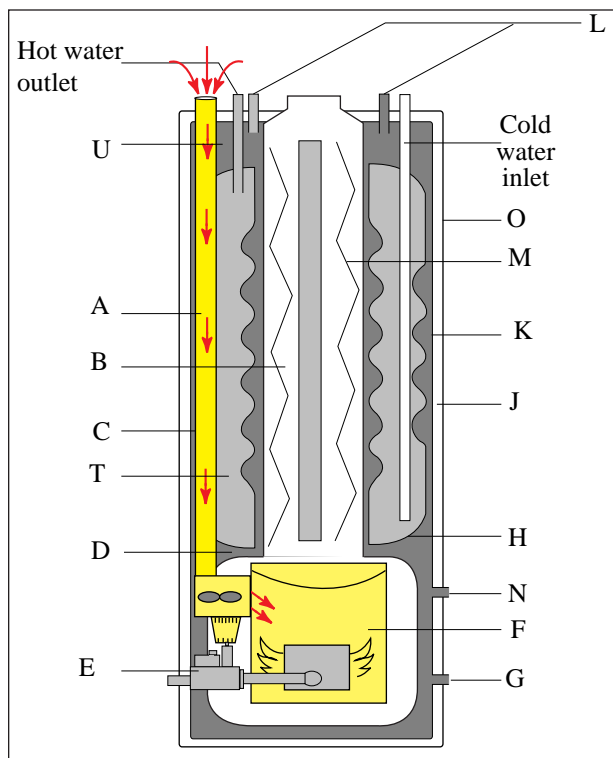

3- INSTALLATION LOCATED IN CONFINED SPACES

Sufficient air must be provided for satisfactory combustion, proper venting and ventilation to maintain ambient temperatures at safe limits under normal operating conditions in accordance with National Fuel Gas Code latest editions.

For installations located in unconfined spaces in buildings, infiltration may be adequate for combustion and ventilation. However, in a building of tight construction (i.e. weather stripping, vapor barriers, caulked, etc.), additional air may be provided using the methods described in Combustion and Ventilation Air Requirements.

4- COMBUSTION AND VENTILATION AIR REQUIREMENTS

1. When all air is to be taken from INSIDE a building with adequate infiltration, the confined space shall be provided with two permanent openings to the room. Each opening, one located within 12" above the floor the other within 12" of the ceiling, shall have a free area of one square inch per 1,000 BTU/H for the total input of all the equipment located in the space, but not less than 100 square inches.
2. When all air is taken from OUTDOORS the confined space shall be provided with two openings, one 12" above the floor the other 12" below the ceiling. Each opening shall be sized for total input of all the equipment in the space as follows:
 - a. If opening is directly connected to the outdoors, or if connected to the outdoors through vertical ducts: 1 square inch free area per 4,000 BTU/H total input.
 - b. If opening is connected to the outdoors through horizontal ducts: 1 square inch free area per 2,000 BTU/H total input.
3. Ducts, when used, shall have the same cross sectional area as the free area of the openings to which they are connected.

The minimum dimension of a rectangular air duct is 3 inches.

4. Sealed combustion applications:

- A 3" diameter vent can be connected directly to the blower inlet to draw outside air directly to the heater.
- See Table 1, pg. 7 for Air Inlet System Limitation.
- Galvanized steel, stainless steel or equivalent vent material.

NOTICE

When the combination heater is to be installed in beauty shops, dry cleaning establishments or other places with airborne chlorides, fluorides, hydrocarbons or cleaning fluids, it is essential the combustion air is taken from outside these areas.

5- RECOMMENDED CLEARANCES

- Clearance to combustibles:
Sides 6", Top 6", Venting 8", Rear 6", Front 6" .

NOTICE

HM combination heaters are certified for combustible floors. This combination heater should not be installed directly on carpet. It must be installed directly on the floor or on metal or wood panel covering the entire combination heater base. The panel must be strong enough to carry the weight of the heater when full of water.

- Clearance for servicing:
 - 12" for piping & servicing rear.
 - 24" for access to control and components, front.
 - 36" for flueways, top.
 - 6" on remaining side

6- LOCATING COMBINATION HEATER

- Direct, sidewall venting

WARNING

Give special attention to location of combination heater vent to avoid possibility of severe personal injury, death, or substantial property damage.

- Flue gases will form a white plume in winter.
- Plume could obstruct favorite window view.
- Prevailing winds could cause freezing of condensate and water/ice build-up on building, plants or roof.
- Excessive winds may cause nuisance Combination Heater shutdowns when unit is sidewall vented.
- Locate or guard the vent to prevent accidental contact by people or pets.
- Vent must terminate at least 4 feet below, 4 feet horizontally from any door, window or gravity air inlet to the building. This vent must not be less than 7 feet above grade when located adjacent to public walkways.
- DO NOT terminate vent into window well, stairwell, alcove, courtyard or other recessed area.
- DO NOT terminate vent above any door, window or gravity air inlet. Condensate can freeze causing ice formations.
- Terminate vent at least 6 feet from adjacent walls.
- Terminate vent at least 1 foot above grade, including normal snowline.

NOTICE

This combination heater is not approved for outdoors installation. It should be located indoors in an area with above freezing temperatures.

- The combination heater should be located so that any leakage from the tank or water connections will not cause damage to the area adjoining the combination heater or to lower floors in the structure.
 - When such a location is unavoidable a suitable drain pan with adequate drainage, should be placed under the combination heater. The pan must not restrict combustion air flow.

7- OPERATING RESTRICTIONS

- Maximum working pressure for inner (domestic water) tank is 150 psig.
- Maximum working pressure for outer (primary water) tank is 45 psig.
- Maximum domestic hot water temperature is 180°F (use only for special high-temperature operational requirements).
- Inner tank has factory installed Temperature & Pressure Relief Valve with an AGA rating of 100,000 Btu/hr for G-25 and 200,000 Btu/hr. for G-30.
- Outer tank has a factory installed 30 psig relief valve rated at 535,000 Btu/hr
- Electrical rating: 120 V, 60 Hz, less than 12 amperes
- Single wall heat exchanger in combination heater complies with National Standard Plumbing Code, provided that:
 - Outer tank water (including additives) is practically non-toxic, having toxicity rating or class of 1, as listed in Clinical Toxicology of Commercial Products,
 - Outer tank pressure is limited to maximum 30 psig by approved relief valve.
- pH & chloride limits for combination heater are:
 - Chloride, less than 80 mg/l.
 - pH, 6-8.

1- VENTING THE COMBINATION HEATER

- Determine venting method to use. Refer to appropriate sections for installation details.
- Use vent materials approved by local codes for gas-fired appliances. In their absence refer to:
 - National Fuel Gas Code, ANSI Z223.1.
 - In Canada, refer to CAN/CGA B149 Installation Code for Gas Fired Equipment.
 - NFPA 211, Standard for Chimneys, Fireplaces, Vents and Solid Fuel Burning Appliances.

1A. Chimney Draft Venting

- Use galvanized steel vent or equivalent
- To prevent downdrafts, chimney should extend at least 2 feet above highest part of roof or other structures within 30 feet.
- To vent with another appliance, see National Fuel Gas Code, ANSI Z223.1, latest edition.
- For inside chimney (no walls exposed to outside).
 - Inside of chimney must be lined with vitreous tile or metal liner.
 - Maintain two-inch clearance from combustible material to vent pipe.
 - DO NOT use chimney with open fireplace.
 - Inspect chimney and clean if needed.
 - Make horizontal runs as short as possible. Long runs can cause condensation.
 - When longer runs are used, support with appropriate hangers.
 - To prevent blockage, do not vent into bottom of chimney.
 - Vent pipe must not go beyond inside wall of chimney.

- Vent passing through floors or ceilings must be firestopped.

- Outside chimney (one or more walls exposed to outside)
 - Can be used for chimney draft venting only when lined with corrosion resistant metal liner. Provide condensation drain.
 - Size liner per ANSI Z223.1. Increase breeching at the appliance.
 - Can be used a raceway for direct venting.

1B. Direct Venting**CAUTION**

When replacing an existing appliance on common venting system, the vent system may be too large for remaining appliances. Refer to ANSI Z223.1 for proper sizing.

WARNING

Give special attention to location of Combination Heater vent to avoid possibility of severe personal injury, death, or substantial property damage.

- Review “Locating Combination Heater” to determine location of venting.
- Use AL29-4C or equivalent vent material.

1C. Venting Through Cold Areas

- Extended runs through cold areas could cause condensation which must be drained away.
- Provide a means to trap and drain condensation from the vent system. Do not place drain where freezing could occur.
- Crimped ends of vent pipe must face toward appliance.

- Use AL29-4C or equivalent vent material and follow “Direct Venting” Procedure.

1D. Direct Venting Procedure

1. Determine entire vent length and number of elbows required. Actual venting system must not exceed limitations in Table 1 below or as stated in ANSI Z 223.1.
2. Use 3-inch diameter vent pipe pitched up from Combination Heater. Do not connect other appliances to this vent.
3. Seal all AL29-4C vent joints with approved silicone sealant (400°F - Dow 732 RTV or equivalent)
4. MAINTAIN TWO-INCH CLEARANCE from combustible materials to vent pipe.

5. Long horizontal vent runs should be supported with appropriate hangers. Ensure vent pipe is pitched up from the unit at 1/4” per foot minimum.

6. Direct sidewall vent termination:

- Masonry walls - make a 3 1/2 to 4 - inch diameter hole.
- Combustible material - requires 7-inch hole. Make sheet metal plate with 3-inch hole to cover opening.
- Must be in the same pressure zone (i.e. same outside wall) as the combustion air inlet.

Table 1

Total length for 3" AL29-4C Venting System and 3" Combustion Air Inlet vs number of elbows				
Maximum length - feet	50	45	40	35
Maximum number of elbows	1	2	3	4

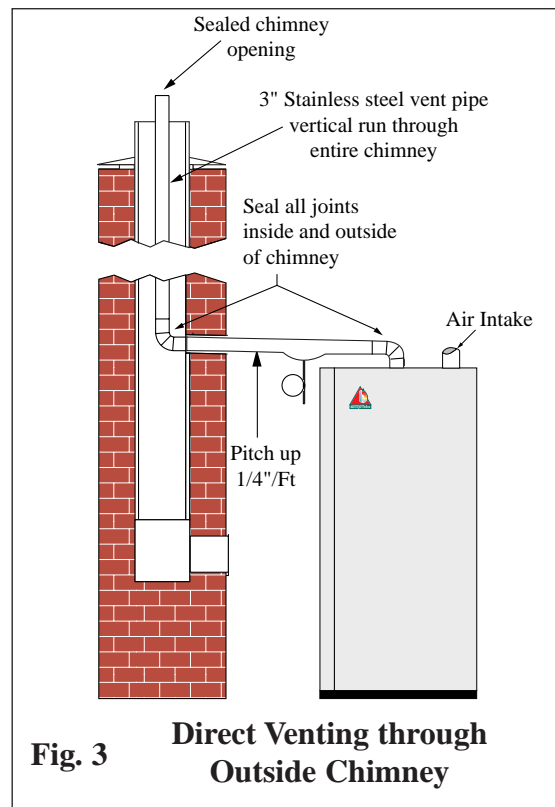
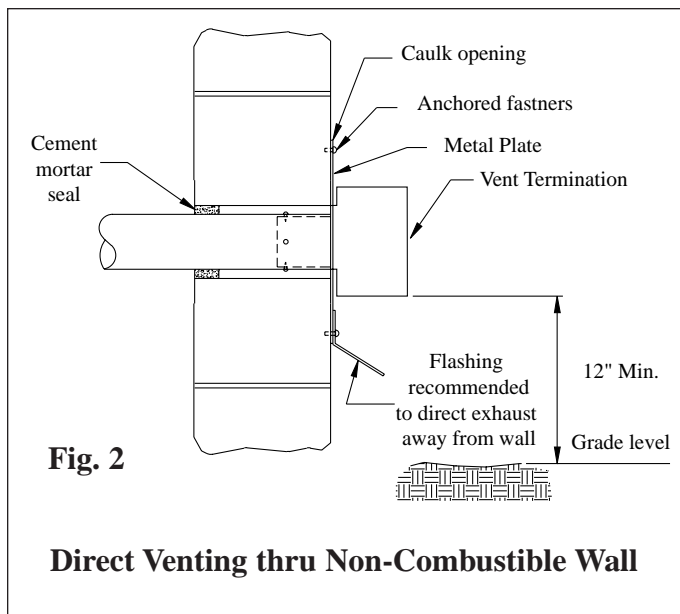

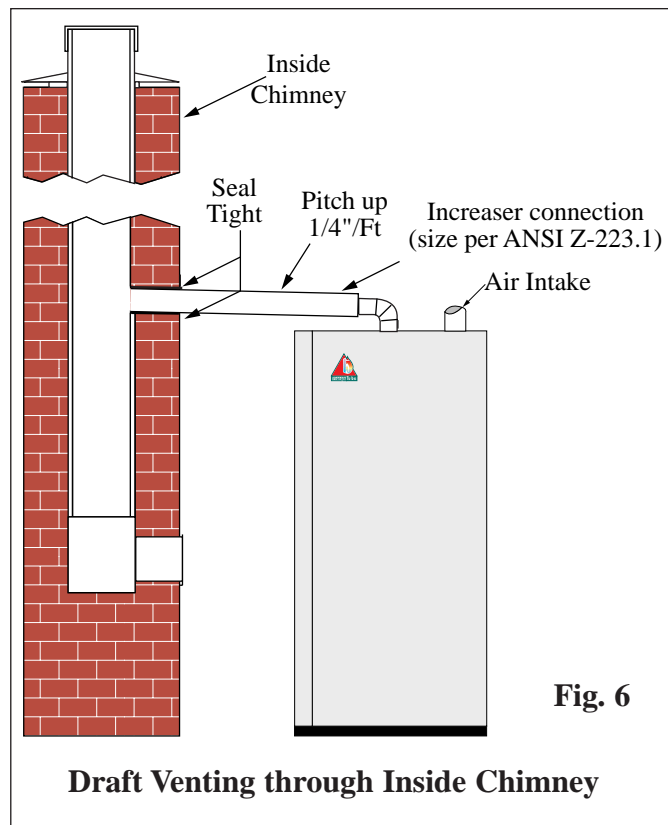
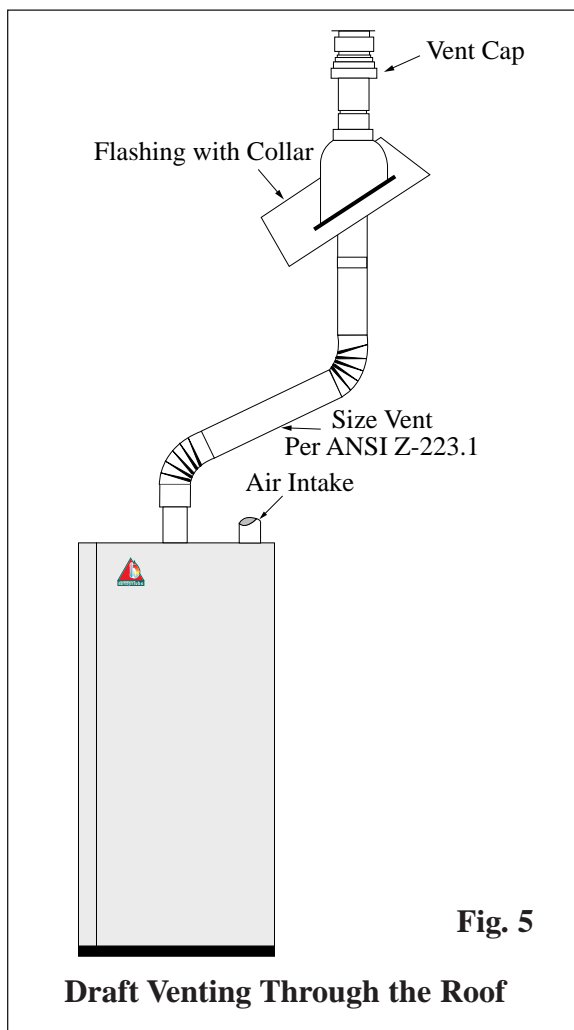
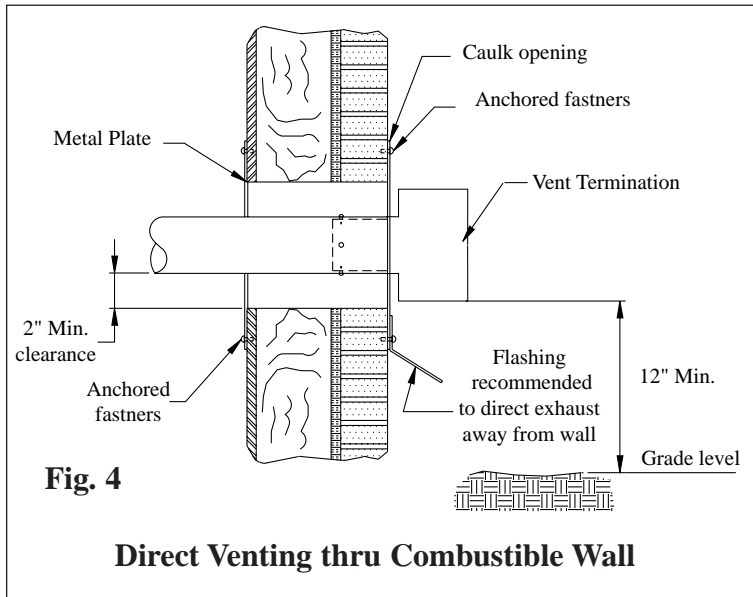

2- PIPING THE COMBINATION HEATER

A-Thermal Expansion

If a backflow preventer, check valve or pressure reducing valve is piped on cold water inlet, install an expansion tank on cold water supply line to prevent normal thermal expansion from repeatedly forcing open T&P relief valve.

CAUTION

T&P relief valve is not intended for constant duty, such as relief of pressure due to repeated normal system expansion. Correct this condition by installing a properly sized expansion tank in domestic water system. Refer to expansion tank manufacturer's instructions for proper sizing.

B- Air Vent

- Automatic air vent is factory installed on the heater.
- Unscrew vent cap on air vent one full turn. Leave cap unscrewed one turn for normal venting.

C- Temperature and Pressure Relief Valve

- T&P relief valve is factory installed on inner tank of the heater.
- T&P relief valve per AGA of 100,000 Btu/hr for G-25.
- T&P relief valve rated per AGA of 200,000 Btu/hr for G-30.
- T&P relief valve discharge piping must be:
 - made of material serviceable for temperatures of 250°F or greater
 - directed so that hot water flows away from all persons.
 - directed to a suitable place for disposal.
 - installed so as to allow complete draining of the T&P relief valve and discharge line.
- T&P relief valve discharge piping **must not** be:

- excessively long. Using more than 2 elbows or 15 feet of piping can reduce discharge capacity.
- directly connected to a drain. Terminate discharge piping within 6" from floor. Refer to local codes.
- plugged, reduced or restricted.
- subjected to freezing.

WARNING

Do not install any valve between T&P relief valve and tank connection, or on T&P relief valve discharge piping. Do not plug T&P relief valve or discharge piping. Improper placement and piping of T&P relief valve can cause severe personal injury, death or substantial property damage.

D- Pressure Relief Valve

- Pressure relief valve is factory installed on outer tank of the heater.
- 30 psig pressure relief valve rated per AGA of 535,000 Btu/hr.
- Provide safe discharge through piping near floor or close to floor drain. Relief valve must be installed so that the spindle is vertical.

WARNING

To avoid scalding or water damage, relief valve discharge must be piped near floor or close to floor drain. Do not plug, valve or place any obstruction in discharge piping.

3. WATER HAMMER

Dishwashers, clothes washers and fast-closing positive shut-off valves incorporated in the system all contribute to creating water shock. Install a water hammer arrester to prevent damage to pipes and appliances. See manufacturer's instructions for application and installation.

4. GENERAL PIPING

- All plumbing must meet or exceed all local, state and national plumbing codes.
- Use pipe dope or tape suitable for potable water on the domestic piping.
- Use isolation valves to isolate system components.
- Install unions for easy removal of combination heater. Use dielectric unions or couplings to protect hot and cold water fittings from corrosion when connecting dissimilar materials such as copper and galvanized iron pipe.
- If plastic is used for primary water connections, it must not exceed a maximum oxygen diffusion rate of 0.1 mg/liter-day for combination heater protection.
- When water supply pressure is higher than T&P relief valve rating, install a pressure reducing valve on cold water supply line to prevent water loss through T&P relief valve.

5. INNER TANK (DOMESTIC) PIPING

- A thermostatic mixing valve and check valve are factory installed on the domestic hot water outlet.
- Install U tube assembly, (factory assembled & provided with the combination heater), to the mixing valve/check valve outlet and to the factory assembly tee at the cold water inlet.
 - If there is a need to alter the piping such as adding a tee upstream of the mixing valve to deliver 140° water to the dish washer, (if local codes permit) the installer must re-install this mixing valve prior to operation of the combination heater.

DANGER

The mixing valve must remain mounted on the domestic hot water outlet at all times. Removal of automatic mixing

valve from combination heater will result in severe personal injury or death.

- For recommended domestic water piping arrangement see Fig. 7 page 11.
- For recommended domestic water piping with recirculation see Fig. 8 page 11.

DANGER

To prevent potential scalding hazard, recirculation must be controlled by an additional aquastat. Do not use continuous recirculation.

6. OUTER TANK SYSTEM PIPING

- Recommended piping shown page 12 and 13.
- Install expansion tank:
 - Diaphragm-type expansion tank. Ensure tank pressure and size will handle system fill pressure and water volume.
 - Fill pressure may be adjusted at tank for design conditions. Follow manufacturer's instructions.
 - Locate expansion tank near the unit, before the inlet of the circulator.

Closed-type expansion tank. Size tank to system requirements. Refer to manufacturer's instructions.

CAUTION

Undersized expansion tanks can cause system water to be lost from relief valve and makeup water added through fill valve. Eventual outer tank failure can result.

- If antifreeze is used in system water, local codes may require a backflow preventer on cold water supply line.

Use antifreeze specifically intended for hydronic heating systems. Inhibited propylene glycol is recommended.

- System water (including additives) must be practically non-toxic, having toxicity rating or class of 1, as listed in Clinical Toxicology of Commercial products.

WARNING

Do not use automotive, ethylene glycol or any undiluted or petroleum-based antifreeze.

This can cause severe personal injury, death or substantial property damage.

- Any water conditioning system must be installed and maintained in accordance with manufacturer's specifications.

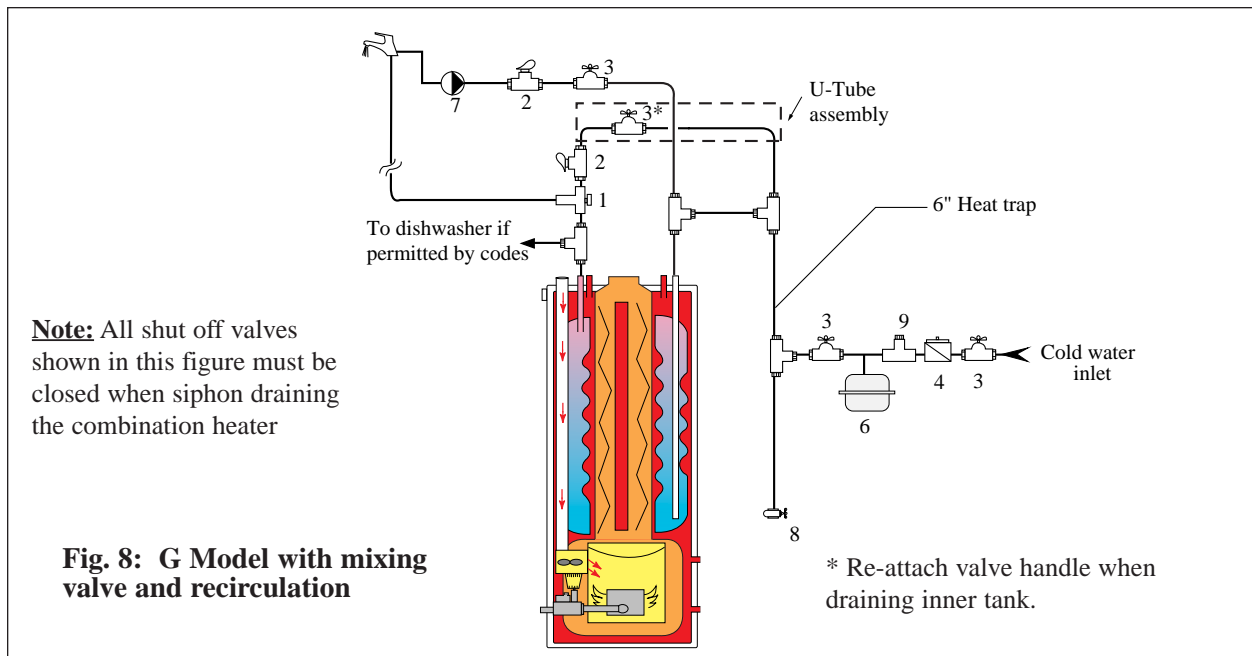
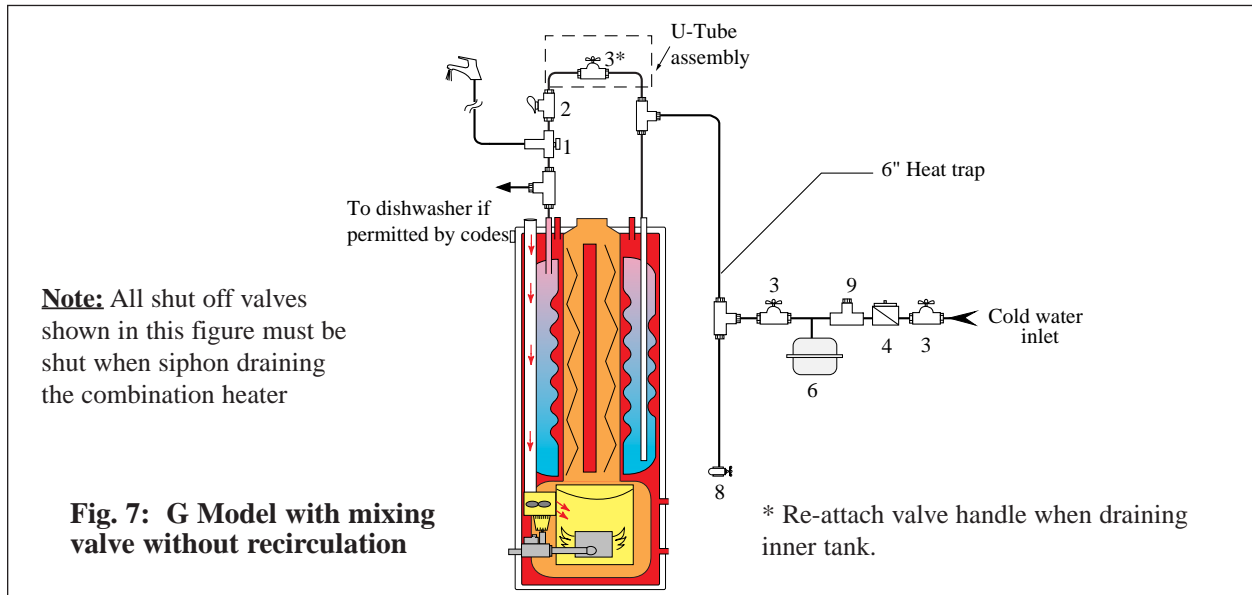

- | | |
|--|--|
| 1. Mixing valve | 6. Thermal expansion tank |
| 2. Flow check valve | 7. Circulator (controlled by aquastat) |
| 3. Shut off valve | 8. Domestic drain valve |
| 4. Backflow preventer or pressure reducing valve | 9. Vacuum breaker (if code permitting) |

Primary Piping -Near Appliance Piping

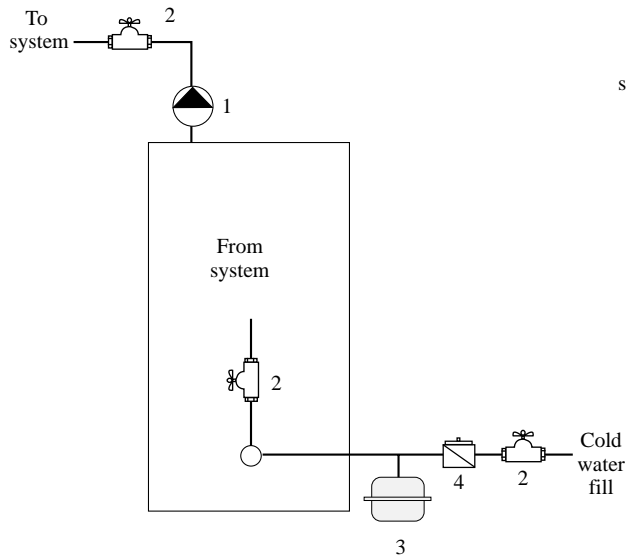

Fig. 9 Piping with diaphragm - type expansion tank

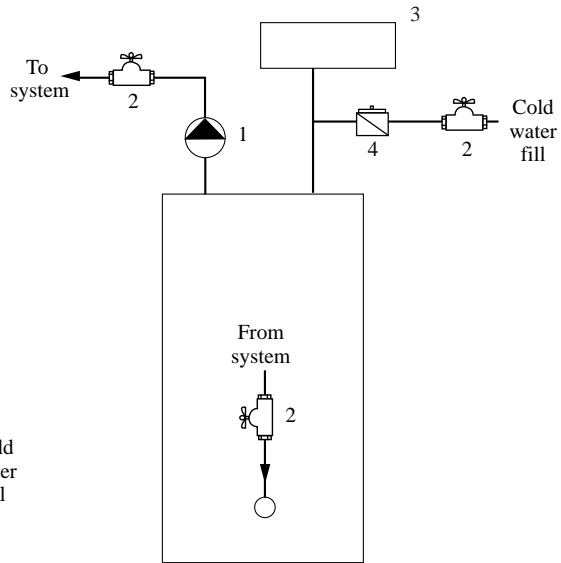

Fig. 9A Piping with closed - type expansion tank

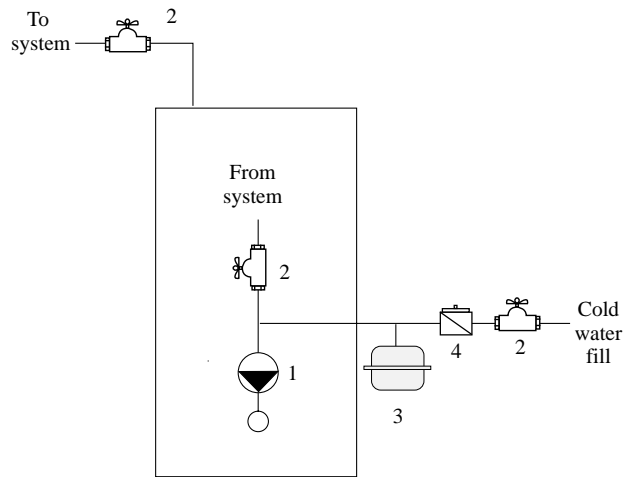

Fig. 9B Piping with diaphragm - type expansion tank (alternate circulator location)

- 1. Circulator
- 2. Manual shut-off valve

- 3. Expansion tank
- 4. Auto fill valve

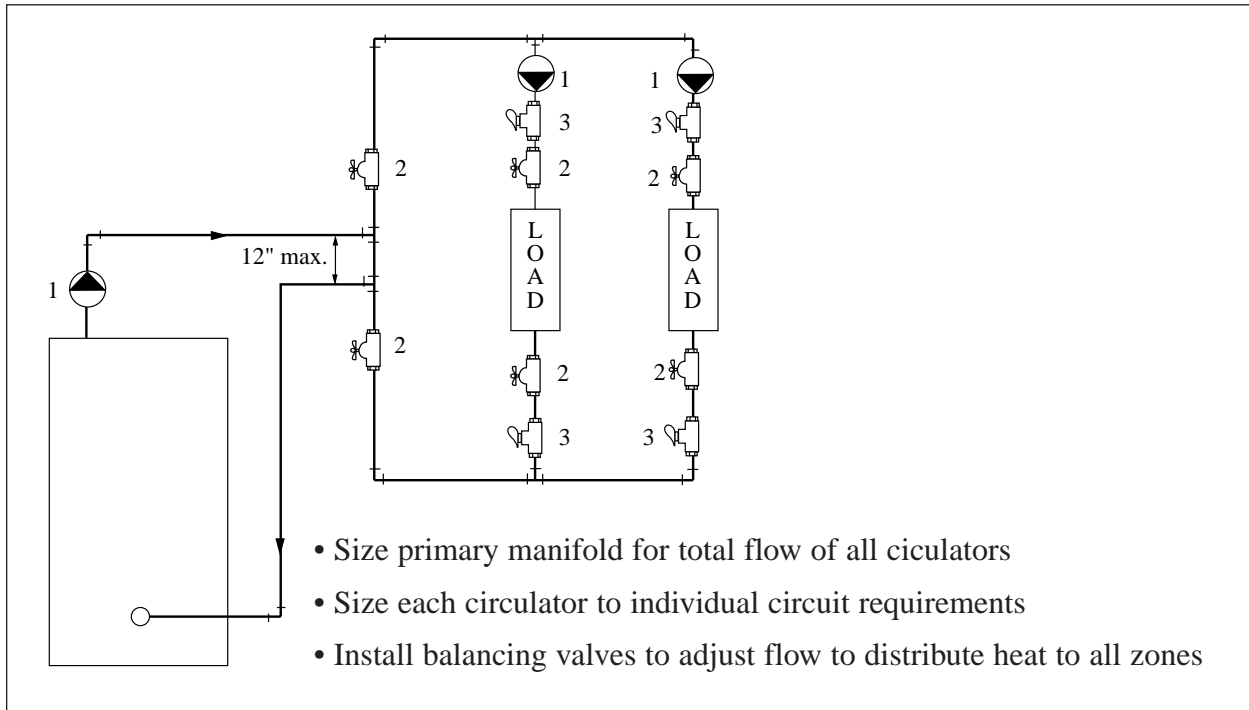

Fig. 10: Primary piping - Zoning with Circulators

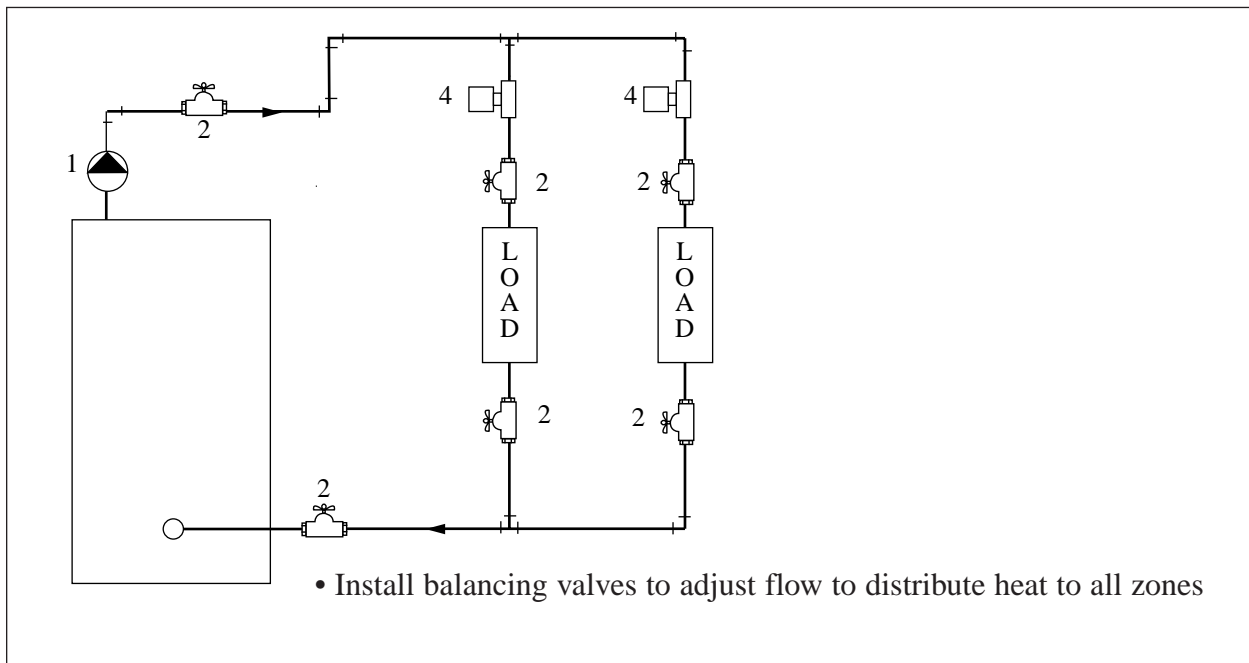

Fig. 11: Primary Piping - Zoning with Zone Valve

1. Circulator
2. Manual shut-off valves
3. Flow check valve
4. Zone valve

Note: See page 12 for near appliance piping.

7- COMBINATION HEATER WIRING

WARNING

Electrical shock hazard. Can cause severe personal injury, death or substantial property damage. Disconnect power before installing and/ or servicing.

Wiring Diagram Requirements

- All wiring must be a minimum of 14 gauge and installed in accordance with:
 - U.S.A. - National Electrical Code and any other national, state or local code requirements having jurisdiction.
 - Canada - C.S.A. C22.1 Canadian Electrical Code Part 1 and any other national, provincial and local code requirements having jurisdiction.
- If original wire, supplied with appliance must be replaced, Type 90°C or its equivalent must be used.

- All electrical contacts shown do not have power applied - off shelf condition.

Zone Valves

- Transformer should be sized for maximum load of all zone valves.

Space Heating

- For single zone space heating wiring, connect 24 V thermostat wiring to combination heater snap-set labeled “Room Thermostat”.

Outdoor Control Limit

- Provided and installed by others
- Remove factory jumper and use terminal 9 & 10

Fig. 12: Wiring Diagram

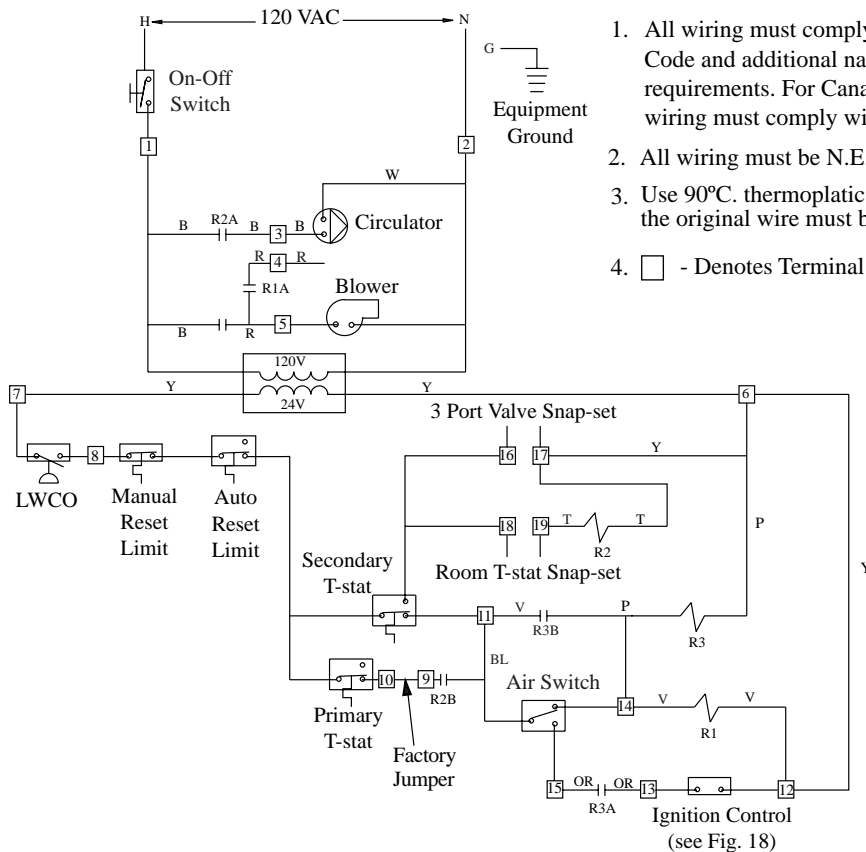

Note

1. All wiring must comply with the National Electrical Code and additional national, state or local code requirements. For Canadian installations, all wiring must comply with the Canadian Electrical Code
2. All wiring must be N.E.C. Class 1.
3. Use 90°C. thermoplastic wire or equivalent, if only the original wire must be replaced.
4. □ - Denotes Terminal Block

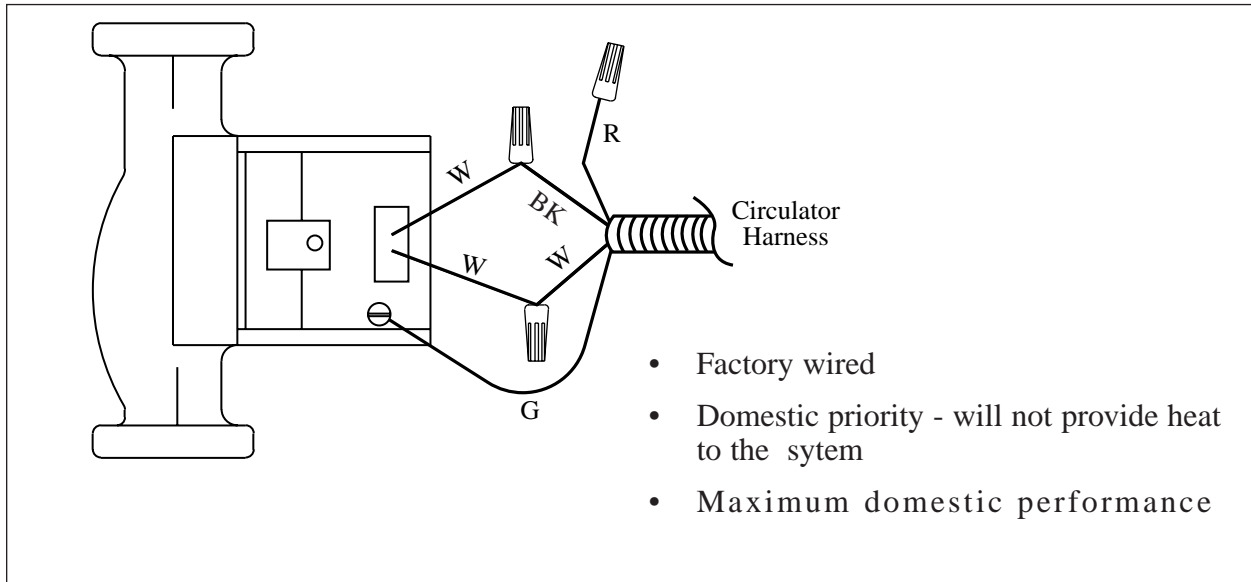

Fig. 13: Circulator wiring - domestic priority

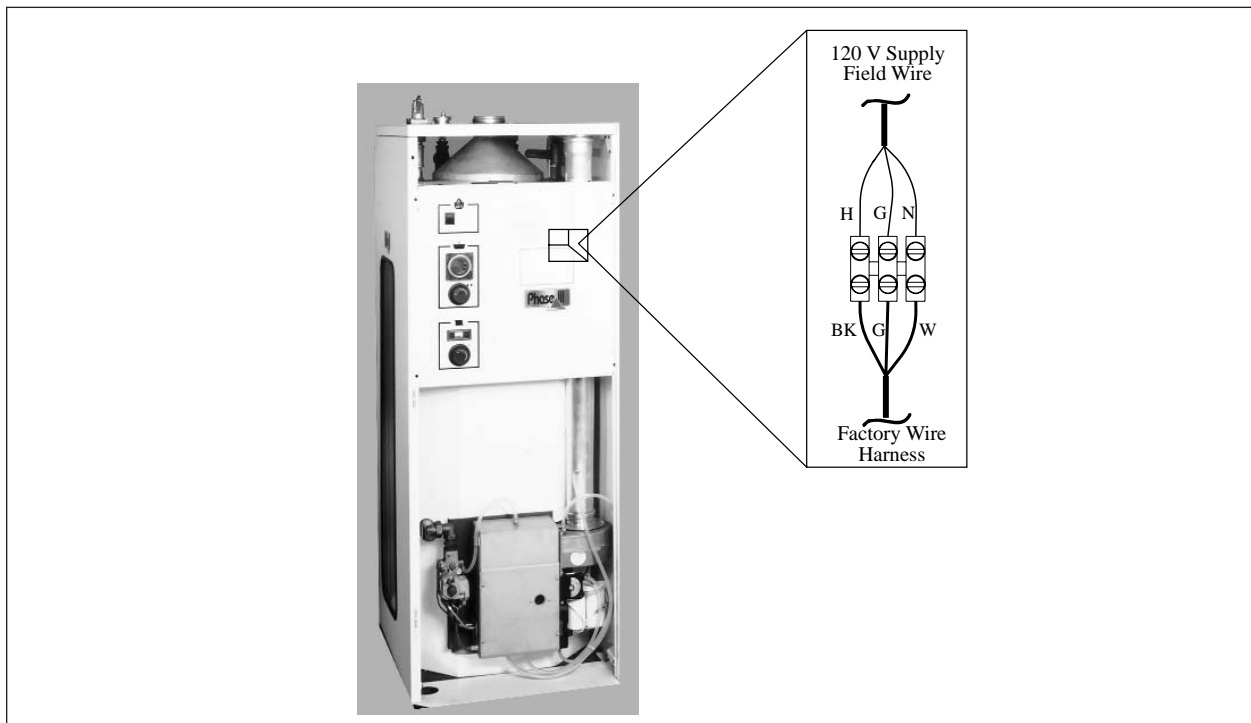

Fig. 14: Power supply wiring - high voltage

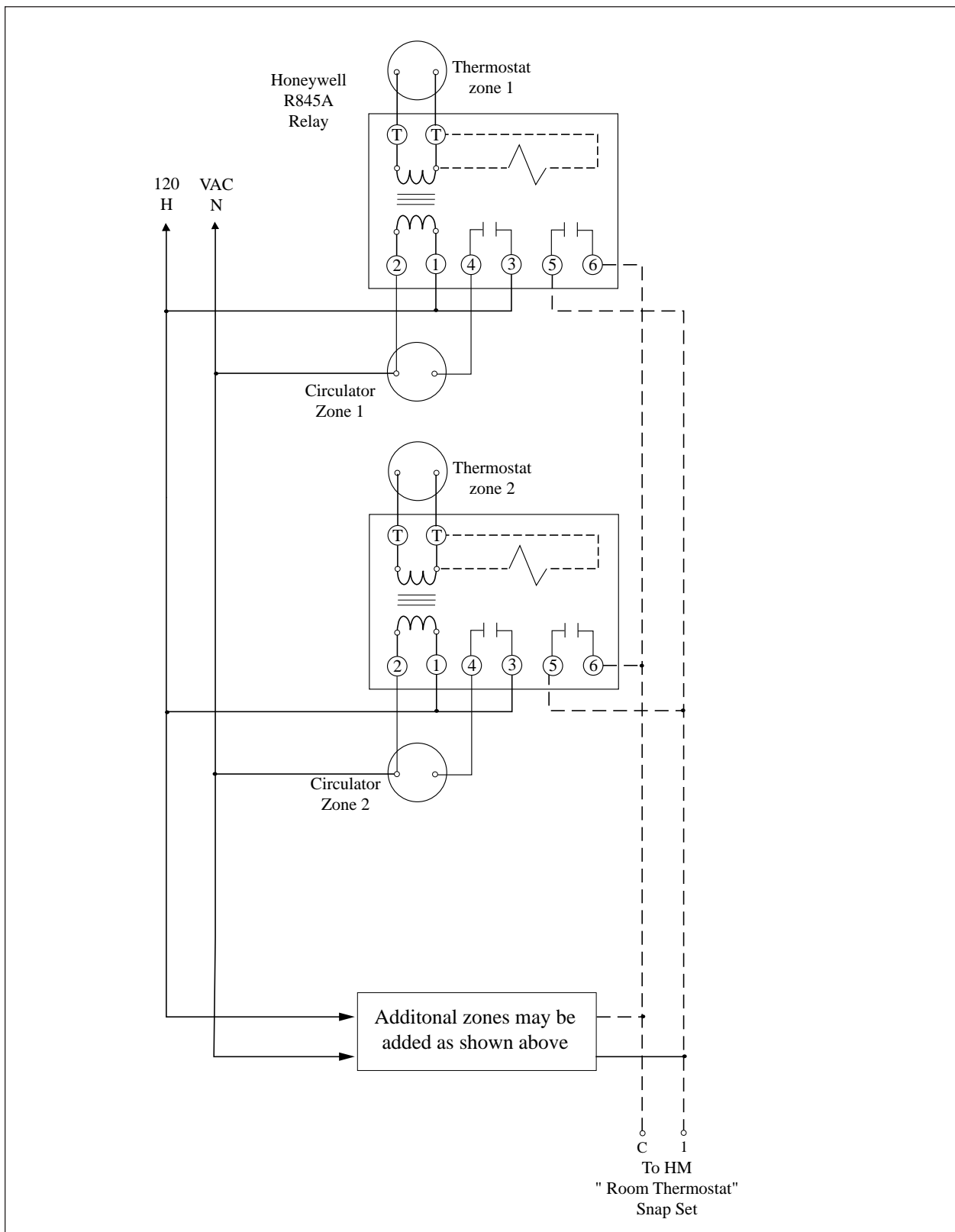
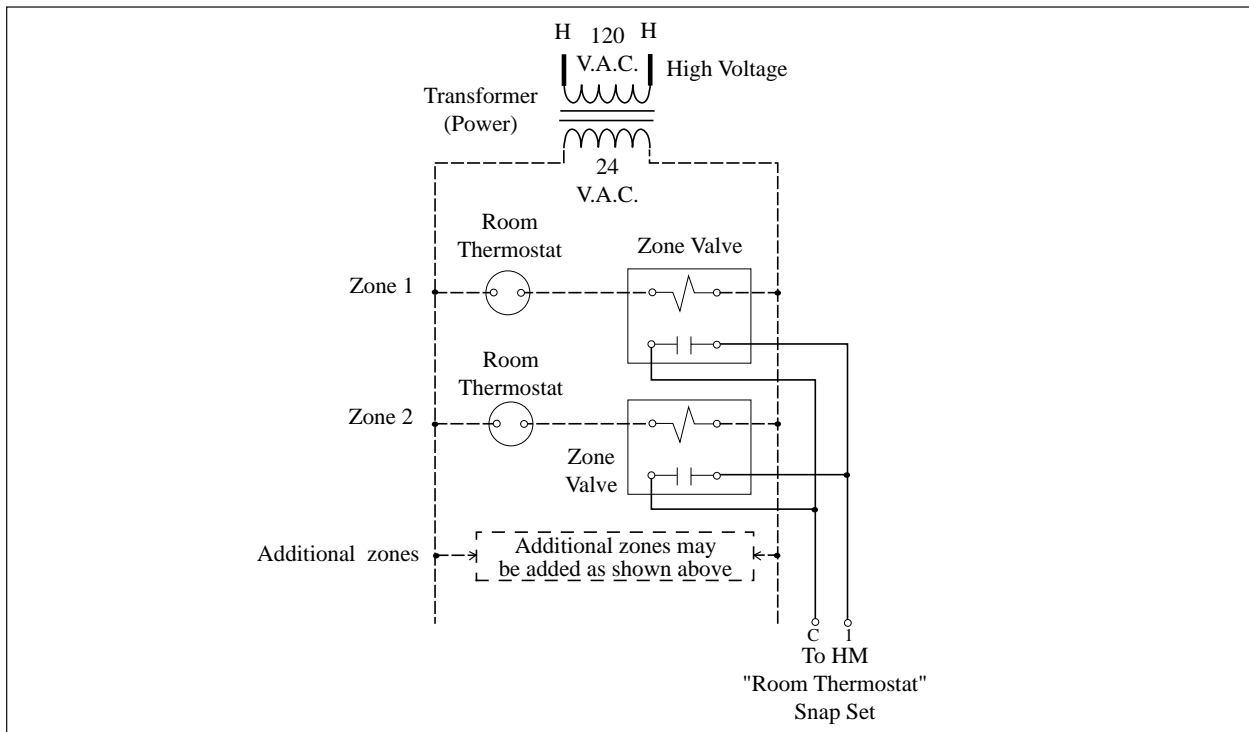

Fig. 15: Field wiring with zone circulators.

4 Wire Zone Valve



3 Wire Zone Valve

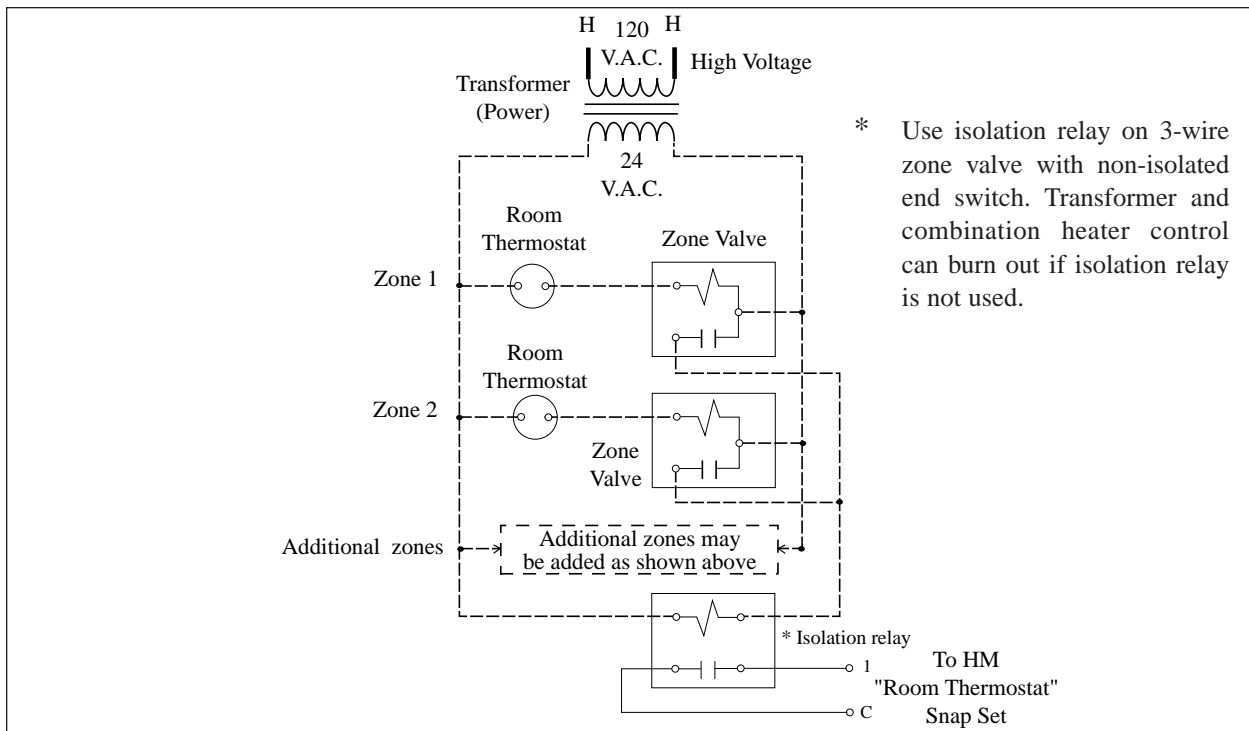

Fig. 16: Multiple zone field wiring using zone valves

1. GAS SUPPLY PIPING

- Check that the gas supply meter has sufficient capacity for the full input of the unit and any other appliances on the meter.
- Refer to Table 2 & 2A page 20 for recommended gas piping.
- Support gas piping with hangers, not by the heater or its accessories.
- Purge all air from gas supply piping.
- Before placing the combination heater into operation check the unit and its gas connections for leaks.
 - Close manual main shut-off valve during any pressure testing at less than 13" W.C.
 - Disconnect heater and gas valve from gas supply piping during any pressure testing greater than 13" W.C.

only to male threads of pipe joints so that pipe dope does not block gas flow.

WARNING

Failure to apply pipe dope as detailed above can result in severe personal injury, death or substantial property damage.

Natural Gas:

1. Refer to Table 2 page 20 for pipe length and diameter. Based on rated combination heater input (divide input by 1,000 to obtain cubic feet per hour).
2. Inlet pressure at gas valve inlet: maximum 14" W.C, minimum 5" W.C.
3. Install 100% lock-up gas pressure regulator in supply line if inlet pressure exceeds 14" W.C. Adjust for 13" W.C. maximum.

WARNING

Do not check for gas leaks with an open flame - use bubble test. Failure to use bubble test or check for gas leaks can cause severe personal injury, death or substantial property damage.

- Use pipe dope compatible with natural and/or propane gas. Apply sparingly

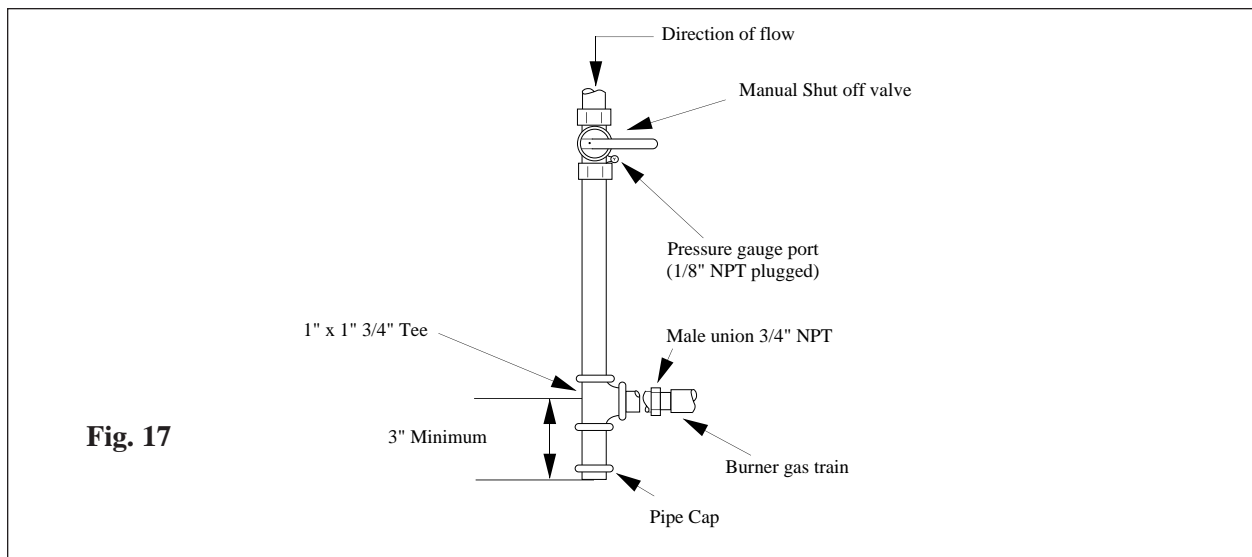

Fig. 17

Table 2: Gas piping sizing - natural gas

Length of Pipe in Feet SCH 40	Capacity of Pipe in Cubic Feet of Gas Per Hour (based on 0.60 specific. gravity, 0.30" w.c. pressure drop)				
	1/2"	3/4"	1"	1-1/4"	1-1/2"
10	132	278	520	1050	1600
20	92	190	350	730	1100
30	73	152	285	590	860
40	63	130	245	500	760
50	56	115	215	440	670
75	45	93	175	360	545
100	38	79	150	305	460
150	31	64	120	250	380

- For additional piping schedules, see ANSI Z223.1
- Canadian installations must comply with CAN/CGA B149.1 or B149.2 Installation Code.

COMBINATION HEATER START UP

1- FILLING THE INNER TANK (Domestic Water)

CAUTION

Never operate combination heater unless it is completely filled with water.

CAUTION

Always fill the inner tank before filling the outer tank to prevent any damage to the inner tank.

1. Close domestic water drain valve
2. Open domestic water isolation valves for combination heater.
3. Vent air from inner (domestic water) tank by opening nearest hot water faucet. Fill domestic water tank completely by allowing water to run until there is a constant flow of water.
4. Close hot water faucet

2- FILLING THE OUTER TANK (Primary Water)

1. Close drain valve at system water outlet of combination heater.
2. Open combination heater's system isolation valves.
3. Allow air to escape from outer (system water) tank by opening cap on automatic air vent, located on top of combination heater.
4. Fill to correct system pressure. Correct pressure will vary with each application. Normal cold water fill pressure is 12 psig.

NOTICE

For proper combination heater operation, always leave vent cap unscrewed one full turn.

5. When tank is full, air will stop escaping and vent will close. If air vent does not seat properly (i.e., water leaks out), remove cap A.

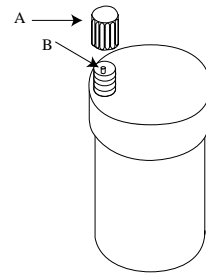

Briefly push in valve B and release it to clean valve seat. Screw cap A on completely, then unscrew one turn.

6. If antifreeze is used in primary water, ensure concentration never exceeds a 50/50 ratio. Primary water (including additives) must be practically non-toxic, having a toxicity rating or class of 1, as listed in Clinical Toxicology of Commercial Products. Inhibited propylene glycol is recommended. Follow antifreeze manufacturer's instructions.

WARNING

Do not use automotive or ethylene glycol antifreeze, or any undiluted antifreeze. This can cause severe personal injury, death or substantial property damage if ignored.

3- BURNER OPERATION

1. Check to see if the HM Combination Heater is filled with water (10-12 psi on Pressure & Temperature gauge on console).
2. Follow operating instructions on page for start-up of the Combination Heater.
3. If appliance fails to start, check for the following conditions:
 - Loose connection or blown fuse at power supply
 - Secondary thermostat set below water temperature
 - Thermostat set below room temperature
 - Gas not turn on at meter or appliance

COMBINATION HEATER START UP

- Incoming natural gas pressure less than 4" W.C, or propane less than 11" W.C.

4. Check burner flames for proper flame pattern:

- Typical -transparent blue
- Overfired - Flames are large
- Underfired - flame are small

- Lack of combustion air - Yellow tipping on flames

4- SYSTEM PIPING

- Check sytem piping for leaks, if found, repair immediately

5- VENTING SYSTEM

- Check the gas tight seal at all vent connection.

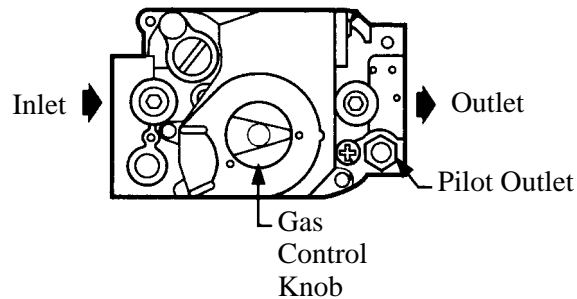

Honeywell VR 8304M

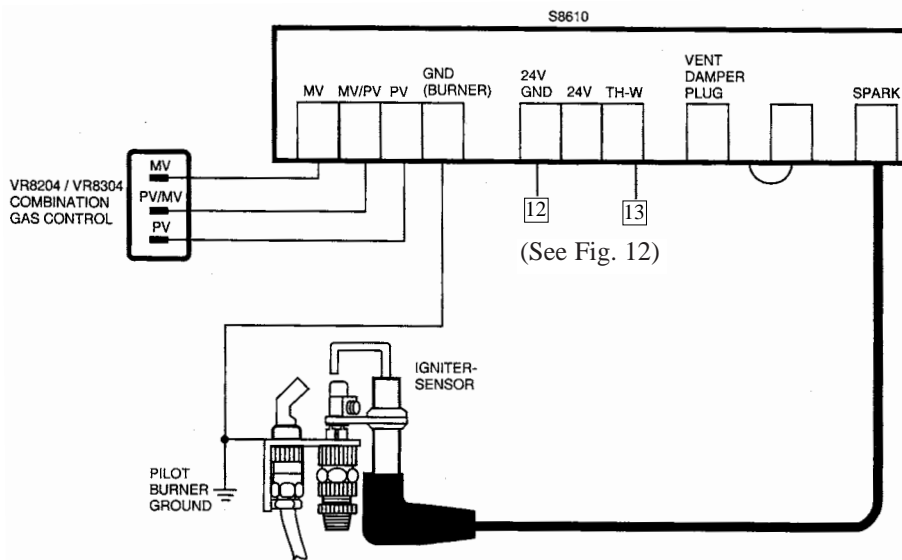

Honeywell S8610

Fig. 18:Intermittent pilot combination Gas Valve & Electronic Ignition Control

FOR YOUR SAFETY READ BEFORE OPERATING

WARNING



The following instructions must be followed exactly, a fire or explosion may result causing property damage, personal injury or loss of life.

1. This appliance is equipped with an electronic ignition system. Do not attempt to light the burner by hand.
2. BEFORE OPERATING, smell all around the appliance area for gas. Be sure to smell next to the floor because some gas is heavier than air and will settle on the floor.
 - Immediately call your gas supplier from a neighbor's phone. Follow the gas supplier's instructions.
 - If you cannot reach your gas supplier, call the fire department.
3. Use only your hand to push in or turn the gas control knob or move the gas control knob. Never use tools. If the knob will not push in or turn by hand, don't try to repair it, call a qualified service technician. Force or attempted repair may result in a fire or explosion.

WHAT TO DO IF YOU SMELL GAS

- Do not try to light any appliance.
- Do not touch any electric switch; do not use any phone in your building

OPERATING INSTRUCTIONS - Honeywell VR8300A

1. **STOP!** Read the safety information above.
2. Set the heating system thermostat to the lowest setting.
3. Turn off all electric power supply to the appliance.
4. Open front jacket panel and ensure the "ON - OFF" switch is the "OFF" position
5. **This appliance is equipped with an electronic ignition system. Do not attempt to light the burner by hand.**
6. Push in gas control knob slightly and turn clockwise  to "OFF" position.
 - 7. Turn the gas control knob counterclockwise  to "ON" position.
 - 8. Reconnect the power supply to the appliance.
 - 9. Reset the unit's "ON-OFF" switch to ON and close the front jacket panel.
 - 10. Set the heating system thermostat to the desired setting.
 - 11. If the appliance will not operate, follow the instructions "To Turn Off Gas To Appliance" and call your service technician or gas supplier.

NOTE: Knob cannot be turn to "OFF" unless knob is pushed in slightly. Do not force.

TO TURN OFF GAS TO APPLIANCE

1. Set the system thermostat to lowest setting.
2. Open front jacket panel and turn "ON-OFF" switch to OFF
3. To turn unit "OFF" follow step 6 in "Operating Instructions" above.
4. Close front jacket panel.

SETTING THE WATER TEMPERATURE

The water temperature control knobs are located on the control console. The set point is indicated by a temperature indicator on the top of the back plate behind the knob. When shipped from the factory the knobs are rotated completely counter-clockwise to the lowest temperature setting. The temperature settings can be increased by rotating the knobs clockwise, see Fig. 19 and 20 below.

- Turn thermostat knob clockwise to increase water temperature.
- Turn thermostat knob counter-clockwise to reduce water temperature.

The recommended temperature settings are 180°F for the primary thermostat and 140°F for the secondary thermostat.

DANGER

Studies have indicated that dangerous bacteria can form in the potable water distribution system if certain minimum water temperatures are not maintained. For prevention of this, it is recommended the secondary thermostat be set at 140°F.

- By storing the water temperature at 140°F or higher, the quantity of domestic water delivered is higher and the customer has additional protection from any bacteria growth.
- The secondary thermostat maintains the minimum domestic water storage temperature.

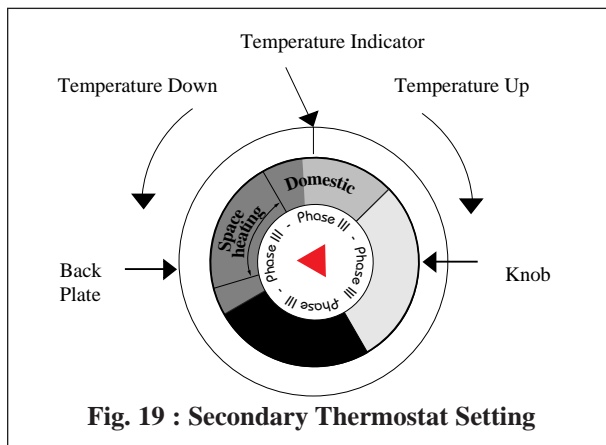

Fig. 19 : Secondary Thermostat Setting

1. SETTING THE COMBINATION WATER HEATER TEMPERATURE LIMITS

- a. See Figs. 19 and 20 for recommended setting.

2. SETTING DOMESTIC WATER TEMPERATURE

DANGER

HOT WATER REPRESENTS A SERIOUS SAFETY HAZARD DUE TO THE POTENTIAL OF SCALDING

A thermostatic mixing valve is **REQUIRED** in the domestic hot water outlet that would allow the domestic water to be supplied at a lower temperature than the storage temperature.

The factory installed thermostatic mixing valve can be adjusted to control domestic supply water at 95°F to 120°F.

Refer to the mixing valve's manufacturer's instructions for setting the desired domestic supply temperature.

DANGER

For proper operation of the thermostatic mixing valve, the shut-off valve located on the U-tube assembly MUST remain open to avoid a potential scald hazard.

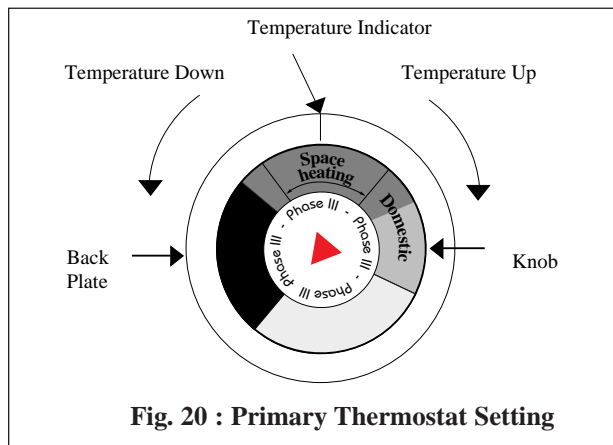

Fig. 20 : Primary Thermostat Setting

COMBINATION HEATER MAINTENANCE

1- ANNUAL MAINTENANCE

A- Flueway

- Must be examined annually.
- Examine flueway by removing the vent pipe, jacket and flue collector from the top of the combination heater.
 - If cleaning is necessary, remove the flue baffles and burner,
 - Sweep with a flue brush or any wire scratch brushes.
 - Remove any particulate that may have fallen into the combustion chamber before replacing the burner.
- Reinstall the flue baffles and flue collector.
- Examine the vent system for any obstruction to the flow of combustion or ventilation air and for deterioration or damage which could cause leakage of flue gases or improper venting.
- Clean, repair or replace as required.

B. Pressure relief valve and T&P relief valves

Manually operate the pressure & T&P relief valves at least once a year. This will release some hot water.

WARNING

Before manually operating either pressure or T&P relief valve check that the discharge is directed to a suitable place for disposal. The discharge line must be full size, without restriction and installed to permit complete drainage of both the valve and line.

T&P relief valve

- Located on the center rear top of the heater. (see Fig. 22 page 29).
- Lift the lever handle and permit water to discharge for several seconds.

- If after closing the valve, the valve fails to completely reset and water continues to flow, shut OFF power to the heater and follow the draining procedure. Partially drain the inner tank and replace the T&P relief valve.
- If T&P weeps periodically, it may be due to thermal expansion (see Thermal Expansion page 9.)

Pressure relief valve

- Located on the left rear top of the outer primary tank. (see fig: 22 page 29)
- Shut OFF the power to the heater.
- Lift the lever handle to permit water to discharge for several seconds.
- After closing the valve, if some water continues to flow, shut OFF the two isolation valves separating the combination heater from heating system. Partially drain the outer tank and replace the pressure relief valve.

WARNING

Water from opened drain valves, unions and other connections may be extremely hot. To avoid personal injury, death or substantial property damage;

- **Tighten all drain hose connections**
- **Direct hot water away from all persons**

C. Antifreeze

- The outer (primary) tank is compatible with inhibited propylene glycol solution with a maximum a 50/50 mix.
- Primary water (including additives) must be practically non-toxic, having toxicity rating or class of 1, as listed in the Clinical Toxicology of Commercial Products.

COMBINATION HEATER MAINTENANCE

WARNING

Do not use automotive or ethylene glycol antifreeze, or any undiluted antifreeze. This can cause severe personal injury, death or substantial property damage;

- Introduction of antifreeze can be done through the drain valve located on the rear bottom of the heater.
- Check the pH value of the concentration. If different than pH 7, the antifreeze must be replaced immediately.

CAUTION

Failing to replace the antifreeze periodically voids the warranty on the combination heater.

- Other undiluted solutions are prohibited and could cause severe personal injury or substantial property damage.

D. Air Vent

- Check air operation
 - Remove vent cap. Briefly push in valve and release it to clean valve seat. Screw vent cap on completely, then unscrew one turn.

CAUTION

When shutting down a unit for an extended period of time, it is recommended to follow the maintenance procedures shown under annual maintenance before restarting the unit.

2- PERIODICAL MAINTENANCE

- Follow instructions on circulator for oiling, if it is oil lubricated.
- Check valves, pipes and fittings for leaks.
- Check functions of field installed controls (see control manufacturer's installations).

- Check thermostatic mixing valve per enclosed manufacturer's installation and maintenance instructions.

3- COMBUSTION CHAMBER

- No maintenance is required for combustion chamber. The combustion chamber is an integral part of the combination heater which can not be removed or replaced.

4- DRAINING THE COMBINATION HEATER

A. Drain Outer Tank

CAUTION

Always drain outer tank before you drain inner (potable water) tank to prevent any damage to inner tank.

1. Disconnect power supply to the HM Combination Heater
2. Close isolation valves to heating system
3. Connect a garden hose to drain valve located bottom/rear of combination heater. Direct the discharge to a safe place of disposal and drain the primary tank.

WARNING

Water from opened drain valves, unions and other connections may be extremely hot. To avoid personal injury, death or substantial property damage;

- Tighten all drain hose connections
- Direct hot water away from all persons.

B. Drain Inner Tank (see Figs. 7 & 8 page 11)

1. Close the shut off valve on the cold water line supply.
2. Connect a hose from the domestic tank drain valve to a floor drain

COMBINATION HEATER MAINTENANCE

3. Re-attach valve handle and close the water shut off valve on the U-tube assembly.
4. Open drain valve.
5. Open and separate the hot water line union or a hot water faucet above the combination heater. This will initiate the siphoning procedure.
6. To refill and put the HM Combination Heater back in operation, follow the instruction under "Filling the Inner Tank" page 20 .
7. Open the water shut-off valve on the U-Tube assembly and remove handle

C. When Space Heating System Contains Sufficient Anti-Freeze

1. Disconnect power supply to combination heater

2. If system pressure is greater than 15 psig, relieve system pressure before proceeding.

CAUTION

System pressure must not exceed 15 psig to prevent damage to inner tank.

3. Follow the procedures for draining the inner tank. The outer tank does not require draining.
4. When draining is complete
 - close drain valve
 - remove hose

SPECIFICATIONS DATA

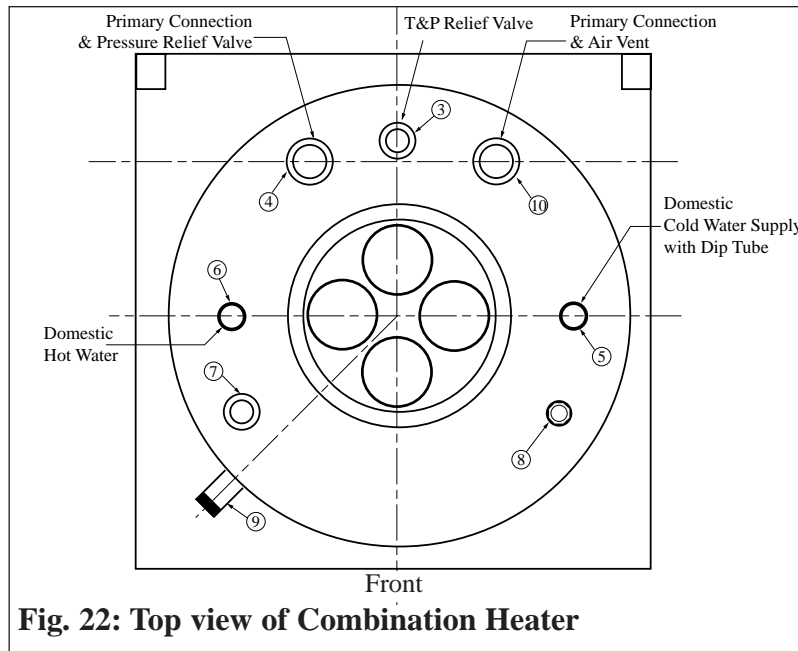
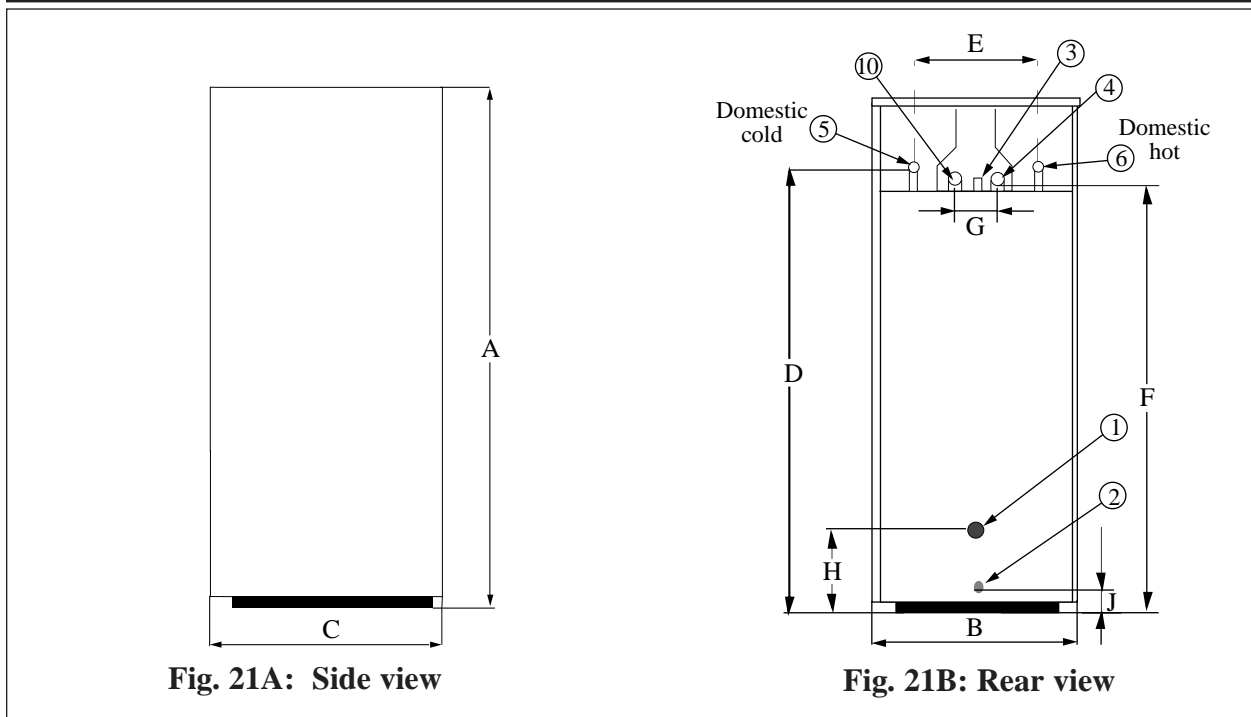

LEGEND

- | | |
|---|--|
| <ol style="list-style-type: none"> 1. Primary circuit, ϕ 1" NPT 2. Primary circuit drain valve connection, ϕ 1/2" NPT 3. Domestic temperature/pressure relief valve (150 psi), ϕ 3/4" NPT 4. Primary circuit & pressure relief valve (30 psi), ϕ 1" NPT 5. Domestic cold water inlet, ϕ 3/4" NPT | <ol style="list-style-type: none"> 6. Domestic Hot water outlet & secondary thermostat sensor, ϕ 3/4" NPT 7. Automatic reset safety sensor & LWCO pressure sensor, ϕ 3/4" NPT 8. Primary pressure & manual reset safety sensor, ϕ 1/2" NPT 9. Primary thermostat sensor, & primary temperature indicator, ϕ 1/2" NPT 10. Primary circuit & air vent, ϕ 1" NPT |
|---|--|

SPECIFICATIONS DATA

Chart 3: Dimensional Data

Type		HM G-25	HM G-30
Input	Btu/hr	100,000	120,000
Inner Tank Capacity	Gal	20	20
Outer Tank Capacity	Gal	22	22
Dimensions	Inches		
A		59	59
B		21	21
C		28	28
D		54.5	54.5
E		14	14
F		54	54
G		8	8
H		16	16
Vent size	∅	3"	3"
Connections:			
TP Valve (domestic)	∅	3/4"	3/4"
Domestic water	∅	3/4"	3/4"
Primary connection	∅	1"	1"
Drain	∅	1/2"	1/2"
Empty weight	lb	363	363
Heat exchanger surface	Sq. Ft.	17	17

Chart 4: Performance

Model	10 min. Peak Flow		1st Hour		Continuous Flow
	Storage Temp.		Storage Temp.		
	140°F	180°F	140°F	180°F	80°F
G-25	46	56	153	163	128
G-30	51	61	178	188	153

Chart 5

Item	Part No.	Description	Quantity required by Model
			HM G 25, 30
1		Jacket, Front	1
2		Jacket, Door	1
3		Jacket, Left side	1
4		Jacket, Right side	1
5		Jacket , Back	1
6		Jacket, Top cover	1
7		Control panel console	1
8	HMSWI02	ON/OFF switch	1
9	HMG AU01	Temp./Pres. gauge	1
10	P3THT01	Operating T'Stat.	2
11	P3KWB01	Knob	2
12	P3BZL01	Bezel	2
13	HMC0N01	Manual Reset T'Stat	1
14		Flue Collector - 3"	1
15		Turbulators	4
16	HMLPVO1-35	T & P Relief Valve 150 psi	1
17	HMLRV01	Pressure Relief Valve 30 psi	1
18	P3AVT01	Auto. Air Vent	1
19	P3BSH01	Bushing 1/8"x1/2"	1
20	HMLWC01	Pres. SW. (L.W.C.O.)	1
21	P3DT04	Dip Tube	1
22	HMDRA01	Drain Valve	1
23	HMTH01	Auto reset safety thermostat	1
24	P3VLV01	Mixing valve	1
25	HMCKV01	Check valve - in line	1
26	HNSNP01	Snap sets	2

All technical data are subject to change without notice

SAMPLE SPECIFICATION - GAS FIRED

Phase III® HM Series Gas Fired
Combination Heater HM G Model _____ or
equal.

1. The Combination Heater(s) shall be Phase III® Model _____ having gas input of _____ BTU/hr and a recovery rate of _____ GPH at 100° temperature rise.
2. The construction consists of an annular stainless steel heat exchanger with center flueway, immersed in a primary fluid for indirect firing.

The primary fluid - also cooling off the base of the combustion chamber - prevents a direct contact of the flame and combustion gases with the corrugated hot water tank. This unique design insures a possible 180° F continuous hot water production .

3. The heat exchanger made with high grade stainless steel shall have a minimum of 17 Square Feet of heat transfer surface and will be corrugated. The working pressure rating shall be 150 Psi.

4. The combination heater shall be factory - equipped with two adjustable thermostat at 125-180 °F, and a safety limit aquastat set at 200°F with manual reset.

The outer tank containing the primary fluid shall be protected by a Low Water Cut-Off device, and a pressure relief valve set at 30 Psi.

The inner tank shall be protected by a 150 Psi Temperature and Pressure Relief Valve.

6. The complete unit(s) shall be insulated with rigid polyurethane foam insulation and installed in a steel cabinet which has been finished with a baked enamel paint.
7. The combination heater shall be covered by a limited Five-year warranty against leaks and corrosion.
8. The combination heater shall be equipped with a sealed gas burner with force draft vent system.

For your own convenience and information, please fill out the following:

CONTRACTOR/INSTALLER:

Name: _____

Address: _____

Phone Number: _____

Date Installed: _____

**Additional quality water heating equipment available
from
Triangle Tube/Phase III**

Phase III Indirect Fired Water Heaters



- Exclusive Tank-in-Tank design
- Stainless steel construction
- Available in 8 sizes and 2 models
- Limited LIFETIME residential warranty
- 15 year limited commercial warranty
- Self cleaning/self descaling design

TTP Brazed Plate Heat Exchangers

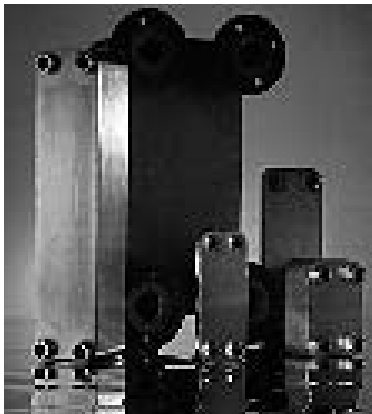

- For domestic water, snow melting, radiant floor, refrigeration
- Plates made of stainless steel, with a 99.9 % copper and brazed, ensuring a high resistance to corrosion
- Self cleaning and self descaling
- Computerized sizing available from Triangle Tube/Phase III
- Available in capacities from 25,000 BTU/hr to 5,000,000 BTU/hr

Maxi-flo Pool and Spa Heat Exchangers



- Construction of high quality corrosion resistant stainless steel (AISI 316)
- Specially designed built-in flow restrictor to assure maximum heat exchange
- Compact and light weight
- Available in 5 sizes that can accommodate any size pool or spa



Freeway Center - 1 Triangle Lane - Blackwood, NJ 08012
Tel: (856) 228 8881 - Fax: (856) 228 3584
<http://www.triangletube.com>
E-mail: Sales@triangletube.com

Member of

