



INSTALLATION & SERVICING

LOGIC AIR CYLINDER

UNVENTED MAINS PRESSURE
HOT WATER STORAGE

When replacing any part on this appliance, use only spare parts that you can be assured conform to the safety and performance specification that we require. Do not use reconditioned or copy parts that have not been clearly authorised by Ideal Heating. For the very latest copy of literature for specification and maintenance practices visit our website idealheating.com where you can download the relevant information in PDF format.



These instructions should be read in conjunction with the installation/servicing instructions issued by the manufacturer of the heat source being used.

Any installation must be in accordance with the relevant requirements of the Gas Safety Regulations, Building Regulations, I.E.E. Wiring Regulations and the Water Fitting Regulations (England and Wales) or Water Byelaws (Scotland). It should be read in accordance with the relevant recommendations of the following:

BS 6798; BS EN 12828, BS EN 12831, BS EN 14336; BS 5546;

BS 5440:1; BS 5440:2; CP 331:3

BS EN 806-1 to 5, BS EN 8558:2011; BS EN 1458-1:2011 and BS 7593:2006

The Logic Air Cylinder is covered by Section G3 of the Building Regulations (England and Wales) Technical Standard P3 (Scotland) and Building Regulation P5 (Northern Ireland). Compliance can be achieved via a Competent Person Self Certification Scheme or notification of installation to the Local Authority Building Control Department.

It must be installed by a competent person as defined by the relevant regulations. Manufacturers notes must NOT be taken as over-riding statutory obligations.

This appliance is not intended for use by persons (including children) with reduced physical, sensory or mental capabilities, or lack of experience and knowledge unless they have been given supervision or instruction concerning use of the appliance by a person responsible for their safety. Children should be supervised at all times to ensure they do not play with the appliance.

This information is provided to assist generally in the selection of equipment. Responsibility for selection and specification of our equipment must however remain that of our customer and any experts or consultants concerned with the installation(s).

Please note: that we do not therefore accept any responsibility for matters of design selection or specification, for the effectiveness of an installation or system containing one of our products unless specifically requested to do so in writing.

All goods are sold subject to our Conditions of Sale which are set out at the rear of this specification. In the interest of continuously improving the Logic Air Cylinder range, Ideal Heating Ltd reserve the right to modify the product without notice, and in these circumstances this booklet, which is accurate at the time of printing, should be disregarded. An updated set of Instructions will be produced and supplied with new appliances and will be made available for other appliances on request.

Logic Air is produced under an ISO 9001:2008 Quality Management System approved by BSI.



Benchmark places responsibilities on both manufacturers and installers. The purpose is to ensure that customers are provided with the correct equipment for their needs, that it is installed, commissioned and serviced in accordance with the manufacturers instructions by competent persons and that it meets the requirements of the appropriate Building Regulations. The Benchmark Checklist can be used to demonstrate compliance with Building Regulations and should be provided to the customer for future reference.

Installers are required to carry out installation, commissioning and servicing work in accordance with the Benchmark Code of Practice which is available from the Heating and Hot Water Industry Council who manage and promote the Scheme.

Visit www.centralheating.co.uk for more information.

For further information on the HWA Charter Statement, please refer to the HWA website hotwater.org.uk.

Section	Page
DESIGN	
Key Information	3
Technical Data and Drawings	4
Component Identification and Product Description	14
HEAT PUMP CYLINDER SELECTION GUIDE	
	22
WARNINGS/CAUTIONS	
	23
INSTALLATION	
Installation	24
USER INSTRUCTIONS	
	35
SERVICING AND MAINTENANCE	
Servicing and Maintenance	34
Fault Finding	35
Spare Parts List	36
APPENDIX	
Appendix A	37
Appendix B	38
Terms & Conditions	39
Benchmark Checklist	40
Benchmark Service Record	41



The code of practice for the installation, commissioning & servicing of central heating systems

WEEE DIRECTIVE 2012/19/EU
Waste Electrical and Electronic Equipment Directive

- At the end of the product life, dispose of the packaging and product in a corresponding recycle centre.
- Do not dispose of the unit with the usual domestic refuse.
- Do not burn the product.
- Remove the batteries.
- Dispose of the batteries according to the local statutory requirements and not with the usual domestic refuse.

DESIGN

Manufacturer: Gledhill Building Products Ltd

Maximum inlet pressure to Pressure reducing valve	12 bar, 22mm compression
Operating pressure (PRV setting)	3 bar
Expansion vessel charge pressure	3 bar, 3/4" BSPM
Expansion relief valve setting (maximum design pressure on the drinking water side)	4.5 bar, 15mm compression
Opening pressure of P & T Relief Valve (SG019 (309463 GLD))	6 bar, 1/2" BSPM
Opening temperature of P & T Relief Valve (SG019 (309463 GLD))	90 - 96°C
Energy cut-out thermostat setting	80 +/-5, or 82 +0,-5 °C
Max. working pressure - Heat pump heat exchanger	3 bar
Immersion heater rating	3kW, 240V AC

All cylinders are manufactured in accordance with the requirements of BS EN 12897:2016. The tundish must be positioned so that it is visible to the occupant and is away from electrical devices.

Pre-plumbed unvented cylinder components include:

- Inlet control group, inc. Pressure reducing valve, balanced cold feed port, check valve, expansion vessel connection point, expansion relief valve
- Pressure and temperature relief valve
- Tundish
- Cylinder drain valve, on cold inlet elbow, (22mm elbow with MT cock)
- Correctly sized expansion vessel (supplied not fitted)

Pre-wired controls include (connected to the control box)

- DHW temperature control thermistor
- DHW cylinder overheat thermostat

Pre-plumbed Primary system components (may vary on model selected)

- HP flow and return temperature thermistor
- Full divert spring close 3 port valve, motor open for DHW heating
- Low loss header, inc drain point
- System bypass valve, 150 models only
- System filter fitted to the HP return, inc isolation valves
- Auto air vents on DHW coil inlet
- Auto air valve on central heating returns, DUO models only
- Central heating zone pump, not on 150 models, inc isolation valves
- System filling loop

In any situation where the volume of heated pipework (eg. secondary circulation pipes or manifold pipework for multiple units) exceeds 10 litres, then an additional expansion vessel must be fitted to accommodate the extra expansion volume.

Handling Before Installation

Logic Air Cylinder must be handled with care and stored the correct way up in a dry place. Any manual handling/lifting operations will need to comply with the requirements of the Manual Handling Operations Regulations issued by the H.S.E. The appliance is supplied attached to a small pallet, and can be moved around on smooth level surfaces using a pallet truck. In more confined spaces the appliance can be moved using a sack truck on the rear face although care should be taken and the route should be even. In apartment buildings containing a number of storeys we would recommend that the appliances are moved vertically in a mechanical lift. If it is proposed to use a crane, expert advice should be obtained regarding the need for slings, lifting beams etc.

A specific manual handling assessment is shown in Appendix B at the rear of this manual (Weights of the products are included in the data tables included in this manual).

The Environment

This product has been manufactured using many recyclable materials, including the approved HCFC/CFC free polyurethane foam insulation. At the end of its useful life, it should be disposed of at a Local Authority Recycling Centre, to maximise the products full environmental benefits.

Maintenance

Modifications should not be made to this product. Replacement parts, including immersion heaters, should be purchased from Ideal Heating Limited, or agents approved by them. Unvented hot water storage vessels need regular routine checks, and these are detailed below. It is for this reason that this manual must always be left with the Logic Air Cylinder.

It is essential that these checks be carried out at the time of unvented cylinder maintenance by a qualified installer:

1. Manually open the relief valves in turn, and check that water is discharged from the valves and runs freely through the tundish and out at the discharge point. Ensure that the valves re-seat satisfactorily. (Note - the water may be very hot).
2. It is important to check that the discharge pipework is carrying the water away adequately. Check for blockages etc. if it is not.
3. Isolate the cold supply to the cylinder. Remove the inlet control group valve. Inspect the gauze filter on the inlet side of the valve and remove the debris.
4. Check the charge pressure in the expansion vessel and repressurise if required
5. Re-fill the system and ensure that all relief valves have re-seated.
6. The Benchmark Service Record should be updated at each service.
7. Check the water pressure downstream of the combination valve is 3 bar in static condition.
8. Check and if necessary, descale the heat exchanger in hard water areas ie. above 200ppm (mg/l).

Note:

All the Logic Air Cylinders can be inspected internally by draining the cylinder, removing the immersion heater completely, and inserting an endoscope through the immersion boss. The cylinder is factory fitted with a temperature & pressure relief valve that must not be used for any other purpose or removed.

The cylinder is factory fitted with immersion heaters with thermal cut outs. Immersions without thermal cut outs must not be fitted.

DESIGN

Table 1 Logic Air Single Zone Preplumbed Cylinders

General Description		150, 180; litre; 475 mm & 550 mm diameter; single coil cylinders intended for coupling with a range of heat pumps 5 kW to 14 kW; Pre-plumbed and pre-wired including control box. Intended for a single zone heating system installation.			
Assembly Model code/number		LOGIC AIR DHW CYL PP 150 CBOX 1Z SL	LOGIC AIR DHW CYL PP 180 CBOX 1Z SL	LOGIC AIR DHW CYL PP 150 CBOX 1Z	LOGIC AIR DHW CYL PP 180 CBOX 1Z
Cylinder model code/number		IDEPLUHP150PPSZL	IDEPLUHP180PPSZL	IDEPLUHP150PPSZ	IDEPLUHP180PPSZ
Energy Efficiency Class		B	C	B	B
Heat Loss	Watts	50	58	44	49
	kWh/24h	1.21	1.40	1.07	1.18
Capacity (DHW content)	Litres	145	169	148	170
Volume heated by immersion heater	Litres	134	165	127	157
Weight Empty	kg	39	46	37	41
Weight Full	kg	185	215	185	212
Pressure Reducing valve setting	bar	3	3	3	3
Expansion relief valve setting	bar	4.5	4.5	4.5	4.5
Temperature setting of TPRV	°C	95	95	95	95
Pressure setting of TPRV	bar	6	6	6	6
Potable Expansion Vessel size.	Litres	18	18	18	18
Expansion Vessel charge	bar	3	3	3	3
Maximum horizontal dimension	mm	555	555	625	625
Maximum vertical dimension	mm	1595	1867	1193	1381
Overall Diameter	mm	A 475	A 475	A 550	A 550
DHW outlet	mm	B 1579	B 1851	B 1177	B 1365
Cylinder Height	mm	C 1519	C 1791	C 1118	C 1306
TPRV port	mm	D 1292	D 1564	D 875	D 1063
Manual reset overheat thermostat pocket	mm	E 1051	E 1151	E 673	E 673
Primary flow	mm	F 544	F 544	F 544	F 544
Secondary return port	mm	G -	G -	G -	G -
Thermistor pocket	mm	H 668	H 759	H 532	H 584
Primary return	mm	J 95	J 95	J 95	J 95
Immersion heater pocket	mm	K 230	K 230	K 230	K 230
Cold water inlet	mm	L 1516	L 1788	L 1099	L 1287
Cylinder Drain	mm	M 220	M 220	M 220	M 220
CH1 Flow	mm	N 479	N 479	N 479	N 479
CH2 Flow (n/a to SZ version)	mm	P -	P -	P -	P -
CH Return	mm	Q 95	Q 95	Q 95	Q 95
Buffer Connections	mm	R -	R -	R -	R -
Buffer Inspection	mm	S -	S -	S -	S -
Buffer Drain	mm	T -	T -	T -	T -
Primary heat exchanger surface area	m ²	1.8	3.0	1.6	2.5
Primary heat exchanger capacity	Litres	6.4	10.6	5.6	8.5
Primary heat exchanger thermal rating ¹	kW	33.2 (15.2)	39.3 (20.7)	25.7 (13.1)	32.8 (17.8)
Primary heat exchanger pressure loss ¹	bar	0.082	0.048	0.061	0.095
Heat up time from 10°C to 60°C (50°C)	min	13.88 (22.26)	15.75 (21.81)	16.4 (22.56)	17.62 (22.56)
V40	Litres	215.7 (158.9)	291 (205)	198.2 (139.8)	270 (186)
Revision Level		D8.2	D8.2	D8.2	D8.2

Measured at 0.25 (0.42) l/s primary flow rate and at 80 (55)°C flow temperature, tested to BS EN 12897:2016, figures in brackets show figures for HWA 002:2020 heat pump test results.

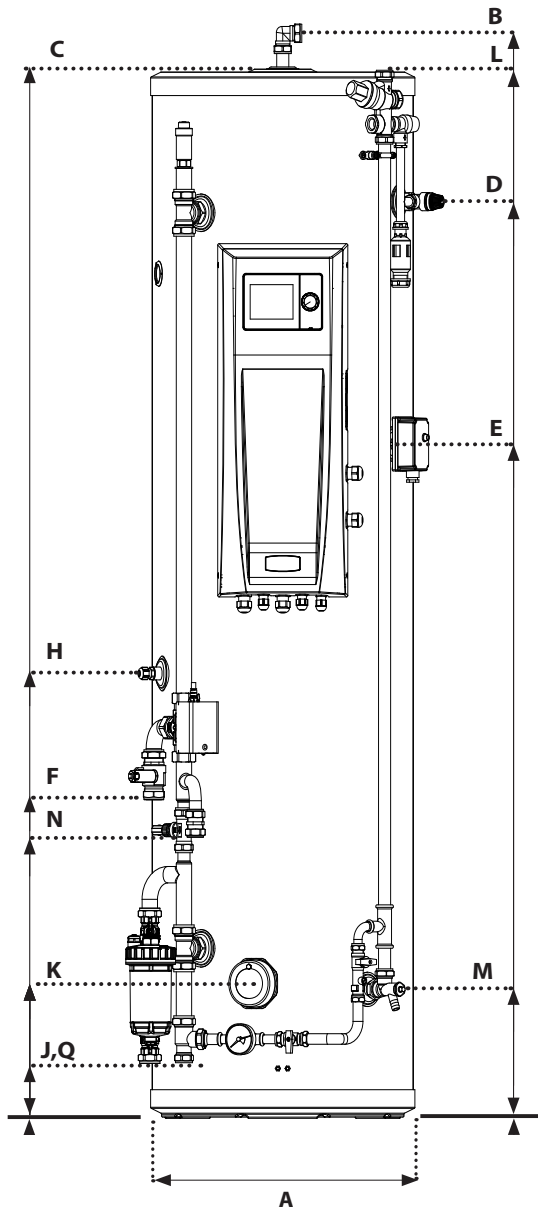

IDEPLUHP180PPSZL
PP Single Zone - 475 mm

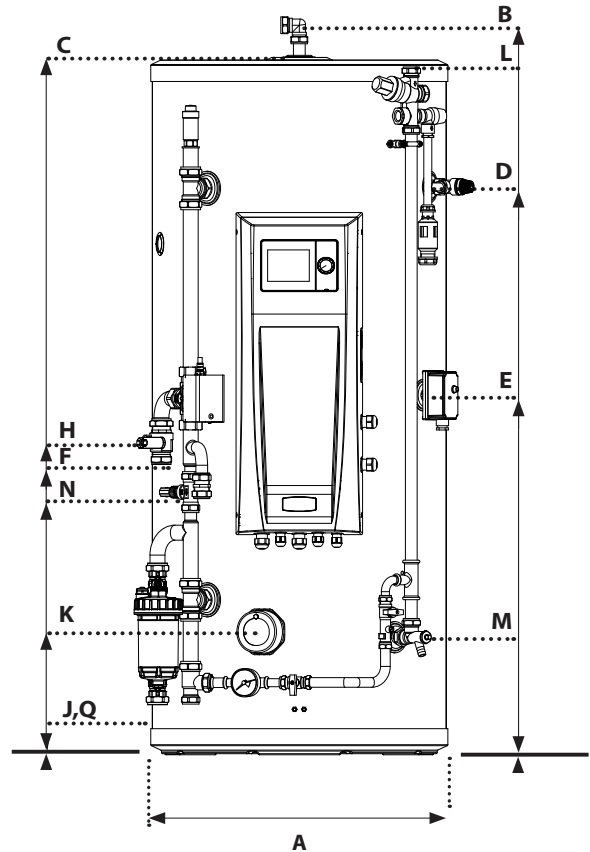

IDEPLUHP180PPSZ
PP Single Zone - 550 mm

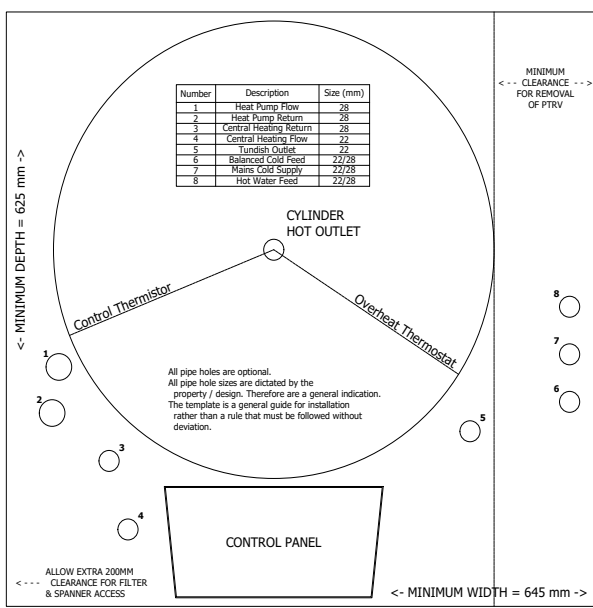

Plan View - PP Single Zone - 475 mm

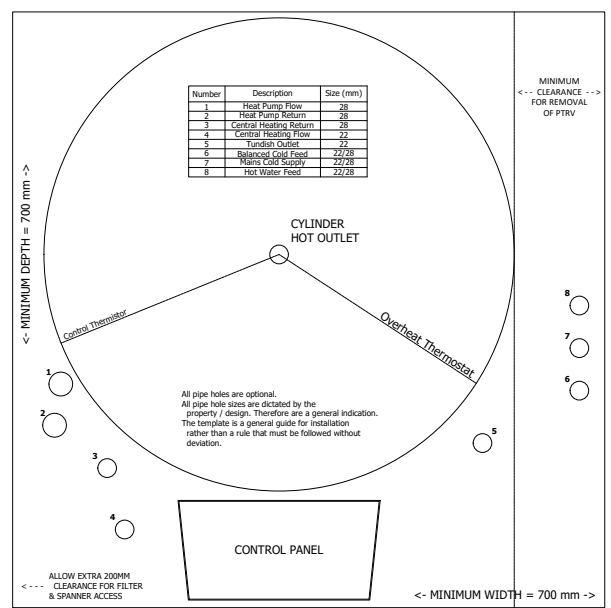

Plan View - PP Single Zone - 550 mm

DESIGN

Table 2 Logic Air Two Zone Preplumbed Cylinders

General Description		210, 250 & 300 litre; 475mm & 550mm diameter; single coil cylinders intended for coupling with a range of heat pumps 5kW to 14kW; Pre-plumbed and pre-wired including control box. Intended for a dual zone heating system installation. A low loss header is supplied fitted to decouple the heat pump from the heating zones.			
Assembly Model code/number		LOGIC AIR DHW CYL PP 210 CBOX LL 2Z SL	LOGIC AIR DHW CYL PP 210 CBOX LL 2Z	LOGIC AIR DHW CYL PP 250 CBOX LL 2Z	LOGIC AIR DHW CYL PP 300 CBOX LL 2Z
Cylinder model code/number		IDEPLUHP210PPDZSL	IDEPLUHP210PPDZ	IDEPLUHP250PPDZ	IDEPLUHP300PPDZ
Energy Efficiency Class		C	B	C	C
Heat Loss	Watts	65	55	63	72
	kWh/24h	1.55	1.33	1.52	1.74
Capacity (DHW content)	Litres	188	199	237	279
Volume heated by immersion heater	Litres	184	177	227	267
Weight Empty	kg	53.6	57	62.8	66.4
Weight Full	kg	241.9	255.8	345.4	345.4
Pressure Reducing valve setting	bar	3	3	3	3
Expansion relief valve setting	bar	4.5	4.5	4.5	4.5
Temperature setting of TPRV	°C	95	95	95	95
Pressure setting of TPRV	bar	6	6	6	6
Potable Expansion Vessel size.	Litres	24	24	24	35
Expansion Vessel charge	bar	3	3	3	3
Maximum horizontal dimension	mm	629	674	674	674
Maximum vertical dimension	mm	2039	1569	1819	2065
Overall Diameter	mm	A 475	A 550	A 550	A 550
DHW outlet	mm	B 2023	B 1553	B 1803	B 2049
Cylinder Height	mm	C 1963	C 1494	C 1744	C 1990
TPRV port	mm	D 1737	D 1252	D 1502	D 1748
Manual reset overheat thermostat pocket	mm	E 1151	E 1051	E 1150	E 1150
Primary flow	mm	F 647	F 647	F 647	F 647
Secondary return port	mm	G 1551	G 1141	G 1353	G 1562
Thermistor pocket	mm	H 816	H 687	H 769	H 823
Primary return	mm	J 61	J 61	J 61	J 61
Immersion heater pocket	mm	K 230	K 230	K 230	K 230
Cold water inlet	mm	L 1961	L 1475	L 1726	L 1971
Cylinder Drain	mm	M 220	M 220	M 220	M 220
CH1 Flow	mm	N 266	N 266	N 266	N 266
CH2 Flow (n/a to SZ version)	mm	P 156	P 156	P 156	P 156
CH Return	mm	Q 132	Q 132	Q 132	Q 132
Buffer Connections	mm	R -	R -	R -	R -
Buffer Inspection	mm	S -	S -	S -	S -
Buffer Drain	mm	T -	T -	T -	T -
Primary heat exchanger surface area	m ²	2.5	2.5	3.0	3.0
Primary heat exchanger capacity	Litres	10.6	10.6	10.6	10.6
Primary heat exchanger thermal rating ¹	kW	35.2 (19.9)	34.5 (16.1)	36.0 (18.0)	37.4 (19.0)
Primary heat exchanger pressure loss ¹	bar	0.047	0.047	0.042	0.050
Heat up time from 10°C to 60°C (50°C)	min	18.78 (23.68)	18.74 (30.60)	22.01 (27.34)	22.97 (35.05)
V40	Litres	306 (222)	303 (227)	373/276	406 (317)
Revision Level		D8.2	D8.2	D8.2	D8.2

Measured at 0.25 (0.42) l/s primary flow rate and at 80 (55)°C flow temperature, tested to BS EN 12897:2016, figures in brackets show figures for HWA 002:2020 heat pump test results

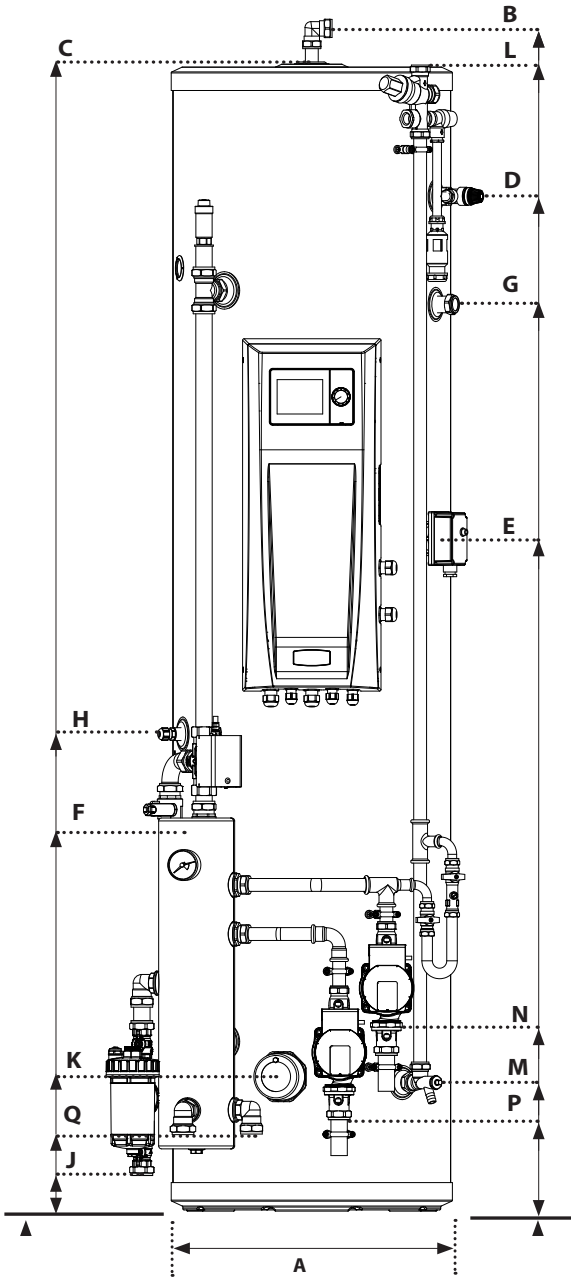

IDEPLUHP210PPDZSL
PP Double Zone - 475 mm

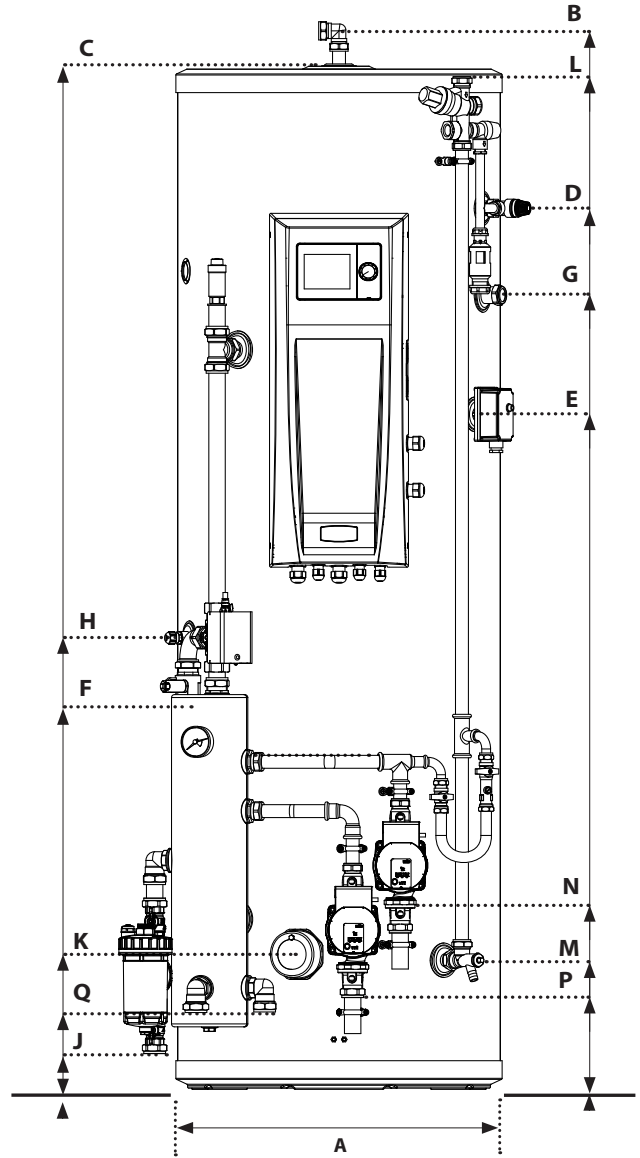

IDEPLUHP250PPDZ
PP Double Zone - 550 mm

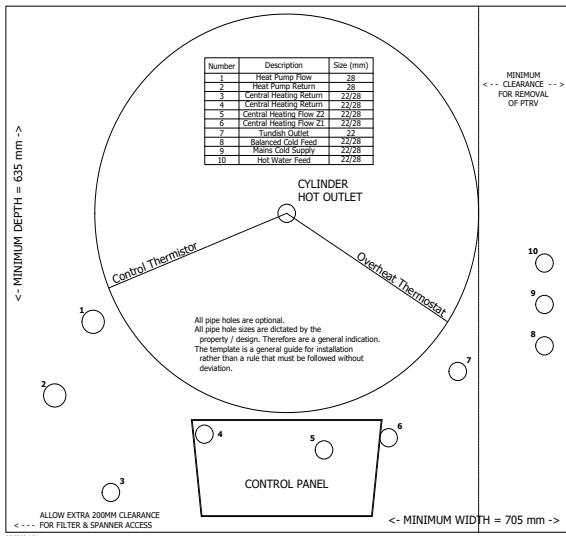

Plan View - PP Two Zone - 475 mm

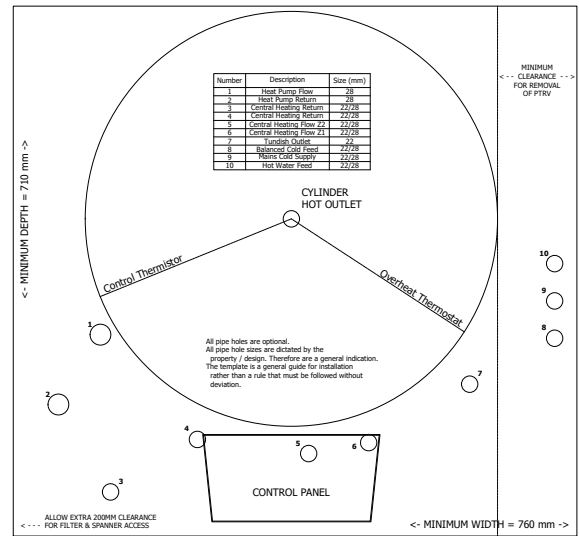

Plan View - PP Two Zone - 550 mm

DESIGN

Table 3 Logic Air Single Zone Preplumbed Buffer and Cylinder

General Description		180, 210, 250 & 300 litre; 550mm & 630mm diameter; single coil cylinders intended for coupling with a range of heat pumps 5kW to 14kW; Pre-plumbed and pre-wired including control box. Intended for a single zone heating system installation. These products incorporate a buffer which increases system volume and decouples the heat pump from the central heating zone. It is possible to upgrade this product to a dual zone at a later date.							
Assembly Model code/number		LOGIC AIR DHW CYL PP 180 CBOX BUFF 1Z		LOGIC AIR DHW CYL PP 210 CBOX BUFF 1Z		LOGIC AIR DHW CYL PP 250 CBOX BUFF 1Z		LOGIC AIR DHW CYL PP 300 CBOX BUFF 1Z	
Cylinder model code/number		IDEPLUHP180DUOPPSZ		IDEPLUHP210DUOPPSZ		IDEPLUHP250DUOPPSZ		IDEPLUHP300DUOPPSZ	
Energy Efficiency Class		B		B		B		B	
Heat Loss	Watts	49		55		62		68	
	kWh/24h	1.18		1.33		1.49		1.63	
Capacity (DHW content)	Litres	170		199		199		239	
Volume heated by immersion heater	Litres	158		189		218		267	
Weight Empty	kg	58/61		62/65		70/73		80/83	
Weight Full	kg	299/302		332/334		371/374		431/433	
Pressure Reducing valve setting	bar	3		3		3		3	
Expansion relief valve setting	bar	4.5		4.5		4.5		4.5	
Temperature setting of TPRV	°C	95		95		95		95	
Pressure setting of TPRV	bar	6		6		6		6	
Potable Expansion Vessel size.	Litres	18		24		24		35	
Expansion Vessel charge	bar	3		3		3		3	
Maximum horizontal dimension	mm	689		689		772		772	
Maximum vertical dimension	mm	1904		2092		1905		2125	
Overall Diameter	mm	A	550	A	550	A	630	A	630
DHW outlet	mm	B	1888	B	2076	B	1889	B	2109
Cylinder Height	mm	C	1829	C	2017	C	1829	C	2049
TPRV port	mm	D	1586	D	1774	D	1572	D	1792
Manual reset overheat thermostat pocket	mm	E	1151	E	1151	E	1151	E	1151
Primary flow	mm	F	742	F	742	F	742	F	742
Secondary return port	mm	G	-	G	1664	G	1491	G	1678
Thermistor pocket	mm	H	1109	H	1172	H	1101	H	1174
Primary return	mm	J	117	J	117	J	82	J	82
Immersion heater pocket	mm	K	744	K	744	K	736	K	736
Cold Water Inlet	mm	L	1810	L	2000	L	1796	L	2016
Cylinder Drain	mm	M	744	M	744	M	736	M	736
CH1 Flow	mm	N	118	N	118	N	83	N	83
CH2 Flow (n/a to SZ version)	mm	P	118	P	118	P	83	P	83
CH Return	mm	Q	118	Q	118	Q	83	Q	83
Buffer Connections	mm	R	375	R	375	R	340	R	340
Buffer Inspection	mm	S	360	S	360	S	325	S	325
Buffer Drain	mm	T	221	T	221	T	219	T	219
Primary heat exchanger surface area	m ²	2.5		2.5		2.5		3.0	
Primary heat exchanger capacity	Litres	8.5		10.6		8.5		10.6	
Primary heat exchanger thermal rating ¹	kW	35.1 (17.8)		37.2 (14.5)		37.0 (23.6)		39.2 (14.3)	
Primary heat exchanger pressure loss ¹	bar	0.082		0.048		0.047683333		0.042	
Heat up time from 10°C to 60°C (50°C)	min	14.52 (22.17)		16.36 (32.71)		20.29 (26.56)		21.77 (44.09)	
V40	Litres	241.5 (185.5)		288.4 (224.3)		354.5 (260.2)		402.2 (295.8)	
Revision Level		D8.2		D8.2		D8.2		D8.2	
V40	Litres	241.5 (185.5)		288.4 (224.3)		354.5 (260.2)		402.2 (295.8)	
Revision Level		D8.2		D8.2		D8.2		D8.2	

Measured at 0.25 (0.42) l/s primary flow rate and at 80 (55)°C flow temperature, tested to BS EN 12897 :2016, figures in brackets show figures for HWA 002:2020 heat pump test results

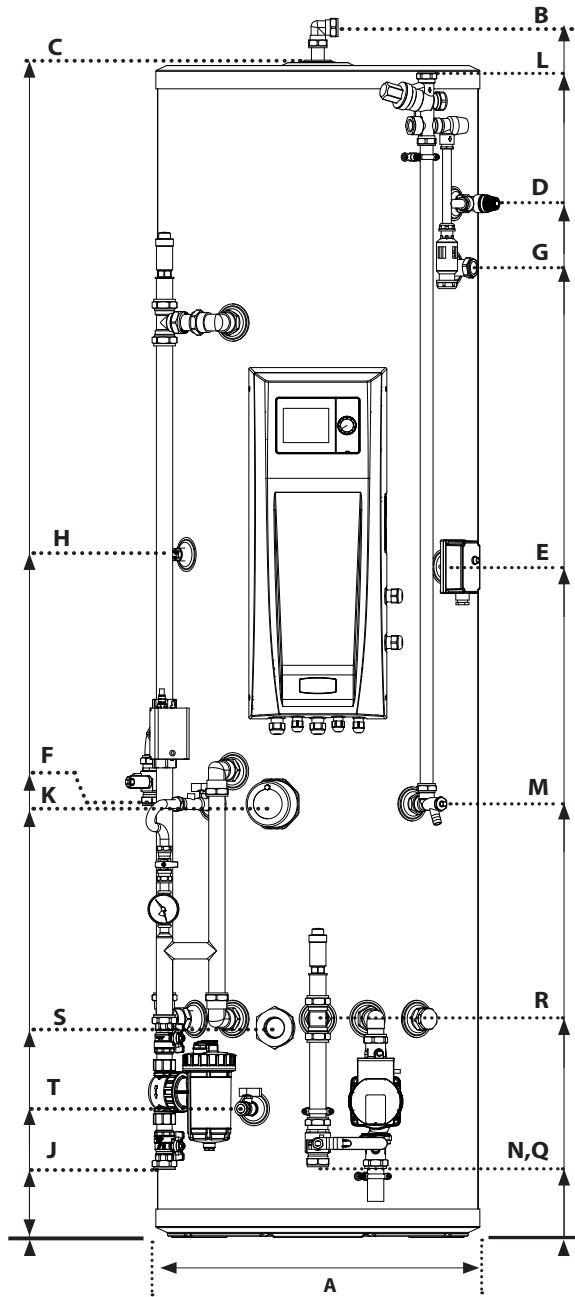

IDEPLUHP210DUOPPSZ - 550 mm

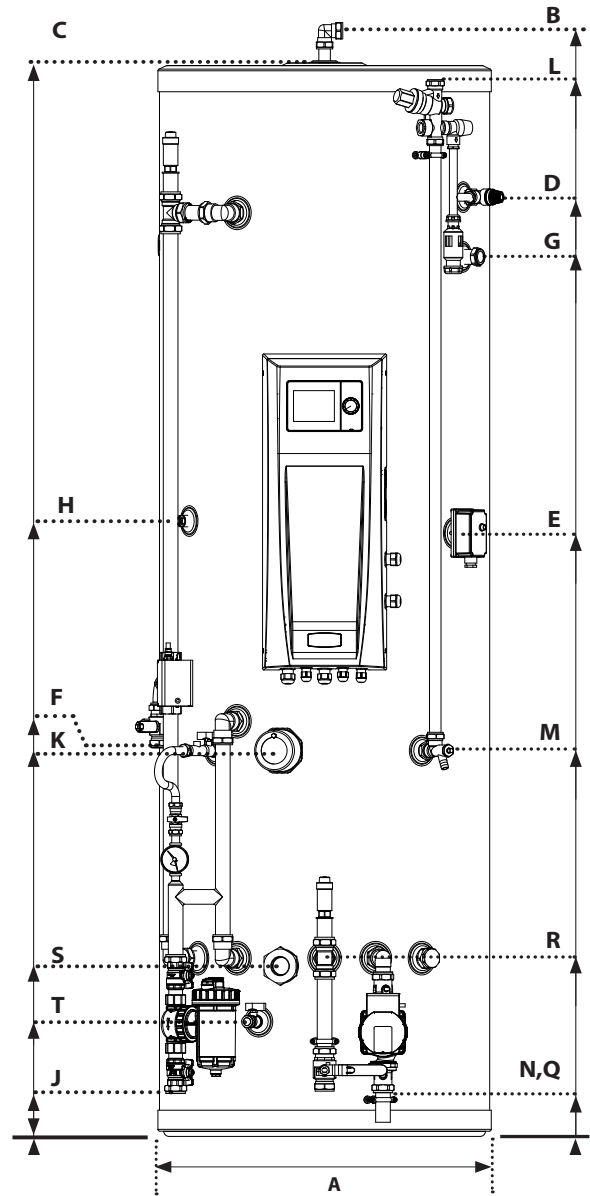

IDEPLUHP300DUOPPSZ - 630 mm

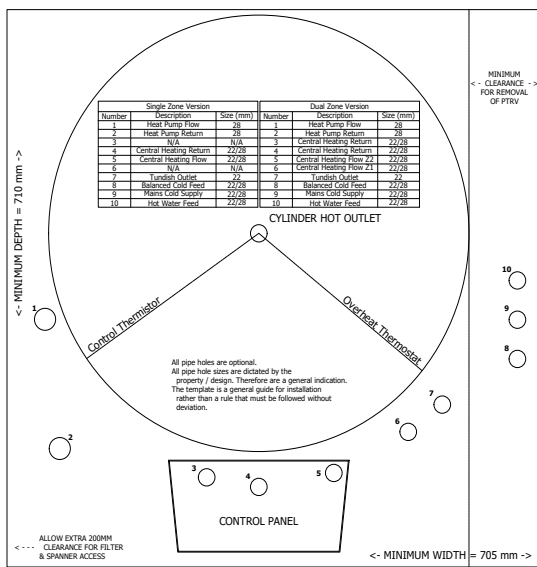

Plan View - PP Duo Single Zone - 550 mm

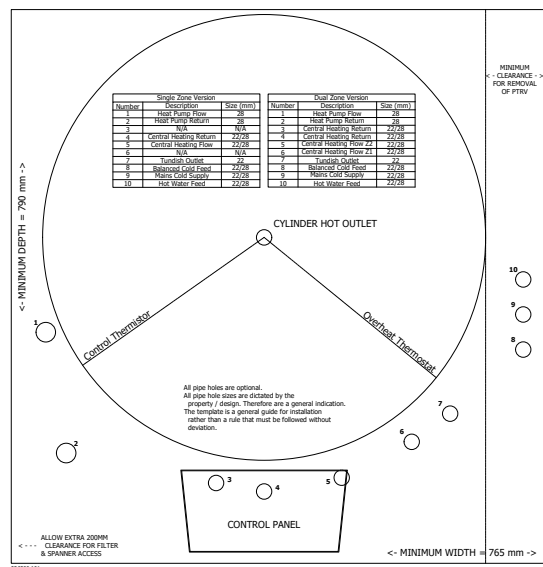

Plan View - PP Duo Single Zone - 630 mm

DESIGN

Table 4 Logic Air Two Zone Preplumbed Buffer and Cylinder

General Description		180, 210, 250 & 300 litre; 550mm & 630mm diameter; single coil cylinders intended for coupling with a range of heat pumps 5kW to 14kW; Pre-plumbed and pre-wired including control box. Intended for a dual zone heating system installation. These products incorporate a buffer which increases system volume and decouples the heat pump from the central heating zones.					
Assembly Model code/number		LOGIC AIR DHW CYL PP 180 CBOX BUFF ZZ	LOGIC AIR DHW CYL PP 210 CBOX BUFF ZZ	LOGIC AIR DHW CYL PP 250 CBOX BUFF ZZ	LOGIC AIR DHW CYL PP 300 CBOX BUFF ZZ		
Cylinder model code/number		IDEPLUHP180DUOPPDZ	IDEPLUHP210DUOPPDZ	IDEPLUHP250DUOPPDZ	IDEPLUHP300DUOPPDZ		
Energy Efficiency Class		B	B	B	B		
Heat Loss	Watts	49	55	62	68		
	kWh/24h	1.18	1.33	1.49	1.63		
Capacity (DHW content)	Litres	170	199	199	239		
Volume heated by immersion heater	Litres	158	189	218	267		
Weight Empty	kg	58/61	62/65	70/73	80/83		
Weight Full	kg	299/302	332/334	371/374	431/433		
Pressure Reducing valve setting	bar	3	3	3	3		
Expansion relief valve setting	bar	4.5	4.5	4.5	4.5		
Temperature setting of TPRV	°C	95	95	95	95		
Pressure setting of TPRV	bar	6	6	6	6		
Potable Expansion Vessel size.	Litres	18	24	24	35		
Expansion Vessel charge	bar	3	3	3	3		
Maximum horizontal dimension	mm	689	689	772	772		
Maximum vertical dimension	mm	1904	2092	1905	2125		
Overall Diameter	mm	A 550	A 550	A 630	A 630		
DHW outlet	mm	B 1888	B 2076	B 1889	B 2109		
Cylinder Height	mm	C 1829	C 2017	C 1829	C 2049		
TPRV port	mm	D 1586	D 1774	D 1572	D 1792		
Manual reset overheat thermostat pocket	mm	E 1151	E 1151	E 1151	E 1151		
Primary flow	mm	F 742	F 742	F 742	F 742		
Secondary return port	mm	G -	G 1664	G 1491	G 1678		
Thermistor pocket	mm	H 1109	H 1172	H 1101	H 1174		
Primary return	mm	J 117	J 117	J 82	J 82		
Immersion heater pocket	mm	K 744	K 744	K 736	K 736		
Cold Water Inlet	mm	L 1810	L 2000	L 1796	L 2016		
Cylinder Drain	mm	M 744	M 744	M 736	M 736		
CH1 Flow	mm	N 118	N 118	N 83	N 83		
CH2 Flow (n/a to SZ version)	mm	P 118	P 118	P 83	P 83		
CH Return	mm	Q 118	Q 118	Q 83	Q 83		
Buffer Connections	mm	R 375	R 375	R 340	R 340		
Buffer Inspection	mm	S 360	S 360	S 325	S 325		
Buffer Drain	mm	T 221	T 221	T 219	T 219		
Primary heat exchanger surface area	m ²	2.5	2.5	2.5	3.0		
Primary heat exchanger capacity	Litres	8.5	10.6	8.5	10.6		
Primary heat exchanger thermal rating ¹	kW	35.1 (17.8)	37.2 (14.5)	37.0 (23.6)	39.2 (14.3)		
Primary heat exchanger pressure loss ¹	bar	0.082	0.048	0.047683333	0.042		
Heat up time from 10°C to 60°C (50°C)	min	14.52 (22.17)	16.36 (32.71)	20.29 (26.56)	21.77 (44.09)		
V40	Litres	241.5 (185.5)	288.4 (224.3)	354.5 (260.2)	402.2 (295.8)		
Revision Level		D8.2	D8.2	D8.2	D8.2		
V40	Litres	241.5 (185.5)	288.4 (224.3)	354.5 (260.2)	402.2 (295.8)		
Revision Level		D8.2	D8.2	D8.2	D8.2		

Measured at 0.25 (0.42) l/s primary flow rate and at 80 (55)°C flow temperature, tested to BS EN 12897 :2016, figures in brackets show figures for HWA 002:2020 heat pump test results

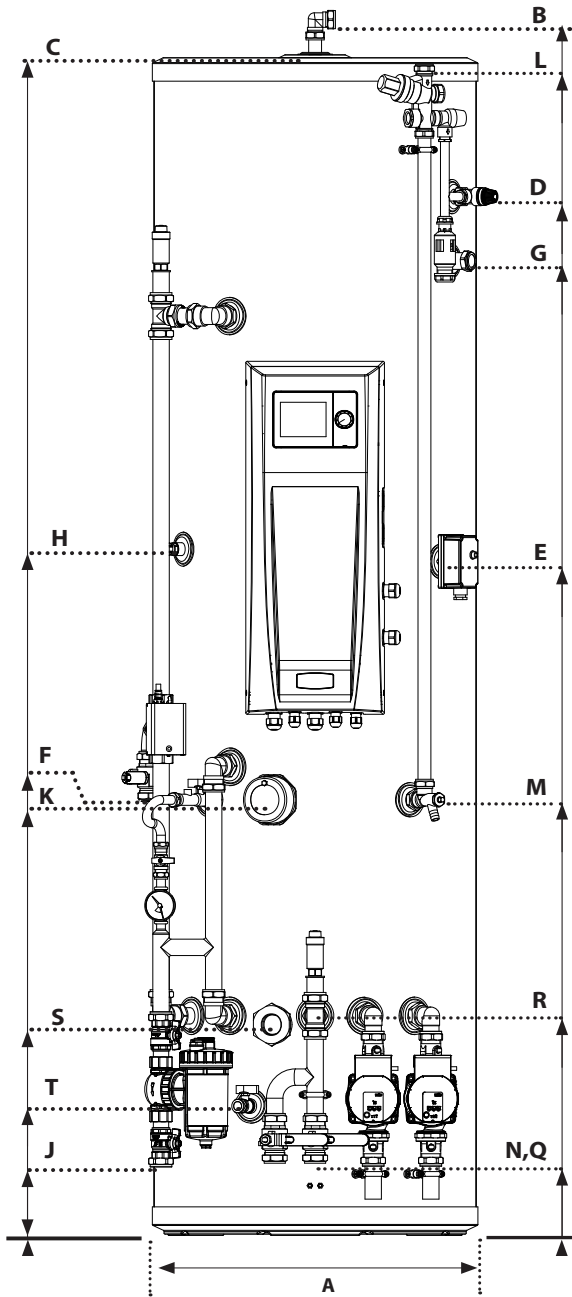

IDEPLUHP210DUOPPDZ - 550 mm

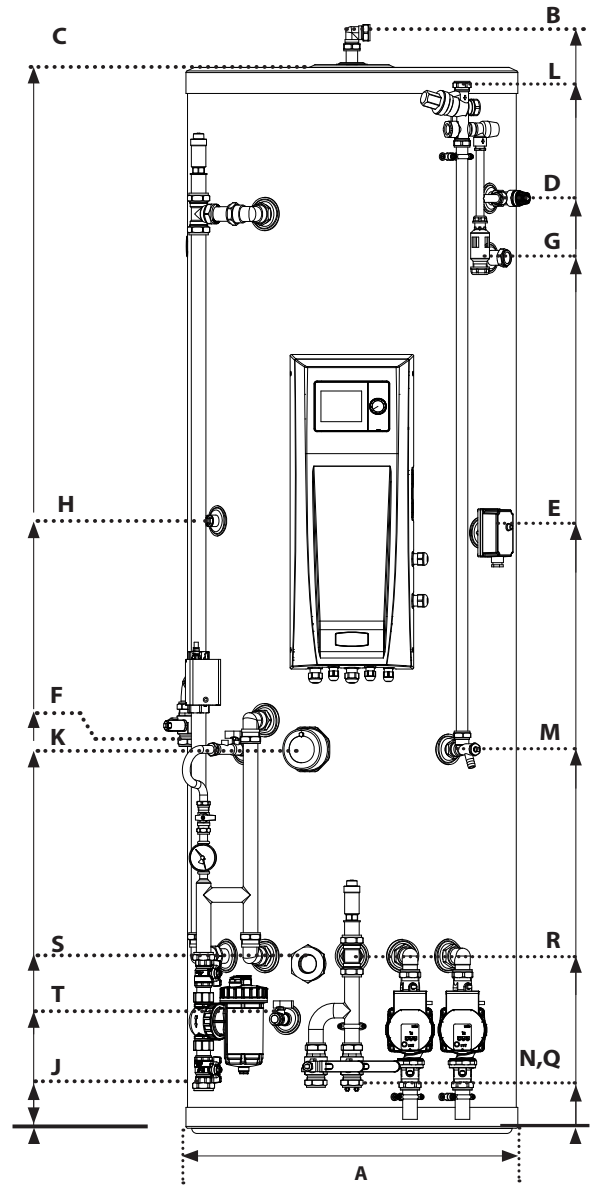

IDEPLUHP300DUOPPDZZ - 630 mm

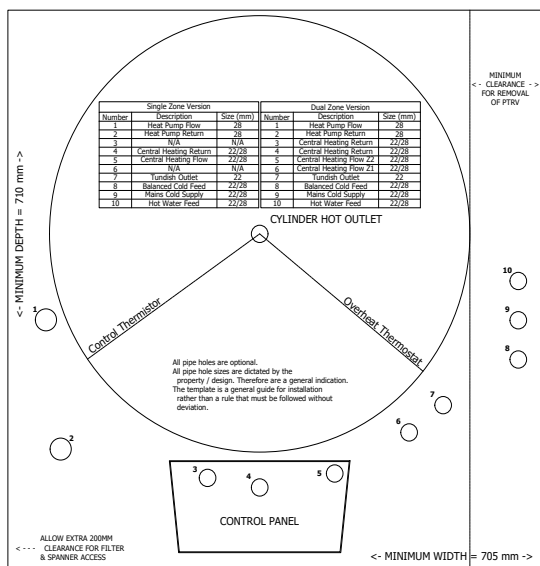

Plan View - PP Duo DZ - 550 mm

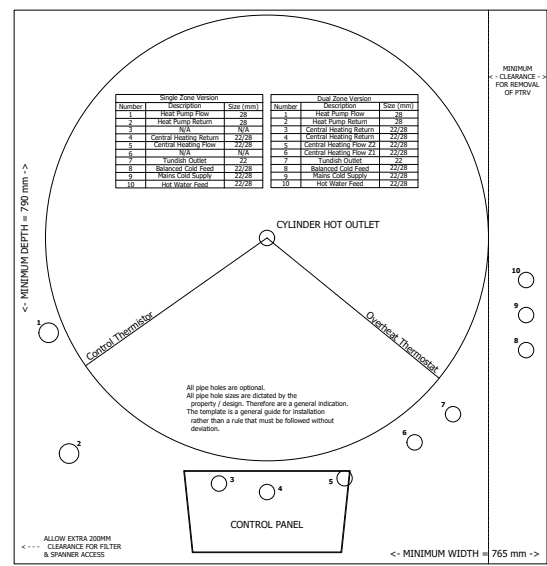

Plan View - PP Duo DZ - 630 mm

DESIGN

Table 5 Logic Air Single 400 litre cylinder and 90 litre buffer

General Description		400 litre; 630mm diameter; single coil cylinders intended for coupling with heat pumps and a separate 90 litre; 550mm diameter buffer with 8 flow connections, 8 return connections 2 sensor pockets, a vent port an inspection hatch and a drain port			
Assembly Model code/number		LOGIC AIR DHW CYL 400		Assembly Model code/number	
Cylinder model code/number		IDEPLUHP400		Cylinder model code/number	
Energy Efficiency Class		C		Energy Efficiency Class	
Heat Loss	Watts	80		Heat Loss	Watts
	kWh/24h	1.91			kWh/24h
Capacity (DHW content)	Litres	381		Capacity (Primary content)	Litres
Volume heated by immersion heater	Litres	372			
Weight Empty	kg	62		Weight Empty	kg
Weight Full	kg	462		Weight Full	kg
Pressure Reducing valve setting	bar	3			
Expansion relief valve setting	bar	4.5		Maximum working pressure	Bar
Temperature setting of TPRV	°C	95			
Pressure setting of TPRV	bar	6			
Expansion Vessel size.	Litres	2 x 24			
Expansion Vessel charge	bar	3			
Maximum horizontal dimension	mm	636		Maximum horizontal dimension	mm
Maximum vertical dimension	mm	2065		Maximum vertical dimension	mm
Overall Diameter	mm	A	630	Overall Diameter	mm
DHW outlet	mm	B	2040	Vent/relief boss (22mm pipe)	mm
Cylinder Height	mm	C	1982	Cylinder Height	mm
TPRV port	mm	D	1726	Upper thermostat pocket	mm
Manual reset overhear thermostat pocket	mm	E	1726	Upper 28mm tapings Height	mm
Primary flow	mm	F	1660	Inspection hatch pocket (1 3/4" BSP)	mm
Secondary return port	mm	G	1543	Lower 28mm tapings Height	mm
Thermistor pocket	mm	H	844	Lower thermostat pocket	mm
Primary return	mm	J	330	Drain (1/2" BSP)	mm
Cold water inlet	mm	K	260		
Immersion heater pocket	mm	L	220		
Primary heat exchanger surface area	m2	4.0			
Primary heat exchanger capacity	Litres	14.1			
Primary heat exchanger thermal rating1	kW	41.9(24.7)			
Primary heat exchanger pressure loss1	bar	0.052			
Heat up time from 10°C to 60°C (50°C)	min	27.8 (37.48)			
V40	Litres	550.5 (444)			
Revision Level		D8.2		Revision Level	P3.0

Measured at 0.25 (0.42) l/s primary flow rate and at 80 (55)°C flow temperature, tested to BS EN 12897:2016, figures in brackets show figures for HWA 002:2020 heat pump test results

Plain HP Cylinder - 630 mm

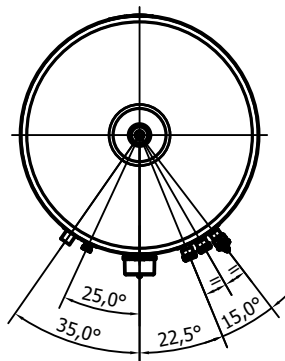

Plain FLX Buffer - 550 mm

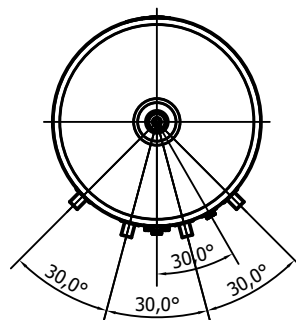

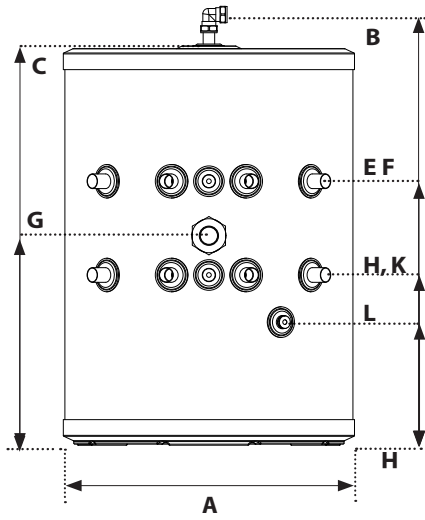

IDEPLU090MB
Plain FLX Buffer - 550 mm

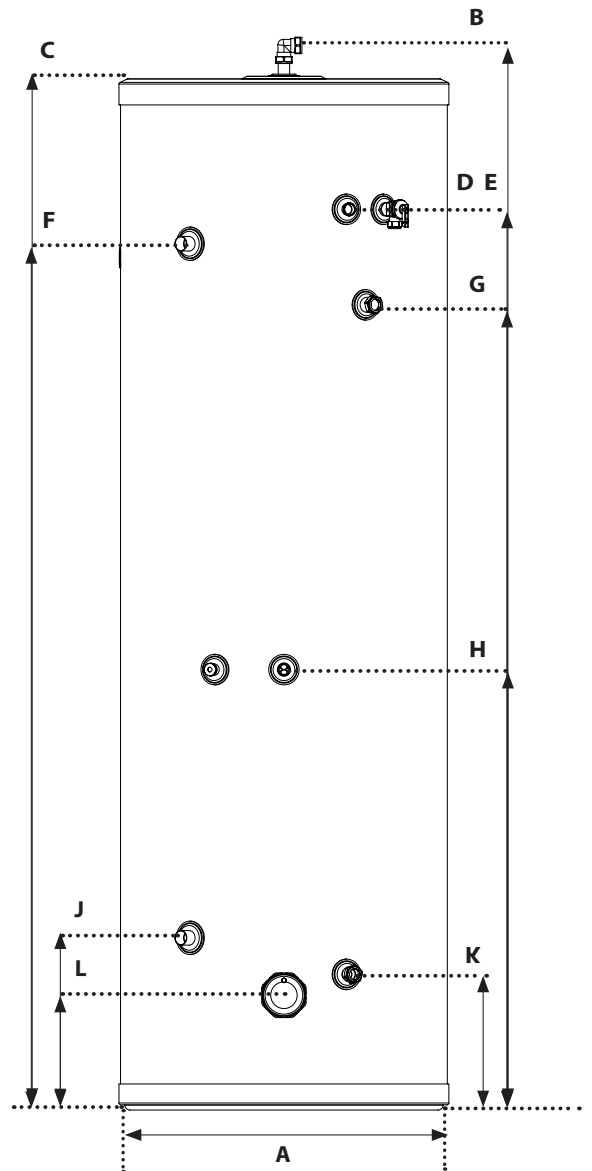

IDEPLUHP400
Plain HP Cylinder - 630 mm

DESIGN

Logic Air Single zone Preplumbed cylinders tapping

Description

1. Hot water draw off
2. 22mm cold supply
3. Combination inlet group
4. Pressure & temperature relief valve
5. Tundish
6. Overheat Thermostat
7. Cold feed assembly
8. Immersion heater
9. Drain valve
10. Filling loop
11. Pressure gauge
12. Central heating return
13. Heat pump return
14. Filter
15. Central heating flow
16. Auto bypass
17. Heatpump flow
18. 3 port valve
29. Auto air vent
20. Control Panel

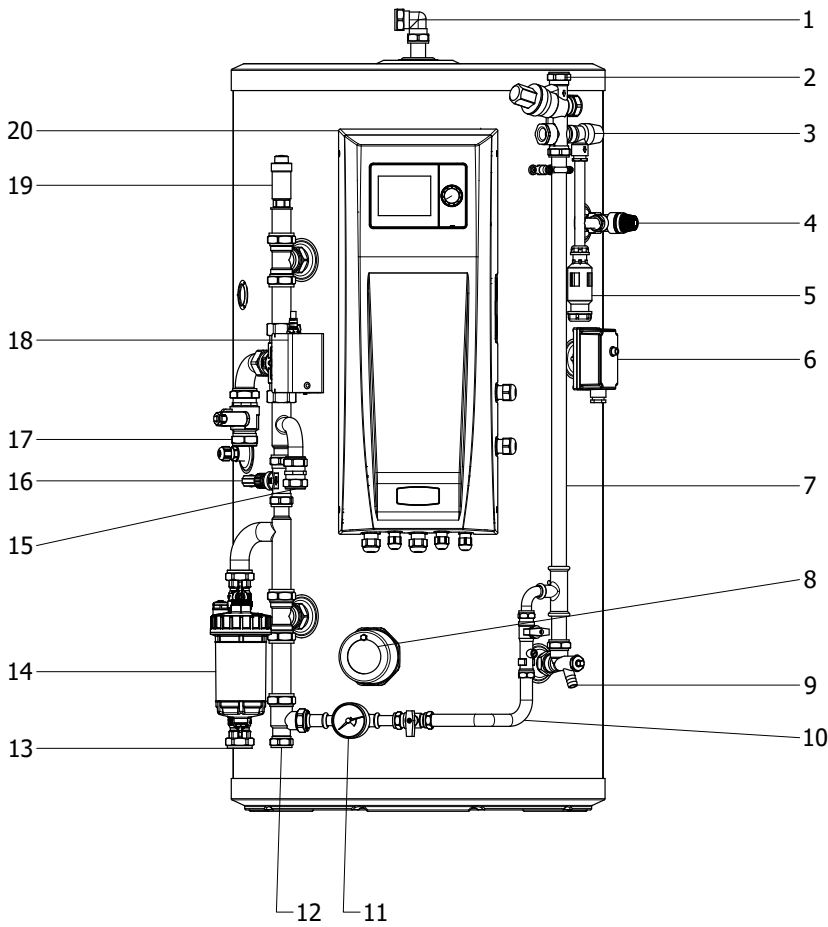

IDEPLUHP150PPSZ
PP Single Zone - 475 mm

SINGLE ZONE

Ideal Heating Logic Air Pre-plumbed Cylinders are a range of unvented hot water storage cylinders, manufactured in the latest high quality duplex stainless steel. They are designed to provide mains pressure hot water and are supplied as a package which complies with Section G3 of the Building Regulations. The appliance is extremely well insulated using high density HCFC free foam insulation with an ozone depleting potential (ODP) of zero and a global warming potential (GWP) of 2. It is fitted with all necessary safety devices pre-plumbed and pre-wired to enable the simplest installation possible. (the 400 litre version is not pre-plumbed).

SINGLE ZONE

Logic Air single zone Pre-plumbed cylinders:

The Logic Air Single Zone Pre-Plumbed Cylinder is an unvented hot water storage cylinder fitted with the necessary plumbing components to run a single zone heating system. It is expected that the primary circulating pump in the heat pump will be sufficient to overcome the pressure losses in the central heating and maintain the required flow speeds, so no addition pump is supplied.

A three port full divert zone vale is incorporated to control the energy flow to the cylinder or to the central heating. An auto by pass valve is fitted to maintain a minimum flow to the heat pump as TRV's close. A magnet and fine mesh filter are fitted in the return flow to protect and prolong the heat pump's service life.

A filling loop and pressure gauge are supplied to enable easy system pressure top up by the householder. Discharge from any system expansion relief valve can be plumbed into DHW system discharge manifold. In addition an auto air vent is fitted to the highest point on the primary pipework.

The Single zone Pre-Plumbed Cylinder includes a 3 kW (230 Vac, 50 Hz) immersion heater which is wired to the controls box relay. The relay supplied needs to be wired back to as local isolation point. The system controls will be programmed to bring the immersion heater on to inhibit Legionella growth, boost the heat pumps performance, and as a back up heat source.

The immersion heater incorporates its own thermostat and overheat thermostat. The thermostat is set to maximum circa 68°C but the control system uses the cylinder's thermistor to control the DHW temperature. In addition, to the thermistor a separate overheat thermostat is wired to the control box. The technical details of the single zone models are listed in table 1.

DESIGN

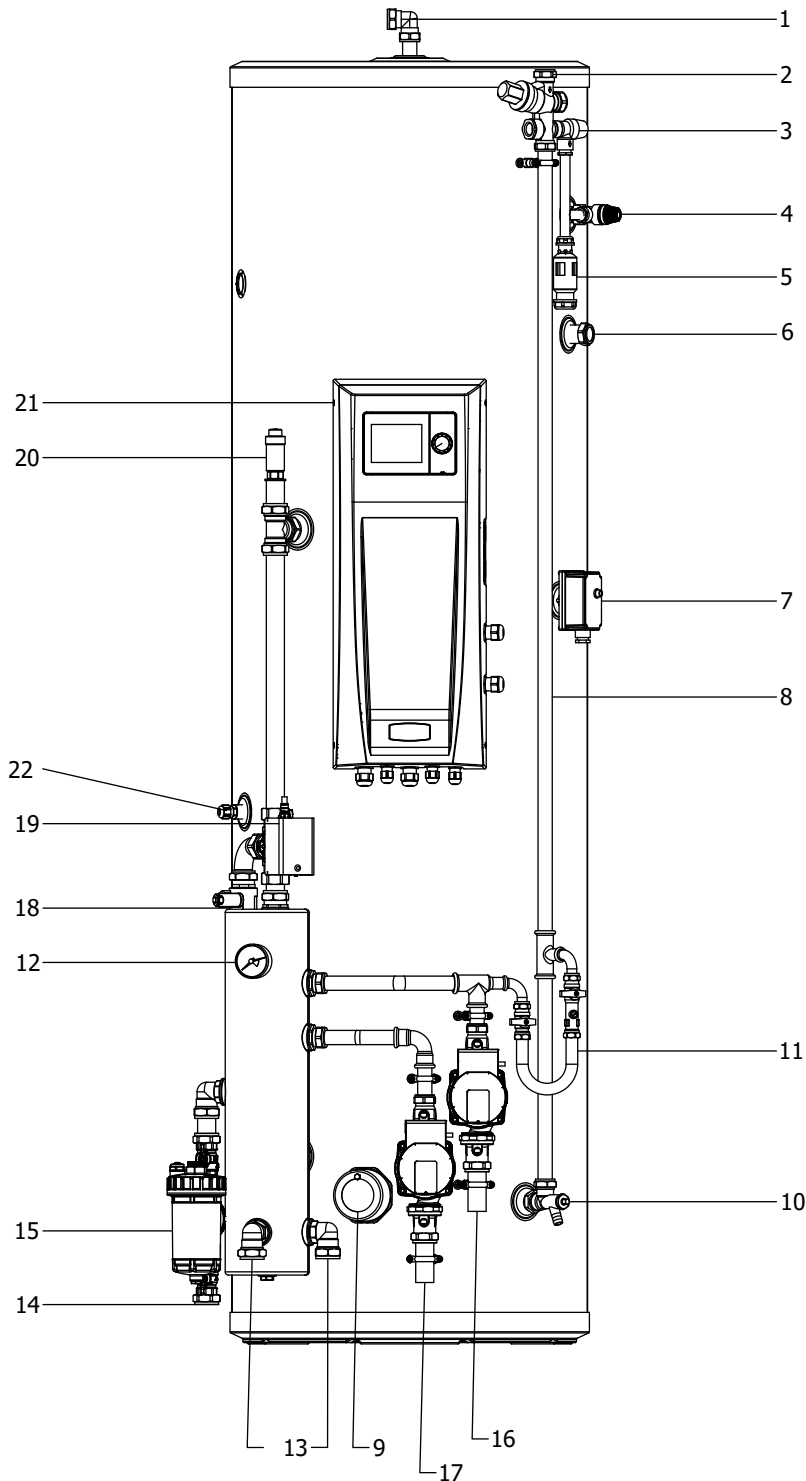

Logic Air Two Zone Preplumbed Cylinders

Description

1. Hot water draw off
2. 22mm cold supply
3. Combination inlet group
4. Pressure & temperature relief valve
5. Tundish
6. Secondary Return
7. Overheat Thermostat
8. Cold feed assembly
9. Immersion heater
10. Drain valve
11. Filling Loop
12. Pressure gauge
13. Central heating returns
14. Heatpump return
15. Filter
16. Central heating flow - zone 1
17. Central heating flow - zone 2
18. Heat pump flow
19. 3 port valve
20. Auto air vent
21. Control Panel
22. Control Thermostat connection

IDEPLUHP300PPDZ
PP Double Zone - 550 mm

TWO ZONE

Logic Air Low Loss Header Pre-Plumbed Cylinder

The Logic Air Low loss header Pre-Plumbed Cylinder is an unvented hot water storage cylinder fitted with the necessary plumbing components to run a two zone heating system. The primary circulating pump in the heat pump is plumbed to the cylinder coil and the low loss header. Flow is directed to either the coil or the low loss header by the three port full divert valve. The motor of this valve needs to be powered to enable heat to be supplied to the cylinder coil.

The return path from the low loss header incorporates a magnet and fine mesh filter to protect and prolong the heat pump's service life. No auto by pass valve is required in this system due to the hydraulic separation provided by the low loss header. The two heating zones are supplied with their own pump, no zone valves are required.

The heating zone return connections are side by side at the base of the low loss header. The upper zone has a filling loop connection and the low loss header has a pressure gauge to enable easy system pressure top up by the householder. Discharge from any system expansion relief valve can be plumbed into DHW system discharge manifold. In addition an auto air vent is fitted to the highest point on the primary pipework.

The Logic Air Low loss header Pre-Plumbed Cylinder includes a 3 kW (230Vac, 50Hz) immersion heater which is wired to the controls box relay. The relay supplied needs to be wired back to a local isolation point. The system controls will be programmed to bring the immersion heater on to inhibit Legionella growth, boost the heat pumps performance, and as a back up heat source. The immersion heater incorporates its own thermostat and overheat thermostat. The thermostat is set to maximum circa 68°C but the control system uses the cylinder's thermistor to control the DHW temperature. In addition, to the thermistor a separate overheat thermostat is wired to the control box. The product dimensions capacities and performance details of the Low loss header models are listed in table 2.

DESIGN

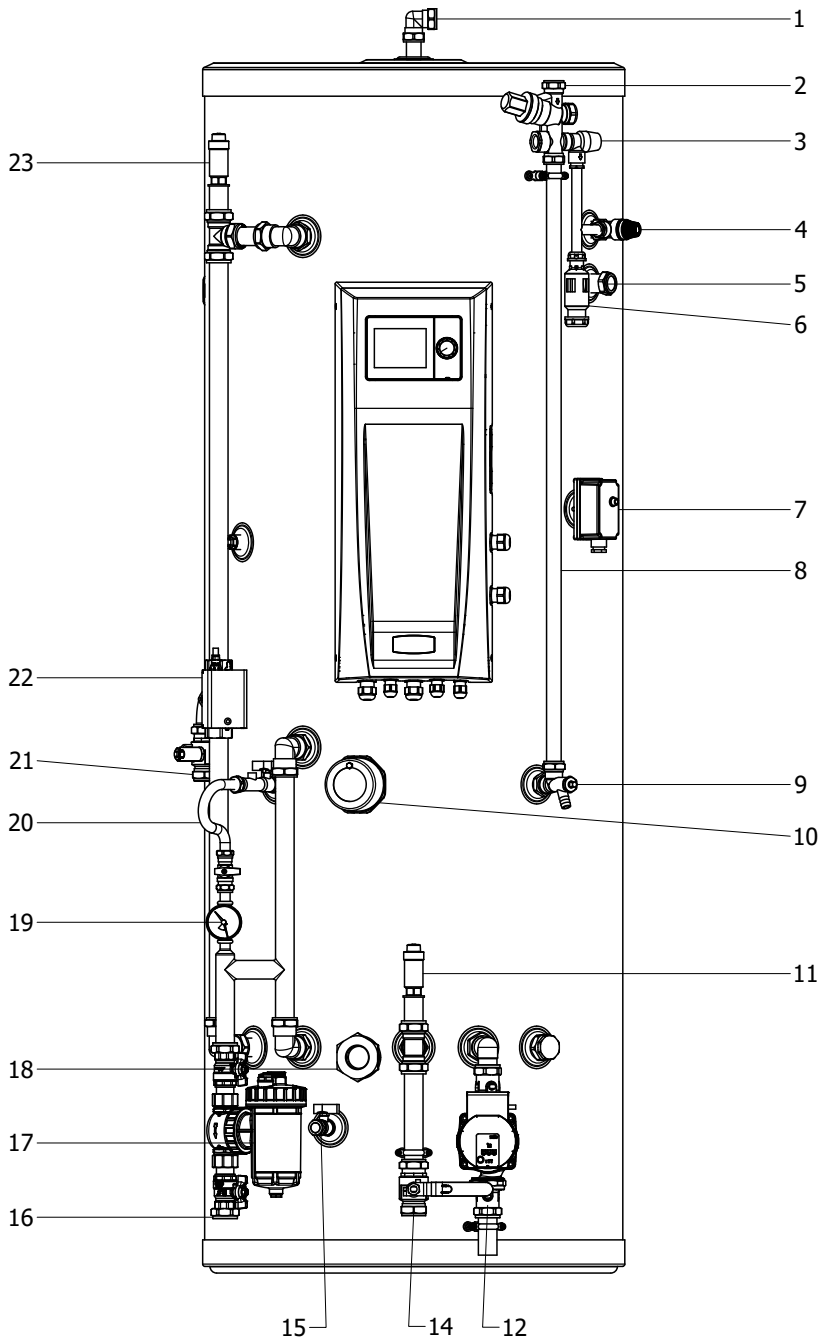

Logic Air Single Zone & Two Zone Preplumbed Buffer and Cylinder Duo

Description

1. Hot water draw off
2. 22 mm cold supply
3. Combination inlet group
4. Pressure & temperature relief valve
5. Secondary return
6. Tundish
7. Overheat Thermostat
8. Cold feed assembly
9. Drain valve
10. Immersion heater
11. Buffer auto air vent
12. Central heating flow - zone 1
13. Central heating flow - zone 2
14. Central heating returns
15. Buffer drain valve
16. Heatpump return
17. Filter
18. Buffer Inspection Hatch
19. Pressure gauge
20. Filling loop
21. Heatpump flow
22. 3 port valve
23. Auto air vent
24. Control Panel

IDEPLUHP250PPDZ
PP Duo Single Zone - 630mm

DUO SINGLE AND TWIN ZONE

Logic Air Pre-Plumbed Cylinder and Buffer Duo:

The Logic Air Pre-Plumbed Cylinder and Buffer Duo is an unvented hot water storage cylinder and primary system buffer combined into one cylinder case. The primary circulating pump in the heat pump is plumbed to the cylinder coil and the buffer via the three port full divert valve. The motor of this valve needs to be powered to enable heat to be supplied to the cylinder coil, therefore it works with the overheat thermostat as an energy cutoff. The return path from the buffer incorporates a magnet and fine mesh filter to protect and prolong the heat pump's service life. No auto bypass valve is required on this system due to the hydraulic separation provided by the buffer. The two heating zones are supplied from the buffer with their own pumps, no zone valves are required.

The heating zone return connections are joined and fed back to the buffer and air is removed from the system via the auto air valve at the top of this mini header. The return from the coil is plumbed to the return to the heat pump and this pipe incorporates a filling loop connection and pressure gauge to enable easy system pressure top up by the householder. Discharge from any system expansion relief valve can be plumbed into DHW system discharge manifold. In addition an auto air vent is fitted to the highest point on the primary pipework.

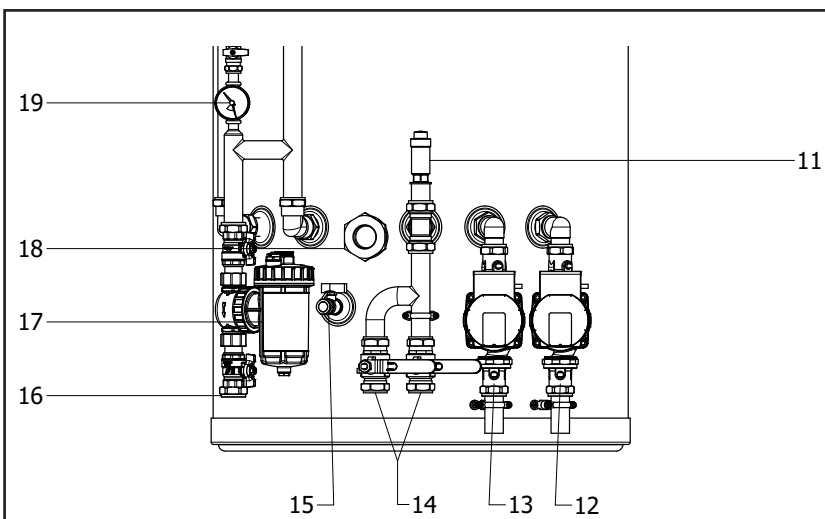

IDEPLUHP250DUOPPDZ
PP Duo Double Zone

DESIGN

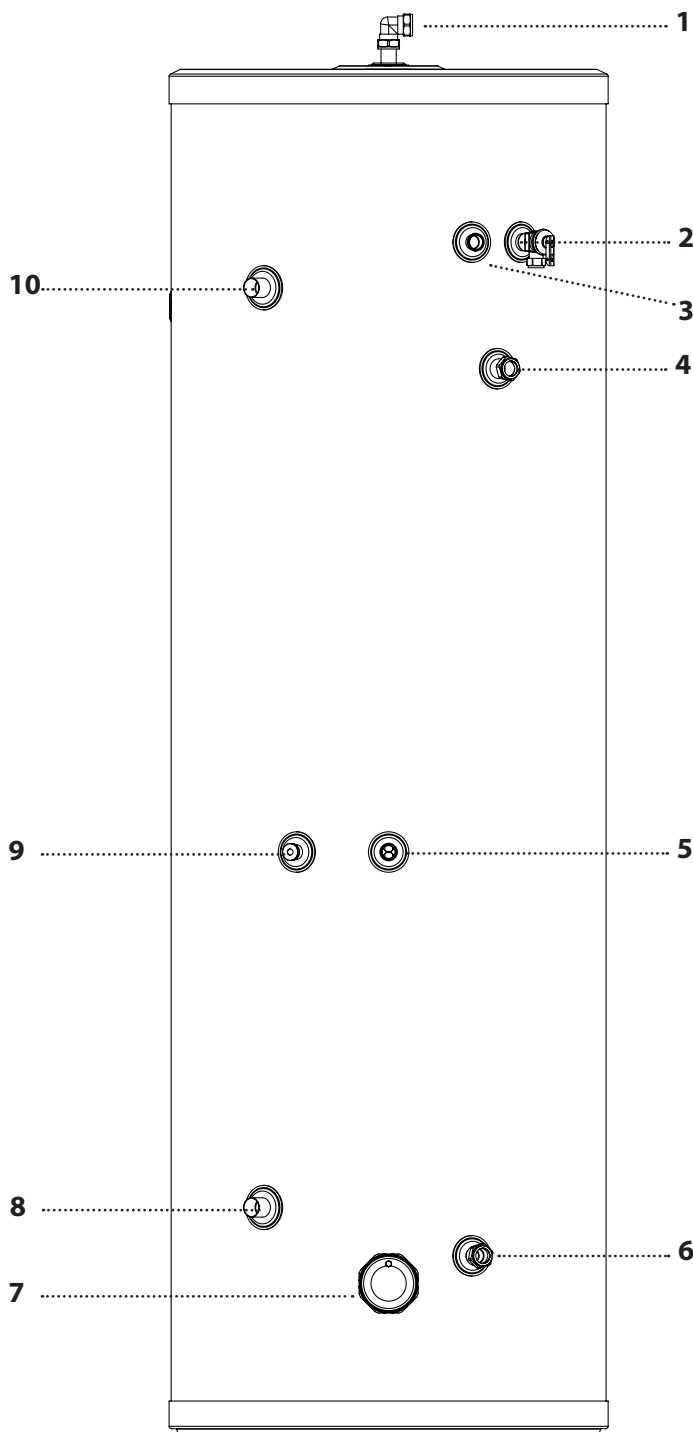

Logic Air Single 400 Litre Cylinder

Description

1. Hot water draw off
2. Pressure & temperature relief valve
3. Overheat thermostat
4. Secondary return
5. Control thermostat
6. 22 mm cold supply
7. Immersion heater
8. Heatpump return
9. Control thermostat
10. Heatpump flow

IDEPLUHP400
Plain HP Cylinder - 630 mm

CYLINDER AND BUFFER COMBINATION

Separate cylinder and buffer

The largest Heat pump cylinder in our range, the 400 litre is supplied without being pre-plumbed. It is expected that this product will be purchased with our 90 liter buffer product. This enables up to 3 zones to be supplied from the buffer. It is has been left to the installer to chose the equipment supplied with the product.

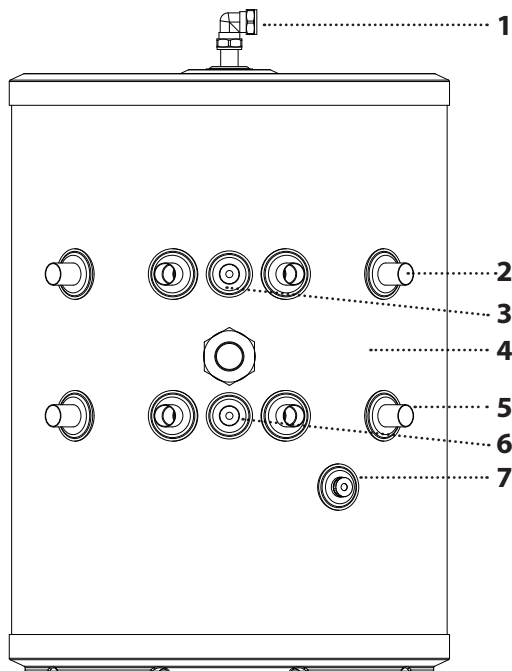

Logic Air Single 90 Litre Buffer

Description

1. Vent Connection
2. Upper flexible connections x 4
3. Upper control thermostat
4. Inspection hatch
5. Lower flexible connections x 4
6. Lower control thermostat
7. Drain

IDEPLU090MB
Plain FLX Buffer - 550 mm

HEAT PUMP CYLINDER SELECTION GUIDE

Beds (1-5)	People (1-10)	Baths (1-3)	Zones (1-2)	Cylinder size (based upon 55°C store temp)			Duo required for System volume	
				4.0 kW	5 kW	8 kW	10 kW	14 kW
1	1	1	1	HP150PPSZ	HP150PPSZ	HP150PPSZ	HP180DUOPP	HP180DUOPP
1	2	1	1	HP150PPSZ	HP150PPSZ	HP150PPSZ	HP180DUOPP	HP180DUOPP
assumptions: that 1 bed has a maximum of 2 people, has a maximum of 1 bath, has a maximum of 1 zone								
2	2	1	2	HP150PPDZ	HP150PPDZ	HP150PPDZ	HP180DUOPP	HP180DUOPP
2	3	1	2	HP210PPDZ	HP210PPDZ	HP210PPDZ	HP180DUOPP	HP180DUOPP
2	2	2	2	HP180PPDZ	HP180PPDZ	HP180PPDZ	HP180DUOPP	HP180DUOPP
2	3	2	2	HP210PPDZ	HP210PPDZ	HP210PPDZ	HP180DUOPP	HP180DUOPP
assumptions: that 2 bed has a minimum of 2 people, has a maximum of 4 people, has a maximum of 2 baths								
3	3	1	2	HP210PPDZ	HP210PPDZ	HP210PPDZ	HP210DUOPP	HP210DUOPP
3	3	2	2	HP210PPDZ	HP210PPDZ	HP210PPDZ	HP210DUOPP	HP210DUOPP
assumptions: that 3 bed has a minimum of 3 people, has a maximum of 6 people, has a maximum of 2 baths								
4	4	1	2		HP300PPDZ	HP300PPDZ	HP210DUOPP	HP210DUOPP
4	4	2	2		HP300PPDZ	HP300PPDZ	HP210DUOPP	HP210DUOPP
assumptions: that 4 bed has a minimum of 4 people, has a maximum of 8 people, has a maximum of 3 baths								
5	6	2	2			HP400	HP400	HP400
5	6	3	2			HP400	HP400	HP400
5	7	3	2				HP400	HP400
5	8	3	2				HP400	HP400
assumptions: that 5 bed has a minimum of 6 people, has a maximum of 8 people, has a minimum of 2 baths, has a maximum of 3 baths								

Model Selection

The suggested model sizes shown in the table above are based on a typical daily hot water usage and on the assumption that the heat pump will heat the domestic hot water to about 50°C. For higher specification, an increase of one model size should be considered.

When sizing the hot water cylinder, please use MCS guidelines in MIS3005 and also refer to BS EN 806:1-5 AND BS EN 8558.

WARNINGS AND CAUTIONS

WARNING 1 - Uncontrolled heat sources

Logic Air Heat Pump models must not be used with uncontrolled heat source or steam as the heat source.

WARNING 2 - Water sterilization

The DHW temperature setting selected is likely to be less than 60°C. When this is the case please ensure that the Heat pump control system is set to heat the water above 60°C on a regular basis.

WARNING 3 - Back-syphonage risk

An ascending spray type bidet or any other appliance with a fluid category 5 back-syphonage risk requiring a type A air gap should not be used.

WARNING 4 - Maintenance

Logic air should not be used in a situation where maintenance is likely to be neglected.

WARNING 5 - Solid fuel heat sources

Unvented cylinders are not suitable for direct connection to solid fuel boilers.

CAUTION 1 - Heat source compatibility with system type

All Logic Air Heat Pump models are suitable for both open vented and sealed primary systems. The minimum pump heads and the minimum operating pressure of the heat pump should be reviewed.

CAUTION 2 - Overheat thermostat

When used with a sealed primary heating system, the heat pump must incorporate its own over heat thermostat.

CAUTION 3 - Drain down procedure

A drain point is part of the cold feed elbow which is fitted to all products except the 400 model, where this is supplied in the kit. Follow drain down procedure on page 27.

CAUTION 4 - Mixer taps

If the supply to the mixer fittings (other than a dual outlet type) is not taken from the balanced supply the system will become over pressurized and cause the pressure relief valve to discharge. Over time this could also cause the premature failure of the appliance itself which will not be covered by the warranty.

CAUTION 5 - Suitable water type

The Logic Air cylinder is manufactured from duplex stainless steel using processes which make sure that the original corrosion protection qualities of the stainless steel are maintained. The grade of stainless steel selected is suitable for UK mains potable water only. If connecting these cylinders to other types of water supply please review the conditions of sale and guarantee terms at the rear of this manual. These products are not supplied with a protective anode.

CAUTION 6 - Installation in tall buildings

If the Logic air cylinder is to be installed in a location where it is above most of the outlets, for example in lofts or at the top of high buildings. We advise the installer to fit an anti vacuum valve. This is a precaution measure that will protect the cylinder from unforeseen circumstances and is good plumbing practice.

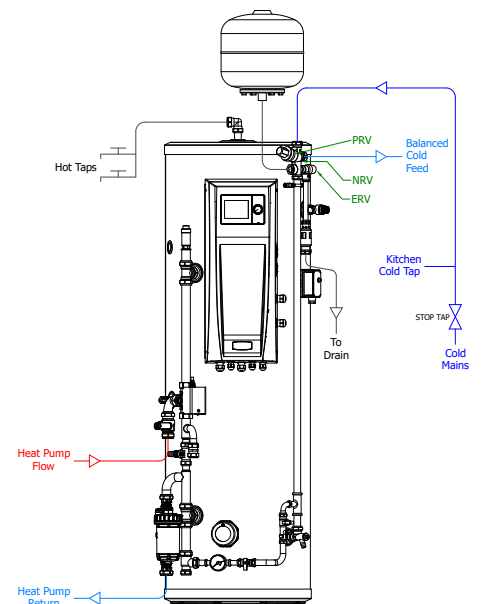

IDEPLUHP150PPSZSL

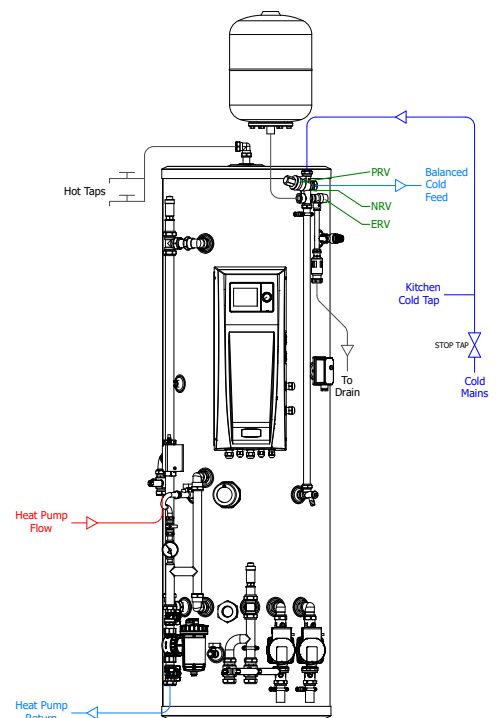

IDEPLUHP180DUOPPSZDZ

INSTALLATION

Make sure your selected product will fit in your selected location

Examine the product dimensions “Maximum width, depth and height” shown in tables 1, 2, 3, and 4 for your selected product.

Think through the clearances needed to move the product through the property to its final location and those needed in its final location. For example 100 mm either side of these dimensions may be required for maneuvering the product but less may be required in its final location.

Selection of product location considerations

Examine the product “Weight Full” shown in tables 1, 2, 3, and 4 for your selected product. Make sure that the floor of the chosen location can support at least more than this weight.

Make sure that the Mains water supply is Sufficient. Please review the guidance below and do a check on the water pressure and dynamic flow rate.

Guidance: Existing properties with a 15 mm supply will be satisfactory provided the local mains pressure is good, but should be confined to single bathroom properties. For new properties where simultaneous demand is required to more than one bathroom or a bathroom and one or more en-suites, the communication and service pipe into the dwelling should be a minimum of 22 mm (usually in the form of a 25 mm MDPE supply). The optimum performance is achieved if the inlet pressure is 3 bar dynamic. However, the Logic Air will function with lower inlet pressures, but this will reduce the performance. There should be a flow of at least 30 litres per minute or above available into the property. Normally the Logic air cylinder provides well in excess of 40 litres/min in most conditions. Flow rates for ALL mains pressure systems are subject to district pressures and system dynamic loss. Particularly on larger properties with more than one bathroom, the pipe sizes should be calculated in accordance with BS EN 806-3:2006 and BS 8558:2011.

Make sure that the selected location allows the following

1. The discharge pipework for the safety valves must have a minimum fall of 1 : 200 from the unit to a safe discharge point (Further details on the discharge requirements are provided in the next few pages).
2. All exposed pipework and fittings on the cylinder should be insulated, and the unit should NOT be fixed in a location where the contents could freeze. In new systems, pipes should be insulated to comply with building regs. The maximum permissible heat loss is indicated in the table below.
- i. Primary circulation pipes for domestic hot water circuits should be insulated through their length, subject only to practical constraints imposed by the need to penetrate joists and other structural elements.
- ii. All pipes connected to hot water storage vessels, including the vent pipe, should be insulated for at least 1 metre from their points of connection to the cylinder (or they should be insulated up to the point where they become concealed).
- iii. In replacement systems, whenever a boiler or hot water storage vessel is replaced in an existing system, any pipes that are exposed as part of the work or are otherwise accessible should be insulated as recommended for new systems, or to some lesser standard where practical constraints dictate.

Insulation of pipework	
Pipe outside diameter	Maximum heat loss
15 mm	7.89 W/m
22 mm	9.12 W/m
28 mm	10.07 W/m
35 mm	11.08 W/m

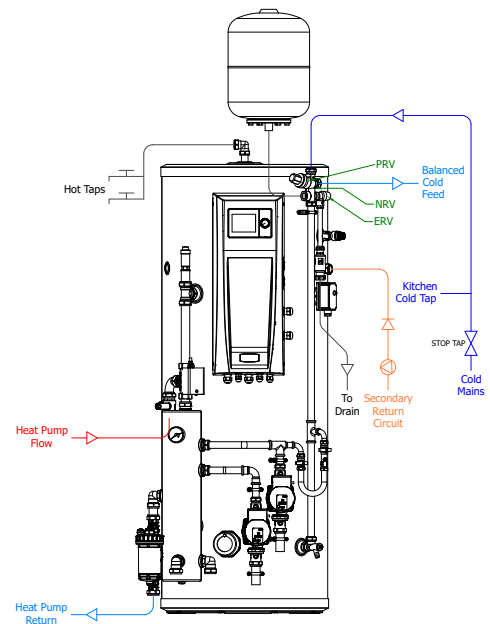

IDEPLUHP210PPDZ

Note 1. Further guidance on converting heat loss limits to insulation thickness for specific thermal conductivities is available in TIMSA “HVAC guidance for achieving compliance with Part L of the Building Regulations”.

Note 2. Our product have been designed with 28 mm pipework in mind. This is based upon the expectation that higher flow rates are required on heat pump systems.

Performance recommendations

The highest hot or cold water draw off point should not exceed 10 metres above the Pressure Reducing Valve.

In larger properties with a number of bathrooms/en-suites and long pipe runs we would recommend that the balance cold supply is provided with its own pressure reducing valve and is not taken from the balanced cold connection on the combination valve. In this case it will also be necessary to fit a small expansion vessel on the balanced cold water system to accommodate the pressure rise caused by the increase in temperature of the balanced cold water.

Check the performance requirements of the terminal fittings with regard to flow/pressure are suitable. Aerated taps are recommended to prevent splashing.

Shower Fitting Guidance

Any type of shower mixing valve can be used as long as both the hot and cold supplies are mains fed. However, all mains pressure systems are subject to dynamic changes particularly when other hot and cold taps/showers are opened and closed, which will cause changes in the water temperature at mixed water outlets such as showers. For this reason and because these are now no more expensive than a manual shower we strongly recommend the use of thermostatic showers with this appliance. These must be used in 3 storey properties where the impact on pressure/temperature of opening another tap in the system is greater than normal. The shower head provided must also be suitable for mains pressure supplies.

Pipe Layout

In all mains pressure installations it is important to remember that the incoming cold supply must be shared between all terminal fittings. It is important that a 22mm supply is brought to the appliance and a 22mm take-off is continued at least to the bath. If there are two baths, 28mm pipework should be considered. One metre of smaller diameter pipework, or flow restrictors, should be provided on the final connection to all outlets so as to balance the water available. In any event the distribution pipework should generally be in accordance with BS EN 806-1 to 5.

Plastic Pipework

This appliance is suitable for use with plastic pipework as long as the material is recommended for the purpose by the manufacturer and is installed fully in accordance with their recommendations.

Secondary Hot Water Circulation

All models 210 and above are fitted with a secondary return tapping as standard (see table 1 for details). If fitted, an extra expansion vessel may be necessary. A non-return valve MUST be FITTED near the return connection. No valve or terminal fitting should be installed between the non return valve and the cylinder. (See schematic arrangement on page 16.) All pipes kept hot by the secondary circulation should be insulated.

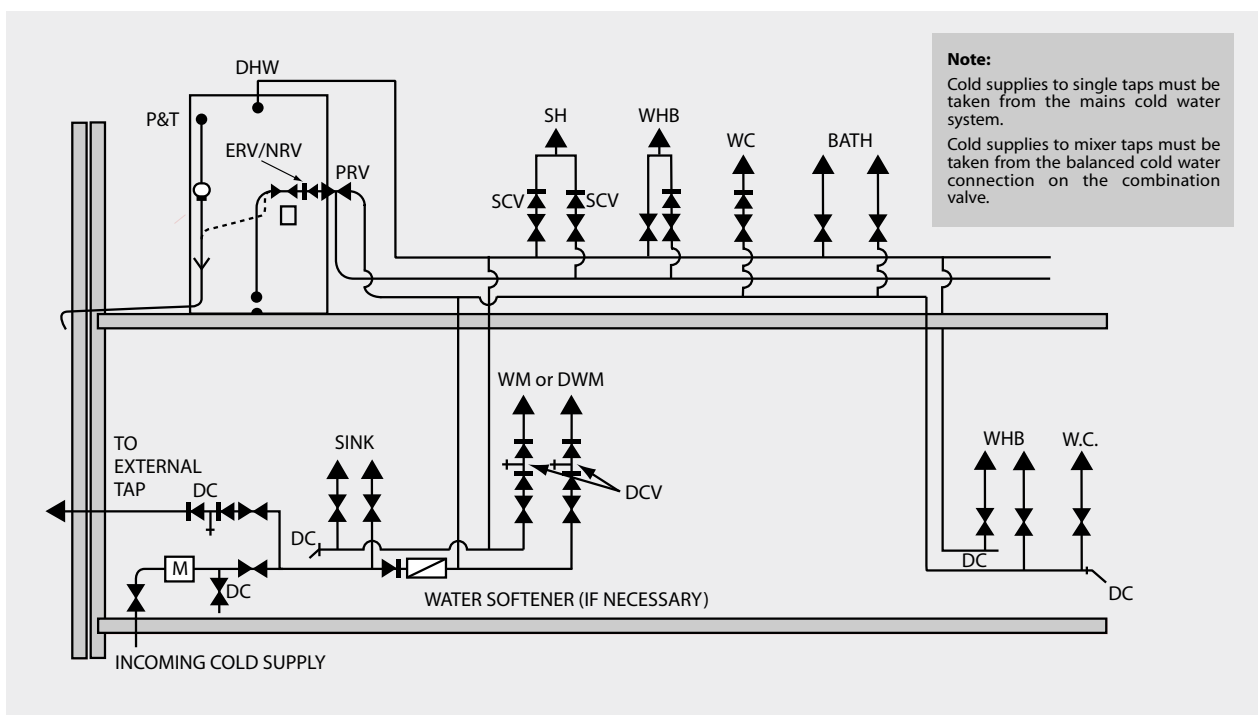

INSTALLATION

Typical Discharge Pipe Arrangement

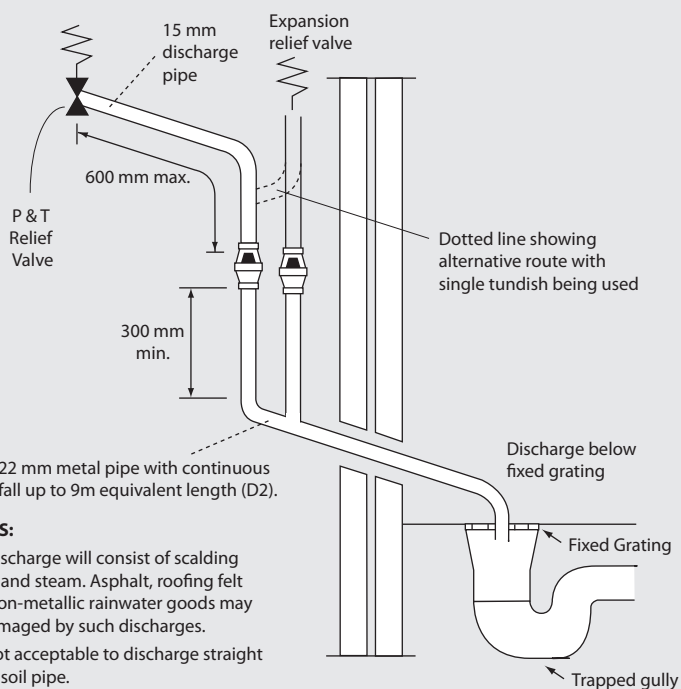

Pressure & Temperature/expansion Relief Valve Pipework

The relief valve should be installed to discharge in accordance with G3 of the Approved Document of the Building Regulations and should be piped to where it is visible, but will not cause danger to persons or damage to materials.

The following information is taken from Approved Document G3 of the Building Regulations and is provided to assist with the design and installation of the discharge pipework. However, the information is not exhaustive and reference should always be made to Approved Document G3 of the Building Regulations. The final decision regarding any arrangements rests with Building Control and it is recommended that their advice is sought if you have any concerns regarding this aspect of the installation.

The two safety valves will only discharge water under fault conditions. When operating normally water will not be discharged.

The tundish should be vertical, located in the same space as the unvented hot water storage system and be fitted as close as possible and within 600mm of the safety device e.g. the temperature relief valve.

The discharge pipe (D2) from the tundish should terminate in a safe place where there is no risk to persons in the vicinity of the discharge, or other material that has been demonstrated to be capable of safely withstanding temperatures of the water discharged and is clearly and permanently marked to identify the product and performance standard and:

- a) Be at least one pipe size larger than the nominal outlet size of the safety device unless its total equivalent hydraulic resistance exceeds that of a straight pipe 9m long i.e. discharge pipes between 9m and 18m equivalent resistance length should be at least two sizes larger than the nominal outlet size of the safety device, between 18 and 27m at least 3 sizes larger, and so on. Bends must be taken into account in calculating the flow resistance. Refer to the table and the worked example.

An alternative approach for sizing discharge pipes would be to follow BS EN 806-2:2005 Specification for design installation, testing and maintenance of services supplying water for domestic use within buildings and their curtilages.

Worked Example

The example below is for G1/2 temperature relief valve with a discharge pipe (D2) having 4 elbows and length of 7m from the tundish to the point of discharge.

From Table 1:

Maximum resistance allowed for a straight length of 22mm copper discharge pipe (D2) from a G1/2 temperature relief valve is: 9m subtract the resistance for 4 x 22mm elbows at 0.8m each = 3.2m.

Therefore the maximum permitted length equates to: 5.8m.

5.8m is less than the actual length of 7m therefore calculate the next largest size.

Maximum resistance allowed for a straight length of 28mm pipe (D2) from a G1/2 temperature relief valve equates to: 14m.

As the actual length is 7m, a 28mm (D2) copper pipe will be satisfactory.

Table 1: Sizing of copper discharge pipe 'D2' for a temperature relief valve with a G1/2 outlet size (as supplied)

Size of discharge pipework	Maximum length of straight pipe (no bends or elbows)	Deduct the figure below from the maximum length for each bend or elbow in the discharge pipe
22mm	Up to 9m	0.8m
28mm	Up to 18m	1m
35mm	Up to 27m	1.4m

- b) Have a vertical section of pipe at least 300mm long, below the tundish before any elbows or bends in the pipe work.
- c) Be installed with a continuous fall.
- d) It is preferable for the discharge to be visible at both the tundish and the final point of discharge but where this is not possible or practically difficult there should be clear visibility at one or other of these locations. Examples of acceptable discharge arrangements are:
 1. Ideally below the fixed grating and above the water seal in a trapped gully.
 2. Downward discharges at a low level; i.e. up to 100 mm above external surfaces such as car parks, hard standings, grassed areas etc are acceptable providing that where children play or otherwise come into contact with discharges, a wire cage or similar guard is positioned to prevent contact whilst maintaining visibility.
 3. Discharges at a high level; e.g. into metal hopper and metal down pipe with the end of the discharge pipe clearly visible (tundish visible or not) or onto a roof capable of withstanding high temperature discharges of water and 3 m from any plastic guttering systems that would collect such discharges.
 4. Where a single common discharge pipe serves more than one system, it should be at least one pipe size larger than the largest individual discharge pipe (D2) to be connected.
 5. If unvented hot water storage systems are installed where discharges form safety devices may not be apparent i.e. in dwellings occupied by blind, infirm or disabled people, consideration should be given to the installation of an electronically operated device to warn when discharge takes place.

Safety

The safety devices supplied or fitted on an StainlessLite Plus are selected for their suitability for the temperatures and pressures involved. They must not be changed, removed or by-passed and it is essential that only genuine replacement parts supplied or approved by Ideal heating Ltd are used. All parts are available to approved installers from Ideal heating spares department (Telephone 01482 498663).



Combination Inlet Group

Combines elements 1, 2 and 3 below.

1. *Pressure Reducing Valve* - The cold water supply to any mixer taps/showers must be taken from the cold water tapping of this valve to ensure balanced hot and cold pressures. This valve is factory set to ensure the correct operating pressure for the StainlessLite Plus.
2. *Non Return Valve* - This is integral with the pressure reducing valve to prevent backflow of hot water towards cold water draw off points.
3. *Cold Water Expansion Relief Valve* - This safety device is preset at the factory and will relieve excess cold water pressure resulting from a fault condition.

Line Strainer

This is integral within the combination inlet group to reduce the likelihood of contaminants fouling the valve seat. Following installation; Isolate the cold supply to the cylinder. Remove the inlet control group valve. Inspect the gauze filter on the inlet side of the valve and remove the debris.

Tundish

This is to allow the discharge from any Relief Valve to be seen. It must be fitted away from any electrical devices. See page 13 for discharge pipework details.

Expansion Vessels Installation

To prevent water stagnation and particulate accumulation affecting water quality, it is recommended that the expansion vessel be installed in the vertical orientation so that the fitting accommodating thermal expansion or a pressure surge is:-

1. bottom fed and upright; and
2. that the connecting pipework to the fitting:-
 - rises continuously; and
 - is kept to a minimum;

2 expansion vessels on 400 litre Models

All 400 litre models are supplied with two 24 litre expansion vessels. These can be coupled together and fitted to the expansion cylinder tapping on the combination inlet valve, or by some other means on the cold/hot water inlet pipework. There must be no valve on the pipe work between the expansion vessels and the unvented cylinder which could prevent the expansion of the water contained in the unvented cylinder reaching the expansion vessels.

Temperature/Pressure Relief Valve

This safety device is also pre-set at the factory and relieves before the temperature reaches 100°C. It is also a Pressure Relief Valve, and is pre-set to 6 bar.

INSTALLATION

WARNING: Danger of electrocution: before making any adjustments to the thermostat isolate the immersion heater from the mains electricity supply at the fuse spur unit.

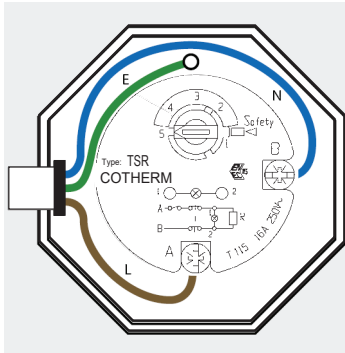

Immersion Heater Wiring

The immersion heater supplied with Heat pump products is set to position 5; so will operate in the range $68^{\circ}\text{C} \pm 3^{\circ}\text{C}$.

If the immersion heater thermostat is set too low then this may operate before the heat pump thermistor registers the temperature set by the user.

Check this manual's spares list for the correct immersion heater spares item. And check the thermostat setting is in position 5.

Immersion Heater

The immersion heaters fitted to our units are 3kW 240V ~AC. Check that the mains supply conforms to this, and all external wiring conforms to the most recent revision of the IEE wiring regulations. An Incoloy element is used on this product for standard domestic use and water conditions, use our Titanium elements in all other circumstances, part number SH002, (Check the thermostat is set to position 5).

The immersion heater is fitted into the hot water cylinder using an O-ring. After the unit is filled with water check for leaks to determine if the O-ring has sealed and tighten carefully using the appropriate tool. To prevent damage to the O-ring do not use excessive force to tighten the immersion heater.

The immersion heater is supplied with a thermostat which has been tested for operation in the cylinder and complies with the European directives for Electromagnetic compatibility and radio interference. It is Rated at 16 Amp 250V ~AC. The immersion thermostat has two terminals A and B. The Live (brown) wire should be connected to terminal A and the Neutral (blue) wire should be connected to terminal B. It has been our experience that Crimp terminals make better connections. The immersion heater must be fully earthed (earth post) and connected via a double pole isolator switch having a contact separation at least 3mm, see diagram above.

The immersion heater thermostats incorporate a manual reset safety/overheat cut out thermostat. Should this operate, investigate the cause for the operation cut out before pressing the red reset button labelled safety. If there is no apparent fault adjust the control setting down slightly to prevent nuisance tripping.

If another heat source is used to heat the cylinder and this is allowed to raise the water temperature excessively then the overheat thermostat will trip. This is likely on solar thermal products when the solar thermostats are set at high temperatures.

All Duo cylinders are fitted with a 3 kW immersion heater so that the store temperature can be raised above that which the heat pump provides, to boost the hot water performance if necessary and to protect against legionella eg. following the time parameters set on the Heat Pump remote control.

Control/Overheat Dual Thermostats

Care must be taken to ensure that the probes are fully inserted into the pockets provided.

Safety

StainlessLite Plus HP is fitted with a combined temperature and pressure relief valve to cope with any increase in temperature and pressure in the cylinder above the design limits, when used with heat sources up to 45kW total output. This is the maximum heat input to the cylinder allowed by section G3 of the 'Approved Document G' of the Building Regulations.

The heat supply to the cylinder is controlled from the control box supplied fitted to the unit.

The key control effectors in the heating process are

- the heat pump's DHW control thermistor
- the 3 port full divert valve,
- the manual reset thermostat
- immersion heater overheat thermostat
- Temperature and pressure relief valve.

Based upon the Control system parameters setup and DHW heating schedule the water will be heated when the control thermistor is measuring a temperature below the set point. The three port valve will open allowing heat energy to be supplied to the DHW cylinder's internal coil. When the temperature setting is exceeded the 3 port valve's power supply will be cut and its spring will divert the heat energy away from the coil.

The immersion heater may be called to support the heat pump in this process. It is controlled by the heat pump's DHW control thermistor.

The Logic Air Pre-plumbed cylinders are supplied with a cable clamp which screws into the thermostat pocket. This will hold the DHW thermistor, used by the heat pump control system, firmly in place.

The cylinder is protected by 2 manual reset over heat thermostats. One on the cylinder and the other in the immersion heater. If the cylinder mounted product operates power to the three port valve is cut, and power to the immersion it cut by it own.

The final level of safety is the Temperature and pressure relief valve. Which open between 90 and 95°C .

Heating And Primary Systems

Although the heat pump and the primary heating system should be sized and installed in accordance with BS EN 12828:2003, BS EN 12831:2003 & BS EN 14336:2004 the following should also be taken into account during the design and installation phase.

The heat pumps normally operate at lower flow temperatures; typically 45 – 55°C compared with 75 – 80°C for the boilers. Therefore if traditional radiators are used then, these should be oversized in accordance with the heat pump manufacturers recommendations.

For optimum efficiency (i.e. COP of a heat pump), low temperature under floor heating system should be considered.

The heat pumps normally operate at lower temperature difference between flow and return compared with the traditional boilers and therefore when sizing the pipework heat pump manufacturers recommendations should be taken into account.

INSTALLATION

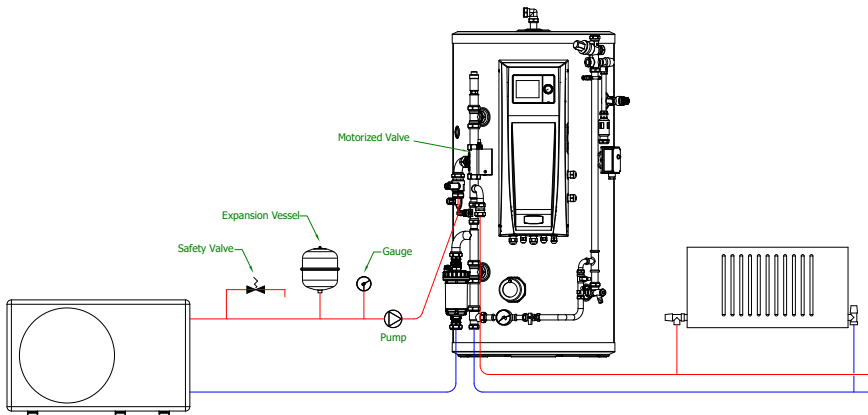

IDEPLUHP150PPSZ
Sealed Primary System

The Logic air pre-plumbed cylinders are supplied pre wired.

- **Sealed heating system**

The heat pump selected must be suitable for use in a sealed heating system which may have working pressure of up to 3.0bar and it must be fitted with an overheat temperature cut-out device.

- **Circulation pumps**

The pre-plumbed single zone cylinders do not have a CH pump fitted to them. The circulation pump in the heat pump unit is expected to be able to provide enough flow for the central heating circuit.

The Duo single zone, Duo twin zone and Standard twin zone products have circulation pumps for the central heating zones.

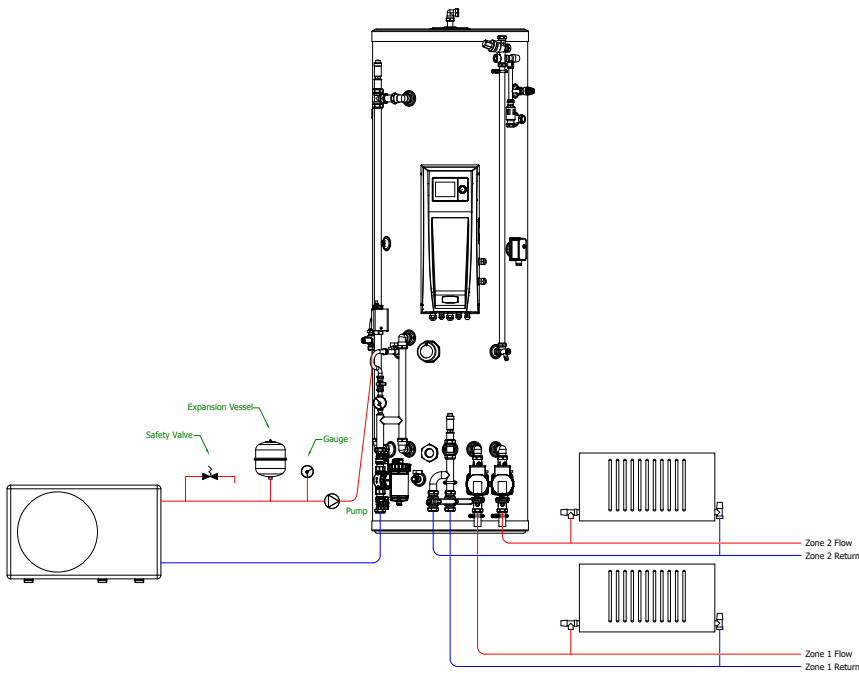

IDEPLUHP300DUOPDZ
Sealed Primary System

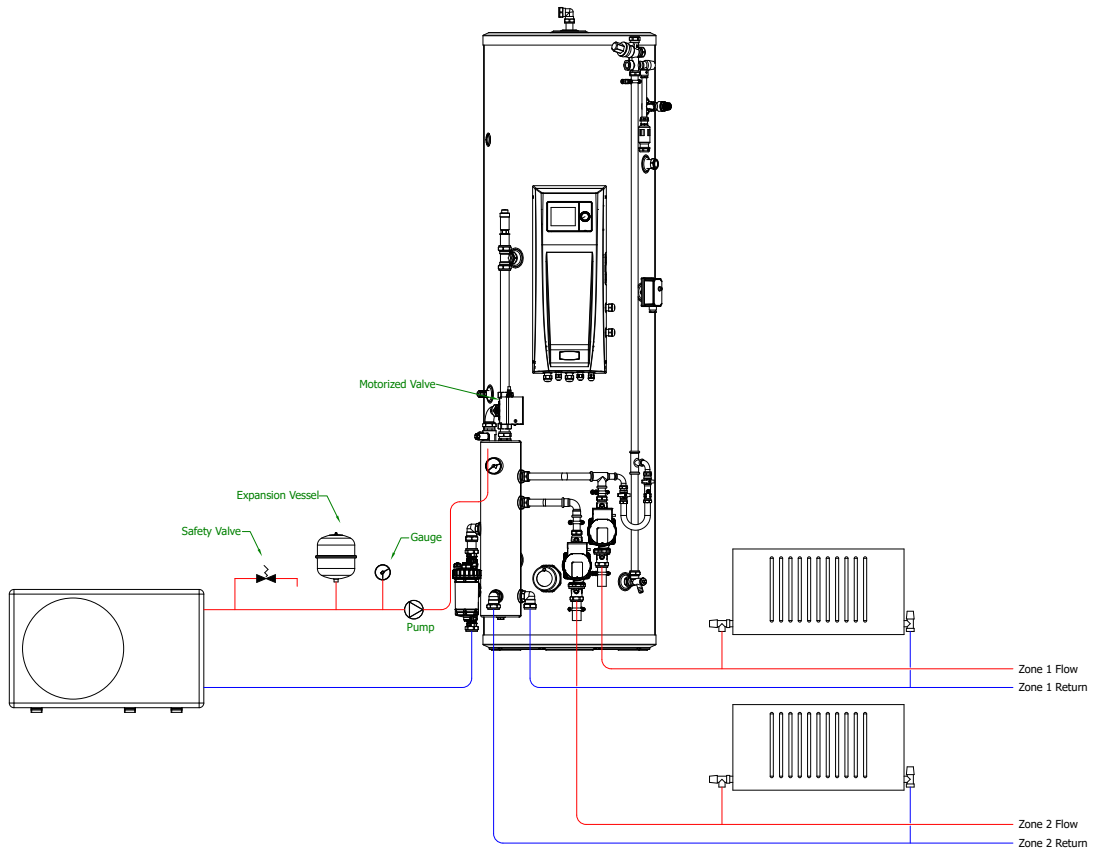

IDEPLUHP300PPDZ
Sealed Primary System

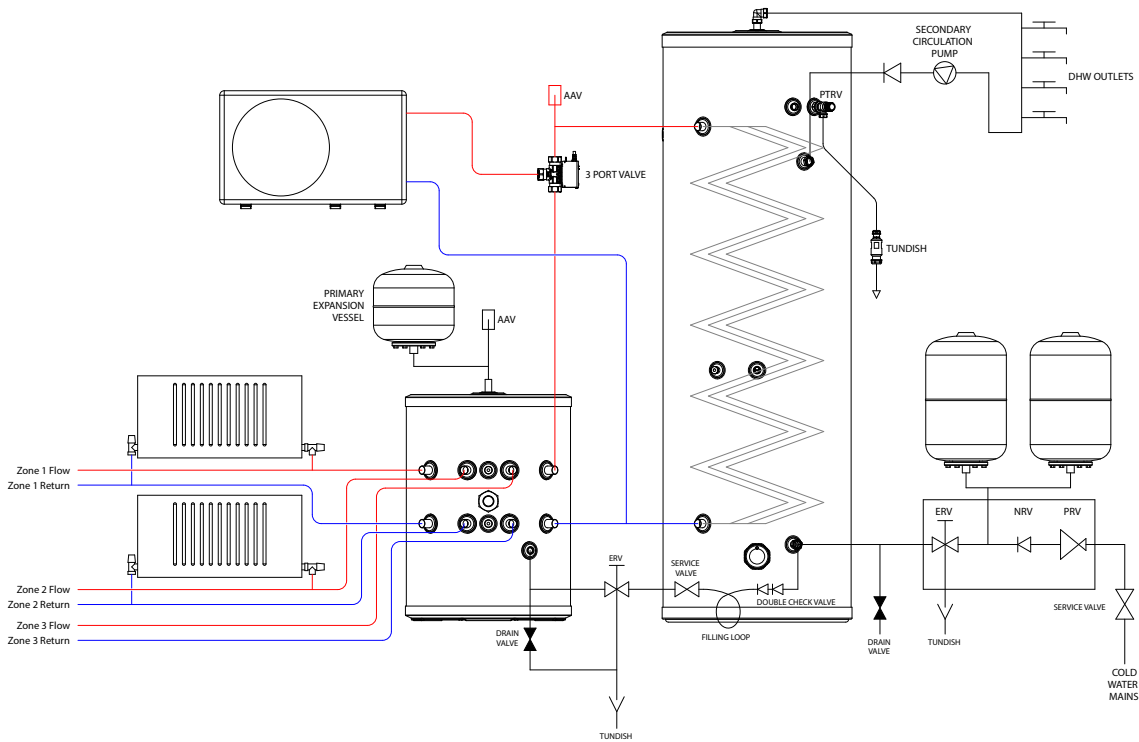

IDEPLUHP400 + IDEPLU090MB
Sealed Primary System

INSTALLATION

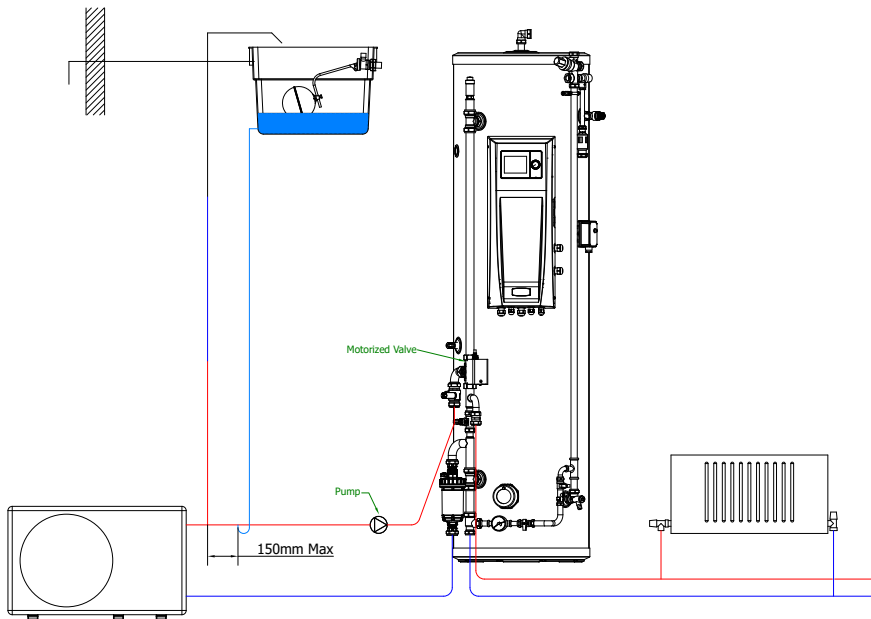

IDEPLUHP180PPSZL
Open Vented System

- **Open vented heating system**

It is essential that the primary circuit between the boiler and the StainlessLite Plus is pumped and that the cold feed and open vent connections are positioned to prevent pump over into the feed and expansion cistern and to ensure that the open vent is correctly sized. Typical arrangements of the open vented system are shown in the diagrams on these 2 pages.

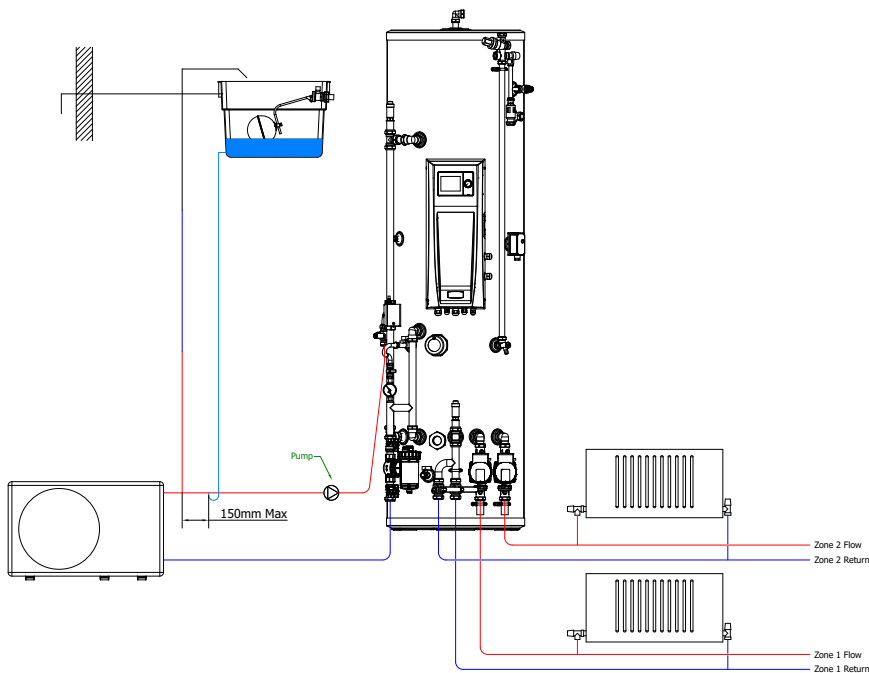

IDEPLUHP210DUOPDZ
Open Vented System

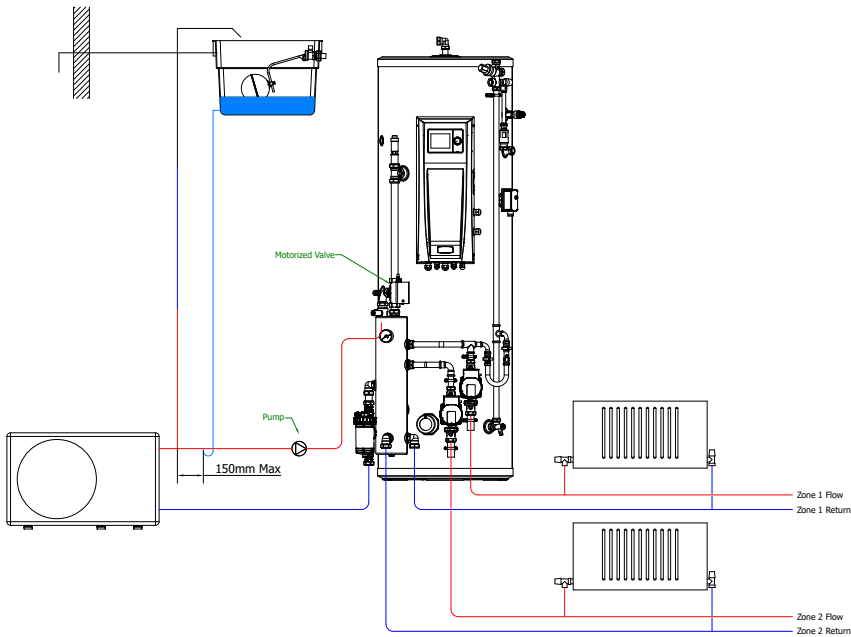

**IDEPLUHP250PPDZ
Open Vented System**

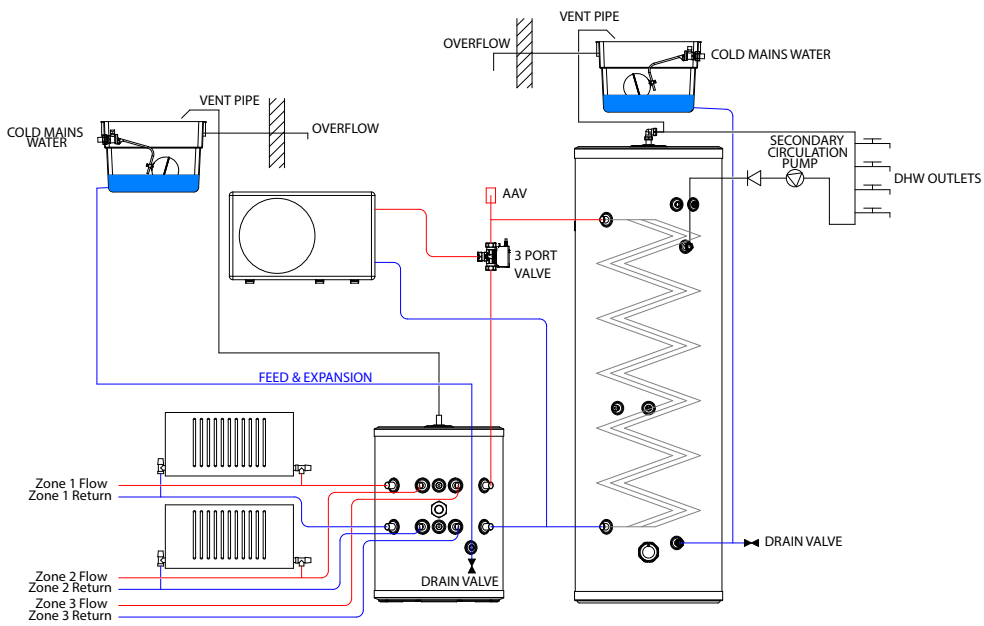

**Open Vented 400 + Buffer
Schematic Assembly**

INSTALLATION

CAUTION

Connections can come loose in transit, and all should be checked before installation.

Make sure that the immersion heater achieves a temperature of at least 60°C in the store and that the wiring is in accordance with the diagram.

Do a check of the pressure on the air side of the expansion vessel = 3 bar. This must be done when the water in the cylinder is free to expand in atmospheric pressure (disconnected from the system) or the cylinder and relevant pipe work is empty.

Make sure that the drain cock is closed, and open all the cold and hot water taps and other terminal fittings. Allow the system to fill with water, and to run until there is no air left in the system. Close the taps and inspect the system closely for leaks.

Manually open the Relief Valves one by one and make sure that water is discharged and run freely through the tundish and out at the discharge point. The pipework should accept full bore discharge without overflowing at the tundish, and the valve should seat satisfactorily.

In line with good plumbing practice, use with excessive flux should be avoided. When soldering above the cylinder, ensure flux/solder does not contaminate the cylinder below, since this can cause corrosion, Flushing should be done performed as per BS EN 806:4 2010 section 6.2

Allow the cylinder to heat to normal working temperature, then thoroughly flush the domestic hot and cold water pipework through each tap.

NOTE: If this appliance is to be installed in other than a single domestic dwelling ie. in an apartment block or student flats etc., the hot and cold water system will need to be disinfected in accordance with BS EN 806:4 2010 section 6.3 and the Water Regulations.

Because the Logic air cylinder are made from stainless steel, the use of chlorine as the disinfection agent can cause damage unless the appliance is adequately flushed and refilled with the mains water immediately on completion of the disinfection procedure. Damage caused through a failure to do this adequately will not be covered by the warranty.

For the above reasons we recommend the use of a non chlorine dosed disinfectant such as Fernox LP Sterox as manufactured by Cookson Electronics when carrying out disinfection of systems incorporating these appliances.

Allow the cylinder to heat to normal working temperature with whatever heat source is to be used, and check again for leaks. The Pressure Relief Valve should not operate during the heating cycle. If the P&T valve operates before the pressure relief valve due to high pressure, check that the inlet control group is fitted correctly, and no valve is between the inlet control group and the cylinder.

The heat pump/heating systems should be filled and commissioned in accordance with good practice following the guidance in BS 7593:2006/the heat pump manufacturers instructions. This includes adequately flushing the system to remove any debris that may have been introduced during installation/maintenance.

The combination inlet control group service is as follows; Isolate the cold supply to the cylinder. Remove the inlet control group valve. Inspect the guaze filter on the inlet side of the valve and remove the debris.

NOTE

At the time of commissioning, complete all relevant sections of the Benchmark Checklist located on the inside back pages of this document.

This must be completed during commissioning and left with the product to meet the Warranty conditions offered by Ideal Heating.

IMPORTANT - DRAIN DOWN PROCEDURE

- 1 Switch off both the heat pump and the immersion heater
- 2 Open the nearest hot tap and run all hot water until cold
- 3 Close the incoming cold main at the stop tap
- 4 **Hold open the pressure and temperature relief valve until water stops discharging into the tundish**
- 5 Open all the taps in the property
- 6 Open the drain cock and immediately hold open the pressure and temperature relief valve again until the cylinder is empty

USER INSTRUCTIONS

Your Logic Air HP or Duo unvented cylinder is automatic in normal use, but requires routine maintenance which is normally carried out at least annually along with the heat pump service. The maintenance must be carried out by a suitably competent tradesperson who is qualified to work on unvented cylinders. The checks/work needed are listed in the maintenance part of these Instructions.

The heat pump control thermostat should switch to the hot water zone valve before the heat pump starts to cycle on its internal thermostats. For example if the maximum primary flow temperature available from the heat pump is 55°C, then the control thermostat should be set to 48°C. (This setting should not be changed by the occupant.)

When initially opening the taps, a small surge in flow may be experienced, which disappears as the pressure in the system stabilises. This is quite normal with these types of systems and does not indicate a fault.

In some areas the water will initially appear cloudy, but will quickly clear when left to stand. This is nothing to be concerned about and is due to aeration of the water.

WARNING - If water is seen flowing through the tundish, this indicates a fault condition which needs action.

If the discharge is hot and continuous, turn the Heat Pump and/or the immersion heaters off, but do not turn off the cold water to the appliance until the discharge is cold.

Note: The discharge may stop by itself as the discharge cools.

If the discharge is cold and intermittent, no immediate action is needed but this indicates a problem with the expansion vessel.

However, in both cases you must call the registered installer / a suitably qualified, competent tradesperson, advise them that you have an unvented cylinder and request a maintenance visit.

DO NOT, at any time, tamper in any way with the safety valves or overheat thermostats/wiring.

SERVICING AND MAINTENANCE

The Registered Installer is responsible for the safe installation and operation of the system. The installer must also make his customer aware that periodic maintenance of the equipment is essential for safety.

Maintenance periods will vary for many reasons. Ideal Heating Ltd recommend a maximum of 12 months to coincide with heat pump maintenance. Experience of local water conditions may indicate that more frequent maintenance is desirable, eg, when water is particularly hard, scale-forming or where the water supply contains a high proportion of solids, eg, sand. Maintenance must include the following:

1. Isolate the cold supply to the cylinder. Remove the inlet control group valve. Inspect the gauze filter on the inlet side of the valve and remove the debris.
2. Manually check the operation of the temperature relief valve.
3. Manually check the operation of the expansion relief valve.
4. Check discharge pipes from temperature and expansion relief valves are free from obstruction and blockage and are not passing any water.
5. Check the condition and if necessary descale the heat exchangers in hard water areas.
6. Check that water pressure downstream of pressure reducing valve is within the manufacturers limits.
7. Check operation of motorised valve.
8. Check the pressure on the air side of the expansion vessel. This must be done with the pressure on the water side at zero (gauge pressure).
9. Check and advise the householder not to place any clothing or other combustible materials against or on top of this appliance.
10. On completion of the work, fill in the Benchmark Service Record at towards the back of this manual.

IMPORTANT NOTE

When draining down the appliance for any reason, the instructions provided in the Commissioning Section MUST be followed to prevent potential damage to the cylinder.

After servicing, complete the relevant Service Interval Record section of the Benchmark Checklist located on the inside back pages of this document.

Scale

In hard water areas it is recommended that an in-line scale inhibitor is fitted. Reducing the temperature of the stored water will reduce the rate at which scale forms. If the recovery rate is badly affected, this is an indication that scaling may have occurred. In this event, follow the procedures as recommended by a reputable Water Treatment Company.

General

No water at the tap. Check that the mains water supply is turned ON. Check the line strainer is not blocked. Check that the combination valve has been fitted so that water is flowing in the correct direction.

If the water at the tap is cold, ensure that the boiler has been switched ON and is working correctly. Check that there are no air locks in the primary system. ISOLATE THE UNIT AT THE MAINS ELECTRIC SUPPLY AND THEN CHECK THE FOLLOWING:

- i. The cylinder thermostat
- ii. The thermal cut-out, which can be re-set by pushing the red button
- iii. The motorised valve
- iv. The thermostat is correctly set
- v. The heat pump thermostat cut-out (if fitted)

ANY ENERGY CUT-OUT MUST NEVER BE BY-PASSED UNDER ANY CIRCUMSTANCES.

If the unit is not getting hot and the heat source is electrical, ensure that the immersion heaters are isolated from the mains before re-setting the energy cut-out. If the immersion heater(s) need replacing this should be done with the units supplied from Ideal heating Limited. Same day despatch to approved installers can be arranged by telephoning 01482 4986 

Discharge From Relief Valves

If cold water is discharging from the expansion relief valve into the tundish check the pressure on the expansion vessel when cold and recharge if necessary.

If the fault continues and the problem cannot be stopped by operating the easing control a few times then either the Pressure Reducing Valve or the Relief Valve may be at fault. If the cold water pressure is too high, this would suggest that the Pressure Reducing Valve is at fault and the Ideal approved replacement should be fitted. If the pressure is correct then the Relief Valve will require replacing with a Ideal approved component.

See Commissioning for drain down procedure.

If there is an overheat fault and very hot water is being discharged, turn off the heat source, **but not the water supply.**

When the supply is cool, check thermostats and energy cut-outs in the heat pump and immersion heaters and replace the faulty component with one supplied by Ideal Heating Limited and check that it works correctly before returning the system to full operation.

FAULT FINDING

FAULT - No Hot Water

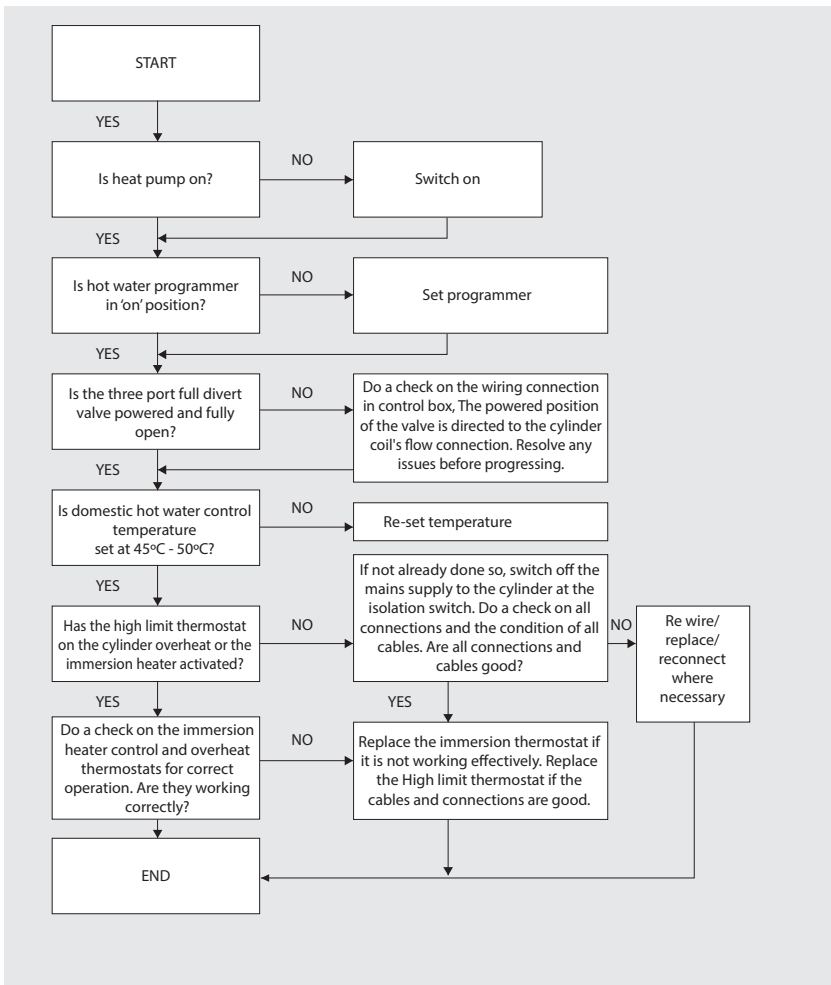

FAULT - Poor Water Flow at Hot Taps

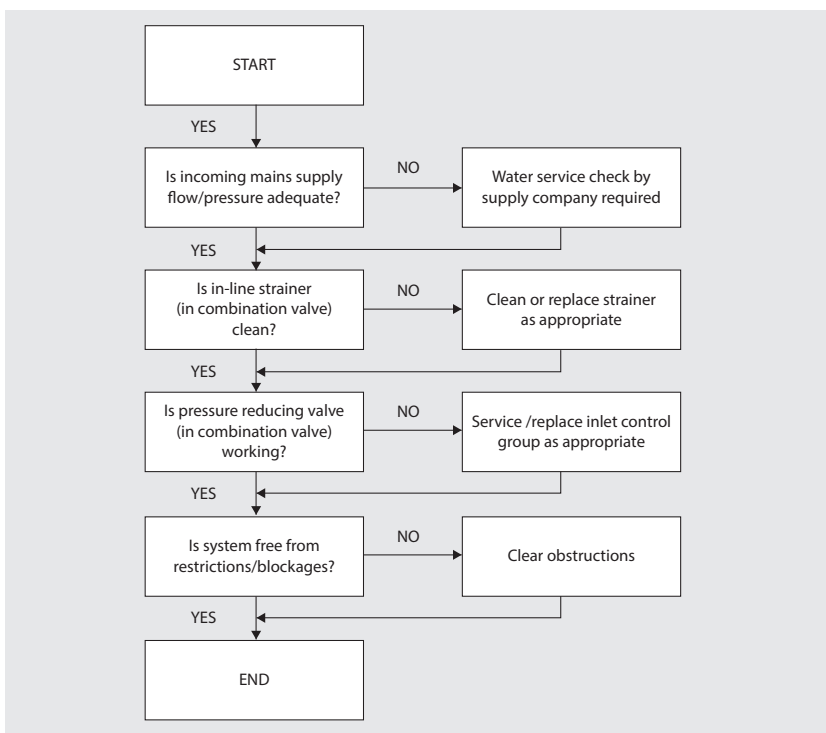

FAULT - Water Discharge Into Tundish

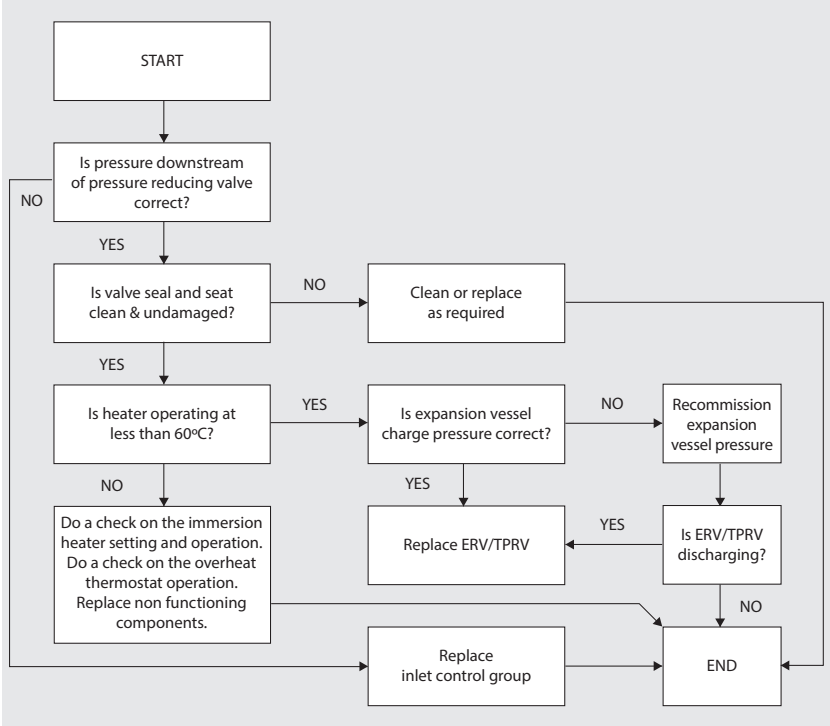

SPARE PARTS LIST					
	Description	Quantity	Stock Code No.	Std.	Duo
1	3 kW immersion element	1	SH018	✓	✓
2	22 mm 90° compression elbow	1	SF003	✓	✗
3	Pressure and temperature relief valve 6 bar 92-95° bar	1	SG019 (309463 GLD)	✓	✓
4	Inlet group set at 3 bar c/w expansion relief valve set at 4.5 bar	1	SG034	✓	✓
5	18 litre expansion vessel	1	XG225	✓	✓
6	24 litre expansion vessel	1	XG226	✓	✓
7	35 litre expansion vessel	1	XG227	✓	✓
8	15 mm x 22mm tundish	1	XG173	✓	✓
9	28 mm 3 port valve with 1" MBSP threaded connections	1	CP019	✗	✓
10	½" automatic air vent	1	GT015	✗	✓
11	1¾" immersion blank	1	FT467	✗	✓
12	50 mm diameter pressure gauge	1	XG120	✗	✓
13	Differential pressure relief valve	1	XG156	✗	✓
14	Double check valve (Filling loop)	1	XG004	✗	✓
15	Double check valve (Filling loop)	1	XG005	✗	✓
16	Double check valve (Filling loop)	1	XG006	✗	✓

APPENDIX

Water Savings

Water Related Costs Can Be Reduced By Good Plumbing Practice

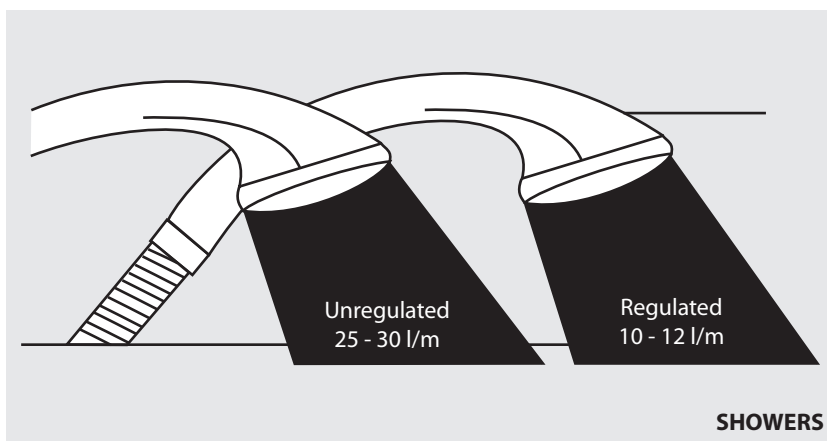
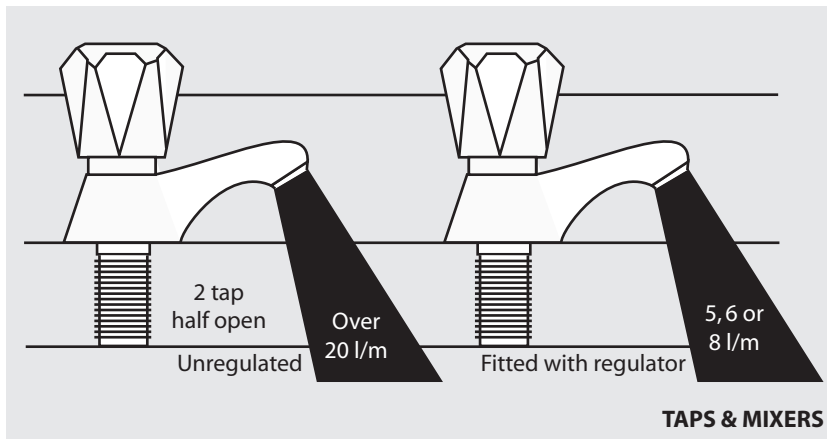

Vast quantities of water are needlessly run off to waste due to Taps, Mixers and Showers discharging flow rates far in excess of the rates required for them to perform their duties.

The contrasting flow rates shown on this leaflet clearly illustrate the savings that can be made whilst still providing a good performance.

British made Aquaflow Regulators provide constant flow rates by automatically compensating for supply pressure changes between 1 bar & 10 bars.

To facilitate installation into the wide range of plumbing equipment which is encountered in the U.K, Four Fixing Options are available:-

Options For Showers

1. MXF "DW" Range - For fitting behind Fixed Shower Heads or onto Flexible Hoses for Handshowers (preferably onto the inlet end when lightweight hoses are used).
2. Compression Fitting Range. "In Line" regulators as in Option 4 for Taps & Mixers.

Information by courtesy of

AQUAFLOW REGULATORS LTD

Haywood House, 40 New Road, Stourbridge, West Midlands DY8 1PA
TELEPHONE (01384) 442611 FAX: (01384) 442612

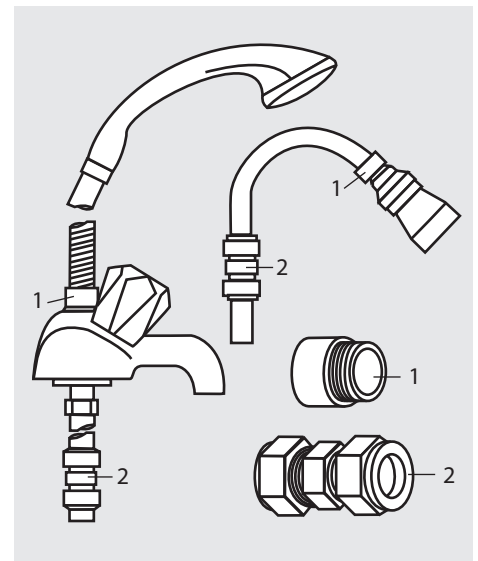

4 Fixing Options For Taps & Mixers

1. MK Range - Combined Regulators & Aerator for screwing onto Taps & Mixers with internal or external threads on their noses. Anti Vandal models also available.
2. MR05-T Range - Internal Regulators. Push-fit into Tap or Mixer seats. Produced in three sizes - 12.5mm (BS1010), 12mm & 10mm, Flangeless models also available for Taps with Low Lift washers.
3. MXF Standard Range - Screw on tail models for Taps & Mixers. Fix onto the tails before fitting the tap connectors. Available in 3/8", 1/2", 3/4" and 1" BSP.
4. Compression Fitting Range - "In Line" regulators housed in 15mm & 22mm CXC Couplers & Isolating Valves. "UKWFBS" listed by the Water Research Centre. Isolation valves available for slotted screwdriver operation or with coloured plastic handles. Now available also in plastic bodied push-fit couplers & valves.

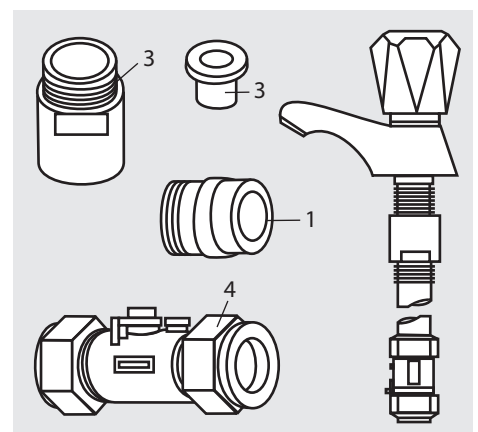

APPENDIX

MANUAL HANDLING OF APPLIANCE PRODUCTS

Description

Manual handling means any transporting or supporting of a load (including lifting, putting down, pushing, pulling, carrying or moving) by hand or bodily force.

Scope

This assessment will cover the largest unit within each product range.

For specific weights and dimensions please refer to technical data section.

Main Hazards

Vision may not be clear due to the size of the products.
Adopting an incorrect method of lifting may cause injury, attempting to lift these products will require help from others. (Team lifts)

Control Measures

Manual lifting procedure

The lift, key factors in safe lifting are:

- a. **Balance**
 - b. **Position of back**
 - c. **Positioning of the arms and body**
 - d. **The hold**
 - e. **Taking the lead for team lifts**
-
- a. **Balance** - Since balance depends essentially upon the position of the feet, they should be apart about hip breadth with one foot advanced giving full balance sideways and forward without tension. In taking up this position, lifting is done by bending at the knees instead of the hips and the muscles that are brought into use are those of the thigh and not the back.
 - b. **Position of back** - Straight - not necessary vertical. The spine must be kept rigid, this coupled with a bent knee position, allows the centre line of gravity of the body to be over the weight so reducing strain.
 - c. **Positioning of arms and body** - The further arms are away from the side, the greater the strain on the shoulders, chest and back. Keep elbows close to the body arms should be straight.
 - d. **The hold** - Before lifting ensure you have a good hold.

- e. **Taking the lead for team lifts**- As more than one person is required for these products ensure that one person is taking the lead. **This may be you** so ensure that each person that is helping is made aware of the weight and of the items listed within this assessment. Make sure you and any others helping know the route you intend to take that it is clear of any obstructions. Never jerk the load as this will add a little extra force and can cause severe strain to the arms, back and shoulders. If there are steps involved decide on where you will stop and take a rest period. Move smoothly and in unison taking care to look and listen to others helping with the lift. Where possible use a sack truck to move the product over long flat distances, only lift the products when necessary. If in doubt stop and get more help.

Individual capability

Individual capability plays an important part in handling these products. Persons above average build and strength will find it easier and should be in good health. Persons below average build and strength may require more rest periods during the handling process.

Pregnant women should not carry out this operation.

Persons who are not in good health should seek medical advice prior to commencing any lifting or manual handling operation.

Residual risk

Following the guidelines given above will reduce any risk to injury.

All persons carrying out this operation must be fully trained and copies of the specific risk assessment made available for inspection and use in their training process.

Further guidance on Manual Handling can be obtained from the Health and Safety Executive. Manual Handling Operations Regulations 1992 (amended by Health and Safety (Miscellaneous Amendments) Regulations 2002.

TERMS AND CONDITIONS

Ideal Unvented Cylinder Warranty Terms and Conditions

Ideal Boilers Limited provides a 2 year parts and labour warranty on the cylinder solution provided, the inner cylinder skin is further covered for on a replacement basis beyond this period to 25 years from the date of purchase, subject to adherence with the following terms and conditions of warranty

1. The unit has been installed and commissioned in accordance with our installation and service instructions and all relevant codes of practice and regulations in force at the time of installation.
2. All necessary inlet controls and safety valves have been fitted correctly.
3. The unit has only been used for the storage of potable water supplied from the public mains. The water quality shall be in accordance with
4. European Council Directive 98/83 EC, or revised version at the date of installation, and is not fed with water from a private supply. Particular:
Chloride content: Max. 200 mg/l
Sulphate content: Max. 200 mg/l
Combination chloride/sulphate: Max. 300 mg/l (in total)
5. If the newly fitted water heater is not in regular use then it must be flushed through with fresh water for at least 15 minutes. Open at least one hot water tap once per week, during a period of at least 4 weeks.
6. The Cylinder is registered within 30 days of installation, this can be done by calling Ideal Boilers on **01482 498660**
7. The unit has been regularly maintained as detailed in the installation and service instructions
8. If the Cylinder suffers a mechanical breakdown, calls must be raised with Ideal Boilers Customer Services on **01482 498660**
Our normal working times, excluding Bank Holidays are:
8am – 6pm Monday to Friday, 8am – 4pm Saturday,
8.00am – 12 noon Sunday
9. The guarantee for the stainless steel vessel is for twenty five years against material defect or manufacturing faults if the original unit is returned to us AND PROVIDED THAT:
 - (i) It has not been modified, other than by Ideal.
 - (ii) It has not been subjected to wrong or improper use or left uncared for.
 - (iii) It has only been used for the storage of potable water supplied from the public mains, max 200mg/litre chloride.
 - (iv) It has not been subjected to frost damage.
 - (v) The benchmark service record is completed after each annual service.
 - (vi) The unit has been serviced annually
10. If the stainless steel vessel proves to be defective either in materials or workmanship we reserve the right to either repair or supply replacements or the closest possible substitute in the case of any obsolete product and will collect and deliver to any address in England, Scotland and Wales (excluding all islands):
Our normal working times, excluding Bank Holidays are:
8am – 6pm Monday to Friday, 8am – 4pm Saturday,
8.00am – 12 noon Sunday
Please note:
 - a. Engineers will only attend to Ideal products where it is considered by the engineer that the installation does not pose a risk to health and safety.
 - b. A permanently fixed access ladder must service installations in lofts or attics. Adequate lighting and permanently fixed flooring must also be available.
 - c. Compartment installations must provide minimum working clearances as detailed in the installation instructions. Ideal will not accept responsibility for the removal of fixtures or fittings in order to gain access for repairs.
11. The guarantee does not apply:
 - a. If the Cylinder is removed from its place of installation without our prior consent.
 - b. To any defect, damage or breakdown caused by inadequate servicing of the cylinder or by deliberate action, accident, misuse or third party interference including modification or an attempted repair which does not fully comply with industry standards.
 - c. To any defect, damage or breakdown caused by the design, installation and maintenance of the central heating system.
 - d. To de-scaling or other work required as a result of hard water scale deposits or from damage caused by aggressive water or sludge resulting from corrosion.
 - e. If the claim/contact procedure set out in section 12 is not adhered to
 - f. To any other costs or expenses caused by or arising as a result of the breakdown of an Ideal Cylinder.
 - g. To any defect resulting from the incorrect installation of the cylinder.
 - h. To any costs incurred during delays in fixing reported faults.
12. We reserve the right to charge a call-out fee where:
 - a. A fault cannot be found.
 - b. The breakdown or fault has been caused by an event, which is excluded from the guarantee – refer to section 11
 - c. Failure to cancel an agreed appointment prior to our engineers visit
 - d. The Cylinder is outside the period of guarantee or the conditions of the guarantee have not been met.
13. If we fit replacement parts or replace a cylinder it will not extend the period of the warranty. All replaced parts or cylinders will become the property of Ideal Boilers Ltd.
14. The warranty applies only where an Ideal cylinder has been installed in a domestic dwelling in mainland United Kingdom, Northern Ireland and I.O.W. to provide hot water.

Our Ideal Warranty is offered in addition to the rights provided to a consumer by law. Details of these rights can be obtained from a Trading Standards Authority or a Citizen Advice Bureau. Guarantor – Ideal Boilers Ltd, P.O. Box 103, National Avenue, Hull, HU5 4JN.

MAINS PRESSURE HOT WATER STORAGE SYSTEM COMMISSIONING CHECKLIST

This Commissioning Checklist is to be completed in full by the competent person who commissioned the storage system as a means of demonstrating compliance with the appropriate Building Regulations and then handed to the customer to keep for future reference.

Failure to install and commission this equipment to the manufacturer's instructions may invalidate the warranty but does not affect statutory rights.

Customer name:										Telephone number:														
Address:																								
Cylinder Make and Model																								
Cylinder Serial Number																								
Commissioned by (PRINT NAME):										Registered Operative ID Number														
Company name:										Telephone number:														
Company address:																								
										Commissioning date:														
To be completed by the customer on receipt of a Building Regulations Compliance Certificate*:																								
Building Regulations Notification Number (if applicable)																								
ALL SYSTEMS PRIMARY SETTINGS (indirect heating only)																								
Is the primary circuit a sealed or open vented system?										Sealed					Open									
What is the maximum primary flow temperature?															°C									
ALL SYSTEMS																								
What is the incoming static cold water pressure at the inlet to the system?															bar									
Has a strainer been cleaned of installation debris (if fitted)?										Yes					No									
Is the installation in a hard water area (above 200ppm)?										Yes					No									
If yes, has a water scale reducer been fitted?										Yes					No									
What type of scale reducer has been fitted?																								
What is the hot water thermostat set temperature?															°C									
What is the maximum hot water flow rate at set thermostat temperature (measured at high flow outlet)?															l/min									
Time and temperature controls have been fitted in compliance with Part L of the Building Regulations?										Yes														
Type of control system (if applicable)										Y Plan					S Plan					Other				
Is the cylinder solar (or other renewable) compatible?										Yes					No									
What is the hot water temperature at the nearest outlet?															°C									
All appropriate pipes have been insulated up to 1 metre or the point where they become concealed										Yes														
UNVENTED SYSTEMS ONLY																								
Where is the pressure reducing valve situated (if fitted)?																								
What is the pressure reducing valve setting?															bar									
Has a combined temperature and pressure relief valve and expansion valve been fitted and discharge tested?										Yes					No									
The tundish and discharge pipework have been connected and terminated to Part G of the Building Regulations										Yes														
Are all energy sources fitted with a cut out device?										Yes					No									
Has the expansion vessel or internal air space been checked?										Yes					No									
THERMAL STORES ONLY																								
What store temperature is achievable?															°C									
What is the maximum hot water temperature?															°C									
ALL INSTALLATIONS																								
The hot water system complies with the appropriate Building Regulations										Yes														
The system has been installed and commissioned in accordance with the manufacturer's instructions										Yes														
The system controls have been demonstrated to and understood by the customer										Yes														
The manufacturer's literature, including Benchmark Checklist and Service Record, has been explained and left with the customer										Yes														
Commissioning Engineer's Signature																								
Customer's Signature																								
(To confirm satisfactory demonstration and receipt of manufacturer's literature)																								

*All installations in England and Wales must be notified to Local Authority Building Control (LABC) either directly or through a Competent Persons Scheme. A Building Regulations Compliance Certificate will then be issued to the customer.



SERVICE RECORD

It is recommended that your hot water system is serviced regularly and that the appropriate Service Record is completed.

Service Provider

Before completing the appropriate Service Record below, please ensure you have carried out the service as described in the manufacturer's instructions.

SERVICE 01		Date:	SERVICE 02		Date:
Engineer name:		Engineer name:		Engineer name:	
Company name:		Company name:		Company name:	
Telephone No:		Telephone No:		Telephone No:	
Comments:		Comments:		Comments:	
.....		
.....		
.....		
Signature		Signature		Signature	
SERVICE 03		Date:	SERVICE 04		Date:
Engineer name:		Engineer name:		Engineer name:	
Company name:		Company name:		Company name:	
Telephone No:		Telephone No:		Telephone No:	
Comments:		Comments:		Comments:	
.....		
.....		
.....		
Signature		Signature		Signature	
SERVICE 05		Date:	SERVICE 06		Date:
Engineer name:		Engineer name:		Engineer name:	
Company name:		Company name:		Company name:	
Telephone No:		Telephone No:		Telephone No:	
Comments:		Comments:		Comments:	
.....		
.....		
.....		
Signature		Signature		Signature	
SERVICE 07		Date:	SERVICE 08		Date:
Engineer name:		Engineer name:		Engineer name:	
Company name:		Company name:		Company name:	
Telephone No:		Telephone No:		Telephone No:	
Comments:		Comments:		Comments:	
.....		
.....		
.....		
Signature		Signature		Signature	
SERVICE 09		Date:	SERVICE 10		Date:
Engineer name:		Engineer name:		Engineer name:	
Company name:		Company name:		Company name:	
Telephone No:		Telephone No:		Telephone No:	
Comments:		Comments:		Comments:	
.....		
.....		
.....		
Signature		Signature		Signature	



At Ideal Heating we take our environmental impact seriously, therefore when installing any Ideal Heating product, please make sure to dispose of any previous appliance in an environmentally conscious manner. Households can contact their local authority to find out how. See <https://www.gov.uk/managing-your-waste-an-overview> for guidance on how to efficiently recycle your business waste.

TECHNICAL TRAINING

Our Expert Academy offer a range of training options designed and delivered by our experts in heating. For details please contact: expert-academy.co.uk

Ideal Boilers Ltd., pursues a policy of continuing improvement in the design and performance of its products. The right is therefore reserved to vary specification without notice.

Ideal is a trademark of Ideal Boilers.

Registered Office

Ideal Boilers Ltd., National Avenue, Hull, East Yorkshire, HU5 4JB

Tel 01482 492251 Fax 01482 448858

Registration No. London 322 137

EU Authorised Representative:

Atlantic SFDT

44 Boulevard des Etats-Unis, 85 000 La Roche-Sur-Yon, France

+33 (0)2 51 44 34 34

Ideal Technical Helpline: 01482 498663

Ideal Consumer Helpline: 01482 498660

Ideal Parts: 01482 498665

 idealheating.com

ideal
HEATING