

---

# Time Delay Relay Replacement Kit for Hydronic Air Handler



**Kit Part Numbers: AHPARTS03**

## Parts List

1. Time Delay Relay

## Tools required:

- Screwdriver #3 Slotted
- Screwdriver #3 Phillips
- 5/16" Nut Driver
- Continuity checker
- Pliers



---

### WARNING

**Indicates a potentially hazardous situation which, if ignored, can result in serious injury or substantial property damage.**

### NOTICE

**Indicates special instructions on installation, operation or maintenance, which are important to equipment but not related to personal injury hazards.**

---

### WARNING

Failure to follow instructions below can result in severe personal injury or damage if ignored.

- Instructions are for a qualified installer/ service technician.
- Read all instructions before proceeding.
- Follow instructions in proper order.

### WARNING

**For your safety, turn off electrical power supply at service panel before proceeding to avoid possible electrical shock hazard. Failure to do so can cause severe personal injury or death.**

# Time Delay Relay Replacement Kit for Hydronic Air Handler

## Removal of TD Relay

1. Disconnect electrical power supply to the Hydronic Air Handler.
2. Remove eight 5/16" hex head screws and remove front panel.

### NOTICE

**Use care not to damage or scratch the front panel when removing from cabinet.**

3. Lay front panel away from unit and expose the TD-Relay and control wiring.
4. Mark the green wire from the Fan Relay to the TD Relay and Mark the red wire connected to the TD Relay for future reference.
5. Disengage the line and control wiring from the TD Relay. (see Fig. 1)
6. Use a 5/16" nut driver to remove the mounting screws on the existing TD Relay and remove the TD Relay from the control panel.

## Installation of TD Relay

1. Mount the new TD Relay onto the control panel using (2) existing 5/16" hex head screws.

### NOTICE

**When mounting the TD-Relay, ensure the mounting screws do not come in contact with and damage the hydronic coil located behind the electrical panel.**

2. Using a continuity checker to reference the coil contacts of the TD Relays. The coil contacts will show a close circuit.
3. Attached the marked green and red wires to the coil contacts
4. Attached the 24-volt low voltage wires to the TD Relay. See Fig.1.
4. Reattached the front panel and secure with existing eight 5/16" Hex Head screws.
5. Turn the power on the unit and return the Hydronic Air Handler to service.

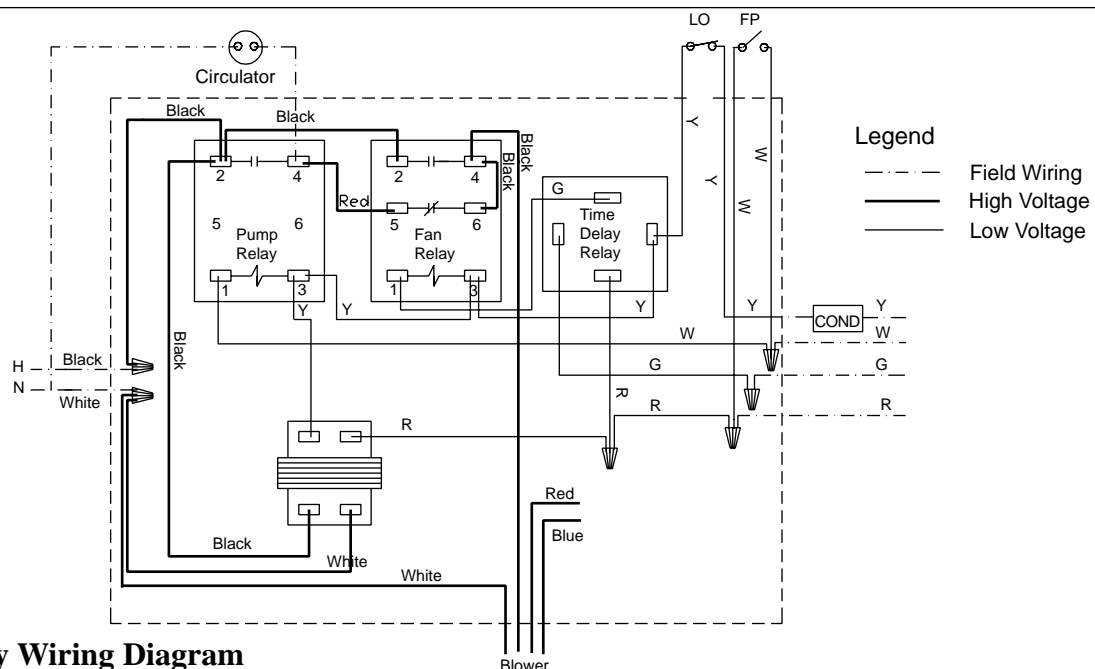

**Fig. 1: Factory Wiring Diagram**