

---

# PVC/CPVC Low Profile Sidewall Vent Termination Kit

---



**Kit Part Number:**

**PSVTERM03**

2 Inch PVC/CPVC Vent Sidewall Termination

**PSVTERM04**

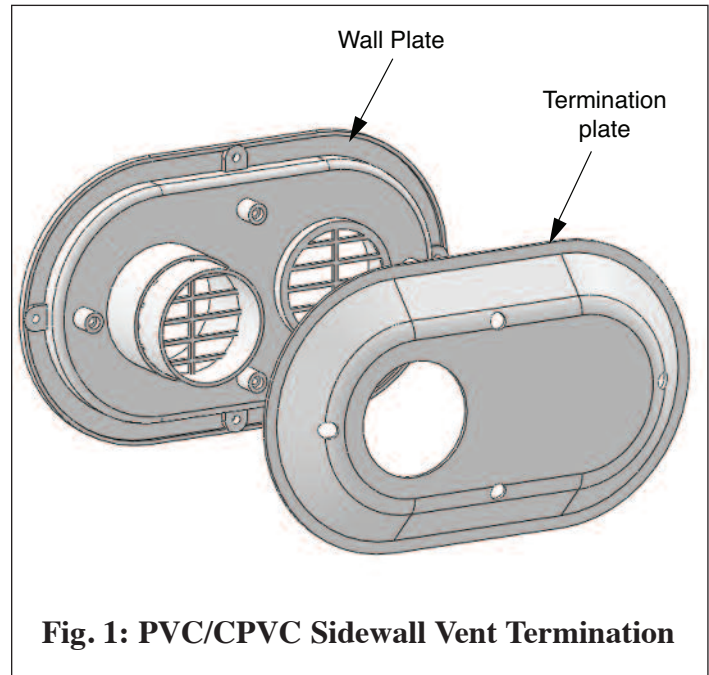
3 Inch PVC/CPVC Vent Sidewall Termination

**PSVTERM05**

4 Inch PVC/CPVC Vent Sidewall Termination

**Recommended tools:**

- Phillips Screwdriver
- Core Drill or Hole Saw



**⚠ WARNING**

Indicates a potentially hazardous situation which, if ignored, can result in serious injury or substantial property damage.

**NOTICE**

Indicates special instructions on installation, operation or maintenance, which are important to equipment but not related to personal injury hazards.

---

**⚠ WARNING**

Failure to follow instructions below can result in severe personal injury or damage if ignored.

- Instructions are for a qualified installer/service technician.
- Read all instructions before proceeding.
- Follow instructions in proper order.

**NOTICE**

The sidewall vent termination is certified to ULC S636 standard.

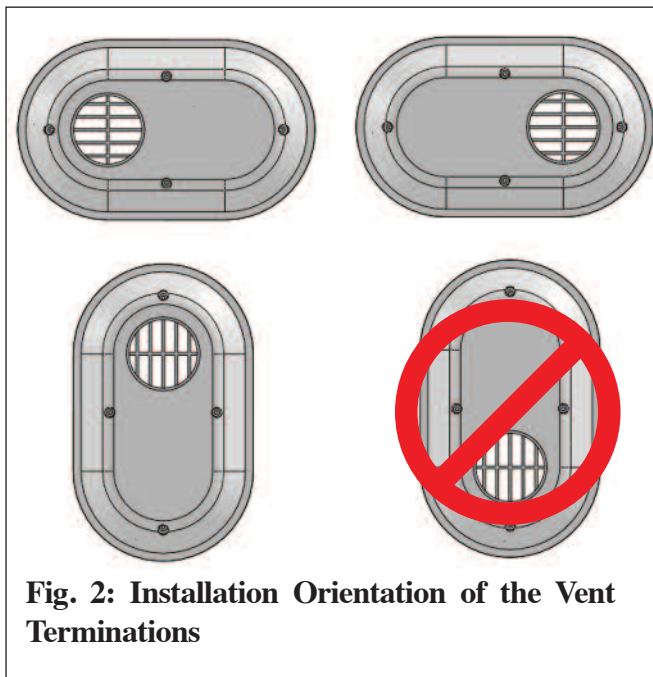
**NOTICE**

This vent termination must be installed in accordance with all applicable local, state, national and provincial codes, ordinances, regulations and laws.

# PVC/CPVC Low Profile Sidewall Vent Termination Kit

## Pre-Installation Guidelines

1. The vent termination location must maintain all termination clearances stated in Section II Direct Vent Installation of the Vent Supplement included with the boiler.
2. Ensure vent termination location does not exceed the maximum allowable vent length as listed in the boiler Vent Supplement.
3. The sidewall Vent Termination is suitable for PVC or CPVC vent systems and may be installed in a horizontal or vertical configuration as shown in Fig. 2.



### WARNING

When installing the vent termination in a vertical configuration, ensure the vent piping is located above the air inlet piping. This will avoid the risk of flue gas products recirculating into the air inlet and building.

### NOTICE

For installations in Canada, all piping, fittings and cement/primer material must comply with ULC S636 certification.

### NOTICE

Do not use cellular core piping for the venting system.

### WARNING

**DO NOT mix vent components from different vent systems. Use only PVC and/or CPVC pipe and fittings. Seal all pipe and fittings with appropriate primer and cement. Failure to comply with these requirements could cause venting system failure resulting in leakage of flue products into the living space.**

4. All vent piping and assembly / gluing of the vent piping should comply with the guidelines referenced in the boiler's Vent Supplement.
5. For multiple vent termination installation, reference Figure 5 for vertical orientations and Figure 6 for horizontal orientation.

## Installation of the Vent Termination

1. Use the wall plate as a template to locate the penetration holes through the outside wall. Reference Table 1 on page 3 for the proper hole diameter.
2. Use a core drill or hole saw to cut the penetration holes through the outside wall.

### WARNING

When locating the penetration of the vent and air pipes ensure the termination is properly oriented as shown in Fig. 2. For multiple vent terminations ensure the vent and air penetration are at the same height. Failure to do so can result in severe personal injury or substantial property damage.

---

## PVC/CPVC Low Profile Sidewall Vent Termination Kit

---

**Table 1**

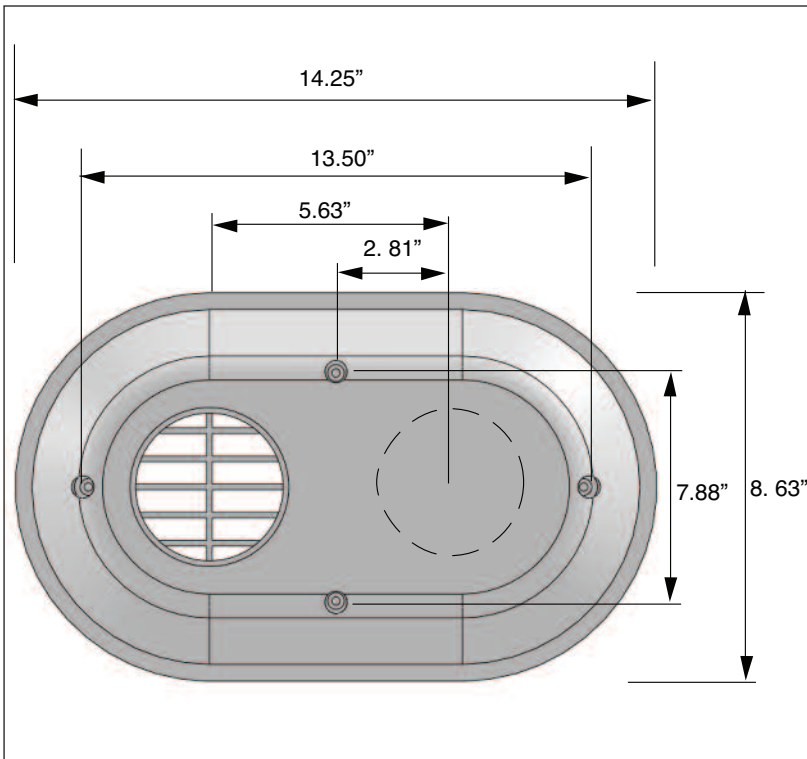
Pipe Size	Vent Pipe Hole Size	Air Pipe Hole Size
2" PVC/CPVC	4"	2 3/8"
3" PVC/CPVC	4"	3.5"
4" PVC/CPVC	5"	4.5"

3. Use the wall plate as template to locate the mounting holes on the outside wall.
  - For masonry type walls drill a 3/16" hole and insert the anchors supplied with the vent.
  - For wood type wall drill a 1/8" pilot hole at each location.
4. Install the air intake piping and the vent piping through the penetration holes. Ensure the air intake piping extends beyond the exterior face of the wall 1" and the vent piping extends 2 1/4" beyond the exterior face of the wall.
5. Prior to cementing the wall plate to the vent and air pipes. The installer should:
  - Deburr the inside and outside of the pipe ends.
  - Chamfer the outside of the pipe ends to allow even distribution of cement when joining.
  - Clean and dry the pipe ends and wall plate fittings.
6. When assembling the wall plate to the vent and air pipes the installer should:
  - a. Handle the wall plate and pipes carefully to prevent contamination of surfaces.
  - b. Apply a liberal amount of primer to the end of the pipes and the wall plate sockets.
  - c. Apply a light uniform coating of approved cement to both surfaces. The end of the pipes and the sockets of the wall plate, while the primer is still wet.
  - d. With the cement still wet, the wall plate should be mounted onto the pipe ends. Ensure the pipe end is inserted fully into the socket of the wall plate.
7. From the inside of the exterior wall apply a bead of high temp silicone (RTV) around the vent and air intake piping where it penetrates through the wall.
8. Secure the wall plate to the exterior wall using the mounting screws supplied with the vent.
9. Install the termination plate onto the wall plate as shown in Figure 1 using the screws supplied with the vent termination.

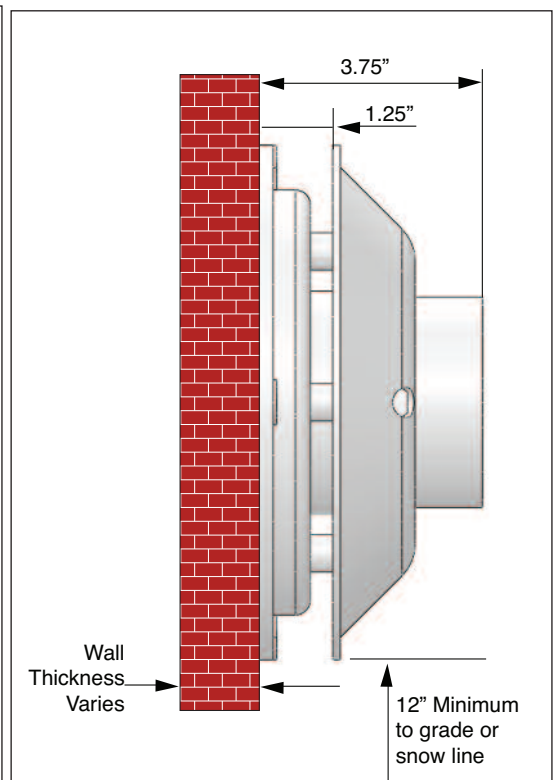
**NOTICE**

**Prior to assembly/gluing wall plate the vent and air piping, dry fit the wall plate to ensure it mounts flush against exterior wall.**

# PVC/CPVC Low Profile Sidewall Vent Termination Kit

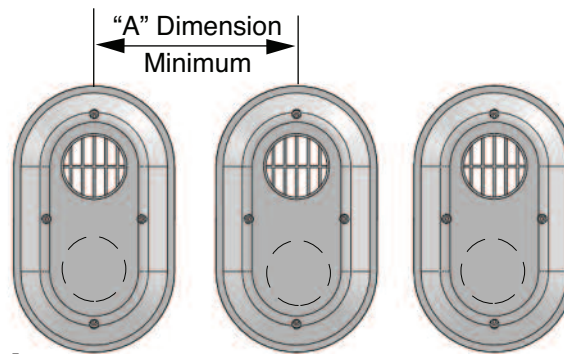


**Fig. 3: Vent Termination Dimensions**



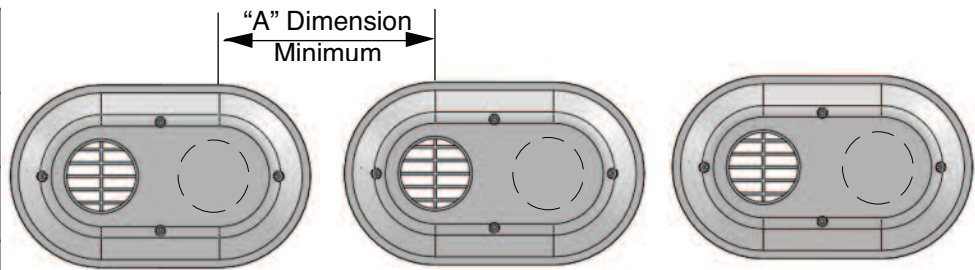
**Fig. 4: Vent Termination Dimensions**

Vent Size	“A” Dimension
2 Inch	14.50
3” Inch	15.50
4” Inch	16.50



**Fig. 5: Multiple Vent Termination - Vertical**

Vent Size	“A” Dimension
2 Inch	14.50
3” Inch	15.50
4” Inch	16.50



**Fig. 6: Multiple Vent Termination - Horizontal**