

Engineering Submittal Prestige Solo 155



ACVMax Control System

- Graphical display with 6 navigation buttons
- EZ Setup allows quick and easy boiler settings adjustment
- Presets allow quick configuration of 4 circulator outputs
- Each circulator output is fully configurable for custom applications
- Outdoor temperature reset to maximize efficiency
- Accepts two space heating call inputs with independent outdoor reset curves
- Simultaneously heat dual temperature heating systems with built-in mixing valve control
- Domestic hot water priority with optional time-out
- Integrated cascade control for up to 6 Prestige boilers
- 0-10 VDC Modulation input
- Modbus building management system (BMS) interface, LonWorks® and BACnet® interface optional
- Adjustable warm weather shutdown
- Adjustable boiler freeze protection
- Logging function records sensor readings for system optimization and troubleshooting
- Describes lockouts in plain english and suggests solutions while storing last 8 errors

Prestige Solo Features

- Light weight construction for wall mounting
- Approved for zero clearance to combustibles
- 3" PVC, CPVC, PP, or AL29-4C venting up to 100 equivalent feet
- Limited 5 year warranty on parts, except igniter
- Limited 10 year warranty on heat exchanger

Approvals

- 95% AFUE Efficiency
- ENERGY STAR Qualified
- ANSI Z21.13 and CSA 4.9 Boiler Standards Compliance
- ASME Boiler Certification – ASME "H" Stamp
- Low NOx operation exceeding SCAQMD 2012 regulations

Stainless Steel Fire Tube Heat Exchanger

- 439 Stainless Steel heat exchanger construction for corrosion resistance
- Low pressure drop minimizes circulator size
- High water content provides stable temperature control
- Self cleaning flue ways reduce maintenance
- Suitable for use with propylene glycol up to 50% concentration

Standard Equipment

- Stainless steel premix burner
- Direct spark ignition with variable speed blower
- Full modulation with turndown ratio of 5.5:1
- Automatic air vent
- ASME 30 PSI pressure relief valve
- Integrated pressure and temperature gauge
- Outdoor temperature sensor
- Automatic low water cutoff feature with early warning
- High temperature manual reset limit safety control
- Terminal block for circulator output
- Low voltage terminal strip with removable jumpers for manual or automatic reset limits
- Swing out control for easy access and servicing
- Alarm and flame status contacts
- Polypropylene condensate pan and internal flue pipe
- Polypropylene vent/air connections with test ports

Project / Location: _____	Date: _____
Consulting Engineer / Architect: _____	
Mechanical Contractor: _____	

Boiler Dimensions

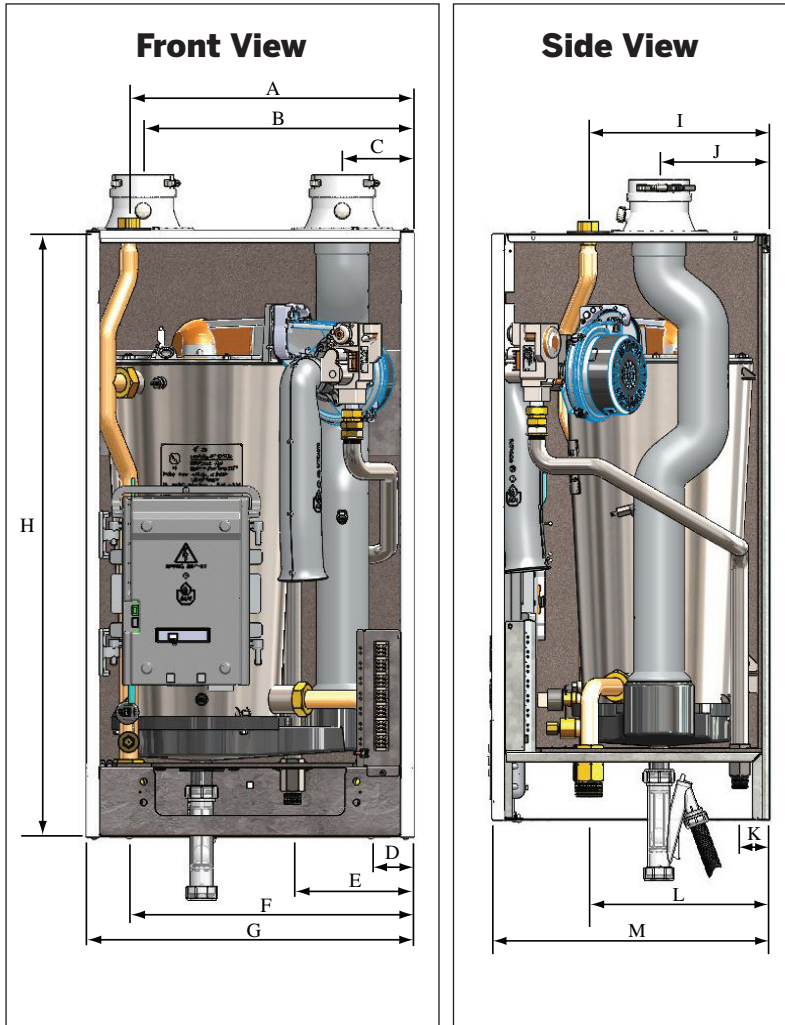

Letter	Connection	Dimension in [mm]
A	3/4" NPSC Pressure Relief Valve	17" [432]
B	3" Combustion Air Inlet	16-5/16" [415]
C	3" Vent Outlet	4-5/16 [110]
D	1-1/4" NPT Boiler Return	2-9/16" [65]
E	3/4" NPT Gas Connection	7-5/16" [186]
F	1-1/4" NPT Boiler Supply	17" [432]
G	Boiler Width	19-3/4" [502]
H	Boiler Height	36-9/16" [928]
I	3/4" NPSC Pressure Relief Valve	11-5/16" [288]
J	3" Combustion Air Inlet & 3" Vent Outlet	6-15/16" [175]
K	3/4" NPT Gas Connection	1-7/8" [48]
L	1-1/4" NPT Boiler Return & Supply	11-5/16 [288]
M	Boiler Depth	17-5/16" [440]

Boiler Specifications

Model	Fuel	Input Modulation (MBH)	AFUE	DOE Heating Capacity (MBH)	Net AHRI (MBH)	Boiler Water Volume (gal)	Power	Shipping Weight Lbs
Solo 155	Natural Propane	27.8 - 153	95%	142	123	4	120/1/60 FLA: 10A	118

Pressure Drop Curve vs Grundfos Circulators

