



# VENT SUPPLEMENT

Gallant 250-299-399

## **WARNING**

If the information in this manual is not followed exactly, a fire or explosion may result causing substantial property damage, serious injury, or death.

### **FOR YOUR SAFETY**

- Do not store or use gasoline or other flammable vapors and liquids in the vicinity of this or any other appliance.

### **• WHAT TO DO IF YOU SMELL GAS**

- Do not try to light any appliance
- Do not touch any electrical switch; do not use any phone in your building.
- Immediately call your gas supplier from a neighbor's phone. Follow the gas supplier's instructions.
- If you cannot reach your gas supplier, call the fire department.

**Installation and service must be performed by a qualified installer, service agency or the gas supplier.**

## **NOTICE**

- Customer must register unit within thirty (30) days of installation in order to gain warranty coverage. See Warranty Card for details.
- To maintain the safety & longevity of your appliance, read and follow the maintenance schedule information throughout this manual.
- Leave all documentation received with appliance with the owner for future reference.



## TABLE OF CONTENTS

---

<b>PRODUCT AND SAFETY INFORMATION.....</b>	<b>V</b>
<b>CHAPTER 1 - PRE-INSTALLATION REQUIREMENTS .....</b>	<b>VI</b>
1.1. Removal of an Existing Boiler from a Common Vent System .....	vi
1.2. Vent/Combustion Air Piping and Materials.....	vi
1.2.1 PVC and CPVC Vent and Combustion Air Piping and Fittings.....	1
1.2.2 PVC and CPVC Pipe Cement and Primer .....	1
1.2.3 AL29-4C® Stainless Steel Vent Piping and Fittings .....	1
1.2.4 Polypropylene (PP) Vent Piping and Fittings .....	1
1.3. Vent/Combustion Air Equivalent Lengths .....	2
1.4. Vent Restrictions .....	2
1.4.1 3 Inch [80 mm] Vent System Restrictions .....	2
1.4.2 Rigid Polypropylene Vent System Restrictions .....	2
1.4.3 Flex Polypropylene Vent System Restrictions .....	3
1.5. Combustion Air Contamination .....	8
2.1. Direct Vent - Vertical - Through the Roof or Unused Chimney .....	9
2.1.1 Determine Termination Location .....	9
<b>CHAPTER 2 - DIRECT VENT INSTALLATION OF VENT/AIR PIPING .....</b>	<b>9</b>
2.1.2 Direct Vent - Vent Installation - Through the Roof.....	10
2.1.3 Termination Fittings - Through the Roof .....	10
2.1.4 Direct Vent - Multiple Boiler Installation - Through the Roof.....	10
2.2. Direct Vent - Horizontal - Sidewall .....	11
2.2.1 Determine Termination Location .....	11
2.2.2 Direct Vent - Vent Installation - Sidewall .....	13
2.2.3 Termination Fittings - Sidewall.....	13
2.2.4 Direct Vent - Multiple Boiler Installation - Sidewall.....	15
2.3. Direct Vent - Vertical Vent and Sidewall Combustion Air.....	15
2.3.1 Determine Termination Location .....	16
2.3.2 Direct Vent - Vent Installation - Through the Roof.....	18
2.3.3 Direct Vent - Combustion Air Installation - Sidewall .....	18
2.3.4 Termination Fittings - Vertical & Sidewall .....	20
2.3.5 Direct Vent - Multiple Boiler Installation - Vertical Vent and Sidewall Combustion Air	20
<b>CHAPTER 3 - CATEGORY IV (INDOOR AIR) INSTALLATION OF VENT/AIR PIPING ....</b>	<b>21</b>
3.1. Category IV - Vertical - Through the Roof or Unused Chimney .....	21
3.1.1 Determine Termination Location .....	21
3.1.2 Category IV - Vent Installation - Through the Roof.....	22
3.1.3 Termination Fittings - Through the Roof .....	22
3.1.4 Category IV - Multiple Boiler Installation - Through the Roof.....	23

## TABLE OF CONTENTS

---

3.2. Category IV - Horizontal - Sidewall .....	23
3.2.1 Determine Termination Location .....	23
3.2.2 Category IV - Vent Installation - Sidewall .....	25
3.2.3 Termination Fittings - Sidewall .....	25
3.2.4 Category IV - Multiple Boiler Installation - Sidewall.....	25
<b>CHAPTER 4 - INSTALLATION REQUIREMENTS .....</b>	<b>26</b>
4.1. Vent/Combustion Air Transitions .....	26
4.1.1 3 in. [80 mm] to 4 in. [100 mm] Transitions.....	26
4.2. Connect Piping to GALLANT .....	26
4.3. Vent and Combustion Air Piping Installation.....	27
4.3.1 PVC/CPVC Vent System.....	27
4.3.2 Polypropylene or Stainless Steel Vent Systems .....	28
4.4. Carbon Monoxide Detector Installation .....	28
<b>CHAPTER 5 - MANIFOLD COMBUSTION AIR .....</b>	<b>29</b>
5.1. Manifold Combustion Air Option for Multiple GALLANT Boilers.....	29
5.2. Combustion Air Manifold Equivalent Length.....	29
5.3. Sidewall Termination .....	29
5.4. Installation Guidelines.....	30
5.5. Transition Boiler Air Piping to Manifold Guidelines .....	30
<b>CHAPTER 6 - COMMONWEALTH OF MASSACHUSETTS INSTALLATION REQUIREMENTS.....</b>	<b>31</b>
6.1. Installation of Carbon Monoxide Detectors. ....	31
6.2. Approved Carbon Monoxide Detectors. ....	31
6.3. Signage .....	31
6.4. Inspection. ....	32
6.4.1 Exemptions .....	32
6.4.2 Manufacturer Requirements - Gas Equipment Venting System Provided. ....	32
6.4.3 Manufacturer Requirements - Gas Equipment Venting System Not Provided. ....	32

## INDEX OF ILLUSTRATIONS

---

Fig. 1 - Direct Vent - Vertical Termination of Vent and Combustion Air Piping.....	12
Fig. 2 - Termination Clearances of Direct Vent System .....	13
Fig. 3 - Vertical Vent Bird Screen Installation .....	14
Fig. 4 - Vertical Combustion Air Bird Screen Installation .....	14
Fig. 5 - Direct Vent - Vertical Termination of Multiple GALLANT Boilers .....	14
Fig. 6 - Direct Vent - Sidewall Termination of Vent and Combustion Air Piping.....	17
Fig. 7 - Direct Vent - Alternate Sidewall Termination of Vent and Combustion Air Piping .....	17
Fig. 8 - Direct Vent - Sidewall Snorkel Termination of Vent and Combustion Air Piping.....	17
Fig. 9 - Sidewall Vent Bird Screen Installation .....	18
Fig. 10 - Sidewall Combustion Air Bird Screen Installation .....	18
Fig. 11 - Direct Vent - Sidewall Termination of Multiple GALLANT Boilers .....	19
Fig. 12 - Direct Vent - Vertical Vent and Side Wall Combustion Air Terminations.....	19
Fig. 13 - Direct Vent - Vertical Vent and Sidewall Combustion Air Terminations of Multiple GALLANT Boilers .....	20
Fig. 14 - Category - IV - Vertical Termination of Vent Pipe.....	21
Fig. 15 - Termination Clearances of Category IV System.....	22
Fig. 16 - Category IV- Vertical Termination of Multiple GALLANT Boilers.....	23
Fig. 17 - Category IV - Sidewall Termination of Vent Pipe .....	24
Fig. 18 - Category IV - Sidewall Snorkel Termination of Vent Pipe.....	24
Fig. 19 - Category IV - Sidewall Termination of Multiple GALLANT Boilers .....	25
Fig. 20 - 3 in. [80 mm] CPVC/PVC Venting System Vertical.....	26
Fig. 21 - 3 in. [80 mm] CPVC/PVC Venting System Horizontal.....	26

## INDEX OF TABLES

Table 1 - Maximum Allowable Vent or Combustion Air Piping Length.....	2
Table 2 - Approved Stainless Steel Vent Adapters and Terminations .....	3
Table 3 - Approved 3 in. [80 mm] Rigid Polypropylene Components .....	4
Table 4 - Approved 4 in. [100 mm] Rigid Polypropylene Components .....	5
Table 5 - Approved 3 in. [80 mm] Flex Polypropylene Components .....	6
Table 6 - Approved 4 in. [100 mm] Flex Polypropylene Components .....	7

## PRODUCT AND SAFETY INFORMATION

### DEFINITIONS

The following terms are used throughout this manual to bring attention to the presence of potential hazards or to important information concerning the product.



**Indicates the presence of a hazardous situation which, if ignored, will result in substantial property damage, serious injury, or death.**



**Indicates a potentially hazardous situation which, if ignored, can result in substantial property damage, serious injury, or death.**



**Indicates a potentially hazardous situation which, if ignored, can result in minor property damage or injury.**

### NOTICE

*Indicates special instructions on installation, operation or maintenance, which are important to the equipment but not related to personal injury hazards.*

### BEST PRACTICE

*Indicates recommendations made by Ideal for the installers which will help to ensure optimum operation and longevity of the equipment.*

### HOMEOWNER

- This manual is intended for use by a qualified heating contractor or service technician.
- Please refer to the User Information manual for additional information.
- Ensure this document and all pertaining documents are kept near the boiler to be used by the qualified heating contractor or service technician for future reference.

### INSTALLER



**Read all instructions as outlined in this manual and in the boiler installation manual. Failure to comply with these instructions in the order presented can result in substantial property damage, serious injury, or death.**

This document is a supplement to the GALLANT Boiler Installation and Maintenance manual. The purpose of this supplement is to ensure the proper installation of the vent and combustion air piping to the boiler.

### NOTICE

*This vent supplement outlines Direct Vent and Category IV (Indoor Air) installations using PVC, CPVC, PP and SS materials. For other venting options (materials, terminations, etc.), contact Ideal Heating North America.*



- The installer must verify that at least one carbon monoxide alarm has been installed within a residential living space or home following the alarm manufacturer's instructions and applicable local codes before putting the appliance into operation.
- A byproduct of any gas fired appliance is carbon monoxide. Ideal Heating North America follows the recommended advice of CPSC and requires the installation of a minimum of two (2) carbon monoxide detectors with an alarm and battery back-up if hard wired; one in the mechanical room where the boiler is located and another installed in the area outside each sleeping area for all installations. Consult the local authority having jurisdiction for any additional carbon monoxide detector requirements in your area. See *Chapter 6 on page 31* for additional carbon monoxide detector requirements in Massachusetts.
- All GALLANT vent and combustion air piping must be installed, terminated and joints sealed as outlined in this manual. Failure to comply with installation procedures outlined in this manual can result in substantial property damage, serious injury, or death.

### NOTICE

*Ideal Heating North America reserves the right to modify the technical specifications and components of its products without prior notice. Check for an updated version of this manual at [www.idealheatingna.com](http://www.idealheatingna.com).*

# CHAPTER 1 - PRE-INSTALLATION REQUIREMENTS

## 1.1. Removal of an Existing Boiler from a Common Vent System



**Do not install the GALLANT into a common vent with any other gas or oil appliances. This will cause flue gas spillage or appliance malfunction, resulting in substantial property damage, serious injury, or death.**

When an existing boiler is removed from a common venting system, the common venting system is likely to be too large for proper venting of the remaining appliances. At the time of removal of an existing boiler, the following steps shall be followed with each appliance remaining connected to the common venting system placed in operation, while the other appliances remaining connected to the common venting system are not in operation.

1. Seal any unused openings in the common venting system.
2. Visually inspect the venting system for proper size and horizontal pitch and determine there is no blockage or restriction, leakage, corrosion and other deficiencies which could cause an unsafe condition.
3. Insofar as is practical close all building doors and windows and all doors between the space in which the appliances remaining connected to the common venting system are located and other spaces of the building. Turn on clothes dryers and any appliance not connected to the common venting system. Turn on any exhaust fans, such as range hoods and bathroom exhausts, so they will operate at maximum speed. Do not operate a summer exhaust fan. Close fireplace dampers.
4. Place in operation the appliance being inspected. Follow the lighting instructions. Adjust thermostat so appliance will operate continuously.
5. Test for spillage at the draft hood relief opening after 5 minutes of main burner operation. Use the flame of a match or candle, or smoke from a cigarette, cigar or pipe.
6. After it has been determined that each appliance remaining connected to the common venting system properly vents when tested as outlined above, return doors, windows, exhaust fans, fireplace dampers and any other gas-burning appliance to their previous condition of use.

7. Any improper operation of the common venting system should be corrected so the installation conforms with the National Fuel Gas Code, ANSI Z223.1/NFPA 54 and/or CAN/CSA B149.1, Installation Codes. When resizing any portion of the common venting system, the common venting system should be resized to approach the minimum size as determined using the appropriate tables in Part 11 of the National Fuel Gas Code, ANSI Z223.1/NFPA 54 and/or CAN/CSA B149.1, Installation Codes.

## 1.2. Vent/Combustion Air Piping and Materials

### NOTICE

*The installation must conform to the requirements of the authority having jurisdiction or, in the absence of such requirements, to the National Fuel Gas Code, ANSI Z223.1/NFPA 54, and/or Natural Gas and Propane Installation Code, CAN/CSA B149.1.*

The GALLANT is certified per ANSI Z21.13 as a Category IV (indoor air) or Direct Vent (sealed combustion) appliance. A Category IV appliance utilizes uncontaminated indoor or outdoor air (surrounding the appliance) for combustion. A Direct Vent appliance utilizes uncontaminated outdoor air (piped directly to the appliance) for combustion.

### BEST PRACTICE

*To reduce the potential risks associated with indoor contaminants (listed on page 11), flammable vapors and tight housing construction (little or no infiltration air), it is recommended to pipe uncontaminated combustion air directly from the outdoors to the appliance. This practice also promotes higher system efficiency by reducing heated indoor air from being exhausted from the building and replaced by cold infiltration air.*

The GALLANT requires a Category IV venting system which is designed for pressurized venting and condensate.



**The vent and combustion air materials (piping, fittings and cement) must meet the listed requirements in this manual. Failure to comply with these material requirements can result in substantial property damage, serious injury, or death.**



## CHAPTER 1 - PRE-INSTALLATION REQUIREMENTS

### 1.2.1 PVC and CPVC Vent and Combustion Air Piping and Fittings

- PVC Schedule 40 - ANSI/ASTM D1785
- PVC-DWW - ANSI/ASTM D2665
- CPVC Schedule 40 - ANSI/ASTM F441

### 1.2.2 PVC and CPVC Pipe Cement and Primer

- PVC - ANSI/ASTM D2564
- CPVC - ANSI/ASTM F493

#### NOTICE

- *For installations in Canada, all piping, fittings and cement/primer material must be certified and listed to ULC-S636. Ipex Inc. is an approved manufacturer of ULC S636 vent components.*
- *Use of cellular core PVC (ASTM F891) cellular core CPVC, or Radel® (polyphenolsulfone) in venting systems is prohibited. Cellular core pipe may be used for combustion air piping.*



**DO NOT mix a PVC/CPVC vent system & components with other vent system materials & components. Seal all PVC and CPVC pipe and fittings with the appropriate primer and cement. Failure to comply with this requirement can cause the venting system to fail resulting in substantial property damage, serious injury, or death.**

### 1.2.3 AL29-4C® Stainless Steel Vent Piping and Fittings

Approved AL29-4C® Stainless Steel vent manufacturers and vent systems:

- SelKirk/Heatfab
- Dura Vent
- Z-FLEX U.S. Inc.

Only use approved stainless steel vent adapters and terminations listed in *Table 2 on page 3*.



**Contact approved AL29-4C® stainless steel vent manufacturer for a copy of their installation instructions. Read, understand and follow all of the vent manufacturer's instructions before beginning the installation. Contact vent manufacturer if you require any technical support. Failure to properly install and support vent system can cause the venting system to fail, resulting in substantial property damage, serious injury, or death.**

#### NOTICE

- *A specific vent adapter is required to transition from the boiler vent outlet adapter to specific stainless steel vent system. Contact the appropriate AL29-4C® vent manufacturer for transition adapter information.*
- *When using stainless steel for the vent system, PVC or CPVC pipe meeting the listed requirements in this manual may be utilized for the combustion air piping.*

### 1.2.4 Polypropylene (PP) Vent Piping and Fittings

Approved polypropylene vent manufacturers and vent systems:

- Centrotherm Eco Systems, LLC
- Dura Vent
- Z-Flex U.S. Inc.
- ECCO Manufacturing

Only use approved polypropylene components listed in *Table 2 on page 4* to *Table 4 on page 6*. Termination must be selected from the options shown in this manual, using UV-resistant polypropylene.



**Contact approved polypropylene vent manufacturer for a copy of their installation instructions. Read, understand and follow all of the vent manufacturer's instructions before beginning the installation. Contact vent manufacturer if you require any technical support. Failure to properly install and support vent system can cause the venting system to fail, resulting in substantial property damage, serious injury, or death.**

## NOTICE

- A specific vent adapter may be required to transition from the boiler vent outlet adapter to the specific polypropylene vent system. Contact the appropriate PP vent manufacturer for transition adapter information.
- When using Polypropylene for the vent system, PVC or CPVC pipe meeting the listed requirements in this manual may be utilized for the combustion air piping.

### 1.3. Vent/Combustion Air Equivalent Lengths

- For all venting applications, PVC/CPVC, AL29-4C®, SS or Polypropylene, the length must not exceed the lengths listed in *Table 5 below*.
- For PVC/CPVC or AL29-4C® vent systems, reduce the maximum allowable length for each elbow as follows:
  - 3 ft. [0.9 m] for every 45° elbow
  - 5 ft. [1.5 m] for every 90° elbow
- For polypropylene vent systems, reduce the maximum allowable length for each elbow as follows:
  - 5 ft. [1.5 m] for every 45° elbow
  - 10 ft. [3 m] for every 90° elbow

### 1.4. Vent Restrictions

#### 1.4.1 3 Inch [80 mm] Vent System Restrictions

Derate the maximum boiler input of the GALLANT 250 by 3% when using the maximum equivalent length of 3 in. [80 mm] vent piping.

#### 1.4.2 Rigid Polypropylene Vent System Restrictions



**Contact approved polypropylene vent manufacturer for a copy of their installation instructions. Read, understand and follow all of the vent manufacturer's instructions before beginning the installation. Contact vent manufacturer if you require any technical support. Failure to properly install and support vent system can cause the venting system to fail, resulting in substantial property damage, serious injury, or death.**

- Rigid polypropylene vent pipe must be installed with approved locking band clamps or connector rings and supports (wall strap or clamp, elbow or base, etc.). Consult vent manufacturer for complete list of required parts.
- Maintain 5/8 in. [1.5 cm] per ft. slope back toward appliance on all horizontal runs.
- The use of a wall plate is required to seal rigid polypropylene vent pipe at the entrance of the chimney or chase to prevent mortar or cement from contacting the polypropylene vent pipe.
- Any termination piping external to the building must be UV resistant.
- Do not apply insulation directly to vent. Maintain vent manufacturers clearances to combustibles.
- Plastic venting systems shall not pass through rated fire separations without approved fire stopping installed in accordance with fire stopping manufacturers instructions.
- Prior to assembly of any joints, ensure joint gasket is present and properly installed. Contact vent manufacturer if gasket is missing or damaged. Verify the integrity of joints upon completion of the vent system.

Table 1 - Maximum Allowable Vent or Combustion Air Piping Length

GALLANT Model	3 Inch [80 mm] Piping		OR	4 Inch [100 mm] Piping	
	Feet [m]	Elbows		Feet [m]	Elbows
250	60 [18]	0		80 [24]	0
299	Not Applicable			100 [30.5]	0
399				100 [30.5]	0



## CHAPTER 1 - PRE-INSTALLATION REQUIREMENTS

### 1.4.3 Flex Polypropylene Vent System Restrictions

- 4 in. [100 mm] Flex polypropylene venting is permitted on the GALLANT 250, 299 & 399.



**Contact approved polypropylene vent manufacturer for a copy of their installation instructions. Read, understand and follow all of the vent manufacturer's instructions before beginning the installation. Contact vent manufacturer if you require any technical support. Failure to properly install and support vent system can cause the venting system to fail, resulting in substantial property damage, serious injury, or death.**

- Approved for vertical installations only, where a clean, structurally sound unused chimney or chase is used as a raceway.
- Vertical offsets must not exceed 45° and are limited to a maximum number of 2.
- Requires rigid polypropylene vent pipe with approved locking band clamps or connector rings and wall straps or support clamps from the appliance to the entrance of the chimney or chase.
- Maintain 5/8 in. [1.5 cm] per ft. [30 cm] slope back toward appliance on all horizontal runs of rigid polypropylene vent pipe.

- The use of a wall plate is required to seal rigid polypropylene vent pipe at the entrance of the chimney or chase to prevent mortar or cement from contacting the polypropylene vent pipe.
- Requires supports (elbow or base, flex chimney and bracket), spacers, chimney cap and end pipe. Consult vent manufacturer for complete list of required parts.
- Any termination piping external to the building must be UV resistant.
- Do not apply insulation directly to vent. Maintain vent manufacturers clearances to combustibles.
- Flex plastic venting systems shall not pass through rated fire separations.
- Prior to assembly of any joints, ensure joint gasket is present and properly installed. Contact vent manufacturer if gasket is missing or damaged. Verify the integrity of joints upon completion of the vent system.

Description	Table 2 - Approved Stainless Steel Vent Adapters and Terminations		
	SelKirk / Heatfab Saf-T Vent EZ Seal or Saf-T Vent SC	DuraVent FasNSeal or CVS	Z-Flex U.S. Inc. Z-Vent
3 in. [80 mm] Vent Adapter	9301PVC	FSA-ULT3	2SVSTTA03
3 in. [80 mm] Roof & Side Wall Straight Termination	9392	300186	2SVSTPF03
3 in. [80 mm] Side Wall & 45° Elbow Termination	9311TERM	300130 & 300186	2SVSTEX0345
3 in. [80 mm] Side Wall Tee Termination	9390TEE	300311	2SVSTTF03
3 in. [80 mm] to 4 in. [100 mm] Vent Adapter	9401PVC3	FSA-ULT3*	2SVSTTA04
4 in. [100 mm] Vent Adapter	9401PVC	FSA-ULT4	SVSTTA04.5
4 in. [100 mm] Roof & Side Wall Straight Termination	9492	300187	2SVSTPF04
4 in. [100 mm] Side Wall & 45° Elbow Termination	9411TERM	300131 & 300187	2SVSTEX0445
4 in. [100 mm] Side Wall Tee Termination	9490TEE	300312	2SVSTTF04

# CHAPTER 1 - PRE-INSTALLATION REQUIREMENTS

*Table 3 - Approved 3 in. [80 mm] Rigid Polypropylene Components*

Description	Table 3 - Approved 3 in. [80 mm] Rigid Polypropylene Components			
	Centrotherm Eco Systems, LLC	Dura Vent	Z-Flex U.S. Inc.	ECCO Manufacturing
3 in. [80 mm] Appliance Vent Adapter	ISAAL0303	3PPS-03PVC3M-3PPF	2ZDCPVC3	3PPSSAD
3 in. [80 mm] Roof Termination - UV Resistant	ISEP03 (20 in. or 50 cm) or ISEP0339 (39 in. or 100 cm)	3PPS-12BC (12 in. or 30.5 cm) or 3PPS-36BC (36 in. or 91 cm)	2ZDP312UV (10 in. or 25 cm) or 2ZDP324UV (22 in. or 60 cm)	312PPPB (10 in. or 25 cm) or 324PPPB (22 in. or 60 cm)
3 in. [80 mm] Side Wall, 45° Elbow Termination - UV Resistant	ISELL0345UV	3PPS-E45BC	2ZDE345UV	345PELB
3 in. [80 mm] Side Wall, Tee Termination - UV Resistant	ISTT0320	3PPS-TBC	2ZDTT3	Not available
3 in. [80 mm] Side Wall Pipe Lengths - UV Resistant	ISVL032UV (24 in. or 61 cm)	3PPS-12BC (12 in. or 30.5 cm) or 3PPS-36BC (36 in. or 91 cm)	2ZDP312UV (10 in. or 25 cm) or 2ZDP324UV (22 in. or 60 cm)	312PPPB (10 in. or 25 cm) or 324PPPB (22 in. or 60 cm)
3 in. [80 mm] Side Wall, 90° Elbow - UV Resistant	ISELL0387UV	3PPS-E90BC or 3PPS-E90EBC	2ZDE387UV	387PELB
3 in. [80 mm] Bird Guard Screen - UV Resistant	IASPP03	3PPS-BG	2ZDES3	3PPWG
3 in. [80 mm] Locking Band Clamp or Connector Ring	IAN503	3PPS-LC	2ZDLC3	3PPLC
3 in. [80 mm] Wall Strap or Support Clamp	IASC03	3PPS-WSM1 (galvanized) or 3PPS-WSM-SS1 (stainless steel)	2ZDFB3	3PPB
3 in. [80 mm] Wall Plate	IAWP03BP	3PPS-WPB	2ZDWPB3	3PPWTK

# CHAPTER 1 - PRE-INSTALLATION REQUIREMENTS

*Table 4 - Approved 4 in. [100 mm] Rigid Polypropylene Components*

Description	Centrotherm Eco Systems, LLC				Dura Vent	Z-Flex U.S. Inc.	ECCO Manufacturing
	ISAAAL0303	ISIA0304 or ISEI0304	ISAAAL0404	ISEP04 (20 in. or 50 cm) or ISEP0439 (39 in. or 100 cm)			
3 in. [80 mm] Appliance Vent Adapter	ISAAAL0303				3PPS-03PVC-3PPF	2ZDCPVC3	3PPSSAD
3 in. [80 mm] to 4 in. [100 mm] Increaser		ISIA0304 or ISEI0304			3PPS-X4L	2ZDI34	304PINC
4 in. [100 mm] Appliance Vent Adapter		ISAAAL0404			4PPS-04PVC-4PPF	2ZDCPVC4	4PPSSAD
4 in. [100 mm] Roof Termination - UV Resistant		ISEP04 (20 in. or 50 cm) or ISEP0439 (39 in. or 100 cm)			4PPS-12BC (12 in. or 30.5 cm) or 4PPS-36BC (36 in. or 91 cm)	2ZDP412 (10 in. or 25 cm) or 2ZDP424 (22 in. or 60 cm)	412PPP (10 in. or 25 cm) or 424PPP (22 in. or 60 cm)
4 in. [100 mm] Side Wall, 45° Elbow Termination - UV Resistant		ISELL0445UV			4PPS-E45BC	2ZDE445UV	445PEL
4 in. [100 mm] Side Wall, Tee Termination - UV Resistant		ISTT0420			4PPS-TBC	2ZDTT4	Not available
4 in. [100 mm] Side Wall Pipe Lengths - UV Resistant		ISVL042UV (24 in. or 61 cm)			4PPS-12BC (12 in. or 30.5 cm) or 4PPS-36BC (36 in. or 91 cm)	2ZDP412 (10 in. or 25 cm) or 2ZDP424 (22 in. or 60 cm)	412PPP (10 in. or 25 cm) or 424PPP (22 in. or 60 cm)
4 in. [100 mm] Side Wall, 90° Elbow - UV Resistant		ISELL0487UV			4PPS-E90BC or 4PPS-E90EBC	2ZDE487UV	487PEL
4 in. [100 mm] Bird Guard Screen - UV Resistant		IASPP04			4PPS-BG	2ZDES4	4PPSSG
4 in. [100 mm] Locking Band Clamp or Connector Ring		IANS04			4PPS-LC	2ZDLC4	4PPLC
4 in. [100 mm] Wall Strap or Support Clamp		IASC04			4PPS-WSM1 (galvanized) or 4PPS-WSM-SS1 (stainless steel)	2ZDFB4	4PPB
4 in. [100 mm] Wall Plate		IAWP04BP			4PPS-WPB	Not available	Not available

# CHAPTER 1 - PRE-INSTALLATION REQUIREMENTS

*Table 5 - Approved 3 in. [80 mm] Flex Polypropylene Components*

Description	Centrotherm Eco Systems, LLC			
	Dura Vent	Z-Flex U.S. Inc.	ECCO Manufacturing	
3 in. [80 mm] Appliance Vent Adapter	3PPS-03PVC-3PPF	2ZDCPVC3	3PPSSAD	
3 in. [80 mm] Wall Plate	3PPS-WPB	Included in Flex Base Kit 2ZDFBK3	Not available	
3 in. [80 mm] Chimney Support Elbow or Base Support or Flex Base Kit	3PPS-SE90XC	2ZDFBK3	3PPELCS	
3 in. [80 mm] Support Bracket - Bottom of Chimney or Chase	PPS-SUP or 3PPS-SUP (Chimney)	Included in Flex Base Kit 2ZDFBK3	Included with Support Elbow 3PPELCS	
3 in. [80 mm] Support Bracket - Top of Chimney or Chase	3PPS-FSB	Included in Flex Chimney Liner Kit 2ZD2FLK3	3PPFFA	
3 in. [80 mm] Spacer	3PPS-S	Included in Flex Chimney Liner Kit 2ZD2FLK3	3PPFS	
3 in. [80 mm] Chimney Cap or Cover & End Pipe - UV Resistant or Flex Chimney Liner Kit	3PPS-FCTC	2ZD2FLK3	3PPFK	

# CHAPTER 1 - PRE-INSTALLATION REQUIREMENTS

*Table 6 - Approved 4 in. [100 mm] Flex Polypropylene Components*

Description	Centrotherm Eco Systems, LLC				ECCO Manufacturing
	Dura Vent	Z-Flex U.S. Inc.			
3 in. [80 mm] Appliance Vent Adapter	3PPS-03PVC-3PPF	2ZDCPVC3	3PPSSAD		3PPSSAD
3 in. [80 mm] to 4 in. [100 mm] Increaser	3PPS-X4L	2ZDI34	304PINC		304PINC
4 in. [100 mm] Appliance Vent Adapter	4PPS-04PVC-4PPF	2ZDCPVC4	4PPSSAD		4PPSSAD
4 in. [100 mm] Wall Plate	4PPS-WPB	Not available	Not available		Not available
4 in. [100 mm] Chimney Support Elbow or Base Support or Flex Base Kit	4PPS-SE90XC	2ZDFBK4	4PELCS		4PELCS
4 in. [100 mm] Support Bracket - Bottom of Chimney or Chase	PPS-SUP or 4PPS-SUP (Chimney)	Included in Flex Base Kit 2ZDFBK4	Included with Support Elbow 4PELCS		Included with Support Elbow 4PELCS
4 in. [100 mm] Support Bracket - Top of Chimney or Chase	4PPS-FSB	Included in Flex Chimney Liner Kit 2ZD2FLK4	4PPFFA		4PPFFA
4 in. [100 mm] Spacer	4PPS-S	Included in Flex Chimney Liner Kit 2ZD2FLK4	4PPFS		4PPFS
4 in. [100 mm] Chimney Cap or Cover & End Pipe - UV Resistant or Flex Chimney Liner Kit	4PPS-FCTC	2ZD2FLK4	4PPFK		4PPFK

\*100mm for Dura Vent

### 1.5. Combustion Air Contamination



If the GALLANT combustion air inlet is located in an area likely to cause or contain contamination, or if products which could contaminate the air cannot be removed, the combustion air must be repiped and terminated at another location. Contaminated combustion air will damage the unit and its burner system, and can result in substantial property damage, serious injury, or death.



- Do not operate the GALLANT if the combustion air inlet is located near a laundry room or pool facility. These areas will always contain hazardous contaminants.
- Pool, laundry, common household, and hobby products often contain fluorine or chlorine compounds. When these chemicals pass through the burner and vent system, they can form strong acids. These acids will corrode the heat exchanger, burner components, and vent system, causing serious damage and possible flue gas spillage or water leakage into the surrounding area.
- Please read the information listed on the right. If contaminating chemicals are located near the area of the combustion air inlet, the installer must pipe the combustion air inlet to an area free of these chemicals.
- Failure to comply with these instructions will result in substantial property damage, serious injury, or death

#### Potential contaminating products

- Spray cans containing chloro/fluorocarbons
- Permanent Wave Solutions
- Chlorinated wax
- Chlorine based swimming pool chemicals / cleaners
- Calcium Chloride used for thawing ice
- Sodium Chloride used for water softening
- Refrigerant leaks
- Paint or varnish removers
- Hydrochloric acid / muriatic acid
- Cements and glues
- Antistatic fabric softeners used in clothes dryers
- Chlorine-type bleaches, detergents, and cleaning solvents found in household laundry rooms
- Adhesives used to fasten building products and other similar products

#### Areas likely to contain these products

- Dry cleaning / laundry areas and establishments
- Beauty salons
- Metal fabrication shops
- Swimming pools and health spas
- Refrigeration Repair shops
- Photo processing plants
- Auto body shops
- Plastic manufacturing plants
- Furniture refinishing areas and establishments
- New building construction
- Remodeling areas
- Garages with workshops



## CHAPTER 2 - DIRECT VENT INSTALLATION OF VENT/AIR PIPING

### 2.1. Direct Vent - Vertical - Through the Roof or Unused Chimney

A Direct Vent appliance utilizes uncontaminated outdoor air (piped directly to the appliance) for combustion.

#### NOTICE

- *The installation must conform to the requirements of the authority having jurisdiction or, in the absence of such requirements, to the National Fuel Gas Code, ANSI Z223.1/ NFPA 54, and/or Natural Gas and Propane Installation Code, CAN/CSA B149.1.*
- *When using an inoperative chimney as a means of a chase for the vent, the surrounding space within the chimney cannot be used to draw combustion air or vent another appliance.*



**A gas vent extending through a roof must not terminate near an adjacent wall or below any building extensions such as roof eaves, balconies or decks. Failure to comply with the required clearances in this manual can result in substantial property damage, serious injury, or death.**

#### NOTICE

*The information and diagrams outlining the fittings and method of terminating the vent/combustion air are directly related to PVC/CPVC vent systems. When utilizing an AL29-4C® or Polypropylene vent system, there may be some variations. Consult the appropriate vent manufacturer for recommendations and clarifications.*

### 2.1.1 Determine Termination Location

Locate the vent and combustion air termination using the following guidelines:

1. The total length of the vent or combustion air piping must not exceed the limits given in *Table 5 on page 9*.

#### NOTICE

*Do not include the 90° elbows used to terminate the combustion air inlet exterior of the building when determining the total length of pipe.*

2. The combustion air piping must terminate in an upside down "U" shape fashion using two 90° elbows, as shown in *Fig. 1 on page 12*. The termination must be located 12 in. [30.5 cm] (18 in. [46 cm] Canada) above the highest anticipated snow level.
3. The vent piping must terminate vertically with a coupling to accept the bird screen and must be located 12 in. to 24 in. [30.5 cm to 61 cm] above the combustion air inlet as shown in *Fig. 1 on page 12*.
4. The vent and combustion air terminations must be located at a radial distance of 12 in. to 24 in. [30.5 cm to 61 cm] from centerline of vent termination to centerline of air termination as shown in *Fig. 1 on page 12*.
5. The following should be considered when determining the location of the vent and combustion air terminations:
  - a. Locate the vent termination where flue vapors will not damage surrounding shrubs, plants, air conditioning equipment or be objectionable to the homeowner.
  - b. The flue products will form a noticeable plume of water vapor as they condense in colder air. Avoid terminating the vent in areas where the plume could obstruct window views.
  - c. Prevailing winds could cause freezing of flue gas condensation and a buildup of water / ice on surrounding plants, building surfaces or combustion air inlet.
  - d. Avoid locations where prevailing winds could affect the performance of the boiler or cause recirculation of the flue gases, such as inside corners of buildings, near adjacent buildings, vertical surfaces, window wells, stairwells, alcoves, courtyards, or other recessed areas.

- e. Do not terminate the vent above doors or windows, flue condensate could freeze causing ice formations.
  - f. Locate the vent termination to prevent possible condensate damage to exterior finishes.
  - g. Avoid locations of possible accidental contact of flue vapors with people or pets.
6. The vent termination must also maintain the following clearances, as shown in *Fig. 2 on page 13*:
- a. At least 3 ft. [0.9 m] from adjacent walls
  - b. At least 3 ft. [0.9 m] below roof overhangs
  - c. At least 7 ft. [2.1 m] above any public walkways
  - d. At least 3 ft. [0.9 m] above any forced air intake within 10 ft. [3 m] (does not apply to the combustion air inlet of a direct vent appliance).
  - e. No closer than 12 in. [30.5 cm] below or horizontally from any door, window or gravity air inlet.
  - f. Must be at least 4 ft. [1.2 m] from any electric meters, gas meters-regulators, relief valves or other equipment. Never terminate the vent above or below any of these items within 4 ft. [1.2 m] horizontally.
  - g. A minimum 12 in. [30.5 cm] horizontal spacing from other fan assisted appliance vents. Never terminate the vent above or below any fan assisted vent within 12 in. [30.5 cm] horizontally.
7. Locate the vent and combustion air terminations in a manner to protect from damage by foreign objects, such as stones, balls, or buildup of leaves or sediment.
8. Do not connect any other appliance to the vent pipe or multiple boilers to a common vent pipe.

### 2.1.2 Direct Vent - Vent Installation - Through the Roof

1. Vent and Combustion Air Penetration
  - Vent pipe penetration through combustible or non-combustible wall material must maintain a minimum 1/4 in. [6 mm] clearance for 3 in. [80 mm] [80 mm] and 4 in. [100 mm] PVC/CPVC vent. The diameter of the penetration hole must be 4 in. [10.2 cm] minimum for 3 in. [80 mm] pipe or 5 in. [12.7 cm] minimum for 4 in. [100 mm] pipe. When using Polypropylene or Stainless Steel Vent refer to vent manufacturer's Installation Instructions for clearances.

- Combustion air pipe penetration can maintain zero clearance. The diameter of the penetration hole should be 3-1/2 in. [8.9 cm] minimum for 3 in. [80 mm] pipe or 4-1/2 in. [11.4 cm] minimum for 4 in. [100 mm] pipe.
2. The installer must use a galvanized metal thimble for the vent pipe penetration.
  3. Locate the vent and combustion air pipe penetrations to provide clearances as described in *Fig. 1 on page 12*.
  4. The installer must comply with all local codes for isolating the vent and combustion air pipes as they pass through floors, ceilings and roofs.
  5. The installer must provide adequate flashing and sealing boots sized for the vent pipe and combustion air pipe.

### 2.1.3 Termination Fittings - Through the Roof

1. The vent and combustion air terminations must include a factory supplied "bird screen" installed as shown in *Fig. 3* and *Fig. 4 on page 14*
2. The combustion air piping must terminate in an upside down "U" shape fashion using two 90° elbows as shown in *Fig. 1 on page 12*.
3. The vent piping must terminate vertically with a coupling as shown in *Fig. 1 on page 12*.



**Do not extend the vent pipe above the roof beyond the dimensions shown in *Fig. 1 on page 12*. Extended exposure of the vent pipe could cause condensate to freeze and block the vent pipe, resulting in substantial property damage, serious injury, or death**

### 2.1.4 Direct Vent - Multiple Boiler Installation - Through the Roof

1. On installations of multiple GALLANT boilers, terminate each vent and combustion air pipe as described in this manual.
2. The roof penetration of the vent and combustion air piping must be such that the combustion air inlet is a minimum 12 in. [30.5 cm] from the adjacent vent pipe of the other boiler for installations in the U.S. as shown in *Fig. 5 on page 14*. For installations in Canada, provide clearances as required by CAN/CSA B149.1.

### NOTICE

*The combustion air inlet of the GALLANT is defined as being part of a direct vent system. It is not considered as a forced air intake. The required clearance of an adjacent boiler vent to a forced air inlet does not apply in a multiple installation of GALLANT boilers.*

### 2.2. Direct Vent - Horizontal - Sidewall

#### NOTICE

- *The installation must conform to the requirements of the authority having jurisdiction or, in the absence of such requirements, to the National Fuel Gas Code, ANSI Z223.1/ NFPA 54, and/or Natural Gas and Propane Installation Code, CAN/CSA B149.1.*
- *For sidewall vented installations in the Commonwealth of Massachusetts, the installer must comply with the additional requirements outlined in Chapter 6 on page 31.*



**A gas vent extending through a sidewall must not terminate near an adjacent wall or below any building extensions such as roof eaves, balconies or decks. Failure to comply with the required clearances in this manual can result in substantial property damage, serious injury, or death.**

#### NOTICE

*The information and diagrams outlining the fittings and method of terminating the vent/ combustion air are directly related to PVC/ CPVC vent systems. When utilizing an AL29-4C® or Polypropylene vent system, there may be some variations. Consult the appropriate vent manufacturer for recommendations and clarifications.*

### 2.2.1 Determine Termination Location

Locate the vent and combustion air termination using the following guidelines:

1. The total length of the vent or combustion air piping must not exceed the limits given in *Table 5 on page 9*.

#### NOTICE

*Do not include the 90° elbows used to terminate the combustion air inlet and vent exterior of the building when determining the total length of pipe.*

2. The combustion air piping must terminate using a 90° elbow directed away from the vent termination. The termination must be located 12 in. [30.5 cm] minimum above grade / highest anticipated snow level as shown in *Fig. 6 to Fig. 8 on page 17*.

#### NOTICE

*The combustion air termination can be placed on either side of the vent termination. The vent and combustion air terminations must be a minimum 12 in. [30.5 cm] apart horizontally and vertically. The vent and combustion air terminations are not required to be in the same pressure zone. The combustion air termination must be directed away from the vent for *Fig. 8 on page 17*. The combustion air termination must be directed down for *Fig. 6 and Fig. 7 on page 17*.*

3. The vent piping can terminate:
  - Using a 90° elbow as shown in *Fig. 6 or Fig. 8 on page 17*.
  - Using a coupling as shown in *Fig. 7 on page 17*.
  - The vent termination must be located 12 in. [30.5 cm] minimum above the combustion air termination.
4. The combustion air and vent pipe center lines must be a minimum of 12 in. [30.5 cm] apart as shown in *Fig. 6 through Fig. 8 on page 17*.
5. The following should be considered when determining the location of the vent and combustion air terminations:
  - a. Locate the vent termination where flue vapors will not damage surrounding shrubs, plants, air conditioning equipment or be objectionable to the homeowner.

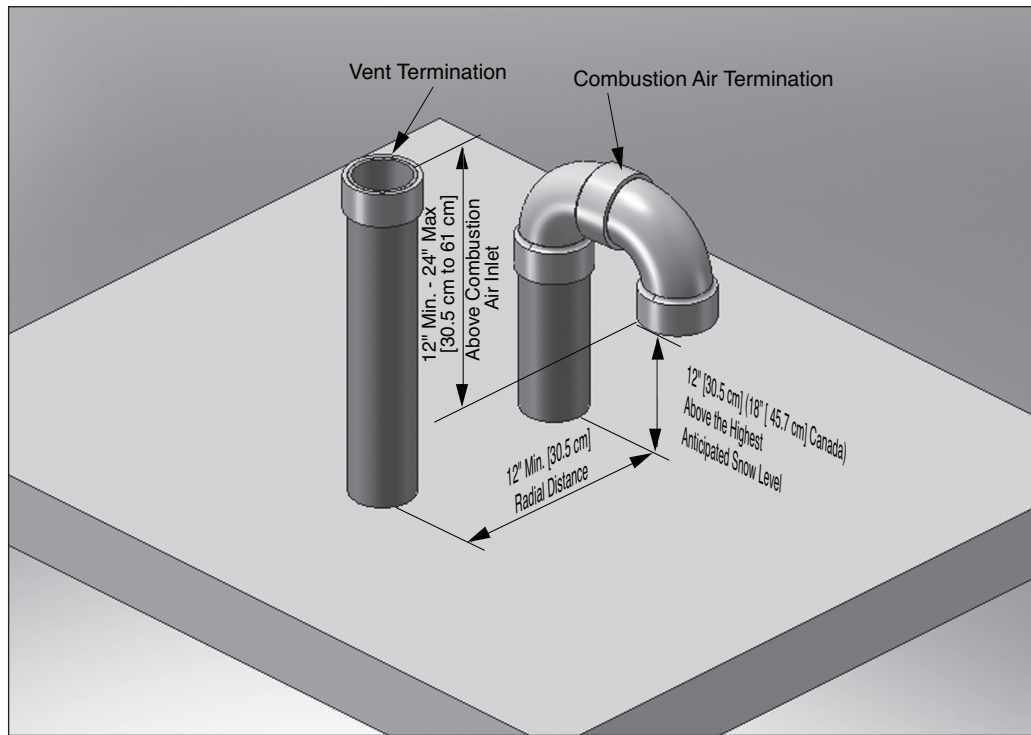

Fig. 1 - Direct Vent - Vertical Termination of Vent and Combustion Air Piping.

- b. The flue products will form a noticeable plume of water vapor as they condense in colder air. Avoid terminating the vent in areas where the plume could obstruct window views.
  - c. Prevailing winds could cause freezing of flue gas condensation and a buildup of water / ice on surrounding plants, building surfaces or combustion air inlet.
  - d. Avoid locations where prevailing winds could affect the performance of the boiler or cause recirculation of the flue gases, such as inside corners of buildings, near adjacent buildings, vertical surfaces, window wells, stairwells, alcoves, courtyards, or other recessed areas.
  - e. Do not terminate the vent above doors or windows, flue condensate could freeze causing ice formations.
  - f. Locate the vent termination to prevent possible condensate damage to exterior finishes.
  - g. Avoid locations of possible accidental contact of flue vapors with people or pets.
6. The vent termination must also maintain the following clearances; as shown in **Fig. 2 on page 13**.
- a. At least 3 ft. [0.9 m] from adjacent walls
  - b. At least 3 ft. [0.9 m] below roof overhangs
  - c. At least 7 ft. [2.1 m] above any public walkways
  - d. At least 3 ft. [0.9 m] above any forced air intake within 10 ft. [3 m] (does not apply to the combustion air inlet of a direct vent appliance).
  - e. No closer than 12 in. [30.5 cm] below or horizontally from any door, window or gravity air inlet.
  - f. Must be at least 4 ft. [1.2 m] from any electric meters, gas meters-regulators, relief valves or other equipment. Never terminate the vent above or below any of these items or within 4 ft. [1.2 m] horizontally.
  - g. A minimum of 12 in. [30.5 cm] or a maximum of 24 in. [61 cm] beyond the exterior wall.
  - h. A minimum 12 in. [30.5 cm] horizontal spacing from other fan assisted appliance vents. Never terminate the vent above or below any fan assisted vent within 12 in. [30.5 cm] horizontally.
7. The edge of the combustion air termination coupling must extend 1 in. [2.5 cm] beyond the exterior wall as shown in **Fig 6** through **Fig. 8 on page 17**.
8. Locate the vent and combustion air terminations in a manner to protect from damage by foreign objects, such as stones, balls, or buildup of leaves or sediment.
9. Do not connect any other appliance to the vent pipe or multiple boilers to a common vent pipe.

## CHAPTER 2 - DIRECT VENT INSTALLATION OF VENT/AIR PIPING

### 2.2.2 Direct Vent - Vent Installation - Sidewall

1. Vent and Combustion Air Penetration
  - Vent pipe penetration through combustible or non-combustible wall material must maintain a minimum 1/4 in. [6mm] clearance for 3 in. [80 mm] and 4 in. [100 mm] PVC/CPVC vent. The diameter of the penetration hole must be 4 in. [10.2 cm] minimum for 3 in. [80 mm] pipe or 5 in. [12.7 cm] minimum for 4 in. [100 mm] pipe. When using Polypropylene or Stainless Steel Vent refer to vent manufacturer's Installation Instructions for clearances.
  - Combustion air pipe penetration can maintain zero clearance. The diameter of the penetration hole should be 3-1/2 in. [8.9 cm] minimum for 3 in. [80 mm] pipe or 4-1/2 in. [11.4 cm] minimum for 4 in. [100 mm] pipe.
2. The installer must use a galvanized metal thimble for the vent pipe penetration.
3. Locate the vent and combustion air pipe penetrations to provide clearances as described in *Fig. 6* through *Fig. 8 on page 17*.
4. The installer must comply with all local codes for isolating the vent and combustion air pipes as they pass through floors and walls.
5. The installer must seal all exterior openings around penetration with an exterior silicon caulk.

### 2.2.3 Termination Fittings - Sidewall

The combustion air termination in the horizontal orientation may lead to rainwater getting into the piping under specific weather conditions. Therefore, all combustion air termination should be built with a 90° elbow pointing down toward the ground.

All affected installations should be adjusted so that the combustion air piping terminates with 180° bend with the intake opening facing the ground using two 90° elbows. The termination must be located 12 in. [30.5 cm] (18 in. [46 cm] in Canada) above the highest anticipated snow level.

1. The vent and combustion air terminations must include a factory supplied "bird screen" installed as shown in *Fig. 9* and *Fig. 10 on page 18*.
2. The combustion air piping must terminate using a 90° elbow as shown in *Fig. 6* through *Fig. 8 on page 17*.
3. The vent piping can terminate:
  - Using a 90° elbow as shown in *Fig. 6* or *Fig. 8 on page 17*.
  - Using a coupling as shown in *Fig. 7 on page 17*.

The vent termination must be installed 12 in. [30.5 cm] minimum above the combustion air termination.

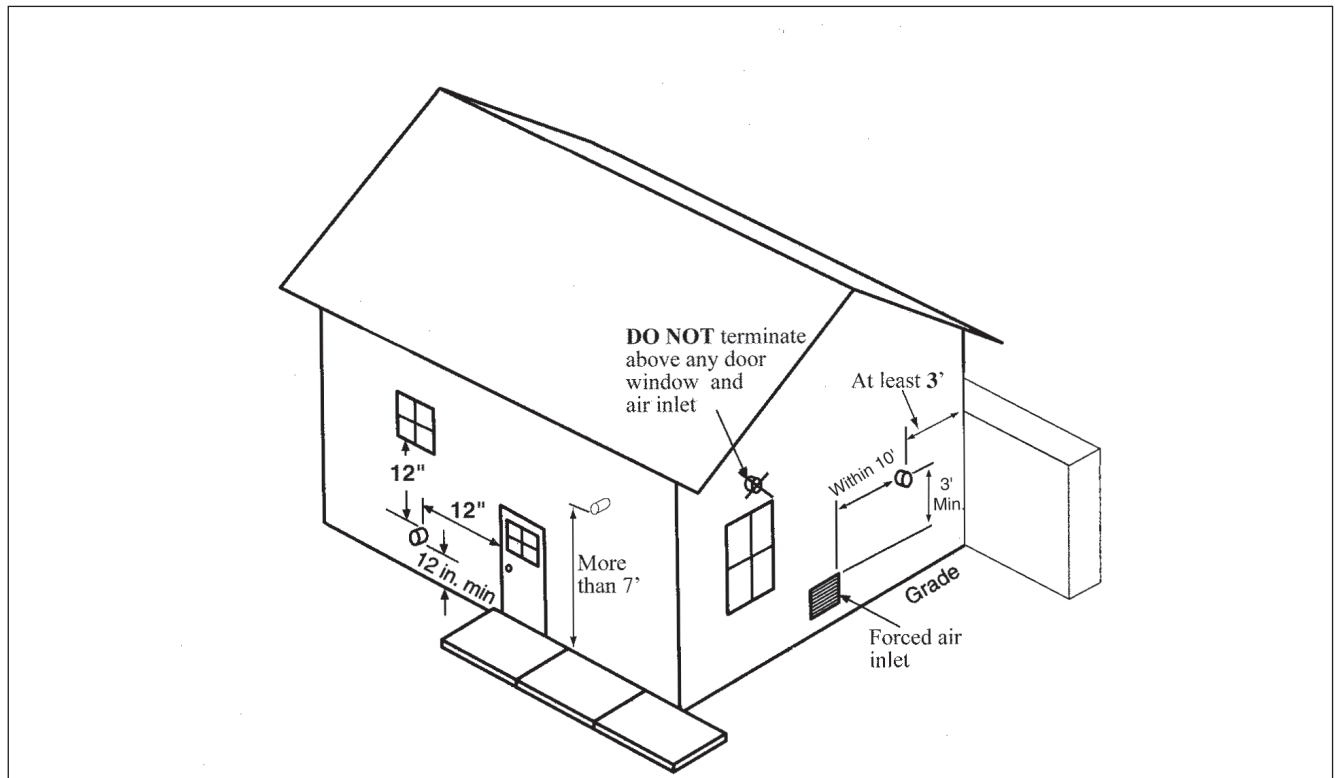

Fig. 2 - Termination Clearances of Direct Vent System



## CHAPTER 2 - DIRECT VENT INSTALLATION OF VENT/AIR PIPING

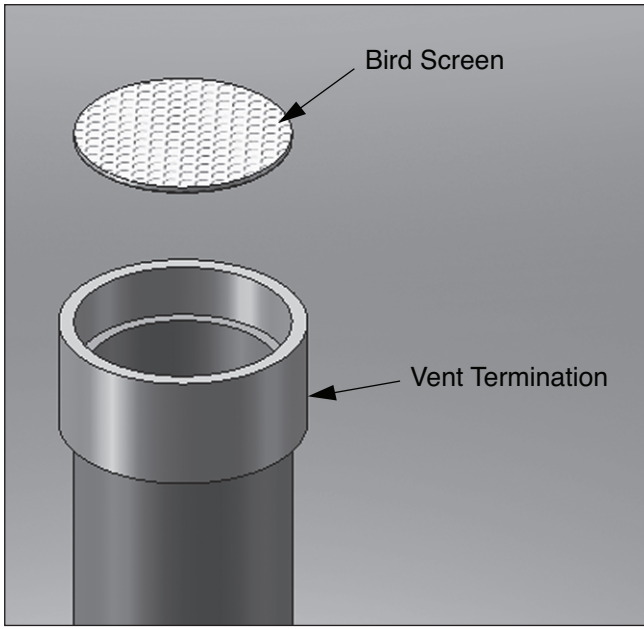

Fig. 3 - Vertical Vent Bird Screen Installation

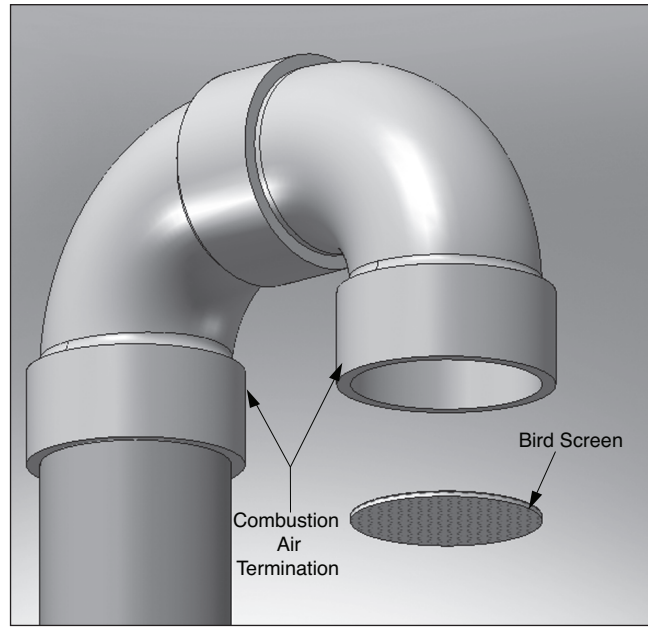

Fig. 4 - Vertical Combustion Air Bird Screen Installation

### NOTICE

The installer must install the factory supplied "bird screens" on the vent and combustion air terminations.

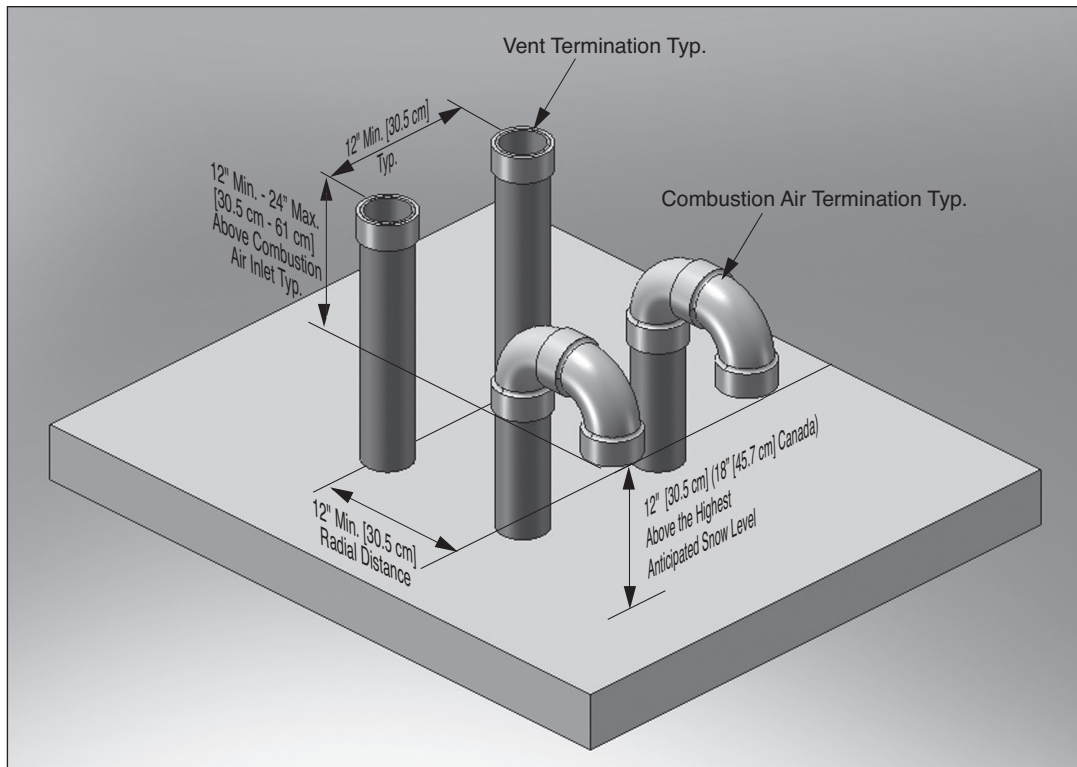

Fig. 5 - Direct Vent - Vertical Termination of Multiple GALLANT Boilers





Do not extend the vent pipe outside the sidewall beyond the dimensions shown in Fig. 6 through Fig. 8 on page 17. Extended exposure of the vent pipe could cause condensate to freeze and block the vent pipe, resulting in substantial property damage, serious injury, or death.

### 2.2.4 Direct Vent - Multiple Boiler Installation - Sidewall

1. On installations of multiple GALLANT boilers, terminate each vent and combustion air pipe as described in this manual.
2. The wall penetration of the vent and combustion air piping must be such that the combustion air inlet is a minimum 12 in. [30.5 cm] from the adjacent vent pipe of the other boiler for installations in the U.S as shown in *Fig. 11 on page 19*. For installations in Canada, provide clearances as required by CAN/CSA B149.1.

### NOTICE

*The combustion air inlet of the GALLANT is defined as being part of a direct vent system. It is not considered as a forced air intake. The required clearance of an adjacent boiler vent to a forced air inlet does not apply in a multiple installation of GALLANT boilers.*

### NOTICE

- *Fig. 11 on page 19 shows one option for vent and combustion air terminations of multiple GALLANT boilers. Either termination option shown in Fig 6 or Fig. 7 on page 17 can be used for multiple GALLANT boilers. The 12 in. [30.5 cm] minimum distance between centerlines of the combustion air and vent piping must be maintained for any chosen option.*
- *Refer to Fig. 6 or Fig. 7 on page 17 for the vent and combustion air inlet termination dimensions for each unit installed in a multiple installation.*

### 2.3. Direct Vent - Vertical Vent and Sidewall Combustion Air

### NOTICE

- *The installation must conform to the requirements of the authority having jurisdiction or, in the absence of such requirements, to the National Fuel Gas Code, ANSI Z223.1/ NFPA 54, and/or Natural Gas and Propane Installation Code, CAN/CSA B149.1.*
- *When using an inoperative chimney as a means of a chase for the vent, the surrounding space within the chimney cannot be used to draw combustion air or vent another appliance.*



**A gas vent extending through a roof must not terminate near an adjacent wall or below any building extensions such as roof eaves, balconies or decks. Failure to comply with the required clearances in this manual can result in substantial property damage, serious injury, or death.**

### NOTICE

*The information and diagrams outlining the fittings and method of terminating the vent/combustion air are directly related to PVC/CPVC vent systems. When utilizing an AL29-4C® or Polypropylene vent system, there may be some variations. Consult the appropriate vent manufacturer for recommendations and clarifications.*

## CHAPTER 2 - DIRECT VENT INSTALLATION OF VENT/AIR PIPING

### 2.3.1 Determine Termination Location

Locate the vent and combustion air termination using the following guidelines:

1. The total length of the vent or combustion air piping must not exceed the limits given in **Table 5 on page 9**.

#### **NOTICE**

***Do not include the 90° elbows used to terminate the combustion air inlet exterior of the building when determining the total length of pipe.***

2. The combustion air piping must terminate with a 90° elbow. **Fig. 12 on page 19** shows a snorkel termination option. The combustion air pipe can also terminate using a 90° elbow directed down as shown in **Fig. 6 on page 17**. The termination must be located 12 in. [30.5 cm] minimum above grade / highest anticipated snow level.
3. The vent piping must terminate vertically with a coupling to accept the bird screen and must be located 12 in. [30.5 cm] (18 in. [45.7 cm] Canada) above the highest anticipated snow level.
4. The following should be considered when determining the location of the vent and combustion air terminations:
  - a. Locate the vent termination where flue vapors will not damage surrounding shrubs, plants, air conditioning equipment or be objectionable to the homeowner.
  - b. The flue products will form a noticeable plume of water vapor as they condense in colder air. Avoid terminating the vent in areas where the plume could obstruct window views.
  - c. Prevailing winds could cause freezing of flue gas condensation and a buildup of water / ice on surrounding plants, building surfaces or combustion air inlet.
  - d. Avoid locations where prevailing winds could affect the performance of the boiler or cause recirculation of the flue gases, such as inside corners of buildings, near adjacent buildings, vertical surfaces, window wells, stairwells, alcoves, courtyards, or other recessed areas.
  - e. Do not terminate the vent above doors or windows, flue condensate could freeze causing ice formations.
  - f. Locate the vent termination to prevent possible condensate damage to exterior finishes.
  - g. Avoid locations of possible accidental contact of flue vapors with people or pets.
5. The vent termination must also maintain the following clearances; as shown in **Fig. 2 on page 13**.
  - a. At least 3 ft. [0.9 m] from adjacent walls
  - b. At least 3 ft. [0.9 m] below roof overhangs
  - c. At least 7 ft. [2.1 m] above any public walkways
  - d. At least 3 ft. [0.9 m] above any forced air intake within 10 ft. [3 m] (does not apply to the combustion air inlet of a direct vent appliance).
  - e. No closer than 12 in. [30.5 cm] below or horizontally from any door or window or gravity air inlet.
  - f. Must be at least 4 ft. [1.2 m] from any electric meters, gas meters-regulators, relief valves or other equipment. Never terminate the vent above or below any of these items within 4 ft. [1.2 m] horizontally.
  - g. A minimum 12 in. [30.5 cm] horizontal spacing from other fan assisted appliance vents. Never terminate the vent above or below any fan assisted vent within 12 in. [30.5 cm] horizontally.
6. The edge of the combustion air termination coupling must extend 1 in. [2.5 cm] beyond the exterior wall as shown in **Fig. 12 on page 19**.
7. Locate the vent and combustion air terminations in a manner to protect from damage by foreign objects, such as stones, balls, or buildup of leaves or sediment.
8. Do not connect any other appliance to the vent pipe or multiple boilers to a common vent pipe.

## CHAPTER 2 - DIRECT VENT INSTALLATION OF VENT/AIR PIPING

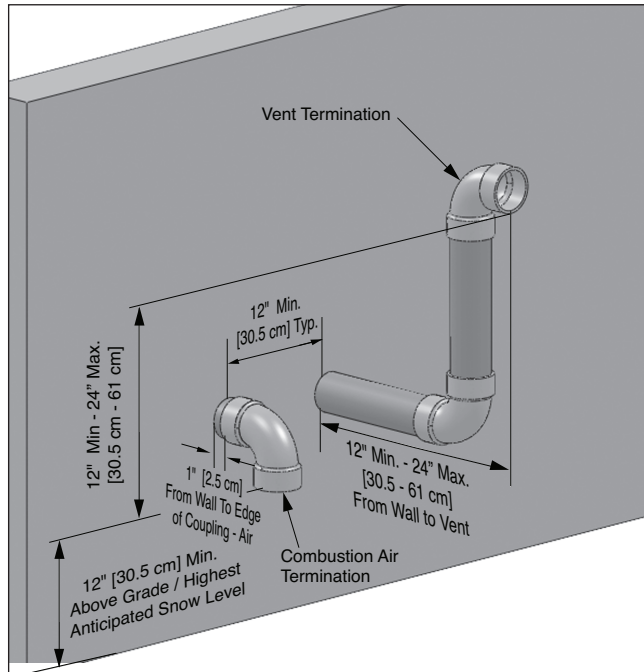

Fig. 6 - Direct Vent - Sidewall Termination of Vent and Combustion Air Piping

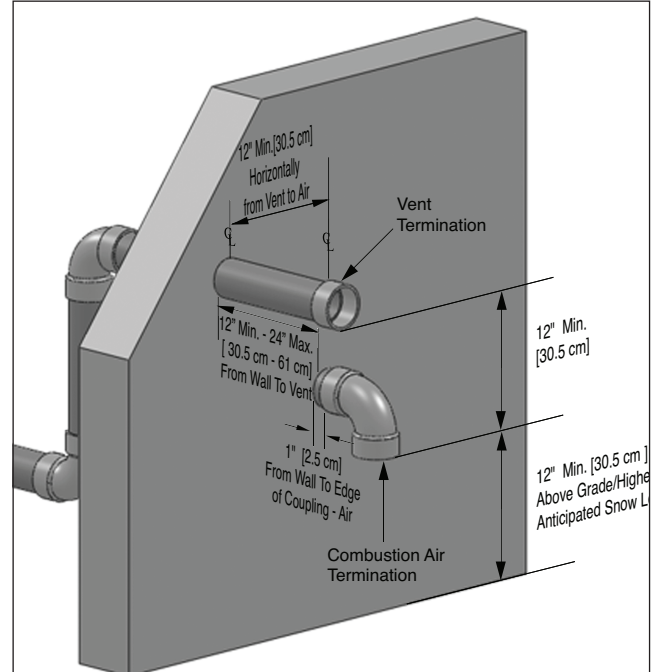

Fig. 7 - Direct Vent - Alternate Sidewall Termination of Vent and Combustion Air Piping

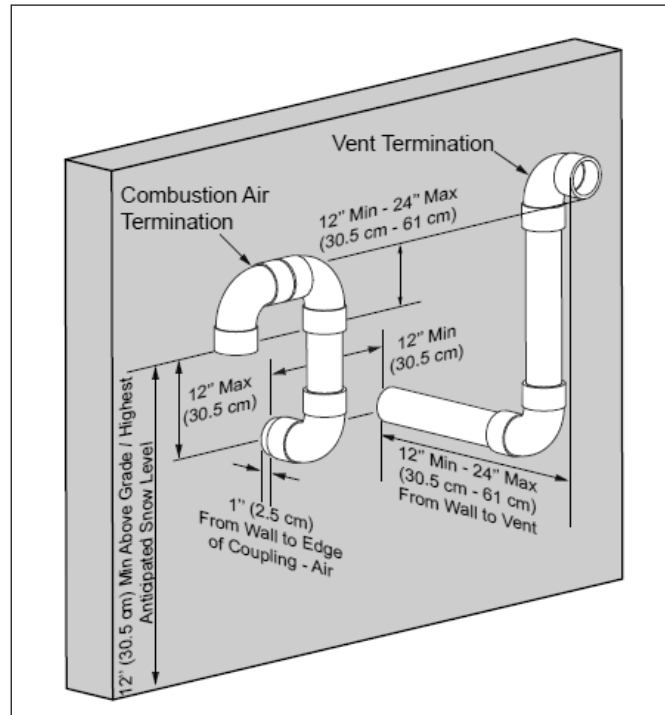

Fig. 8 - Direct Vent - Sidewall Snorkel Termination of Vent and Combustion Air Piping

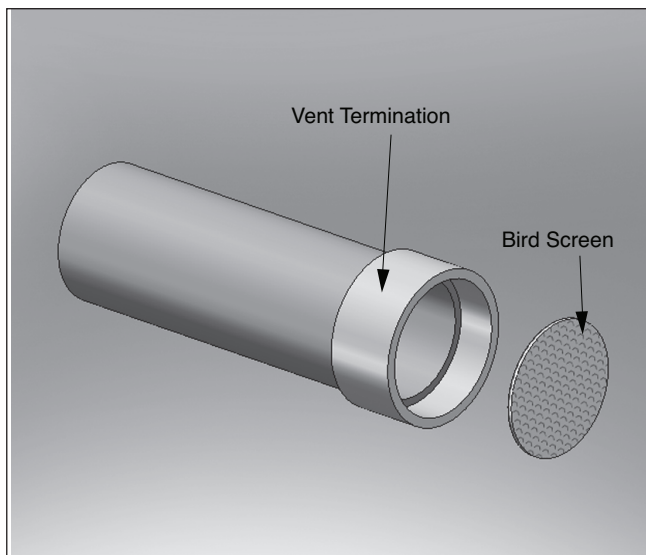

Fig. 9 - Sidewall Vent Bird Screen Installation

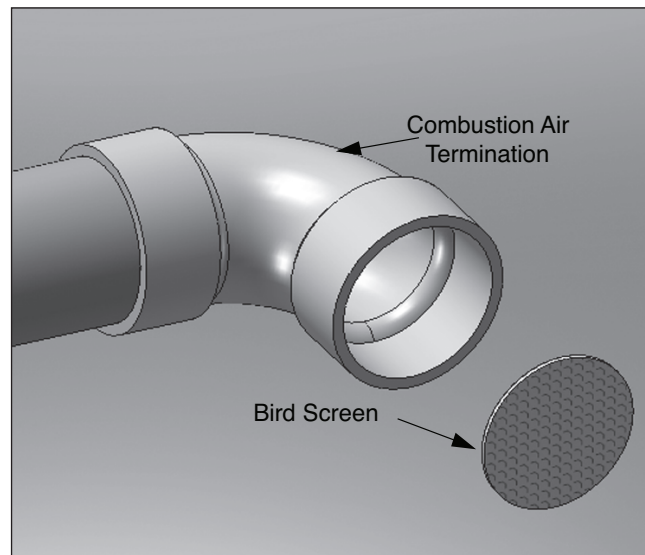

Fig. 10 - Sidewall Combustion Air Bird Screen Installation

### NOTICE

*The installer must install the factory-supplied "bird screens" on the vent and combustion air terminations.*

#### 2.3.2 Direct Vent - Vent Installation - Through the Roof

1. Vent pipe penetration through combustible or non-combustible wall material must maintain a minimum 1/4 in. [6 mm] clearance for 3 in. [80 mm] and 4 in. [100 mm] PVC/CPVC vent. The diameter of the penetration hole must be 4 in. [10.2 cm] minimum for 3 in. [80 mm] pipe or 5 in. [12.7 cm] minimum for 4 in. [100 mm] pipe. When using Polypropylene or Stainless Steel Vent refer to vent manufacturer's Installation Instructions for clearances.
2. The installer must use a galvanized metal thimble for the vent pipe penetration.
3. The vent must terminate 12 in. [30.5 cm] (18 in. [46 cm] Canada) above the highest anticipated snow level.
4. The installer must comply with all local codes for isolating the vent pipe as it passes through floors, ceilings and roofs.
5. The installer must provide adequate flashing and sealing boots sized for the vent pipe.

#### 2.3.3 Direct Vent - Combustion Air Installation - Sidewall

1. Combustion air pipe penetration can maintain zero clearance. The diameter of the penetration hole should be 3 1/2 in. [8.9 cm] minimum for 3 in. [80 mm] pipe or 4 1/2 in. [11.4 cm] minimum for 4 in. [100 mm] pipe.
2. The combustion air termination must be installed 12 in. [30.5 cm] minimum above grade / highest anticipated snow level as shown in *Fig. 6 or Fig. 8 on page 17*.
3. The installer must comply with all local codes for isolating the combustion air pipe as it passes through floors and walls.
4. The installer must seal all exterior openings around penetration with an exterior silicon caulk.

## CHAPTER 2 - DIRECT VENT INSTALLATION OF VENT/AIR PIPING

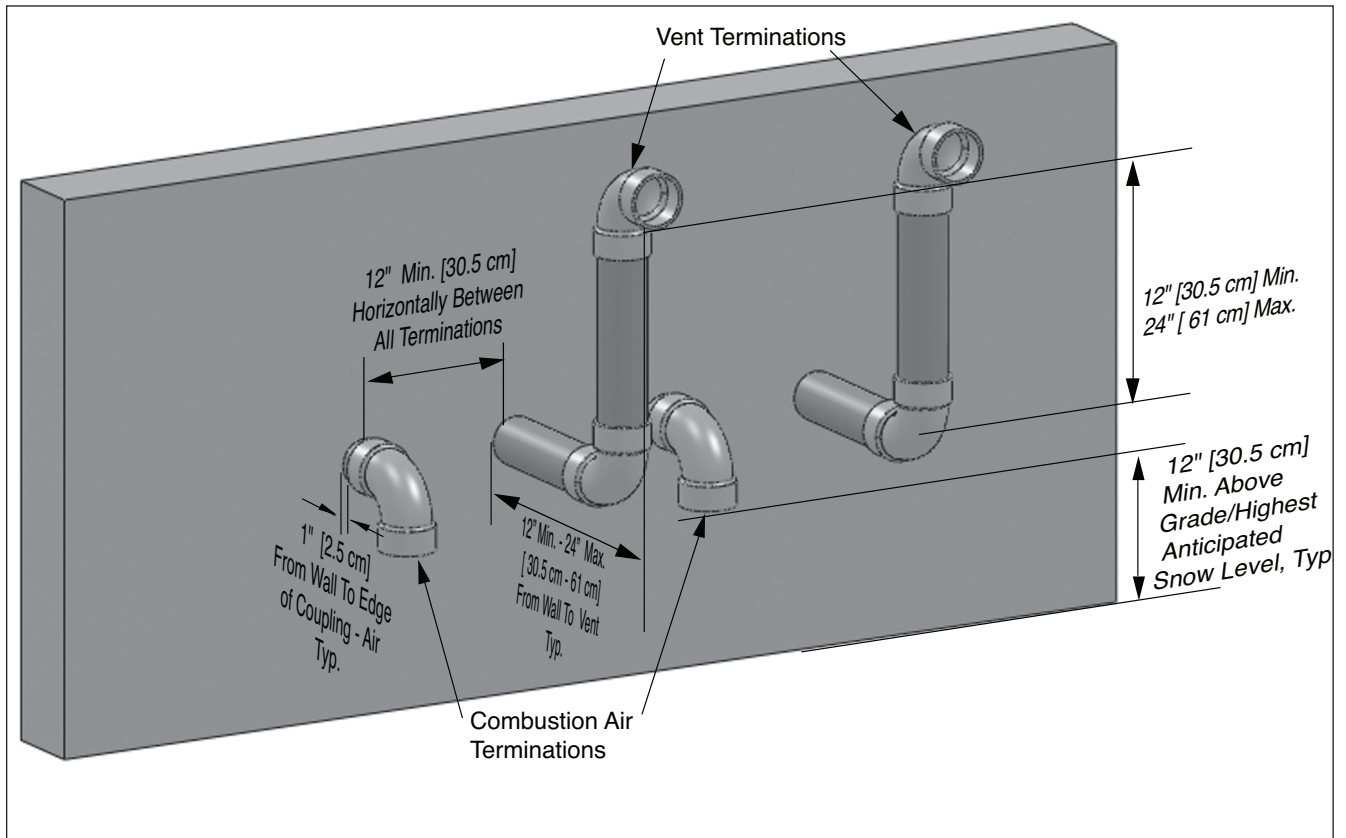

Fig. 11 - Direct Vent - Sidewall Termination of Multiple GALLANT Boilers

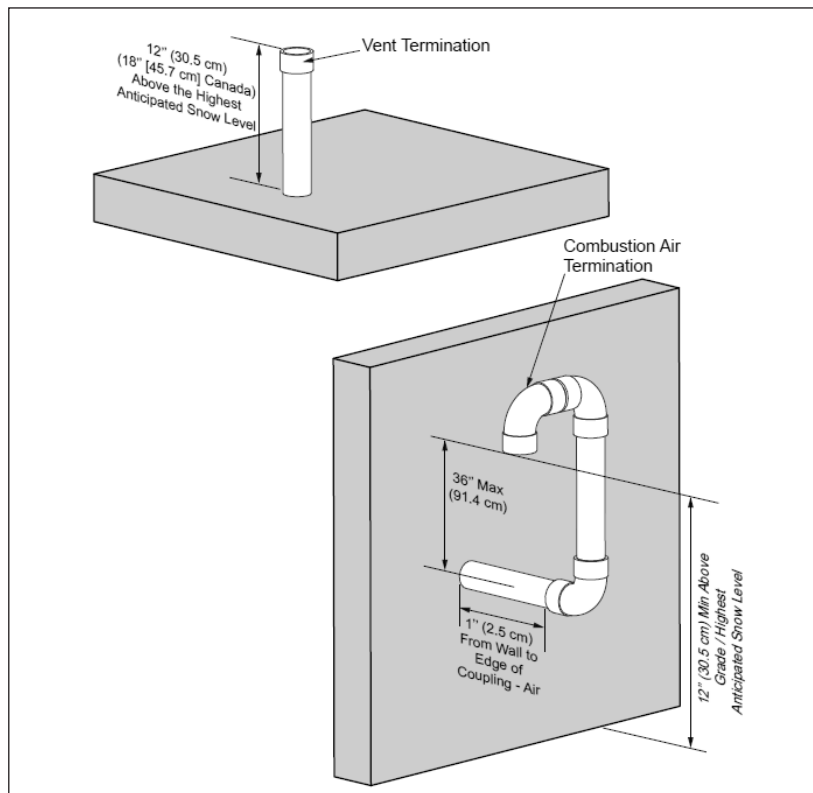

Fig. 12 - Direct Vent - Vertical Vent and Side Wall Combustion Air Terminations

## CHAPTER 2 - DIRECT VENT INSTALLATION OF VENT/AIR PIPING

### 2.3.4 Termination Fittings - Vertical & Sidewall

The combustion air termination in the horizontal orientation may lead to rainwater getting into the piping under specific weather conditions. Therefore, all combustion air termination should be built with a 90° elbow pointing down toward the ground.

All affected installations should be adjusted so that the combustion air piping terminates with 180° bend with the intake opening facing the ground using two 90° elbows. The termination must be located 12 in. [30.5 cm] (18 in. [46 cm] in Canada) above the highest anticipated snow level

1. The vent and combustion air terminations must include a factory supplied "bird screen" installed as shown in *Fig. 3 on page 14* & *Fig. 10 on page 18*.
2. The combustion air piping must terminate using a 90° elbow as shown in *Fig. 6 or Fig. 8 on page 17*.
3. The vent piping must terminate vertically with a coupling, as shown in *Fig. 12 on page 19*.



### WARNING

**Do not extend the vent pipe above the roof beyond the dimension shown in *Fig. 12 on page 19*. Extended exposure of the vent pipe could cause condensate to freeze and block the vent pipe, resulting in substantial property damage, serious injury, or death.**

### 2.3.5 Direct Vent - Multiple Boiler Installation - Vertical Vent and Sidewall Combustion Air

1. On installations of multiple GALLANT boilers, terminate each vent and combustion air pipe as described in this manual.
2. Each vent and combustion air termination must be a minimum 12 in. [30.5 cm] from the adjacent termination for installations in the U.S. as shown in *Fig. 13*. For installations in Canada, provide clearances as required by CAN/CSA B149.1.

### NOTICE

*The combustion air inlet of the GALLANT is defined as being part of a direct vent system. It is not considered as a forced air intake. The required clearance of an adjacent boiler vent to a forced air inlet does not apply in a multiple installation of GALLANT boilers.*

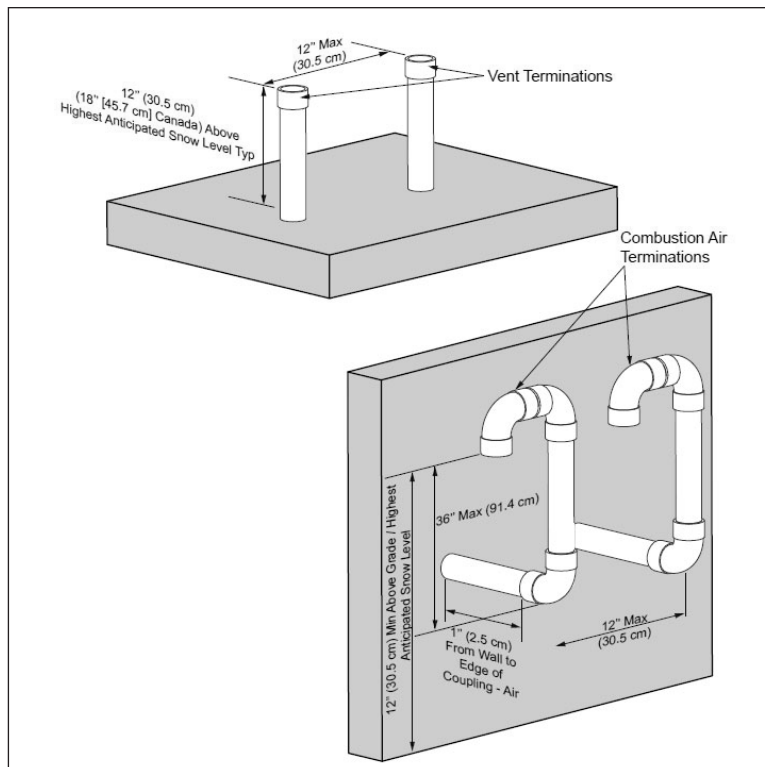

Fig. 13 - Direct Vent - Vertical Vent and Sidewall Combustion Air Terminations of Multiple GALLANT Boilers



## CHAPTER 3 - CATEGORY IV (INDOOR AIR) INSTALLATION OF VENT/AIR PIPING

A Category IV appliance utilizes uncontaminated indoor or outdoor air (surrounding the appliance) for combustion.

### 3.1. Category IV - Vertical - Through the Roof or Unused Chimney

#### NOTICE

- The installation must conform to the requirements of the authority having jurisdiction or, in the absence of such requirements, to the National Fuel Gas Code, ANSI Z223.1/NFPA 54, and/or Natural Gas and Propane Installation Code, CAN/CSA B149.1.
- When using an inoperative chimney as a means of a chase for the vent, the surrounding space within the chimney cannot be used to draw combustion air or vent another appliance.



**A gas vent extending through a roof must not terminate near an adjacent wall or below any building extensions such as roof eaves, balconies or decks. Failure to comply with the required clearances in this manual can result in substantial property damage, serious injury, or death.**

#### NOTICE

The information and diagrams outlining the fittings and method of terminating the vent/combustion air are directly related to PVC/CPVC vent systems. When utilizing an AL 29-4C® or Polypropylene vent system, there may be some variations. Consult the appropriate vent manufacturer for recommendations and clarifications.

### 3.1.1 Determine Termination Location

Locate the vent and combustion air termination using the following guidelines:

1. The total length of the vent piping must not exceed the limits given in *Table 5 on page 9*.
2. The combustion air piping must terminate at the boiler with a 90° elbow.
3. The vent piping must terminate vertically with a coupling to accept the bird screen and must be located 12 in. [30.5 cm] (18 in. [45.7 cm] Canada) above the highest anticipated snow level as shown in *Fig. 14 on page 21*
4. The following should be considered when determining the location of the vent termination:
  - a. Locate the vent termination where flue vapors will not damage surrounding shrubs, plants, air conditioning equipment or be objectionable to the homeowner.
  - b. The flue products will form a noticeable plume of water vapor as they condense in colder air. Avoid terminating the vent in areas where the plume could obstruct window views.
  - c. Prevailing winds could cause freezing of flue gas condensation and a buildup of water / ice on surrounding plants or building surfaces.
  - d. Avoid locations where prevailing winds could affect the performance of the boiler or cause recirculation of the flue gases, such as inside corners of buildings, near adjacent buildings, vertical surfaces, window wells, stairwells, alcoves, courtyards, or other recessed areas.

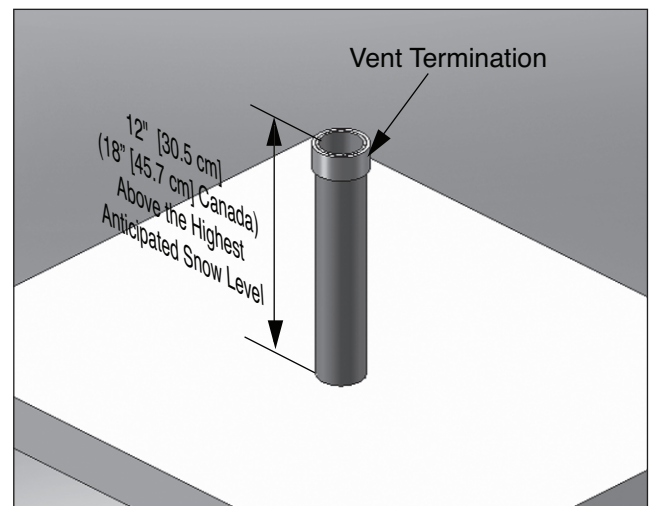

Fig. 14 - Category - IV - Vertical Termination of Vent Pipe

## CHAPTER 3 - CATEGORY IV (INDOOR AIR) INSTALLATION OF VENT/AIR PIPING

- e. Do not terminate the vent above doors or windows, flue condensate could freeze causing ice formations.
  - f. Locate the vent termination to prevent possible condensate damage to exterior finishes.
  - g. Avoid locations of possible accidental contact of flue vapors with people or pets.
5. The vent termination must also maintain the following clearances; as shown in *Fig. 15 below*.
- a. At least 3 ft. [0.9 m] from adjacent walls
  - b. At least 3 ft. [0.9 m] below roof overhangs
  - c. At least 7 ft. [2.1 m] above any public walkways
  - d. At least 3 ft. [0.9 m] above any forced air intake within 10 ft. [3 m] (Does not apply to the combustion air inlet of a direct vent appliance).
  - e. No closer than 4 ft. [1.2 m] below or horizontally from any door, window or gravity air inlet.
  - f. Must be at least 4 ft. [1.2 m] from any electric meters, gas meters-regulators, relief valves or other equipment. Never terminate the vent above or below any of these items within 4 ft. [1.2 m] horizontally.
  - g. A minimum 12 in. [30.5 cm] horizontal spacing from other fan assisted appliance vents. Never terminate the vent above or below any fan assisted vent within 12 in. [30.5 cm] horizontally.
6. Locate the vent termination in a manner to protect from damage by foreign objects, such as stones, balls, or buildup of leaves or sediment.
7. Do not connect any other appliance to the vent pipe or multiple boilers to a common vent pipe.

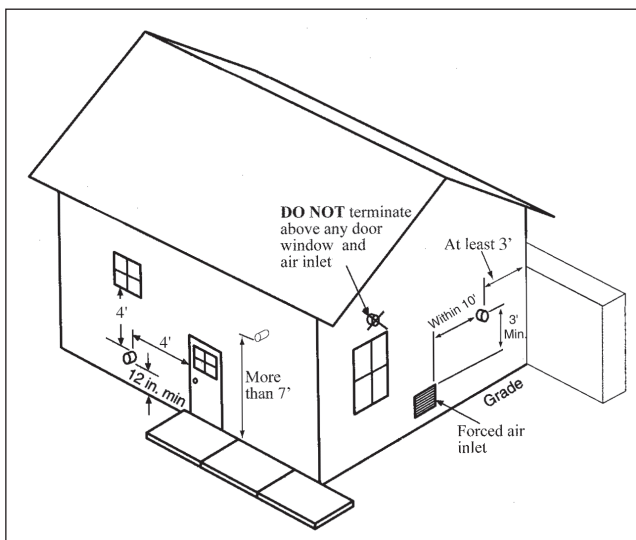

Fig. 15 - Termination Clearances of Category IV System

### 3.1.2 Category IV - Vent Installation - Through the Roof

1. Vent pipe penetration through combustible or non-combustible wall material must maintain a minimum 1/4 in. [6 mm] clearance for 3 in. [80 mm] and 4 in. [100 mm] PVC/CPVC vent. The diameter of the penetration hole must be 4 in. [10.2 cm] minimum for 3 in. [80 mm] pipe or 5 in. [12.7 cm] minimum for 4 in. [100 mm] pipe. When using Polypropylene or Stainless Steel Vent refer to vent manufacturer's Installation Instructions for clearances.
2. The installer must use a galvanized metal thimble for the vent pipe penetration.
3. Locate the vent pipe penetration to provide clearances as described in *Fig. 14 on page 21*.
4. The installer must comply with all local codes for isolating the vent pipe as it passes through floors, ceilings and roofs.
5. The installer must provide adequate flashing and a sealing boot sized for the vent pipe.

### 3.1.3 Termination Fittings - Through the Roof

1. The vent and combustion air terminations must include a factory supplied "bird screen" installed as shown in *Fig. 3* and *Fig. 4 on page 14*.
2. The combustion air piping must terminate at the boiler with a 90° elbow.
3. The vent piping must terminate vertically with a coupling as shown in *Fig. 14 on page 21*.



### WARNING

Do not extend the vent pipe above the roof beyond the dimensions shown in *Fig. 14 on page 21*. Extended exposure of the vent pipe could cause condensate to freeze and block the vent pipe, resulting in substantial property damage, serious injury, or death.

## CHAPTER 3 - CATEGORY IV (INDOOR AIR) INSTALLATION OF VENT/AIR PIPING

### 3.1.4 Category IV - Multiple Boiler Installation - Through the Roof

1. On installations of multiple GALLANT boilers, terminate each vent pipe as described in this manual.
2. Each vent termination must be a minimum 12 in. [30.5 cm] from the adjacent termination for installations in the U.S. as shown in *Fig. 16 below*. For installations in Canada, provide clearances as required by CAN/CSA B149.1.

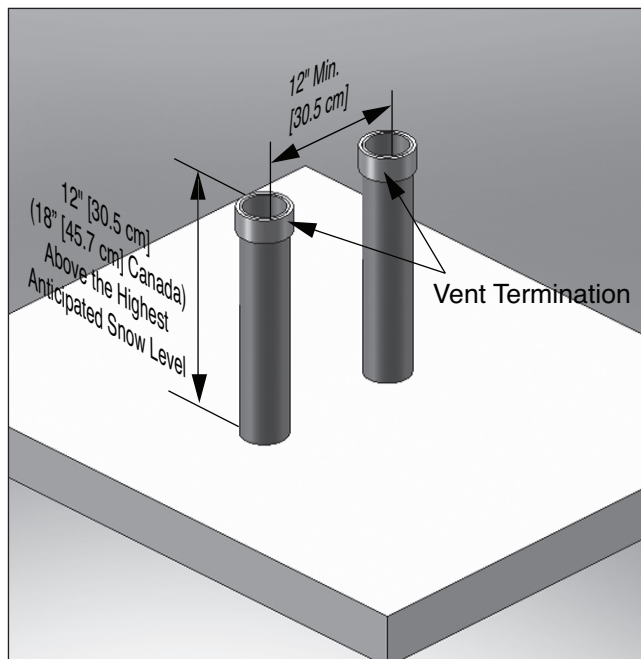

Fig. 16 - Category IV- Vertical Termination of Multiple GALLANT Boilers

### 3.2. Category IV - Horizontal - Sidewall

#### NOTICE

- *The installation must conform to the requirements of the authority having jurisdiction or, in the absence of such requirements, to the National Fuel Gas Code, ANSI Z223.1/NFPA 54, and/or Natural Gas and Propane Installation Code, CAN/CSA B149.1.*
- *For sidewall vented installations in the Commonwealth of Massachusetts, the installer must comply with the additional requirements outlined in Chapter 6 - Commonwealth of Massachusetts Installation Requirements on page 31.*



A gas vent extending through a sidewall must not terminate near an adjacent wall or below any building extensions such as roof eaves, balconies or decks. Failure to comply with the required clearances in this manual can result in substantial property damage, serious injury, or death.

#### NOTICE

*The information and diagrams outlining the fittings and method of terminating the vent/combustion air are directly related to PVC/CPVC vent systems. When utilizing an AL29-4C® or Polypropylene vent system, there may be some variations. Consult the appropriate vent manufacturer for recommendations and clarifications.*

#### 3.2.1 Determine Termination Location

Locate the vent and combustion air termination using the following guidelines:

1. The total length of the vent piping must not exceed the limits given in *Table 5 on page 9*.

#### NOTICE

*Do not include the 90° elbows used to terminate the vent exterior of the building when determining the total length of pipe.*

2. The combustion air piping must terminate at the boiler with a 90° elbow.

## CHAPTER 3 - CATEGORY IV (INDOOR AIR) INSTALLATION OF VENT/AIR PIPING

3. The vent piping can terminate:
  - Using a coupling as shown in *Fig. 17*.
  - Using a 90° elbow as shown in *Fig. 18*.
  - The vent termination must be located 12 in. [30.5 cm] minimum above grade / highest anticipated snow level.
4. The following should be considered when determining the location of the vent termination:
  - a. Locate the vent termination where flue vapors will not damage surrounding shrubs, plants, air conditioning equipment or be objectionable to the homeowner.
  - b. The flue products will form a noticeable plume of water vapor as they condense in colder air. Avoid terminating the vent in areas where the plume could obstruct window views.
  - c. Prevailing winds could cause freezing of flue gas condensation and a buildup of water / ice on surrounding plants or building surfaces.
  - d. Avoid locations where prevailing winds could affect the performance of the boiler or cause recirculation of the flue gases, such as inside corners of buildings, near adjacent buildings, vertical surfaces, window wells, stairwells, alcoves, courtyards, or other recessed areas.
  - e. Do not terminate the vent above doors or windows, flue condensate could freeze causing ice formations.
  - f. Locate the vent termination to prevent possible condensate damage to exterior finishes.
  - g. Avoid locations of possible accidental contact of flue vapors with persons or pets.
5. The vent termination must also maintain the following clearances; as shown in *Fig. 15 on page 22*.
  - a. At least 3 ft. [0.9 m] from adjacent walls
  - b. At least 3 ft. [0.9 m] below roof overhangs
  - c. At least 7 ft. [2.1 m] above any public walkways
  - d. At least 3 ft. [0.9 m] above any forced air intake within 10 ft. [3 m] (Does not apply to the combustion air inlet of a direct vent appliance).
  - e. No closer than 4 ft. [1.2 m] below or horizontally from any door, window or gravity air inlet.
  - f. Must be at least 4 ft. [1.2 m] from any electric meters, gas meters-regulators, relief valves or other equipment. Never terminate the vent above or below any of these items within 4 ft. [1.2 m] horizontally.
6. Locate the vent termination in a manner to protect from damage by foreign objects, such as stones, balls, or buildup of leaves or sediment.
7. Do not connect any other appliance to the vent pipe or multiple boilers to a common vent pipe.

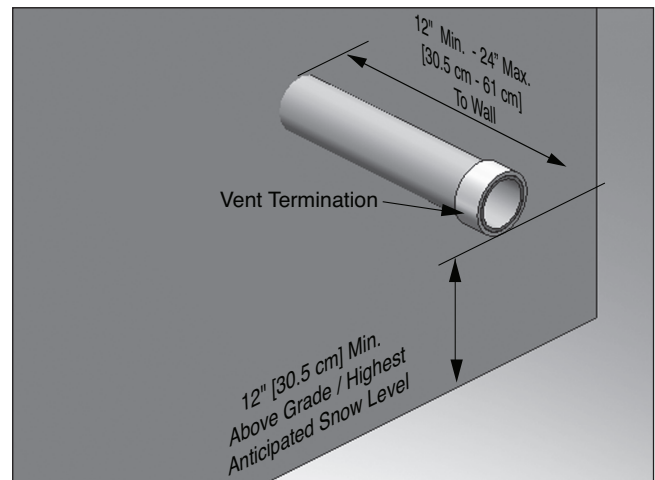

*Fig. 17 - Category IV - Sidewall Termination of Vent Pipe*

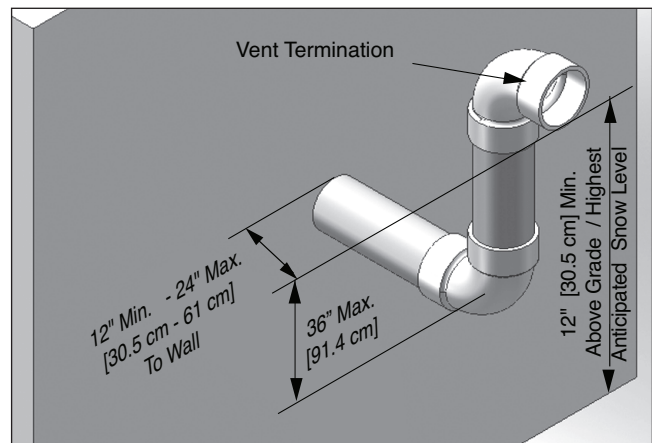

*Fig. 18 - Category IV - Sidewall Snorkel Termination of Vent Pipe*

## CHAPTER 3 - CATEGORY IV (INDOOR AIR) INSTALLATION OF VENT/AIR PIPING

### 3.2.2 Category IV - Vent Installation - Sidewall

1. Vent pipe penetration through combustible or non-combustible wall material must maintain a minimum 1/4 in. [6 mm] clearance for 3 in. [80 mm] and 4 in. [100 mm] PVC/CPVC vent. The diameter of the penetration hole must be 4 in. [10.2 cm] minimum for 3 in. [80 mm] pipe or 5 in. [12.7 cm] minimum for 4 in. [100 mm] pipe. When using Polypropylene or Stainless Steel Vent, refer to the vent manufacturer's Installation Instructions for clearances.
2. The installer must use a galvanized metal thimble for the vent pipe penetration.
3. Locate the vent pipe penetration to provide clearances as described in *Fig. 17* and *Fig. 18* on page 24.
4. The installer must comply with all local codes for isolating the vent pipe as it passes through floors and walls.
5. The installer must seal all exterior openings around penetration with an exterior silicon caulk.

### 3.2.3 Termination Fittings - Sidewall

1. The vent and combustion air terminations must include a factory supplied "bird screen" installed as shown in *Fig. 9* & *Fig. 10* on page 18.
2. The combustion air piping must terminate at the boiler with a 90° elbow.
3. The vent piping can terminate:
  - Using a coupling as shown in *Fig. 17* on page 24.
  - Using a 90° elbow as shown in *Fig. 18* on page 24.



**Do not extend the vent pipe outside the sidewall beyond the dimensions shown in *Fig. 17* and *Fig. 18* on page 24. Extended exposure of the vent pipe could cause condensate to freeze and block the vent pipe, resulting in substantial property damage, serious injury, or death.**

### 3.2.4 Category IV - Multiple Boiler Installation - Sidewall

1. On installations of multiple GALLANT boilers, terminate each vent pipe as described in this manual.
2. Each vent termination must be a minimum 12 in. [30.5 cm] from the adjacent termination for installations in the U.S. as shown in *Fig. 19* below. For installations in Canada, provide clearances as required by CAN/CSA B149.1.

#### NOTICE

- *Fig. 19* shows one option for vent terminations of multiple GALLANT boilers. Either termination option shown in *Fig. 17* or *Fig. 18* on page 24 can be used for multiple GALLANT boilers. The 12 in. [30.5 cm] minimum distance between centerlines of the vent piping must be maintained for any chosen option.
- Reference *Fig. 17* and *Fig. 18* on page 24 for vent termination dimensions for each unit installed in a multiple installation.

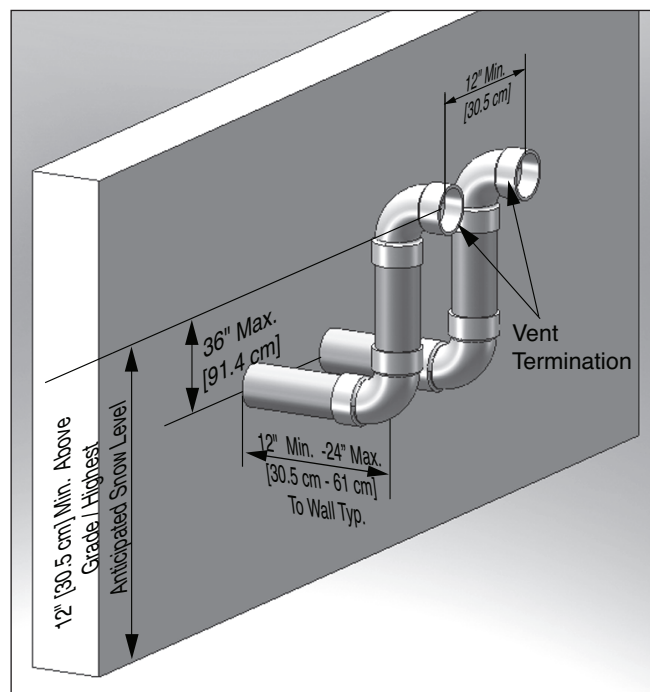

*Fig. 19 - Category IV - Sidewall Termination of Multiple GALLANT Boilers*



## CHAPTER 4 - INSTALLATION REQUIREMENTS

### 4.1. Vent/Combustion Air Transitions

#### 4.1.1 3 in. [80 mm] to 4 in. [100 mm] Transitions

#### NOTICE

*This Chapter outlines the installation of 4 in. [100 mm] Venting and Combustion Air piping for all GALLANT models when the vent system must transition from the 3 in. [80 mm] outlet of the boiler to the 4 in. [100 mm] vent system.*

1. The transition from 3 in. [80 mm] vent system to 4 in. [100 mm] vent system must occur within 5 ft. [1.5 m] of the boiler vent outlet.
2. The transition from 3 in. [80 mm] vent to 4 in. [100 mm] vent must occur in a vertical run only.



#### WARNING

**Transition of 3 in. [80 mm] vent to 4 in. [100 mm] vent in a horizontal run will result in pooling of the condensate and potential vent blockage. Failure to transition from 3 in. [80 mm] vent to 4 in. [100 mm] vent in a vertical run can result in substantial property damage, serious injury, or death.**

3. Use a 4 in.x3 in. bell reducer to make the transition to 4 in. [100 mm] CPVC/PVC vent. See *Fig. 20 & Fig. 21*.
4. Use a 3 in. [80 mm] appliance vent adapter and 4 in. [100 mm] to 3 in. [80 mm] reducer to make the transition to 4 in. [100 mm] Polypropylene vent. See *Table 3 on page 5*.
5. The 4 in. [100 mm] vent must not transition back to 3 in. [80 mm] vent at any point in the vent system except when using Ideal's optional PVC concentric vent termination kit. See kit instructions for details.
6. The PVC combustion air piping shall transition from 3 in. [80 mm] to 4 in. [100 mm] using a 4 in.x3 in. bell reducer and shall transition in a similar manner as the vent system.
7. The total equivalent length of the 3 in. [80 mm] vent and 4 in. [100 mm] vent piping combined shall not exceed the length listed for a 4 in. [100 mm] vent system in *Table 5 on page 9*
8. The total equivalent length of 3 in. [80 mm] and 4 in. [100 mm] combustion air piping combined shall not exceed the length listed for a 4 in. [100 mm] combustion air system in *Table 5 on page 9*.

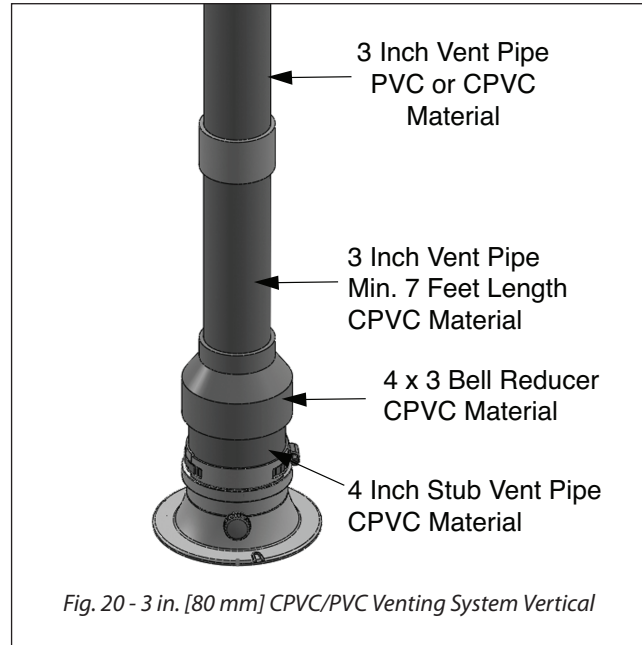

Fig. 20 - 3 in. [80 mm] CPVC/PVC Venting System Vertical

### 4.2. Connect Piping to GALLANT

1. The installer must clean, deburr and chamfer the pipe ends prior to assembly.



#### WARNING

**The pipe ends must be smooth, free of sharp edges, chamfered and wiped clean to prevent possible damage to the sealing gasket in the vent and combustion air adapters. Failure to comply with this requirement can cause flue gas leakage, resulting in substantial property damage, serious injury, or death.**

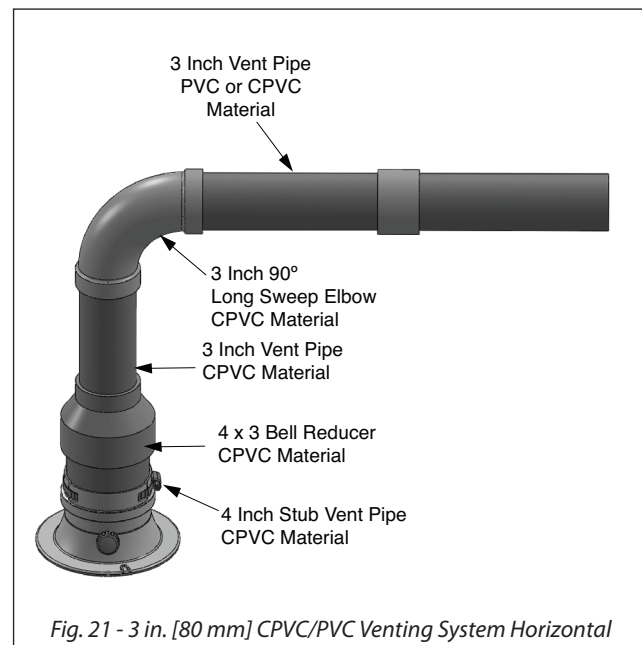

Fig. 21 - 3 in. [80 mm] CPVC/PVC Venting System Horizontal



## CHAPTER 4 - INSTALLATION REQUIREMENTS

2. Prior to inserting the pipe into the adapter:
  - Verify the vent and combustion air adapters are securely attached to the top of the jacket by turning clockwise.
  - Verify there is no packing material or obstructions inside the adapters and the gaskets are in place.
3. Ensure the adapter retaining strap is loose prior to inserting the pipe.
4. Apply a small amount of water to the insertion end of the pipe to ease insertion into the adapter.
5. Insert the pipe into the adapter until it is fully seated.



**Do not bend, twist or apply excessive force to the vent or combustion air adapters when installing the vent / combustion air piping. The adapter gasket could be damaged and leak flue gas, resulting in substantial property damage, serious injury, or death.**

6. Secure the vent and combustion air pipes by tightening the adapter retaining strap. Do not over tighten the strap. The seal is made by the gasket inside the adapter.

### 4.3. Vent and Combustion Air Piping Installation

#### 4.3.1 PVC/CPVC Vent System

1. The installer should install the vent / combustion air piping working from the boiler to the piping termination. The piping length must not exceed the lengths listed in *Table 5 on page 9*.
2. The installer should cut the pipe to the required length and must deburr the inside and outside of both ends.
3. The installer must chamfer the outside of the pipe ends to allow even distribution of cement when joining.
4. The installer must dry assemble the vent system prior to final assembly to ensure proper fit.
5. The pipe ends and fittings must be cleaned and dried thoroughly prior to final assembly.
6. When assembling a joint the installer must:
  - a. Handle fittings and pipes carefully to prevent contamination of surfaces
  - b. Apply a liberal amount of primer to both the end of the pipe and the insert socket of the fitting.

- c. Apply a light uniform coating of approved cement to both the end of the pipe and the insert socket of the fitting, while the primer is still wet.
  - d. A second coat of approved cement should be applied to the mating surfaces. The installer should avoid, however, using too much cement on the socket of the fitting to prevent a buildup of cement on the inside.
  - e. With the cement still wet, the pipe end should be inserted into the socket of the fitting and twisted 1/4 of a full turn. Ensure the pipe end is inserted fully into the socket of the fitting.
  - f. Any excess cement should be wiped clean from the joint. Inspect the joint to ensure a smooth bead of cement is around the entire joint seam.
7. The installer must use perforated metal strap hangers or equivalent pipe hangers suitable for plastic pipe to support the piping. The hangers must be placed at a maximum of every 5 ft. [1.5 m] of horizontal and vertical run of piping. A support must be placed at the boiler and at every vertical or horizontal change in direction (i.e. elbow). Do not penetrate any part of the piping or vent system with a fastener.



**Failure to properly support vent system can cause the venting system to fail, resulting in substantial property damage, serious injury, or death.**

### NOTICE

*Pipe hangers must not be tightly clamped to pipe to allow for thermal expansion/contraction movement. Pipe clamps or hangers should not contain any sharp edges which can damage the pipe.*

8. The vent and combustion air piping must be sloped continuously from the termination back to the boiler with at least 1/4 in. drop per ft. [6 mm/30 cm] of run. Do not allow any sags in the run of piping.



**Do not slope the vent or combustion air piping downward away from the boiler. Condensate could freeze and block the vent pipe or damage the exterior of the building or surrounding landscape, resulting in substantial property damage, serious injury, or death.**

## CHAPTER 4 - INSTALLATION REQUIREMENTS

9. Maintain a minimum clearance of 1/4 in. [6 mm] between the vent pipe and all combustible or non-combustible materials for 3 in. [80 mm] and 4 in. [100 mm] PVC/CPVC vents. The installer must seal any wall, floor or ceiling penetrations as per local code requirements.

### BEST PRACTICE

*It is recommended that the installer uses the same number of elbows and length of pipes on the venting and the combustion air inlet systems.*

### NOTICE

*Covering PVC/CPVC or Polypropylene vent pipe and fittings with thermal insulation is prohibited.*

#### 4.3.2 Polypropylene or Stainless Steel Vent Systems

### NOTICE

- *When using Polypropylene or Stainless Steel Vent, refer to vent manufacturer's installation instructions supplied with the vent for proper installation.*
- *Covering Polypropylene vent pipe and fittings with thermal insulation is prohibited.*

#### 4.4. Carbon Monoxide Detector Installation



**The installer must verify that at least one carbon monoxide alarm has been installed within a residential living space or home following the alarm manufacturer's instructions and applicable local codes before putting the appliance into operation.**

Ideal Heating North America follows the recommended advice of CPSC and requires the installation of a minimum of two (2) carbon monoxide detectors with an alarm and battery back-up if hard wired; one in the mechanical room where the GALLANT is located and another installed in the area outside each sleeping area for all installations.

Each carbon monoxide detector shall comply with NFPA 720 and be ANSI/UL 2034 listed and IAS certified.

Consult the local authority having jurisdiction for any additional carbon monoxide detector requirements in your area. See *Chapter 6 on page 31* for additional carbon monoxide detector requirements in Massachusetts.



**A byproduct of any gas fired appliance is carbon monoxide. Failure to install carbon monoxide detectors with alarms can result in serious injury, or death.**

### 5.1. Manifold Combustion Air Option for Multiple GALLANT Boilers

1. Common combustion air manifold is restricted to horizontal/side wall terminations only.
2. The number of GALLANT boilers connected to a common combustion air manifold system is limited by the combined maximum boiler input shown in *Table 6 below*.
3. The combustion air manifold must be constructed of round solid core PVC pipe with minimum diameter based on combined maximum boiler input. See *Table 6 below*.

Combined Maximum Input (MBH)	Minimum Diameter of Combustion Air Piping
<400	4 in. [100 mm]
400-600	5 in. [125 mm]
601-800	6 in. [150 mm]
801-1600	8 in. [200 mm]
1601 -2000	10 in. [250 mm]

*Table 1 - Common Combustion Air Piping*

### 5.2. Combustion Air Manifold Equivalent Length

1. The maximum equivalent length of the combustion air manifold must not exceed the lowest maximum allowable length for the boilers connected to the manifold per *Table 5 on page 9*.
2. Reduce the maximum equivalent length of the combustion air manifold as follows:
  - 5 ft. [1.5 m] for every 45° elbow
  - 10 ft. [3.0 m] for every 90° elbow

### 5.3. Sidewall Termination

- The common combustion air manifold must terminate horizontally on a side wall using a 90° elbow pointed downward.
- The inlet elbow of the common combustion air termination must include a corrosion resistant field supplied bird screen.
- The edge of the common combustion air termination coupling must extend 1 in. (2.5 cm) beyond the exterior wall as shown in *Fig. 6 on page 17*.
- The inlet of the common combustion air termination must be located 12 in. (30.5 cm) minimum above grade/highest anticipated snow level.
- The common combustion air termination must be a minimum of 3 ft. (0.9 m) below any appliance vent termination within 10 ft. (3 m) horizontally.
- The common combustion air termination must be a minimum of 3 ft. (0.9 m) horizontally from any appliance vent termination.
- Avoid locating the common combustion air termination in a location where prevailing winds could affect the performance of the boilers or cause recirculation of flue gases, such as inside corners of buildings, near adjacent buildings, vertical surfaces, window wells, stairwells, alcoves, courtyards, or other recessed areas. The common combustion air termination must be installed a minimum of 6 ft. horizontally from any such locations.
- Locate the common combustion air termination in a manner to protect from damage by foreign objects, such as stones, balls, or buildup of leaves or sediment.

### 5.4. Installation Guidelines

- Use perforated metal strap hangers or equivalent pipe hangers suitable for plastic pipe to support the common combustion air manifold. Hangers must be placed at a maximum of every 5 ft [1.5 m] of horizontal and vertical run of piping. A support must be placed at every boiler and at every vertical or horizontal change in direction. Do not penetrate any part of the piping with a fastener.

### 5.5. Transition Boiler Air Piping to Manifold Guidelines

- The transition piping from the boiler adapter to the common combustion air manifold must be 3 in. for the GALLANT 250 model, and 4 in. for the GALLANT 299 & 399.
- Reference *Section 1.3 on page 2* for reductions in maximum allowable length.

#### **BEST PRACTICE**

*To maintain the maximum allowable length of the combustion air manifold, keep the boiler transition piping to a minimum using the minimum amount of fittings and pipe.*

## CHAPTER 6 - COMMONWEALTH OF MASSACHUSETTS INSTALLATION REQUIREMENTS

For all side wall horizontally vented gas fueled equipment installed in every dwelling, building or structure used in whole or in part for residential purposes, including those owned or operated by the Commonwealth and where the side wall exhaust vent termination is less than seven (7) ft. [2.1 m] above finished grade in the area of the venting, including but not limited to decks and porches, the following requirements shall be satisfied:

### 6.1. Installation of Carbon Monoxide Detectors.



**The installer must verify that at least one carbon monoxide alarm has been installed within a residential living space or home following the alarm manufacturer's instructions and applicable local codes before putting the appliance into operation.**

1. At the time of installation of the side wall horizontal vented gas fueled equipment, the installing plumber or gasfitter shall observe that a hard wired carbon monoxide detector with an alarm and battery back-up is installed on the floor level where the gas equipment is to be installed.
2. In addition, the installing plumber or gasfitter shall observe that a battery operated or hard wired carbon monoxide detector with an alarm is installed on each additional level of the dwelling, building or structure served by the side wall horizontal vented gas fueled equipment.
3. It shall be the responsibility of the property owner to secure the services of qualified licensed professionals for the installation of hard wired carbon monoxide detectors.
  - a. In the event that the side wall horizontally vented gas fueled equipment is installed in a crawl space or an attic, the hard wired carbon monoxide detector with alarm and battery back-up may be installed on the next adjacent floor level.
  - b. In the event that the requirements of this subdivision can not be met at the time of completion of installation, the owner shall have a period of thirty (30) days to comply with the above requirements; provided, however, that during said thirty (30) day period, a battery operated carbon monoxide detector with an alarm shall be installed.

### 6.2. Approved Carbon Monoxide Detectors.

Each carbon monoxide detector as required in accordance with the above provisions shall comply with NFPA 720 and be ANSI/UL 2034 listed and IAS certified.

### 6.3. Signage

A metal or plastic identification plate shall be permanently mounted to the exterior of the building at a minimum height of eight (8) ft. [2.4 m] above grade directly in line with the exhaust vent terminal for the horizontally vented gas fueled heating appliance or equipment.

The sign shall read, in print size no less than one half (1/2) in. [12.5 mm] in size, "**GAS VENT DIRECTLY BELOW. KEEP CLEAR OF ALL OBSTRUCTIONS**".

## **CHAPTER 6 - COMMONWEALTH OF MASSACHUSETTS INSTALLATION REQUIREMENTS**

### **6.4. Inspection.**

The state or local gas inspector of the side wall horizontally vented gas fueled equipment shall not approve the installation unless, upon inspection, the inspector observes carbon monoxide detectors and signage installed in accordance with the provisions of 248 CMR 5.08(2)(a) 1 through 4.

#### **6.4.1 Exemptions**

The following equipment is exempt from 248 CMR 5.08(2)(a) 1 through 4:

1. The equipment listed in Chapter 10 entitled "Equipment Not Required To Be Vented" in the most current edition of NFPA 54 as adopted by the Board; and
2. Product Approved side wall horizontally vented gas fueled equipment installed in a room or structure separate from the dwelling, building or structure used in whole or in part for residential purposes.

#### **6.4.2 Manufacturer Requirements - Gas Equipment Venting System Provided.**

When the manufacturer of Product Approved side wall horizontally vented gas equipment provides a venting system design or venting system components with the equipment, the instructions provided by the manufacturer for installation of the equipment and the venting system shall include:

1. Detailed instructions for the installation of the venting system design or the venting system components; and
2. A complete parts list for the venting system design or venting system.

#### **6.4.3 Manufacturer Requirements - Gas Equipment Venting System Not Provided.**

When the manufacturer of a Product Approved side wall horizontally vented gas fueled equipment does not provide the parts for venting the flue gases, but identifies "special venting systems", the following requirements shall be satisfied by the manufacturer:

1. The referenced "special venting system" instructions shall be included with the appliance or equipment installation instructions; and
2. The "special venting systems" shall be Product Approved by the Board, and the instructions for that system shall include a parts list and detailed installation instructions.

A copy of all installation instructions for all Product Approved side wall horizontally vented gas fueled equipment, all venting instructions, all parts lists for venting instructions, and/or all venting design instructions shall remain with the appliance or equipment at the completion of the installation.



A series of horizontal dotted lines spanning the width of the page, providing a guide for handwriting practice.



## Additional quality water heating equipment available from Ideal Heating North America

### Monarch Indirect Water Heater



- Sizes: 30, 40, 50, 60, 80, 100, 120 Gallons
- All Stainless Steel Construction
- Corrugated Coil
- Top Connections  
DHW & Recirc.: 3/4 in. (30 to 60) & 1 in. (80-120)
- 1 in. Boiler Connections
- Factory Included: T&P Valve, 1/2 in. Drain Valve, Aquastat
- AHRI Certified Rating and Listed
- Ideal Heating North America Advantage Warranty Program