PRESTIGE Solo 399

Service Parts Instructions



Kit Part Number: PSRKIT92

Recommended tools:

- A. Pipe wrenches
- B. Phillips and flat head screwdrivers
- C. 10 mm socket and/or 10 mm wrench
- D. Adjustable wrench
- E. Needle nose pliers
- F. Calibrated combustion analyzer
- G. T20 Torx screwdriver

Kit Includes:

- Qty 1 - 399 INSULATION/GASKET
- Qty 1 - SIGHT GLASS ASSEMBLY
- Qty 1 - PS399 IGNITER
- Qty 1 - PT399 IGNITER
- Qty 1 - GASKET: HX/FLUE PIPE
- Qty 1 - GASKET: VENT ADAPTER
- Qty 1 - GASKET: BURNER HEAD
- Qty 2 - GASKET: IGNITER
- Qty 4 - GASKET: PIPING
- Qty 1 - WASHER: CONDENSATE TRAP
- Qty 1 - WIRE TIE
- Qty 1 - CONNECTOR: IGNITER GROUND WIRE
- Qty 1 - AIR VENT
- Qty 4 - IGNITER SCREW



Indicates a potentially hazardous situation which, if ignored, can result in serious injury or substantial property damage.



For your safety, turn off electrical power supply at service panel and allow unit to cool before proceeding to avoid possible electrical shock and scald hazard. Failure to do so can cause severe personal injury or death.



Use a two wrench method when tightening piping onto the boiler piping connections. Use one wrench to prevent the boiler piping from turning / twisting. Failure to support the boiler piping and connections in this manner could cause damage to the boiler and its components.



Failure to follow instructions below can result in severe personal injury or damage if ignored.

- **Instructions are for a qualified installer/service technician only.**
- **Read all instructions before proceeding.**
- **Follow instructions in proper order.**

PRESTIGE Solo 399

Service Parts Instructions

Maintenance Procedures



Every PRESTIGE Boiler should be inspected and serviced annually, preferably at the start of the heating season, by a qualified service technician. Failure to service and maintain the PRESTIGE Boiler and the system components could result in equipment failure, causing possible severe personal injury, death or substantial property damage.

Reported Problems

Any problems reported by the owner should be checked, verified and corrected before proceeding with any maintenance procedures.

Check Surrounding Area

1. Verify that the area surrounding the PRESTIGE is free of combustible / flammable materials or flammable vapors or liquids. Remove immediately if found.
2. Verify that combustion air inlet area is free of any contaminants. If any of these products are in the area from which the unit takes its combustion air, they must be removed immediately or the combustion air intake must be relocated to another area.

Potential contaminating products

- Spray cans containing chloro/fluorocarbons
- Permanent Wave Solutions
- Chlorinated wax
- Chlorine - based swimming pool chemicals / cleaners
- Calcium Chloride used for thawing ice
- Sodium Chloride used for water softening
- Refrigerant leaks

- Paint or varnish removers
- Hydrochloric acid / muriatic acid
- Cements and glues
- Antistatic fabric softeners used in clothes dryers
- Chlorine-type bleaches, detergents, and cleaning solvents found in household laundry rooms
- Adhesives used to fasten building products and other similar products

Areas likely to contain these products

- Dry cleaning / laundry areas and establishments
- Beauty salons
- Metal fabrication shops
- Swimming pools and health spas
- Refrigeration Repair shops
- Photo processing plants
- Auto body shops
- Plastic manufacturing plants
- Furniture refinishing areas and establishments
- New building construction
- Remodeling areas
- Garages with workshops

Inspect Burner Area

1. Remove the boiler front jacket panel and venturi inlet elbow.
2. Vacuum any dirt or debris from the burner/blower components.
3. Check the burner plate mounting nuts for tightness.
4. Check burner plate gasket for discoloration or damage. Replace gasket if necessary.
5. Re-install venturi inlet elbow. Replace the venturi inlet elbow o-ring gaskets on the venturi if the

PRESTIGE Solo 399

Service Parts Instructions

venturi inlet elbow is not firmly attached to the venturi.



Do not use solvents to clean any of the burner components. The components could be damaged, resulting in unreliable or unsafe operation.

Check System Piping

1. Inspect all piping (water and gas) on the boiler system for leaks and verify that the piping is leak free and properly supported.
2. Inspect the fittings and components on the unit and verify they are leak free.



Eliminate all boiler water system leaks. Continual fresh make-up water will reduce the heat exchanger life causing boiler failure. Leaking water may also cause severe property damage to the surrounding area. Inspect the gas supply piping for any leaks.

Clean Condensate Drain Assembly

1. Loosen the retaining nut from the condensate drain assembly and disconnect the assembly from the boiler.



Ensure the installation of the condensate drain assembly included the metal washer when attaching to a polypropylene condensate pan. Failure to comply could result in the trap assembly dislocating from the boiler.

2. A new metal washer must be installed if the installation of the condensate drain assembly did not include a metal washer when attaching to a polypropylene condensate pan. Insert the

metal washer into the retaining nut and screw onto the condensate drain assembly without rubber gaskets. Use the condensate drain assembly as a tool to press the retaining nut with metal washer onto the polypropylene condensate pan. Unscrew the condensate drain assembly and proceed to the next step.

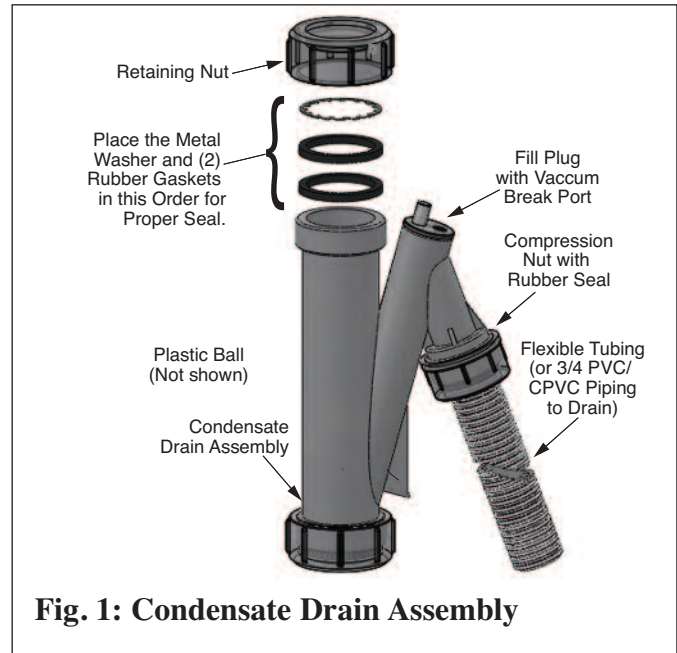

Fig. 1: Condensate Drain Assembly

3. Empty any water from the condensate drain assembly. Flush with fresh water as necessary to clean.
4. Check the drain piping from the condensate drain assembly to the drain. Flush to clean as necessary.
5. Reassemble the condensate drain assembly onto the boiler by tightening the retaining nut with rubber seal onto the boiler.
6. Remove the fill plug on the condensate drain assembly and fill with water.
7. Replace the fill plug on drain assembly.

PRESTIGE Solo 399

Service Parts Instructions

Check Ventilation Air Openings

1. Verify that all ventilation openings to the mechanical room or building are open and unobstructed. Check the operation and wiring of any automatic ventilation dampers.
2. Check and verify the vent discharge and the combustion air intake are free of debris and obstructions.

Inspect Vent and Combustion Air Piping

1. Visually inspect the venting system and combustion air piping for blockage, deterioration or leakage. Repair any deficiencies.
2. Verify that the combustion air inlet piping is connected, sealed and properly supported.
3. Inspect the vent outlet adaptor gasket at the top of boiler cabinet and look for signs of flue gas leakage. Replace gasket if necessary, see Fig. 2.
4. Inspect stainless steel test port (Fig. 2) for any signs of deterioration, if present replace entire vent outlet adaptor immediately.

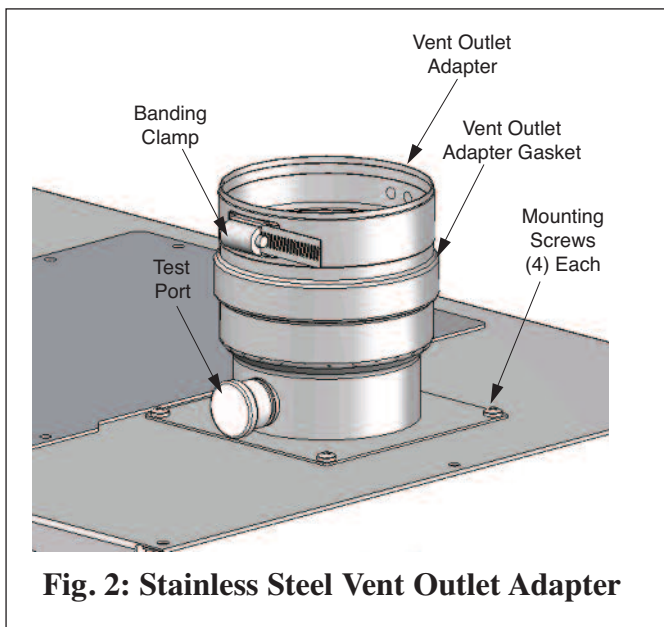

Fig. 2: Stainless Steel Vent Outlet Adapter

5. Inspect vent/heat exchanger gasket and look for signs of flue gas leakage. Replace gasket if necessary, see Fig. 3.

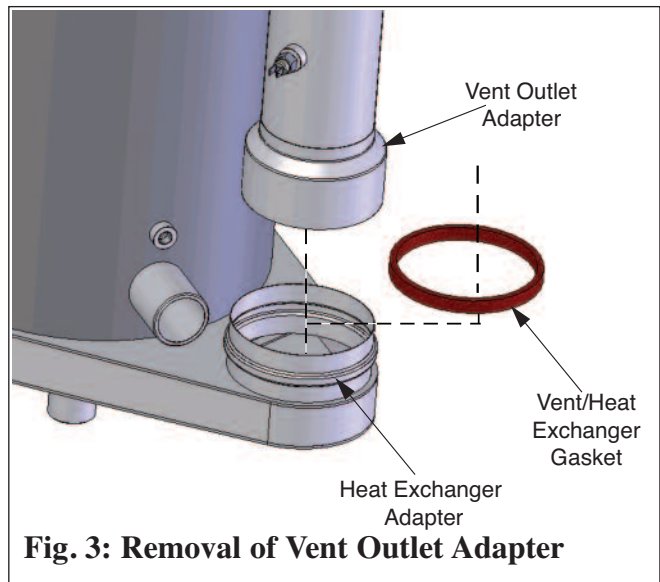

Fig. 3: Removal of Vent Outlet Adapter



Failure to inspect the vent system and combustion air inlet piping and to have any conditions repaired, can result in severe personal injury or death.

Check Boiler System

1. Verify all system components are correctly installed and operating properly.
2. Check the cold fill pressure for the system, typical cold water fill pressure is 12 psig.
3. Verify the system pressure, as the unit operates at high temperature, to ensure the pressure does not exceed 25 psig. Excessive pressure reading indicates expansion tank sizing is incorrect or system performance problems.
4. Inspect air vents and air separators in the system. Remove the caps on automatic air vents and briefly depress the valve stem to flush vent. Replace the cap when completed. Ensure vents do not leak, replace any leaking air vents. Tighten cap on new air vent equipped with hygroscopic cap.

PRESTIGE Solo 399

Service Parts Instructions

Check Expansion Tank

Closed -Type Tank:

1. Ensure tank is partially filled with water leaving an air gap as a cushion. Refer to the manufacturer's instruction for proper fill level.
2. Ensure the tank is fitted with a device that reduces gravity circulation of air-saturated tank water back into the system. This device prevents air from bubbling up through the water as it returns from the system.
3. Ensure no automatic air vents are used in the system. This will allow air to escape from the system instead of returning to the tank.

Diaphragm Tank:

1. Ensure the system contains a minimum of one automatic air vent. Recommended location of the air vent should be atop an air eliminator.
2. Remove the tank from the system and check the charge pressure. For residential applications the charge pressure is typically 12 psig. If tank does not hold a charge pressure, then the membrane is damaged and the tank should be replaced.

Check Boiler Relief Valve

1. Inspect the relief valve and lift the lever to verify flow at least annually or as recommended on the warning tag of the valve.



Before manually operating the pressure relief valve, ensure the discharge piping is directed to a suitable place of disposal to avoid a potential scald hazard. The discharge piping must be full size without restriction and installed to permit complete drainage of both the valve and line.

2. If after closing the valve, the valve fails to seat properly or continually weeps, replace the relief valve. Ensure the cause of the relief valve to weep is the valve itself, not due to system over-pressurization caused by an expansion tank that is waterlogged or undersized.

Inspection of Sight Glass

1. Visually inspect sight glass and gasket for signs of deterioration.
2. Replace sight glass if necessary.

Inspection of Igniter

1. Remove the igniter from the burner mounting plate.
2. Verify igniter gap is within specifications shown below.

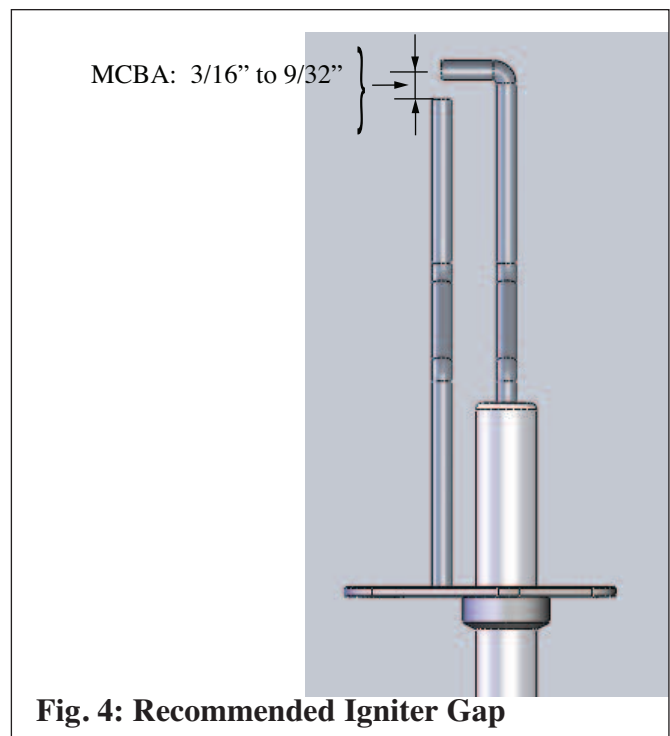

3. Remove any white oxides accumulated on the electrode using fine grit sandpaper or steel wool. If the electrode does not clean to a satisfactory condition, replace the igniter.
4. When replacing the igniter, ensure the gasket is in good condition and correctly positioned. Replace gasket if necessary.
5. Tighten igniter screws evenly. See Table 1, page 14 for torque specifications.

PRESTIGE Solo 399

Service Parts Instructions

Check Ignition Cable and Ground Wire

1. Inspect the ignition cable from the igniter to the control module. Replace if necessary.
2. Inspect the igniter ground wire for signs of deterioration. Replace if necessary.
3. Ensure the ignition cable and igniter ground wire are securely connected.

Check Control Wiring

1. Inspect all control wiring. Ensure wiring is in good condition and properly connected.

Check Control Settings (MCBA)

1. Set the control display to PARAMETER mode and check all boiler settings. Adjust settings as necessary.
2. Check any external limit control settings (if used). Adjust settings as necessary.

Check Control Settings (TriMax)

1. Review all boiler settings in the Heating & DHW EZ Setup menus. Adjust settings as necessary.
2. Check any external limit control settings (if used). Adjust settings as necessary.

Perform Start-up and Checkout Procedures

1. Start the unit and perform the start-up procedure as referenced in the Boiler Installation Manual.
2. Verify the cold water fill pressure is correct and the operating pressure of the boiler is within normal operating range.
3. Complete the checkout procedures as referenced in the Boiler Installation Manual.

Check Burner Flame

1. Inspect the burner flame through the observation port on the heat exchanger.

2. If flame pattern is not fully blue and covers the entire burner surface during high fire, shut the unit down and allow it to cool thoroughly before disassembly.
3. Close the external manual gas valve on the gas supply line and disconnect the gas piping and gas valve wire harness.
4. Remove the top jacket access panel.
5. Disconnect the wiring harness connectors from the blower and remove the blower retaining nuts. Remove the blower with venturi and gas valve from the unit.
6. Remove the mounting nuts securing the burner mounting plate to the heat exchanger and set aside.
7. Carefully remove the burner mounting plate assembly from the heat exchanger. Ensure combustion chamber insulation is not damaged during removal of burner mounting plate assembly. See WARNING on page 14.
8. Remove the burner head mounting screws and remove the burner head. Inspect the burner head for deterioration. Use compressed air or a vacuum to clean the burner head. Replace burner if necessary.
9. Remove the venturi and gas valve assembly from the blower.
10. Use a vacuum cleaner or compressed air to clean the interior of the blower and venturi. Inspect the venturi and blower to ensure they are clean and not damaged, replace if necessary.
11. Re-assemble the venturi and gas valve onto the blower. Ensure the venturi gasket is in good condition and positioned correctly. Replace gasket if necessary. Tighten screws evenly. See Table 1, page 14 for torque specifications.
12. Re-assemble the burner head onto the burner mounting plate. Ensure the burner head gasket is in good condition and positioned correctly. Replace gasket if necessary. Tighten screws evenly. See Table 1, page 14 for torque specifications.

PRESTIGE Solo 399

Service Parts Instructions

13. Remove the combustion chamber insulation from the heat exchanger and inspect for any signs of damage or deterioration. Replace combustion chamber insulation if necessary. See WARNING on page 14.
14. Install the combustion chamber insulation in the heat exchanger so that the sight glass and igniter cutout are orientated correctly.
15. Re-assemble the burner mounting plate assembly onto the heat exchanger. Ensure the burner plate gasket and combustion chamber insulation is in place and not damaged, replace gasket if necessary.

16. Check combustion chamber insulation alignment with the burner mounting plate. The combustion chamber insulation igniter cutout should align with the opening in the burner mounting plate. If not properly aligned, remove the burner mounting plate and reposition combustion chamber insulation.

NOTICE

Misalignment of combustion chamber insulation can cause unreliable boiler operation.

17. Hand tighten the burner mounting plate nuts to hold the burner plate in place. Once all mounting nuts are in place, use a wrench to tighten using an alternating pattern until the gasket is slightly compressed. See Table 1, page 14 for torque specifications.
18. Re-assemble the blower onto the burner mounting plate and reconnect the wiring harness connectors. Tighten nuts evenly. See Table 1, page 14 for torque specifications.
19. Re-assemble the gas supply connection and wire harness to the gas valve. See Fig. 7 for wire colors. Tighten the union using two wrenches. See Table 1, page 14 for torque specifications. Open the external manual gas valve. Check gas piping for any leaks and repair if necessary.

20. Reinstall top jacket access panel.

21. Place the unit back into service.

Check Flame Signal (MCBA)

1. The flame signal can be read from item E in the information mode. It should be a min. 3 μ A –DC.
2. Check the igniter for fouling or damaged insulation if a low flame signal is read.
3. Check ground wiring and continuity as a cause for low flame signal. Replace igniter and/or ignition cable if conditions are unsatisfactory.

PRESTIGE Solo 399

Service Parts Instructions

Check Flame Signal (TriMax)

1. The flame signal can be read from the boiler information screen. It should be a min. 1μ A –DC.
2. Check the igniter for fouling or damaged insulation if a low flame signal is read.
3. Check ground wiring and continuity as a cause for low flame signal. Replace igniter if conditions are unsatisfactory.

Check Combustion Levels

Perform a complete combustion check to ensure the following combustion levels are met at high and low inputs and the burner is operating at optimum conditions.

	Natural Gas	Propane
O ₂ Min.	2.30%	3.70%
O ₂ Max.	5.30%	5.20%
CO ₂ Min.	8.80%	10.00%
CO ₂ Max.	10.50%	11.00%
CO Max.	100 ppm	100 ppm

WARNING

The combustion testing and adjustments must be performed by a qualified installer, service agency or the gas supplier. All combustion measurements must be performed with calibrated equipment to ensure proper readings and accuracy.

WARNING

Failure to perform a complete combustion test at both high and low input rates may result in incomplete combustion and the production of carbon monoxide, which can cause severe personal injury, death or substantial property damage.

MCBA Instructions

1. Manually place the boiler into high fire mode by pressing the MODE button with “+” button simultaneously on the control panel display while in the standby (STBY) mode.

NOTICE

The control panel will display a H followed by the current boiler temperature when placed into high fire test mode.

2. If the combustion levels during high fire is outside the recommended combustion settings adjust the THROTTLE SCREW (see Fig. 7) as follows:

Counter-clockwise adjustment of the throttle screw at high fire:

O₂ decreases and CO₂ increases

Clockwise adjustment of the throttle screw at high fire:

O₂ increases and CO₂ decreases

3. Once the combustion level is set at high fire, manually place the boiler into low fire mode by pressing the MODE button with “-” button simultaneously on the control display while in the standby (STBY) mode.

NOTICE

The control panel will display a L followed by the current boiler temperature when placed into low fire test mode.

4. If the CO₂ combustion level at low fire is not within +/- 0.2% of the combustion level measured at high fire, remove the offset cover screw and adjust the **OFFSET SCREW** using a T40 Torx screwdriver (see Fig. 7) as follows:

Counter-clockwise adjustment of offset screw at low fire:

O₂ increases and CO₂ decreases

Clockwise adjustment of offset screw at low fire:

O₂ decreases and CO₂ increases

PRESTIGE Solo 399

Service Parts Instructions

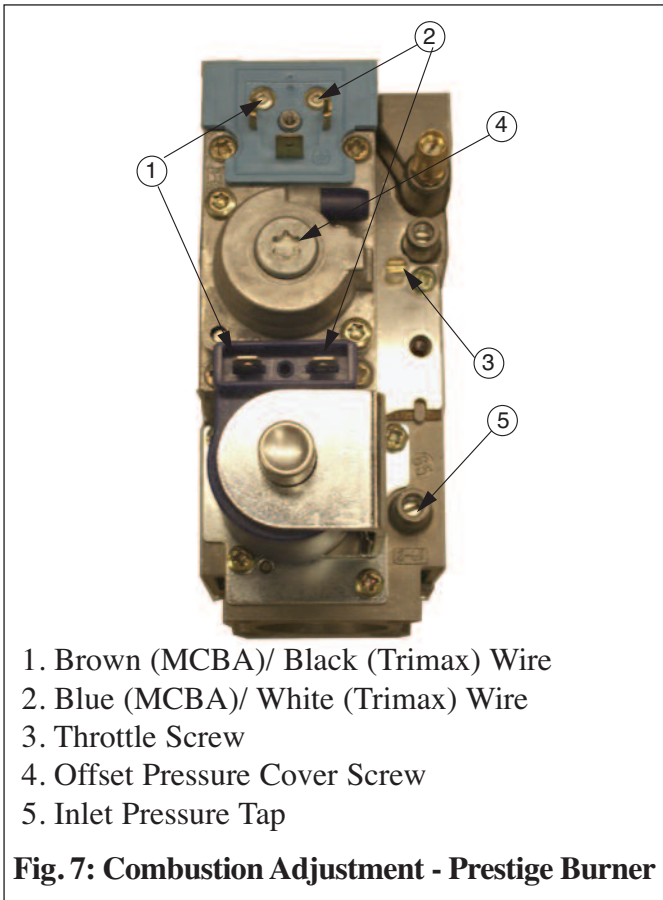

1. Brown (MCBA)/ Black (Trimax) Wire
2. Blue (MCBA)/ White (Trimax) Wire
3. Throttle Screw
4. Offset Pressure Cover Screw
5. Inlet Pressure Tap

Fig. 7: Combustion Adjustment - Prestige Burner

TriMax Instructions

1. Press the round **INSTALLER** button. See Fig. 8.

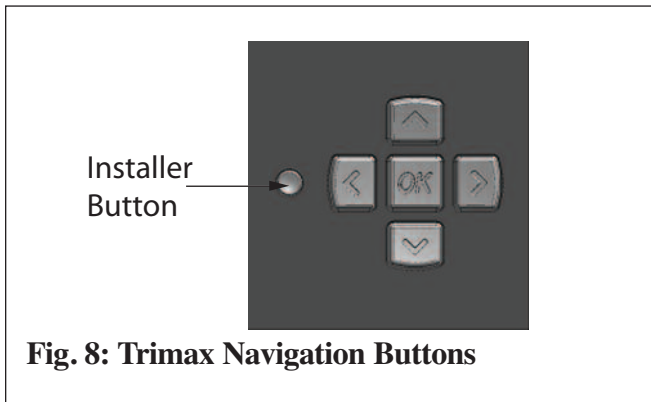

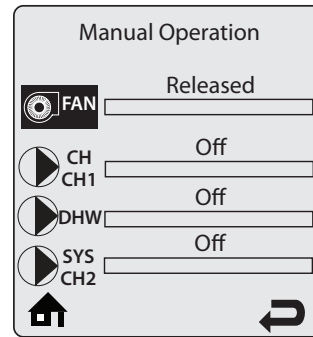

Fig. 8: Trimax Navigation Buttons

2. Enter the installer access code “054” by using the **LEFT** and **RIGHT** buttons to select a digit and the **UP** and **DOWN** buttons to change the digit. Press the **OK** button to enter the access code.

3. Press the **RIGHT** button to highlight the Manual Operation icon  then press the **OK** button.
4. Press the **OK** button while the FAN icon is highlighted to manually fire the burner and power the CH circulator.



NOTICE

An adequate CH load must be present to dissipate the heat generated during the combustion test. If an adequate CH load is not available, an indirect water heater can be used to dissipate the heat by creating a DHW call which will enable the DHW circulator.

5. Press the **RIGHT** button to adjust the firing rate to high fire (100%). Hold down the **RIGHT** button to rapidly increase the firing rate.
6. If the combustion levels during high fire (100%) are outside the recommended combustion settings adjust the **THROTTLE SCREW** (see Fig. 7) using a flat-blade screwdriver as follows:

Counter-clockwise adjustment of the THROTTLE SCREW at High Fire:

O₂ decreases and CO₂ increases

Clockwise adjustment of the THROTTLE SCREW at High Fire:

O₂ increases and CO₂ decreases

7. Once the combustion level is set at high fire (100%), manually place the boiler into low fire (1%) mode by pressing the **LEFT** button to adjust firing rate down.

PRESTIGE Solo 399

Service Parts Instructions

8. If the CO₂ combustion level at low fire (1%) is not within +/-0.2% of the combustion level measured at high fire, remove the offset cover screw and adjust the OFFSET SCREW using a T40 Torx screwdriver (see Fig. 7) as follows:

Counter-clockwise adjustment of OFFSET SCREW at Low Fire:

O₂ increases and CO₂ decreases

Clockwise adjustment of OFFSET SCREW at Low Fire:

O₂ decreases and CO₂ increases

9. Press the **OK** button while the fan icon is highlighted to shutdown the burner.
10. Press the **DOWN** button to highlight the home screen icon  to exit the service mode.

Check Flue Gas Temperature (MCBA)

1. Manually place the boiler into high fire mode by pressing the MODE button with “+” button simultaneously on the control panel display while in the standby (STBY) mode.
2. Press the MODE button to enter Information mode. Press the STEP button to advance through the information items.
3. The flue gas temperature is indicated on the display when the first digit is 5 in the Information mode. The measured temperature (shown as the last 3 digits) should not be more than 54°F [30°C] higher than the measured supply water temperature.
4. The measured supply water temperature is indicated in the information display when the first digit is 1 and the temperature shown as the last 3 digits.
5. If the measured flue gas temperature is higher than 54°F [30°C] over the supply water temperature, shut the boiler down and follow the procedures listed below to clean the flue & water sides of the heat exchanger.

Check Flue Gas Temperature (TriMax)

1. Manually place the boiler into high fire. See TriMax combustion test instructions for procedure.
2. Navigate to the Boiler Information Menu to observe the flue gas temperature.
3. If the measured flue gas temperature is higher than 54°F [30°C] over the supply water temperature, shut the boiler down and follow the procedures listed below to clean the flue & water sides of the heat exchanger.

Clean Heat Exchanger (Flue side)

1. Shut the unit down and allow it to cool thoroughly before disassembly.
2. Close the external manual gas valve on the gas supply line and disconnect the gas piping and gas valve wire harness.
3. Remove the top jacket access panel.
4. Disconnect the wiring harness connectors from the blower and remove the blower retaining nuts. Remove the blower with venturi and gas valve from the unit.
5. Remove the mounting nuts securing the burner mounting plate to the heat exchanger and set aside.
6. Carefully remove the burner mounting plate assembly from the heat exchanger. Ensure combustion chamber insulation is not damaged during removal of burner mounting plate assembly. See WARNING on page 14.
7. Carefully remove the combustion chamber insulation from the heat exchanger and inspect for any signs of damage or deterioration. Replace combustion chamber insulation if necessary. See WARNING on page 14.
8. Use a vacuum cleaner, compressed air or water to remove any accumulation from the heat exchanger flue ways. Do not use any solvent.
9. Install the combustion chamber insulation in the heat exchanger so that the sight glass and igniter cutout are orientated correctly.

PRESTIGE Solo 399

Service Parts Instructions

10. Re-assemble the burner mounting plate assembly onto the heat exchanger. Ensure the burner plate gasket and combustion chamber insulation is in place and not damaged, replace gasket if necessary.
11. Check combustion chamber insulation alignment with the burner mounting plate. The combustion chamber insulation igniter cutout should align with the opening in the burner mounting plate. If not properly aligned, remove the burner mounting plate and reposition combustion chamber insulation.

NOTICE

Misalignment of combustion chamber insulation can cause unreliable boiler operation.

12. Hand tighten the burner mounting plate nuts to hold the burner plate in place. Once all mounting nuts are in place, use a wrench to tighten using an alternating pattern until the gasket is slightly compressed. See Table 1, page 14 for torque specifications.
13. Re-assemble the blower onto the burner mounting plate and reconnect the wiring harness connectors. Tighten nuts evenly. See Table 1, page 14 for torque specifications.
14. Re-assemble the gas supply connection and wire harness to the gas valve. See Fig. 7 for wire colors. Tighten the union using two wrenches. See Table 1, page 14 for torque specifications. Open the external manual gas valve. Check gas piping for any leaks and repair if necessary.
15. Reinstall top jacket access panel.

Clean Heat Exchanger (Water side)

1. In case of “Dirty/Black” boiler water, or when additional piping is installed on the system, it is recommended to carry out the procedures below to clean the water side of the heat exchanger.
2. Close isolation valves on the boiler water piping to isolate the boiler from the heating system.
3. Attach a hose to the boiler drain valve and flush the boiler thoroughly with fresh water by using the purge valves to allow water to enter through the make-up water line to the boiler.
4. Once the boiler heat exchanger has been completely flushed. Follow instructions provided by boiler cleaning agent manufacturer to clean and flush the existing system. Use an approved inhibitor to protect the boiler and heating system. Approved boiler cleaning agents: Fernox F1 and F3, Sentinel boiler treatment chemicals.
5. After completion of boiler flushing and cleaning and treatment with inhibitor, perform a combustion test and check flue gas temperatures.
6. Return the boiler and system piping back in to operation.

PRESTIGE Solo 399

Service Parts Instructions

Maintenance Check List

Description	
Inspect boiler jacket area: clean and vacuum as needed	
Clean condensate drain and fill with fresh water	
Check for leaks: water, gas, flue and condensate	
Verify vent piping is in good condition, sealed tight, well supported and unobstructed	
Verify combustion air piping is in good condition, sealed tight, well supported and unobstructed	
Verify area surrounding unit is free from contaminating products and flammable vapors or liquids	
Check boiler pressure, piping and expansion tank, air vent and relief valve	
Check boiler water for clarity and pH	
Check pH of condensate neutralizer if applicable	
Check control settings	
Check igniter: sand off any white oxide, clean and reposition	
Check ignition cable and ground wiring to igniter	
Check sight glass assembly	
Check all control wiring and connections	
Check burner flame pattern (stable and uniform)	
Verify boiler input by clocking the gas meter (NG only). Provides indication of restricted burner	
Perform combustion test and record values:	
High Fire Results:	
Gas Type: NG or LP Gas Pressure: _____ Inches WC CO2: _____ % CO: _____ ppm	
Check boiler efficiency as outlined below:	
Record supply and flue temps during high fire test	
Verify and record flame rectification signal	
Supply Temperature	°F
Flue Temperature	°F
Compute difference between Flue Temp- Supply Temp	°F
If difference is greater than 54°F [30°C], clean flue side and water side of heat exchanger	
Low Fire Results:	
Gas Type: NG or LP Gas Pressure: _____ Inches WC CO2: _____ % CO: _____ ppm	
Cleaning Flue Side of Heat Exchanger (Replace gaskets as needed)	
Cleaning of Water Side of Heat Exchanger (if required)	

PRESTIGE Solo 399

Service Parts Instructions

Handling Previously Fired Combustion Chamber Insulation



The combustion chamber insulation contains ceramic fibers, which are classified as a possible human carcinogen. When exposed to extremely high temperatures, the ceramic fibers, which contain crystalline silica, can be converted into cristobalite.

Avoid Breathing and Contact with Skin and Eyes

When removing or repairing the combustion chamber insulation follow these precaution measures:

1. Use a NIOSH approved respirator which meets OSHA requirements for cristobalite dust, similar to N95. Contact NIOSH at 1-800-356-4676 or on the web at www.cdc.gov/niosh for latest recommendations.
2. Wear long sleeved, loose fitting clothing, gloves and eyes protection.
3. Assure adequate ventilation.
4. Wash with soap and water after contact.
5. Wash potentially contaminated clothes separately from other laundry and rinse washing machine thoroughly.
6. Discard used insulation in an air tight plastic bag.

NIOSH Stated First Aid:

Eye/Skin: Immediately irrigate
Breathing: Clean fresh air

Table 1: Torque Specifications

Assembly Screws	Torque Specifications	
	Min. Inch- Pounds	Max. Inch- Pounds
Sight Glass	11	13
Burner Head	27	31
Igniter	27	31
Gas Valve Couplings	27	31
Blower - Outlet	27	31
Venturi to Gas Valve	31	35
Venturi to Blower	31	35
Burner Plate	44	59