



CTRLMax Control System

- Graphical display with 5 navigation buttons
- EZ Setup allows quick and easy boiler settings adjustment
- Flexible configuration of 4 circulator outputs for custom applications
- Outdoor temperature reset to maximize efficiency
- Accepts two space heating call inputs with independent outdoor reset curves
- Domestic hot water priority with optional time-out
- Integrated cascade control for up to 6 Exalt boilers
- 0-10 VDC Modulation input
- Modbus building management system (BMS) interface, LonWorks® and BACnet® interface optional
- Adjustable warm weather shutdown
- Adjustable boiler freeze protection
- Logging function records sensor readings for system optimization and troubleshooting
- Describes lockouts in plain English and suggests solutions while storing last 8 errors

Exalt Floor Standing 110 Solo Features

- Heavy duty construction for floor standing installation
- Approved for zero clearance to combustibles
- 2" PVC, CPVC, PP venting up to 28 equivalent feet
- 3" PVC, CPVC, PP, or AL29-4C venting up to 100 equivalent feet
- Left or Right side optional boiler connections
- Left, Right, Top, or Back gas connections
- Up to 12 year limited warranty on heat exchanger
- Up to 6 year limited warranty on parts, except igniter
- Up to 3 year labor allowance

Approvals

- 95% AFUE Efficiency
- ENERGY STAR Qualified
- ANSI Z21.13 and CSA 4.9 Boiler Standards Compliance
- ASME Boiler Certification – ASME "H" Stamp

Stainless Steel Fire Tube Heat Exchanger

- 439 Stainless Steel heat exchanger construction for corrosion resistance
- High water content provides stable temperature control
- Self cleaning flue ways reduce maintenance
- Suitable for use with propylene glycol up to 50% concentration

Standard Equipment

- Factory fitted remote Wifi monitoring
- Stainless steel premix burner
- Direct spark ignition with variable speed blower
- Full modulation with turndown ratio of 8:1
- Hydraulic Separator with dirt and air separation
- Automatic air vent
- ASME 30 PSI pressure relief valve
- Temperature and Pressure gauge
- Outdoor temperature sensor
- Automatic low water cutoff feature with early warning
- High temperature manual reset limit safety control
- Terminal block for circulator output
- Low voltage terminal strip with removable jumpers for manual or automatic reset limits
- Swing up control for easy access and servicing
- Polypropylene condensate pan and internal flue pipe
- 3 in 1 Universal vent adapter directly accepts PVC/CPVC, Polypropylene, Stainless steel connections with test ports
- Additional external 110V socket

Project / Location: _____ Date: _____

Consulting Engineer / Architect: _____

Mechanical Contractor: _____

Boiler Dimensions

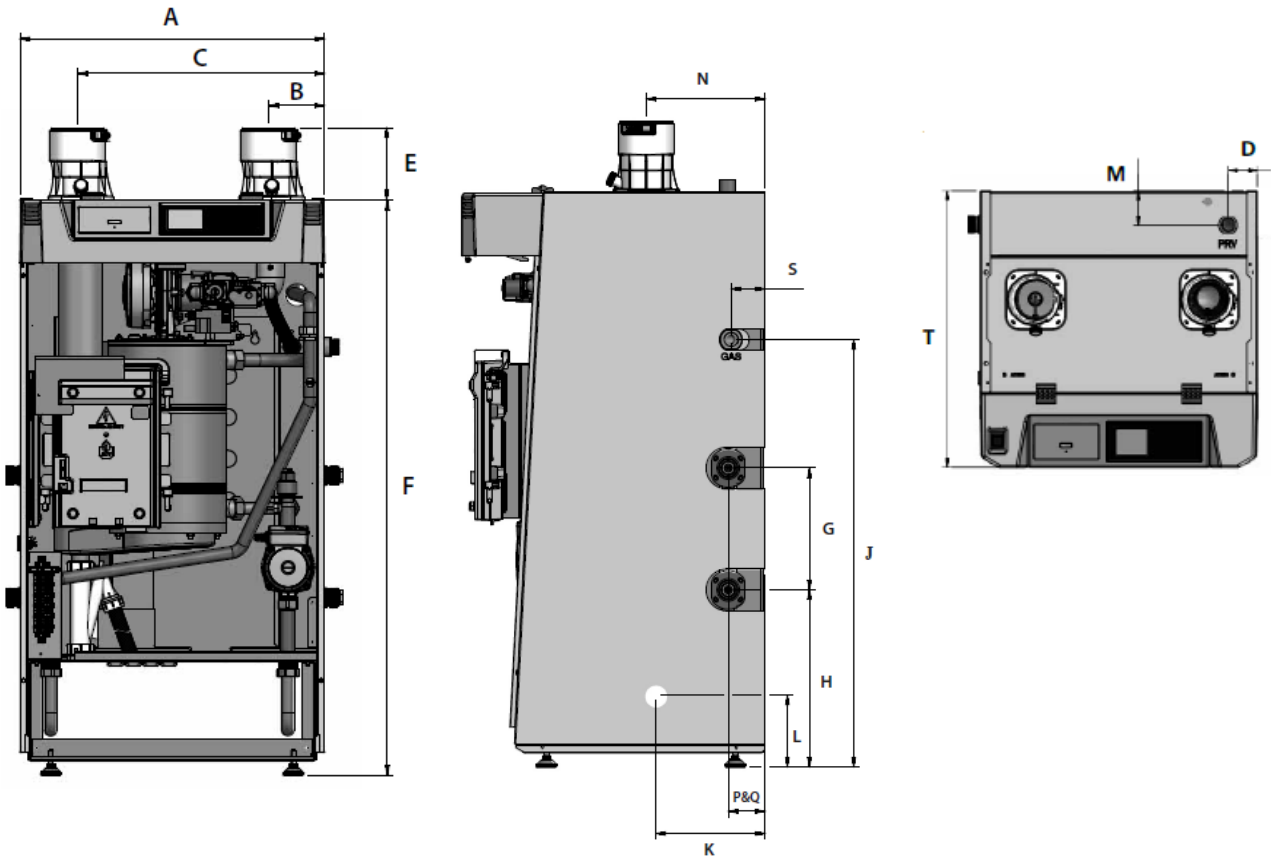

Boiler Performance

Exalt Floor Standing Boiler						Details				
Model Number	Input, MBH		Heating Capacity, MBH	Net AHRI Rating, MBH	AFUE	Boiler Connections	Air Inlet	Vent Outlet	Gas Connections	Shipping Weight
	Min	Max								
EXFS110S	13.75	110	102	89	95%	1"	3"	3"	3/4"	196 lbs

- The Net AHRI Water Ratings shown are based on a piping and pickup allowance of 1.15.
- IdealUSA should be consulted before selecting a boiler for installations having unusual piping and pickup requirements, such as intermittent system operation, extensive piping systems, etc.
- The ratings have been determined under the provisions governing forced draft burners.

Boiler Dimensions

Dimensions – In [mm]														
A	B	C	D	E	F	G	H	J	K	L	M, P, Q	N	S	T
21 5/8" [550]	4" [101]	17 1/2" [445]	2 1/4" [58]	5 1/8" [130]	40 3/4" [1036]	8 5/8 [220]	12 5/8" [320]	30 3/8" [771]	7 3/4" [198]	6" [150]	2 5/8" [68]	8 1/2" [215]	2 1/2" [62]	21 5/8" [548]