Freeze Protection Switch Replacement Kit for Hydronic Air Handler



Kit Part Numbers: AHPARTS01

Parts List

1. Freeze protection Switch

Recommended tools:

- Screwdriver #3 slotted
- Screwdriver #3 Phillips
- 5/16" Nut Driver
- Wire Cutters
- Pliers



WARNING

Indicates a potentially hazardous situation which, if ignored, can result in serious injury or substantial property damage.

NOTICE

Indicates special instructions on installation, operation or maintenance, which are important to equipment but not related to personal injury hazards.

WARNING

Failure to follow instructions below can result in severe personal injury or damage if ignored.

- Instructions are for a qualified installer/ service technician.
- Read all instructions before proceeding.
- Follow instructions in proper order.

WARNING

For your safety, turn off electrical power supply at service panel before proceeding to avoid possible electrical shock hazard. Failure to do so can cause severe personal injury or death.

Freeze Protection Switch Replacement Kit for Hydronic Air Handler

Removal of FP-Switch

1. Disconnect electrical power supply to the Hydronic Air Handler.
2. Remove eight 5/16" hex head screws and remove front panel.

NOTICE

Use care not to damage or scratch the front panel when removing from cabinet.

4. Lay front panel away from unit and expose the FP-Switch and control wiring.
5. Remove retainer clip holding FP-Switch to the Air Handler Hydronic Coil.
6. Use pliers to remove two strain relief bushings and pull sensor back through control chassis.
7. Disconnect wires from FP-Switch from the control circuit. See: Fig. 1.

Installation of FP-Switch

1. Mount the new FP-Switch onto the coil and secure with retainer clip
2. Pull FP-Switch wires through chassis 3/8" port and secure with two strain relief bushings.
3. Reattached FP-Switch to the control circuit. See Fig: 1.
4. Reattached the front panel and secure with existing eight 5/16" Hex Head screws.
5. Turn the power on the unit and return the Hydronic Air Handler to service.

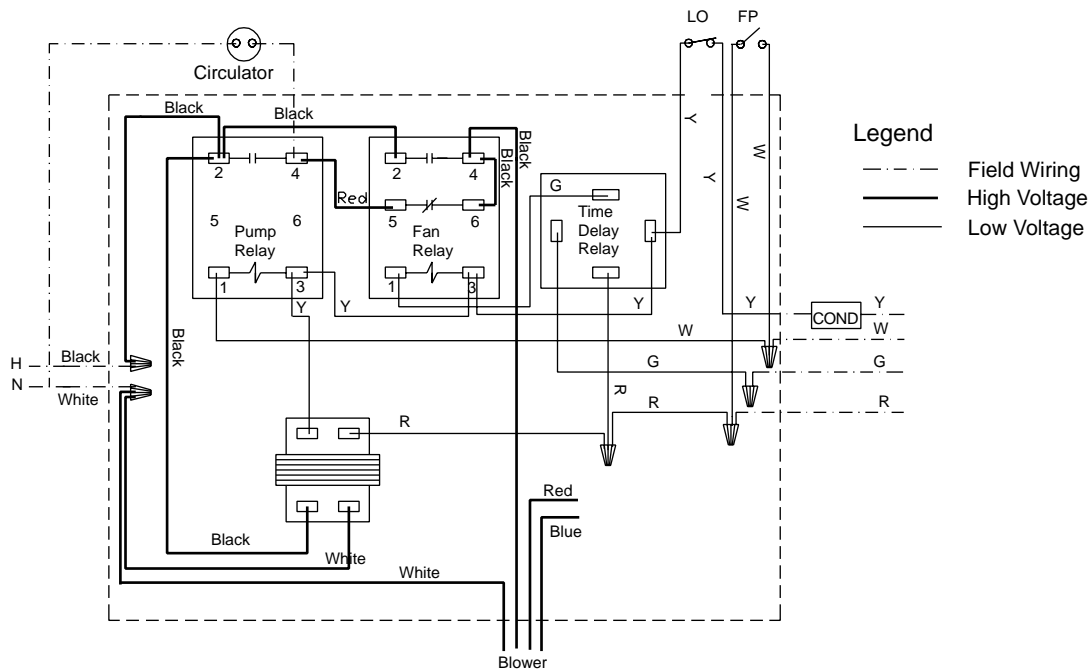

Fig. 1: Factory Wiring Diagram