



# APPLICATION GUIDE

Exalt FSB 110-155-199 & FSB Combi 155-199

## NOTICE

- This manual is applicable to all Exalt floor standing boilers with display software version 0.40 or later.
- If this guide does not apply to your boiler, Please visit [idealusa.com](http://idealusa.com) to obtain the correct application guide.
- Customer must register unit within thirty (30) days of installation in order to gain warranty coverage. See Warranty Card for details.
- Leave all documentation received with appliance with the owner for future reference.

## WARNING

- This document is intended to be used by a factory trained and qualified heating contractor or service technician only. Read all Instructions within this document and within the relevant Boiler Installation and Maintenance Manual before proceeding. It is recommended to follow the procedures in the steps given. Skipping or missing procedural steps could result in substantial property damage, serious injury, or death.
  - To maintain the safety & longevity of your appliance, read and follow the Installation and Maintenance Manual prior to installation.
  - If the information in this manual is not followed exactly, a fire or explosion may result causing substantial property damage, serious injury, or death.
- ### FOR YOUR SAFETY
- Do not store or use gasoline or other flammable vapors and liquids in the vicinity of this or any other appliance.
  - WHAT TO DO IF YOU SMELL GAS
    - Do not try to light any appliance
    - Do not touch any electrical switch; do not use any phone in your building.
    - Immediately call your gas supplier from a neighbor's phone. Follow the gas supplier's instructions.
    - If you cannot reach your gas supplier, call the fire department.



# Exalt Application Guide

## Sections

1.Boiler Pump Presets .....	3
2.Flexible Pump Configuration.....	5
3.Exalt Solo Piping Diagrams .....	7
4.Exalt Combi Piping Diagrams .....	14

## Figures

Fig. 1: Installer Button .....	3
Fig. 2: Installer Access Code .....	3
Fig. 3: CH & DHW Settings .....	3
Fig. 4: Boiler Settings.....	3
Fig. 5: Pump Settings.....	3
Fig. 6: Preset Pump Configuration.....	3
Fig. 7: Preset Pump Configuration.....	3
Fig. 8: Piping Layout Legend .....	4
Fig. 9: Installer Button .....	5
Fig. 10: Installer Access Code.....	5
Fig. 11: CH & DHW Settings.....	5
Fig. 12: Boiler Settings .....	5
Fig. 13: Pump Settings .....	5
Fig. 14: Flexible Pump Config.....	5
Fig. 15: Flex. Relays.....	6
Fig. 16: Flex. Relay 1 Settings.....	6
Fig. 17: Flex. Relay 1 Save Option.....	6
Fig. 18: Exalt Solo Near Boiler Piping with Hydraulic Separator .....	7
Fig. 19: Exalt Solo - Multiple Temperature Zones with Circulators .....	8
Fig. 20: Exalt Solo - Multiple Zones with Circulators.....	9
Fig. 21: Exalt Solo - Piping with Zone Valves and Zone Valve Control Panel .....	10
Fig. 22: Exalt Solo - Single Zone with Circulator .....	11
Fig. 23: Exalt Solo - Piping with Zone Valves .....	12
Fig. 24: Exalt Solo - Cascade Layout.....	13
Fig. 25: Exalt Combi Near Boiler Piping with Hydraulic Separator.....	14
Fig. 26: Exalt Combi - Multiple Zones with Circulators .....	15
Fig. 27: Exalt Combi - Single Zones with Circulator.....	16
Fig. 28: Exalt Combi - Multiple Temperature Zones with Circulators.....	17
Fig. 29: Exalt Combi - Multiple Zones with Zone Valves .....	18
Fig. 30: Exalt Combi - Multiple Zones with Zone Valves and Zone Valve Control Panel .....	19

## Tables

Table 1: Exalt Preset Pump Configurations .....	4
---	---

# Exalt Application Guide

## 1. Boiler Pump Presets

The boiler comes preconfigured for several preset pump outputs.

1. To access the Installer screen, touching simultaneously the up and down soft keys for 3 seconds as shown in Fig. 1.

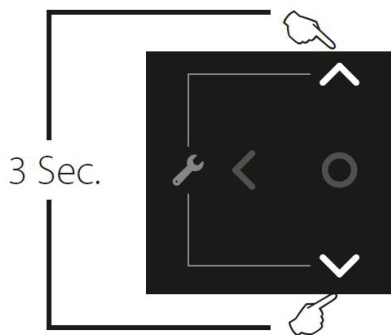

Fig. 1: Installer Button

2. Enter the installer access code "054" by using the **LEFT** and **RIGHT** buttons to select a digit and the **UP** and **DOWN** buttons to change the digit. Press the OK button to enter the access code.



Fig. 2: Installer Access Code

3. Press the OK button while the **CH & DHW Settings** icon is highlighted.

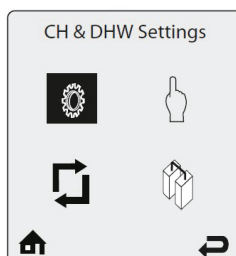

Fig. 3: CH & DHW Settings

4. Press the OK button while the **Boiler Settings** icon is highlighted.

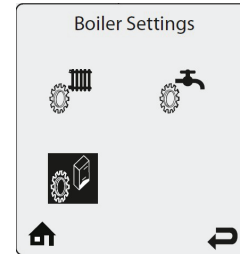

Fig. 4: Boiler Settings

5. Press the OK button while the **Pump Settings** option is highlighted.

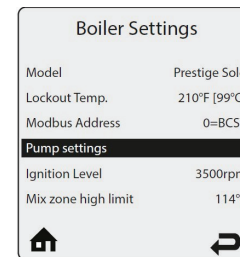

Fig. 5: Pump Settings

6. Press the OK button while the **Pump Settings** option is highlighted.

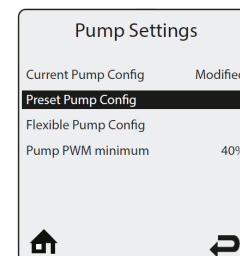

Fig. 6: Preset Pump Configuration

7. Scroll down the preset pump list and select one of the following options shown in Table 1.

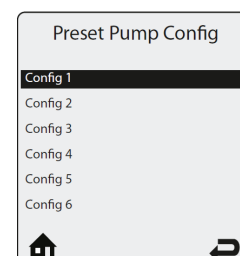

Fig. 7: Preset Pump Configuration

# Exalt Application Guide

Table 1: Exalt Preset Pump Configurations

Preset Configuration	Boiler Pump Flex 1	CH1 Pump Flex 5	CH2 Pump Flex 3	DHW Pump Flex 2
A	CH1 Call CH2 Call DHW Call	CH1 Call CH2 Call		DHW Call
B & C Out of the box setting	CH1 Call CH2 Call DHW Call	CH1 Call	CH2 Call	DHW Call
D	CH1 Call CH2 Call DHW Call	CH1 Call CH2 Call	CH1 Call CH2 Call	DHW Call
E	CH1 Call CH2 Call	CH2 Call	CH2 Call	DHW Call
F	CH1 Call CH2 Call	CH1 Call CH2 Call	CH1 Call CH2 Call	DHW Call

Note: Other Presets are shown as available. These are non functional in the Exalt Boilers

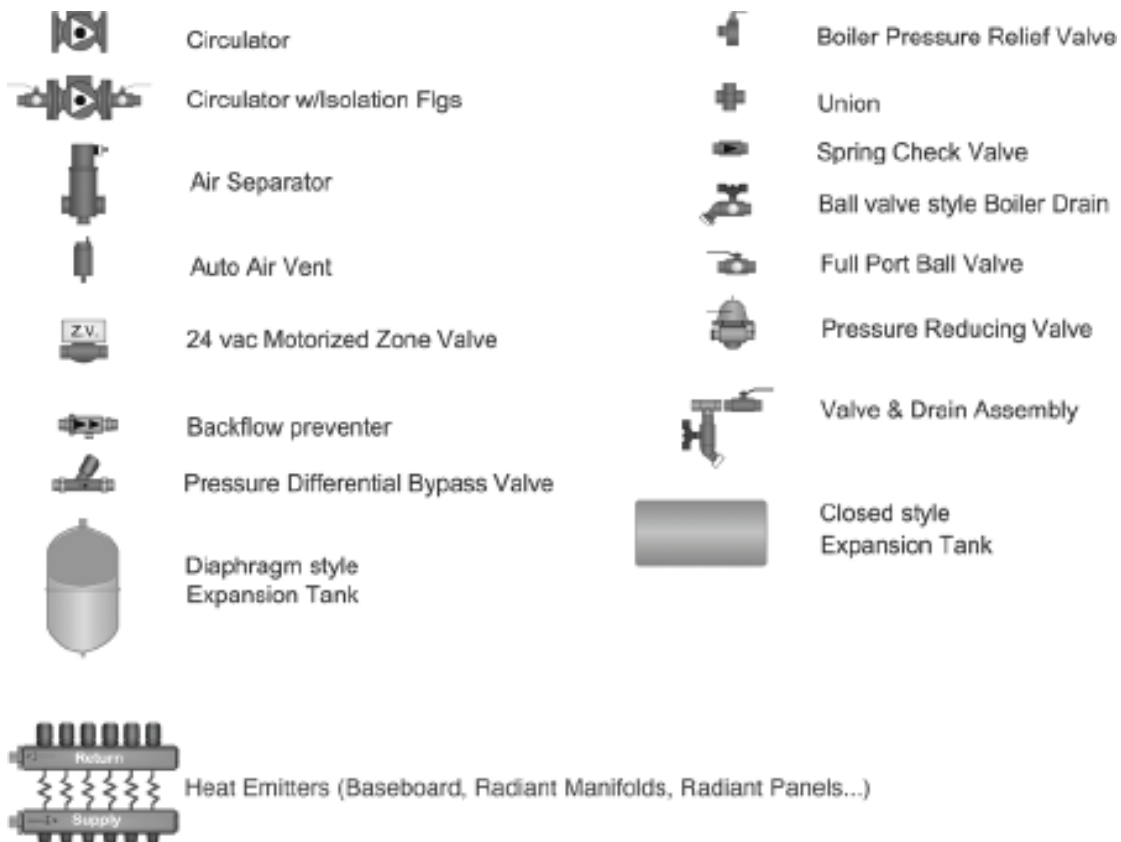

Fig. 8: Piping Layout Legend

# Exalt Application Guide

## 2. Flexible Pump Configuration

This allows the installer to customize the flexible Pump Output (relays) to a specific installation arrangement that is not addressed in the Preset Pump Configuration options. There is a total of four Pump Output(relays) that must be set.

1. To access the Installer screen, touching simultaneously the up and down soft keys for 3 seconds as shown in Fig. 9.

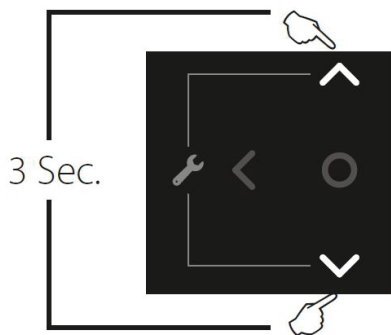

Fig. 9: Installer Button

2. Enter the installer access code "054" by using the **LEFT** and **RIGHT** buttons to select a digit and the **UP** and **DOWN** buttons to change the digit. Press the OK button to enter the access code.



Fig. 10: Installer Access Code

3. Press the OK button while the **CH & DHW Settings** icon is highlighted.

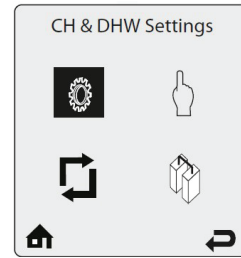

Fig. 11: CH & DHW Settings

4. Press the OK button while the **Boiler Settings** icon is highlighted.

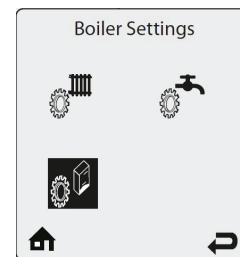

Fig. 12: Boiler Settings

5. Press the OK button while the **Pump Settings** option is highlighted.

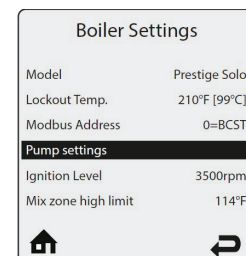

Fig. 13: Pump Settings

6. Press the OK button while **Flexible Pump Config** option is highlighted.

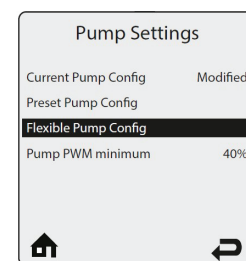

Fig. 14: Flexible Pump Config

# Exalt Application Guide

- A list of 4 Flex Relays are clickable. These are the Boiler actions to be edited.

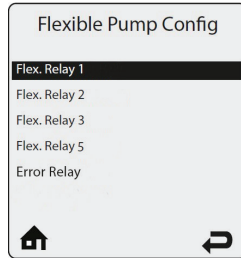

Fig. 15: Flex. Relays

- When selecting Flex Relay 1, the boiler pump actions are being edited.
  - When selecting Flex Relay 2, the DHW pump actions are being edited.
  - When selecting Flex Relay 3, the CH2 pump actions are being edited.
  - When selecting Flex Relay 5, the CH1 pump actions are being edited.
- Select the relay to be changed. Choose whether the relay will be on or off for any of the following calls: *CH1*, *CH2*, *DHW*, *MIX OPEN*, *MIX CLOSE*, *ERROR*, *FLAME*.

- When selecting CH1, the relay is activated at CH1 demand.
- When selecting CH2, the relay is activated at CH2 demand.
- When selecting DHW, the relay is activated at DHW demand.
- Mix Open is not functional in the Exalt Boilers.
- Mix Close is not functional in the Exalt Boilers.
- When selecting ERROR, the relay is activated on error.
- When selecting FLAME, the relay is activated when appliance is running and a flame signal has been detected.

- Once the Relay's actions have been selected, scroll down and hit enter on the **Save and Exit** option at the bottom. This relay shown in Fig. 16 is set to turn on the pump wired to the boiler pump terminal for CH1, CH2 and DHW calls.

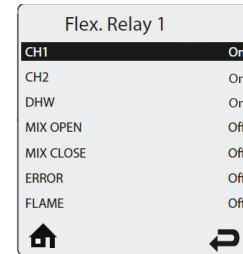

Fig. 16: Flex. Relay 1 Settings

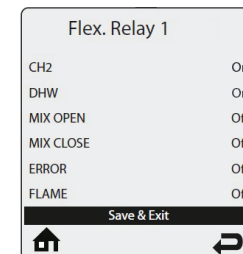

Fig. 17: Flex. Relay 1 Save Option

## NOTICE

*The options will not be saved when quick exiting (hitting the house or back arrow at the bottom of the menu).*

# Exalt Application Guide

## 3. Exalt Solo Piping Diagrams

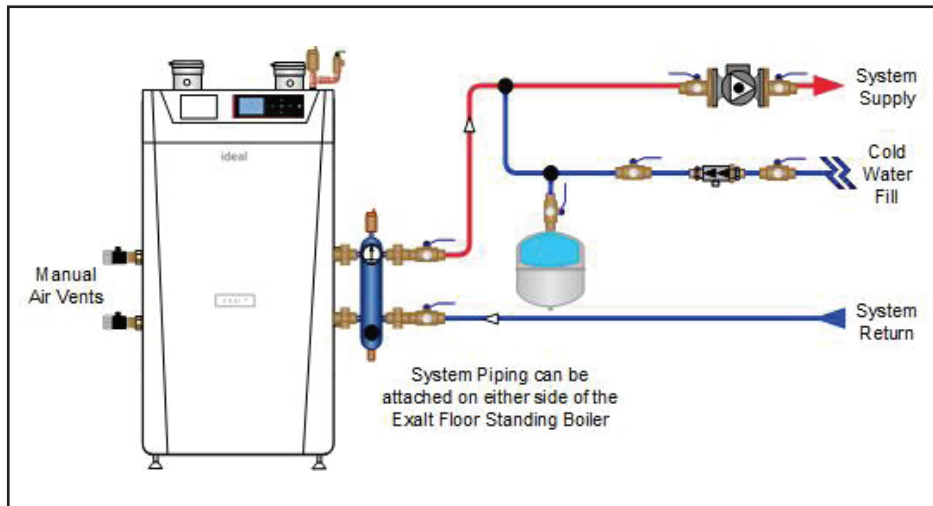

Fig. 18: Exalt Solo Near Boiler Piping with Hydraulic Separator

# Exalt Application Guide

## Preset B Pump Configuration

Heat Call	Boiler Pump	CH1 Pump	CH2 Pump	DHW Pump
CH1	ON	ON	OFF	OFF
CH2	ON	OFF	ON	OFF
DHW	ON	OFF	OFF	ON

Note: the boiler is set up in this configuration out of the box

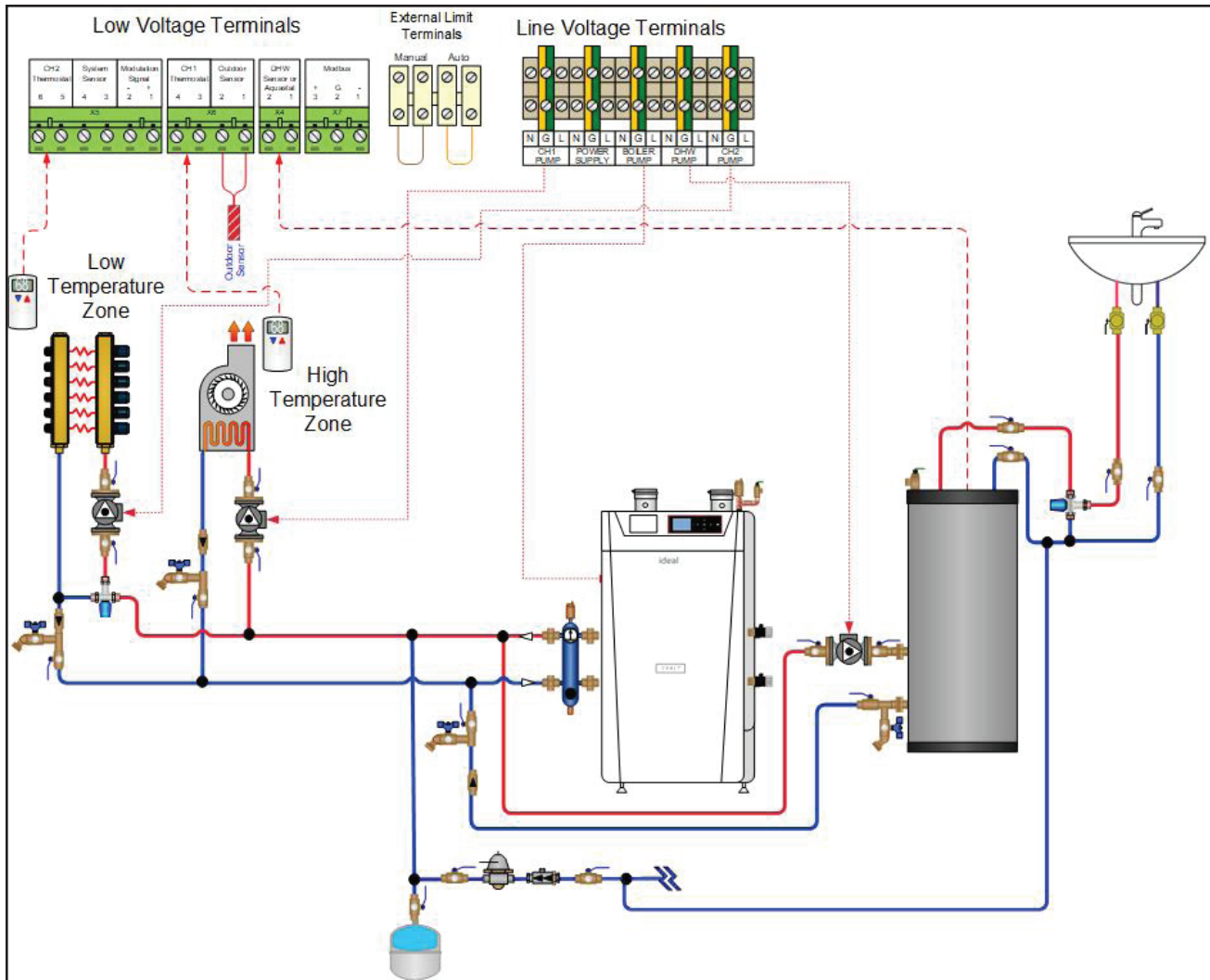

Fig. 19: Exalt Solo - Multiple Temperature Zones with Circulators

### NOTICE

Piping layout is shown with a Hydraulic Separator.

Layout is shown with separate Circulator and check valve. If using a circulator with internal check valve, the corresponding check valve is unnecessary.



# Exalt Application Guide

## Preset B Pump Configuration

Heat Call	Boiler Pump	CH1 Pump	CH2 Pump	DHW Pump
CH1	ON	ON	OFF	OFF
CH2	ON	OFF	ON	OFF
DHW	ON	OFF	OFF	ON

Note: the boiler is set up in this configuration out of the box

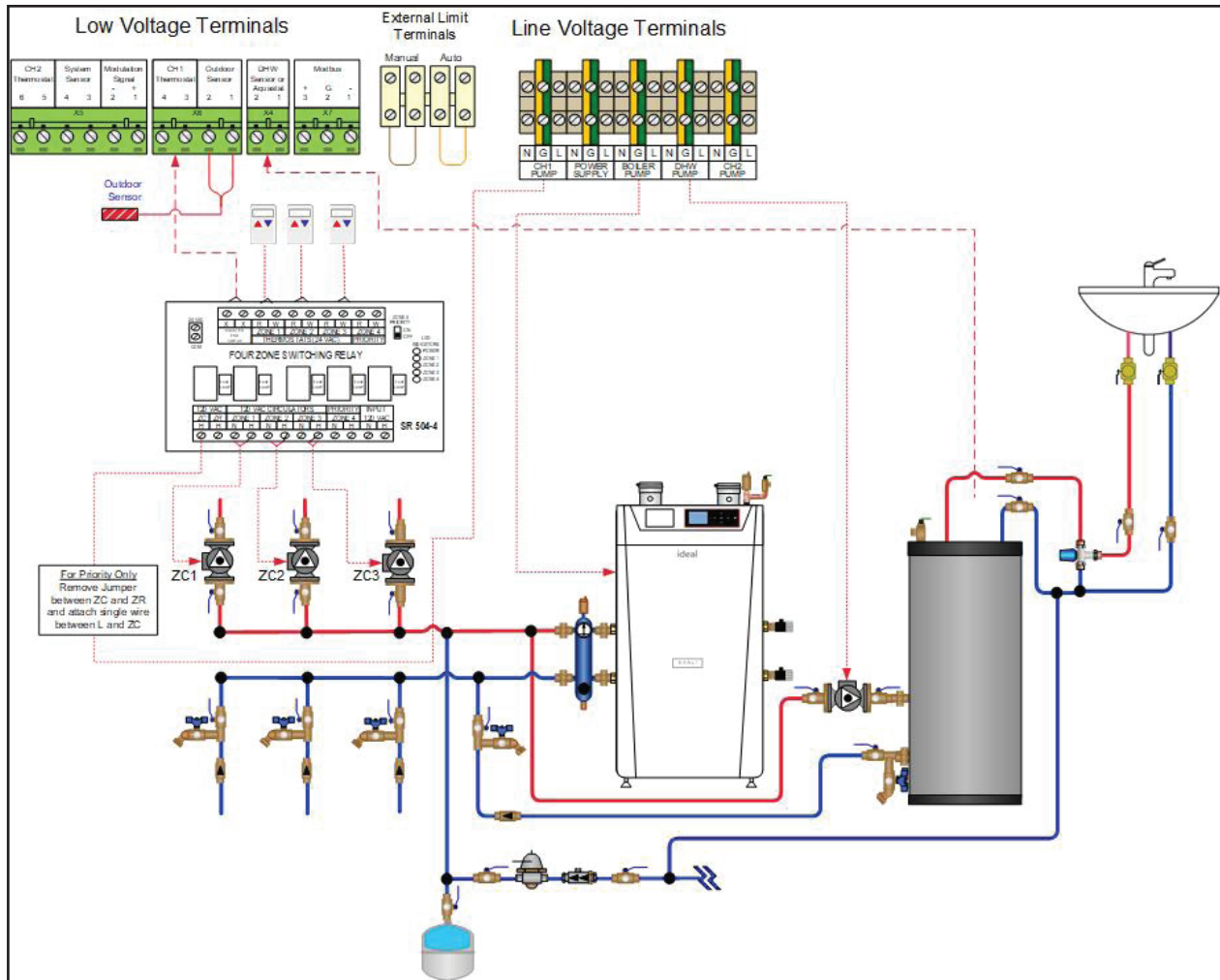

Fig. 20: Exalt Solo - Multiple Zones with Circulators

### NOTICE

Piping layout is shown with a Hydraulic Separator.

Layout is shown with separate Circulator and check valve. If using a circulator with internal check valve, the corresponding check valve is unnecessary.

# Exalt Application Guide

## Preset B Pump Configuration

Heat Call	Boiler Pump	CH1 Pump	CH2 Pump	DHW Pump
CH1	ON	ON	OFF	OFF
CH2	ON	OFF	ON	OFF
DHW	ON	OFF	OFF	ON

Note: the boiler is set up in this configuration out of the box

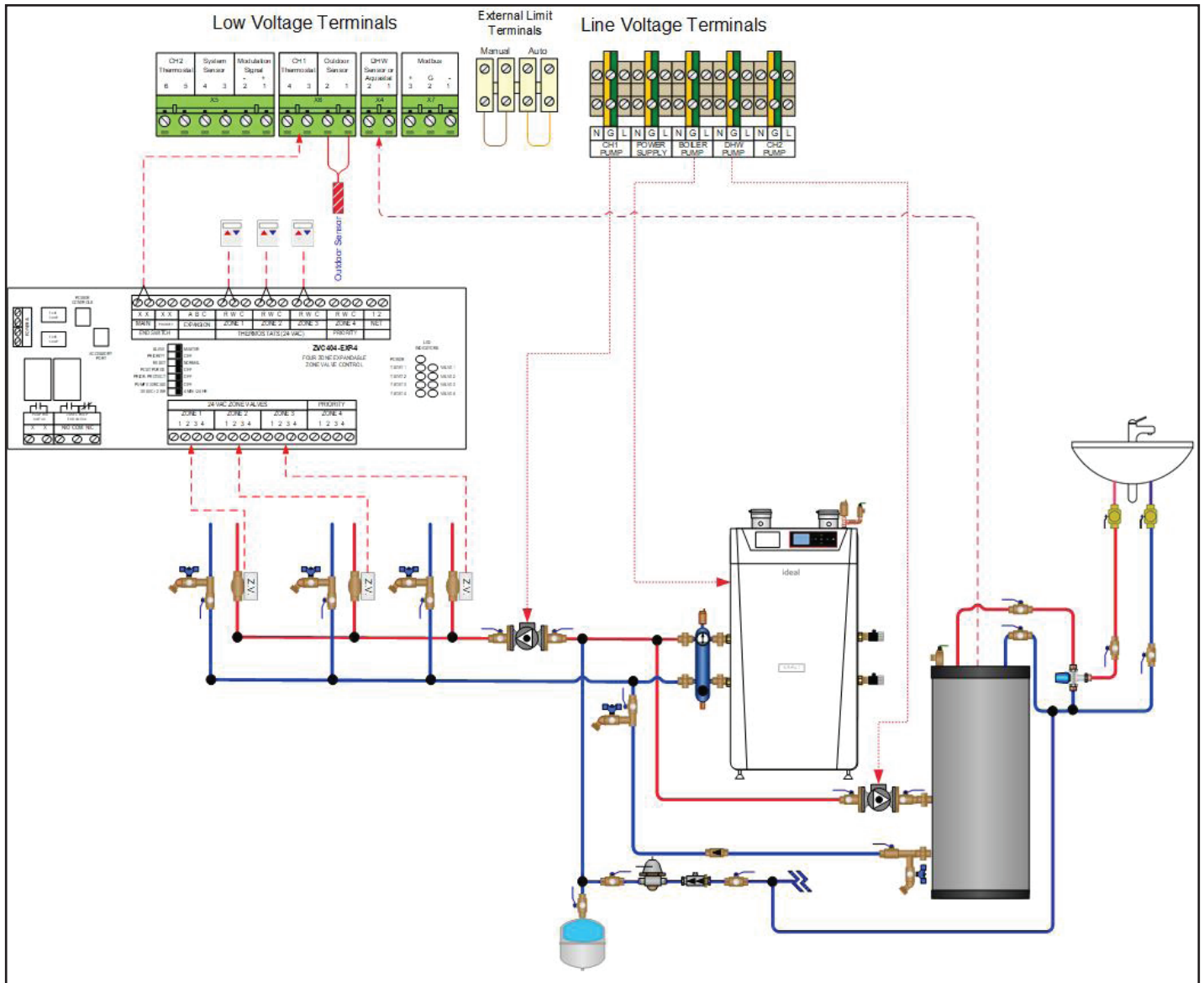

Fig. 21: Exalt Solo - Piping with Zone Valves and Zone Valve Control Panel

### NOTICE

Piping layout is shown with a Hydraulic Separator.

# Exalt Application Guide

## Preset B Pump Configuration

Heat Call	Boiler Pump	CH1 Pump	CH2 Pump	DHW Pump
CH1	ON	ON	OFF	OFF
CH2	ON	OFF	ON	OFF
DHW	ON	OFF	OFF	ON

Note: the boiler is set up in this configuration out of the box

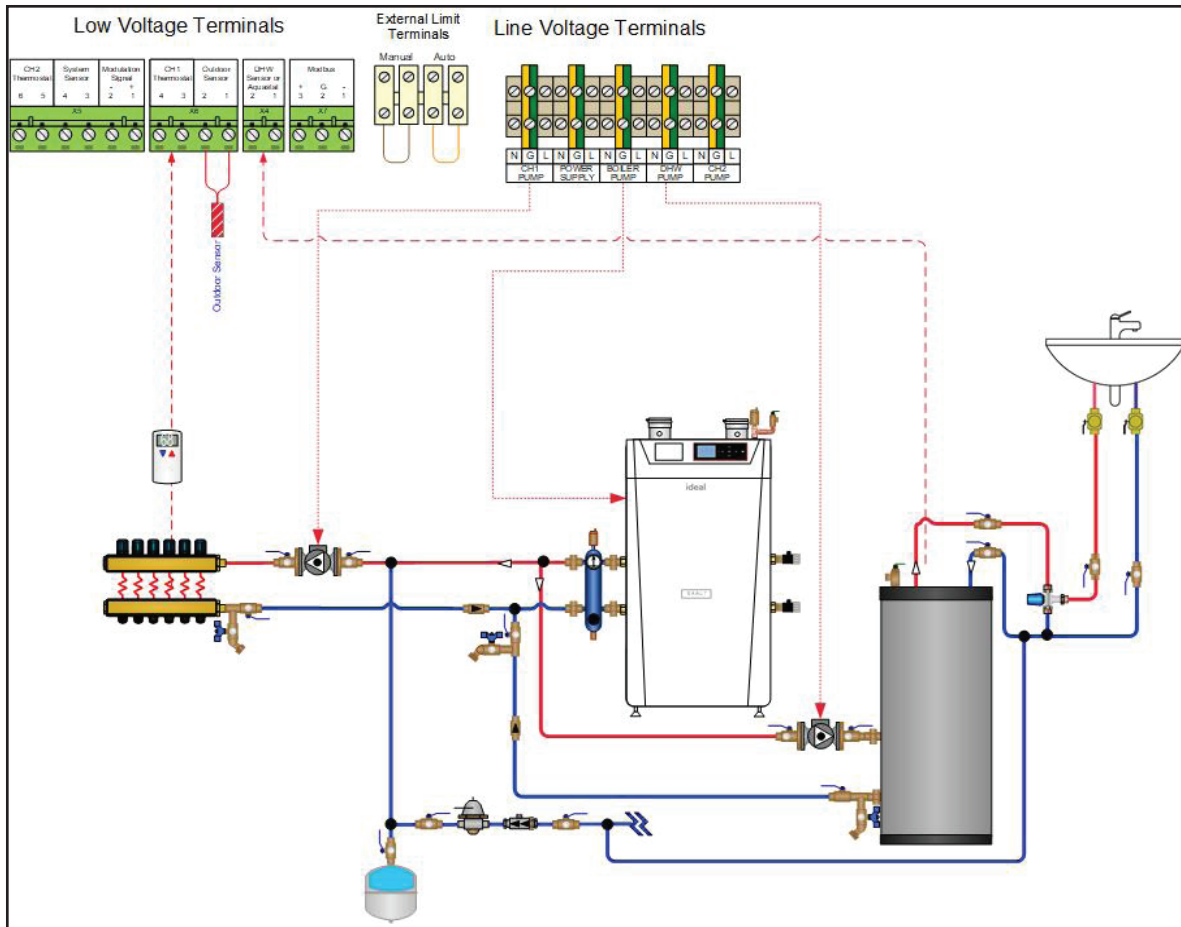

Fig. 22: Exalt Solo - Single Zone with Circulator

**NOTICE**

Piping layout is shown with a Hydraulic Separator.

Layout is shown with separate Circulator and check valve. If using a circulator with internal check valve, the corresponding check valve is unnecessary.

# Exalt Application Guide

### Preset A or D Pump Configuration (A shown)

Heat Call	Boiler Pump	CH1 Pump	CH2 Pump	DHW Pump
CH1	ON	ON	OFF	OFF
CH2	ON	ON	OFF	OFF
DHW	ON	OFF	OFF	ON

Note: the boiler pump settings must be changed for this arrangement

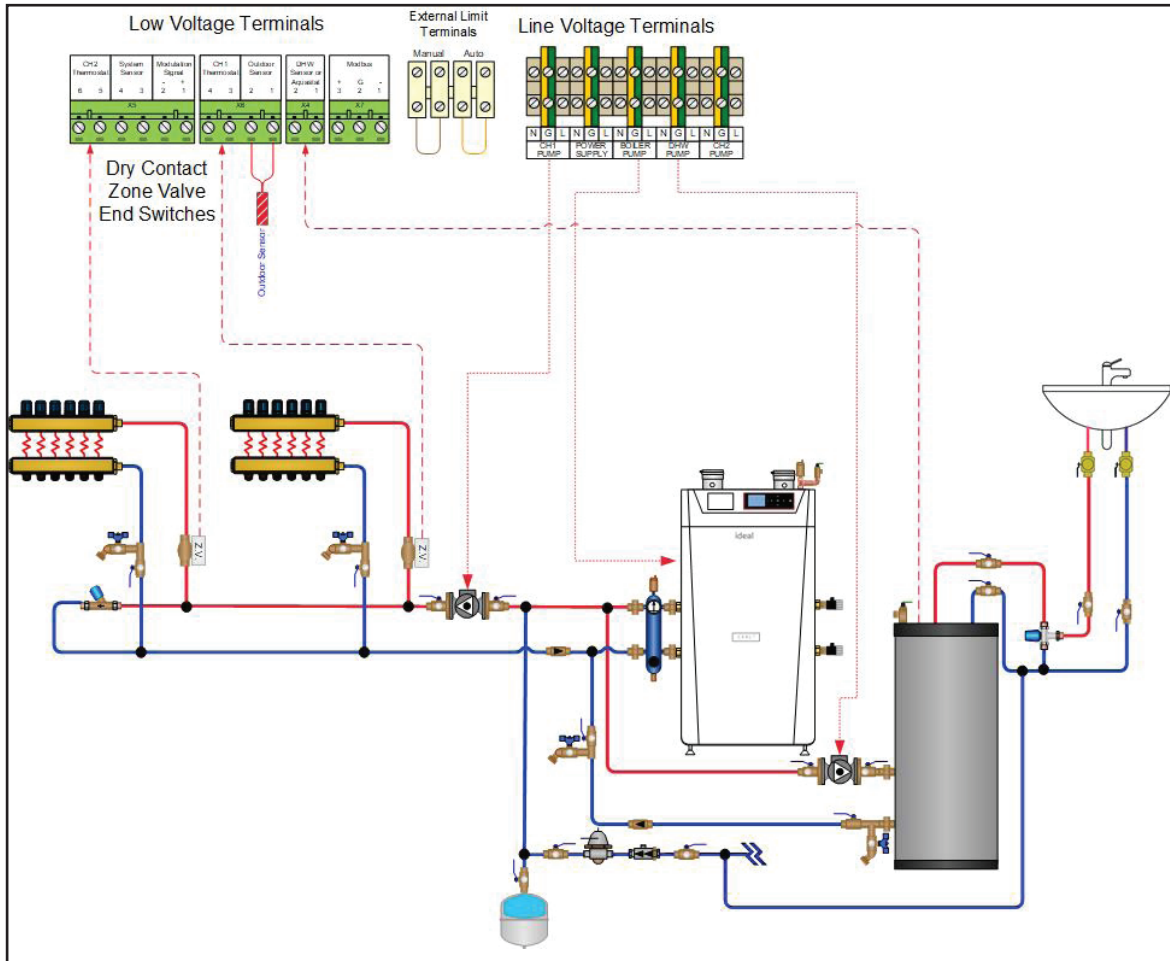

Fig. 23: Exalt Solo - Piping with Zone Valves

**NOTICE**

Piping layout is shown with a Hydraulic Separator.

# Exalt Application Guide

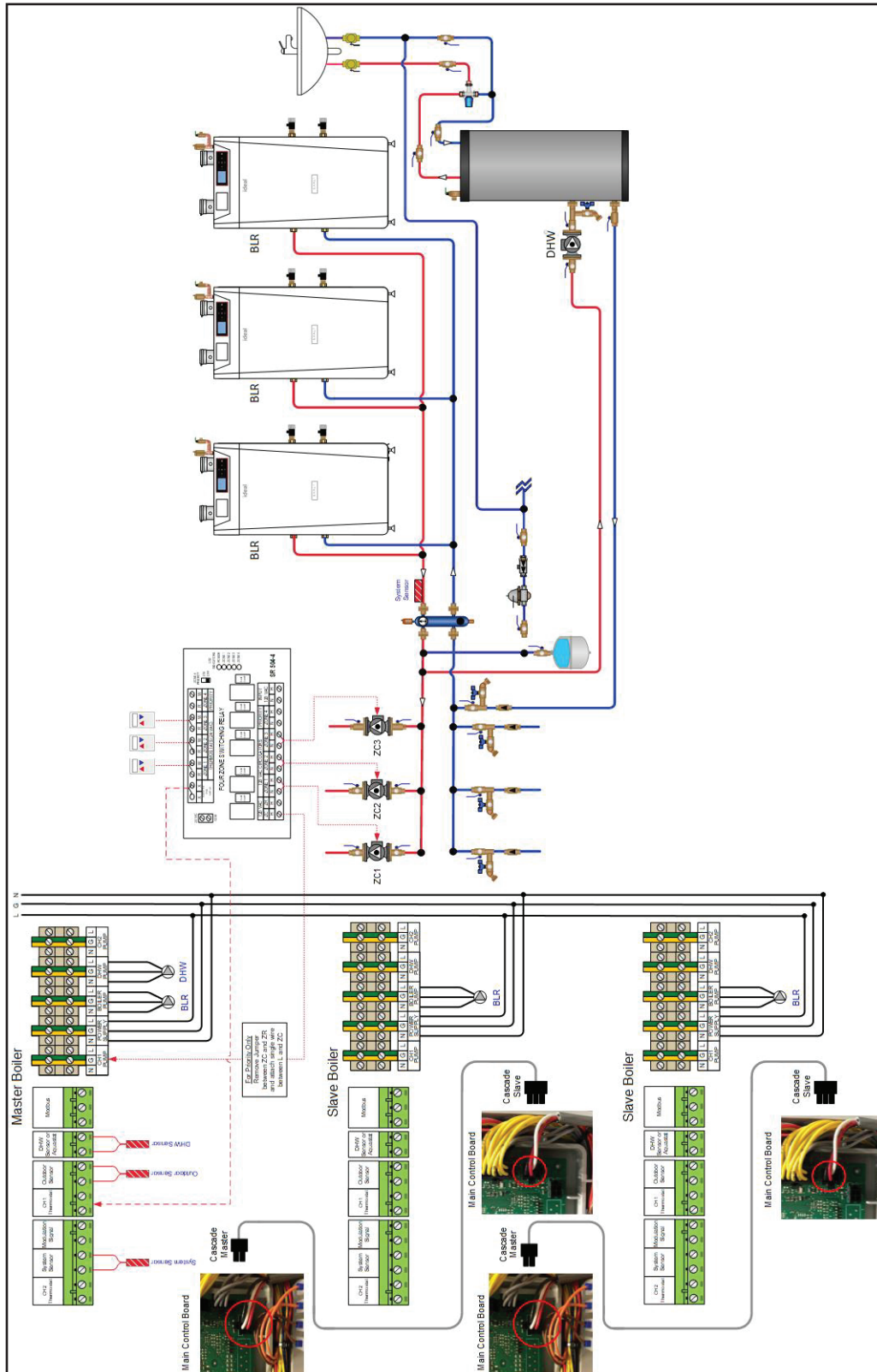

Fig. 24: Exalt Solo - Cascade Layout

# Exalt Application Guide

## 4. Exalt Combi Piping Diagrams

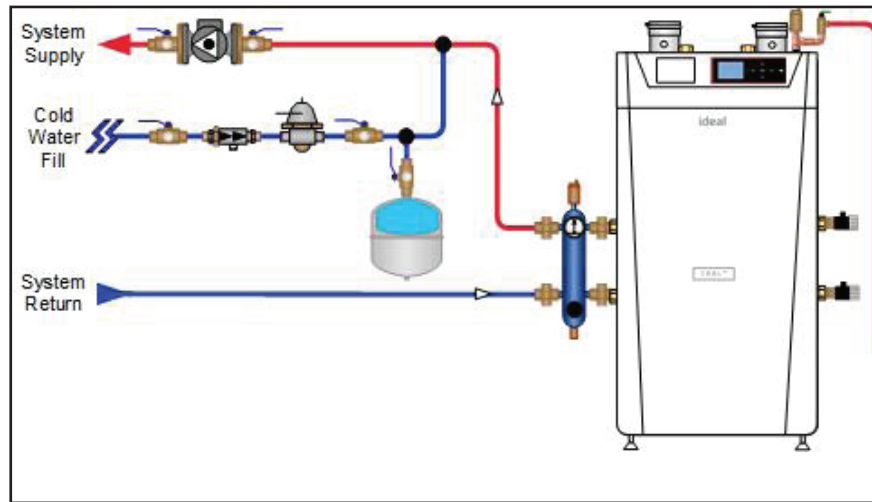

Fig. 25: Exalt Combi Near Boiler Piping with Hydraulic Separator

# Exalt Application Guide

## Preset B Pump Configuration

Heat Call	Boiler Pump	CH1 Pump	CH2 Pump	DHW Pump
CH1	ON	ON	OFF	OFF
CH2	ON	OFF	ON	OFF
DHW	ON	OFF	OFF	ON

Note: the boiler is set up in this configuration out of the box

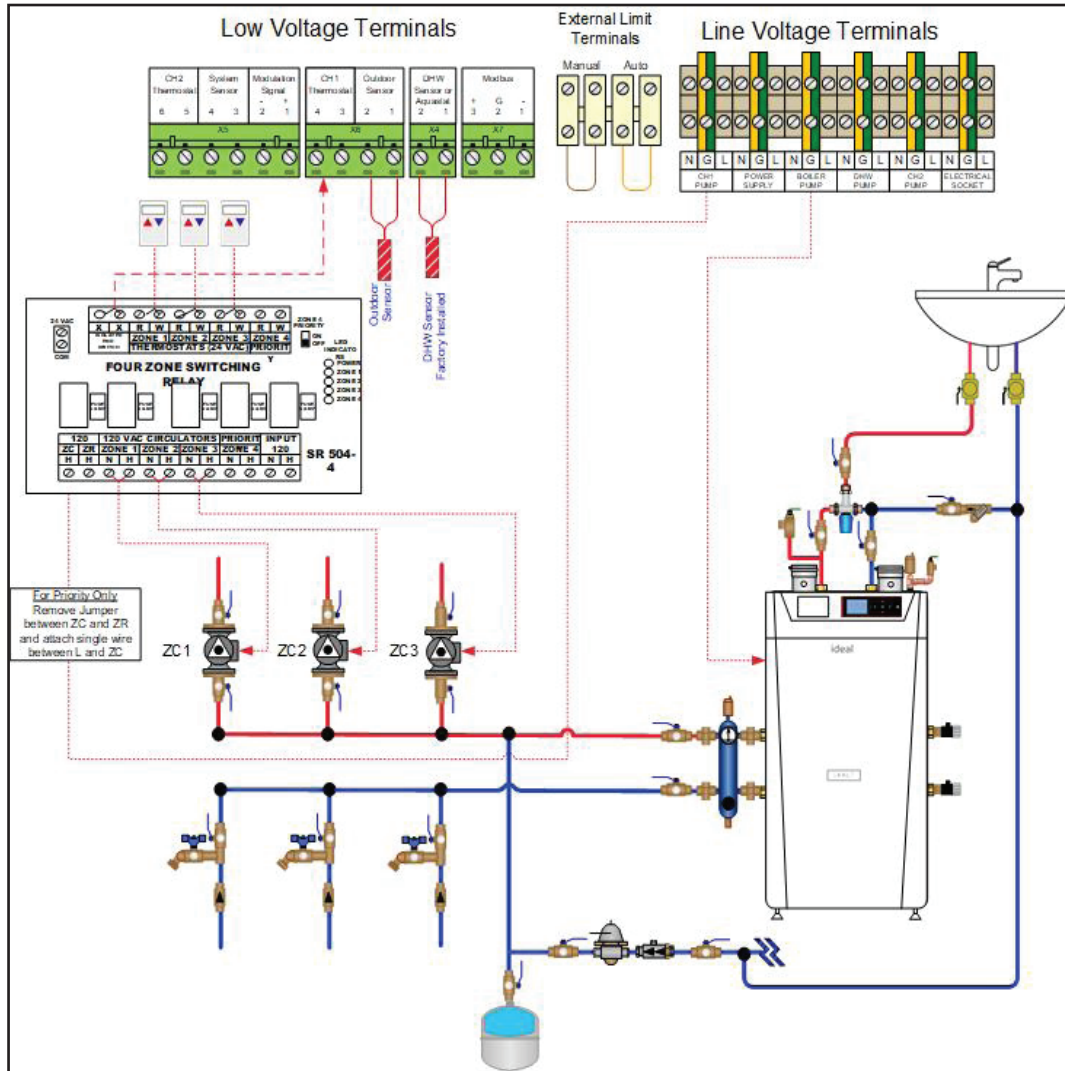

Fig. 26: Exalt Combi - Multiple Zones with Circulators

### NOTICE

Piping layout is shown with a Hydraulic Separator.

Layout is shown with separate Circulator and check valve. If using a circulator with internal check valve, the corresponding check valve is unnecessary.

# Exalt Application Guide

## Preset B Pump Configuration

Heat Call	Boiler Pump	CH1 Pump	CH2 Pump	DHW Pump
CH1	ON	ON	OFF	OFF
CH2	ON	OFF	ON	OFF
DHW	ON	OFF	OFF	ON

Note: the boiler is set up in this configuration out of the box

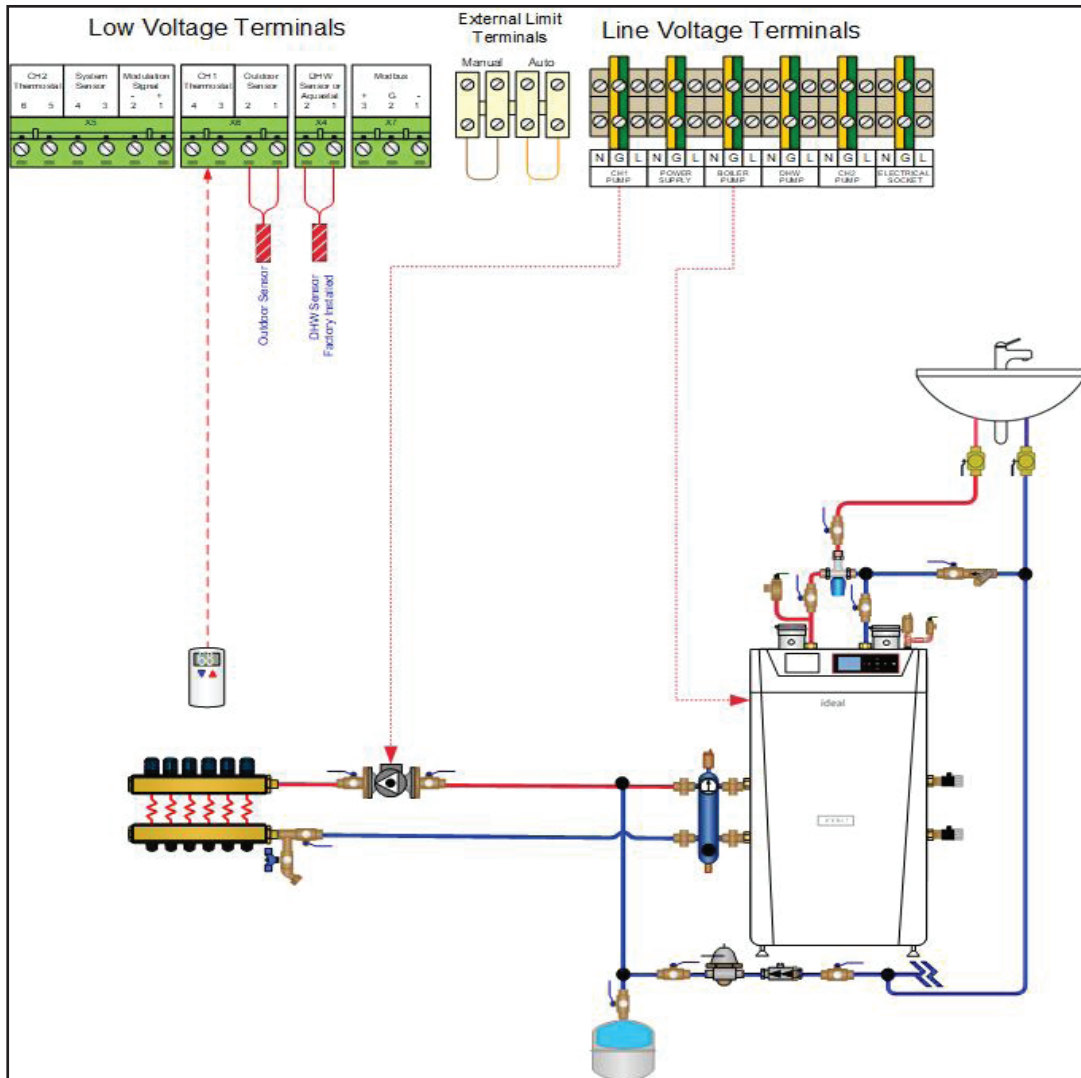

Fig. 27: Exalt Combi - Single Zones with Circulator

### NOTICE

Piping layout is shown with a Hydraulic Separator.

Layout is shown with separate Circulator and check valve. If using a circulator with internal check valve, the corresponding check valve is unnecessary.



# Exalt Application Guide

## Preset B Pump Configuration

Heat Call	Boiler Pump	CH1 Pump	CH2 Pump	DHW Pump
CH1	ON	ON	OFF	OFF
CH2	ON	OFF	ON	OFF
DHW	ON	OFF	OFF	ON

Note: the boiler is set up in this configuration out of the box

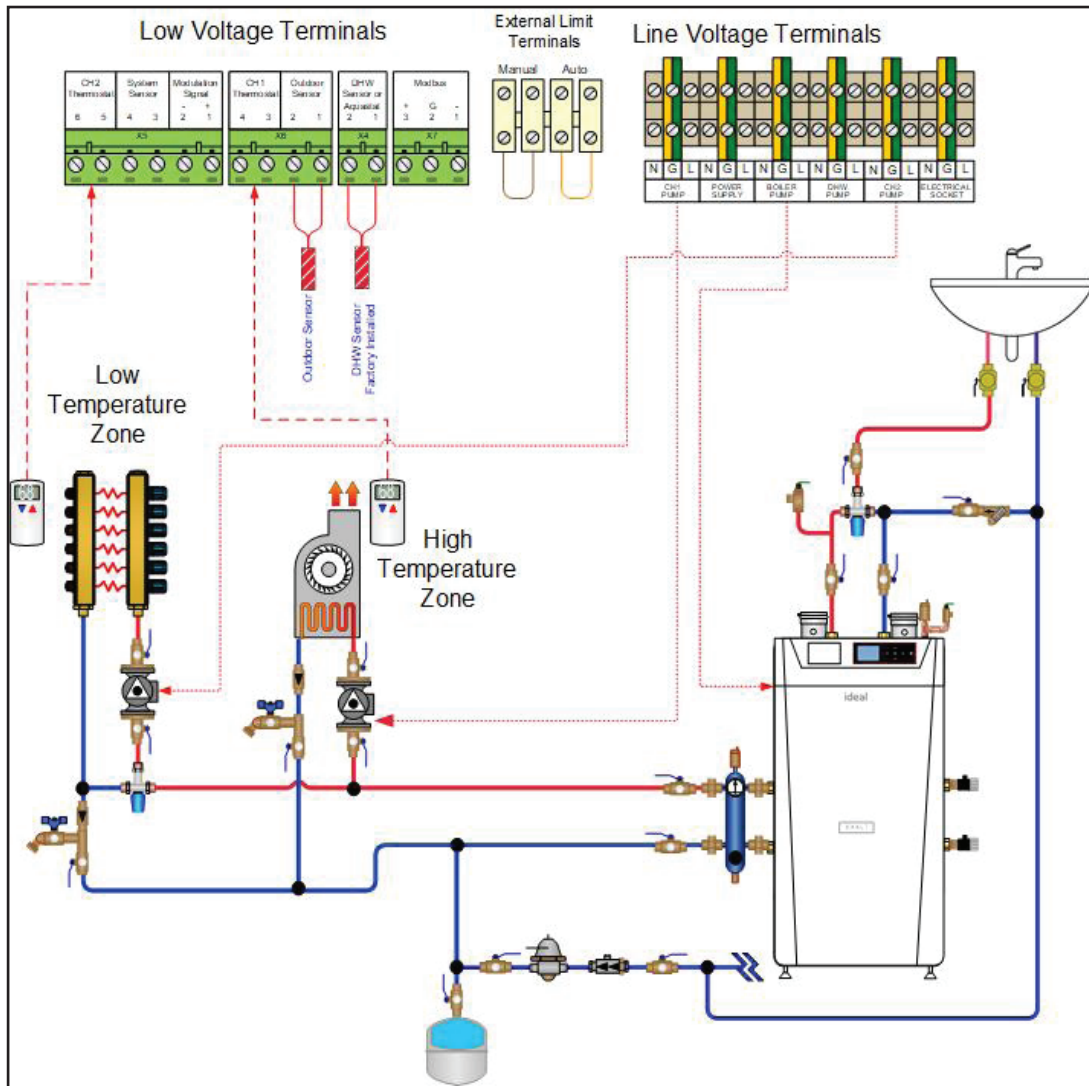

Fig. 28: Exalt Combi - Multiple Temperature Zones with Circulators

### NOTICE

Piping layout is shown with a Hydraulic Separator.

Layout is shown with separate Circulator and check valve. If using a circulator with internal check valve, the corresponding check valve is unnecessary.

# Exalt Application Guide

## Preset A or D Pump Configuration (A Shown)

Heat Call	Boiler Pump	CH1 Pump	CH2 Pump	DHW Pump
CH1	ON	ON	OFF	OFF
CH2	ON	ON	OFF	OFF
DHW	ON	OFF	OFF	ON

*Note: the boiler pump settings must be changed for this arrangement*

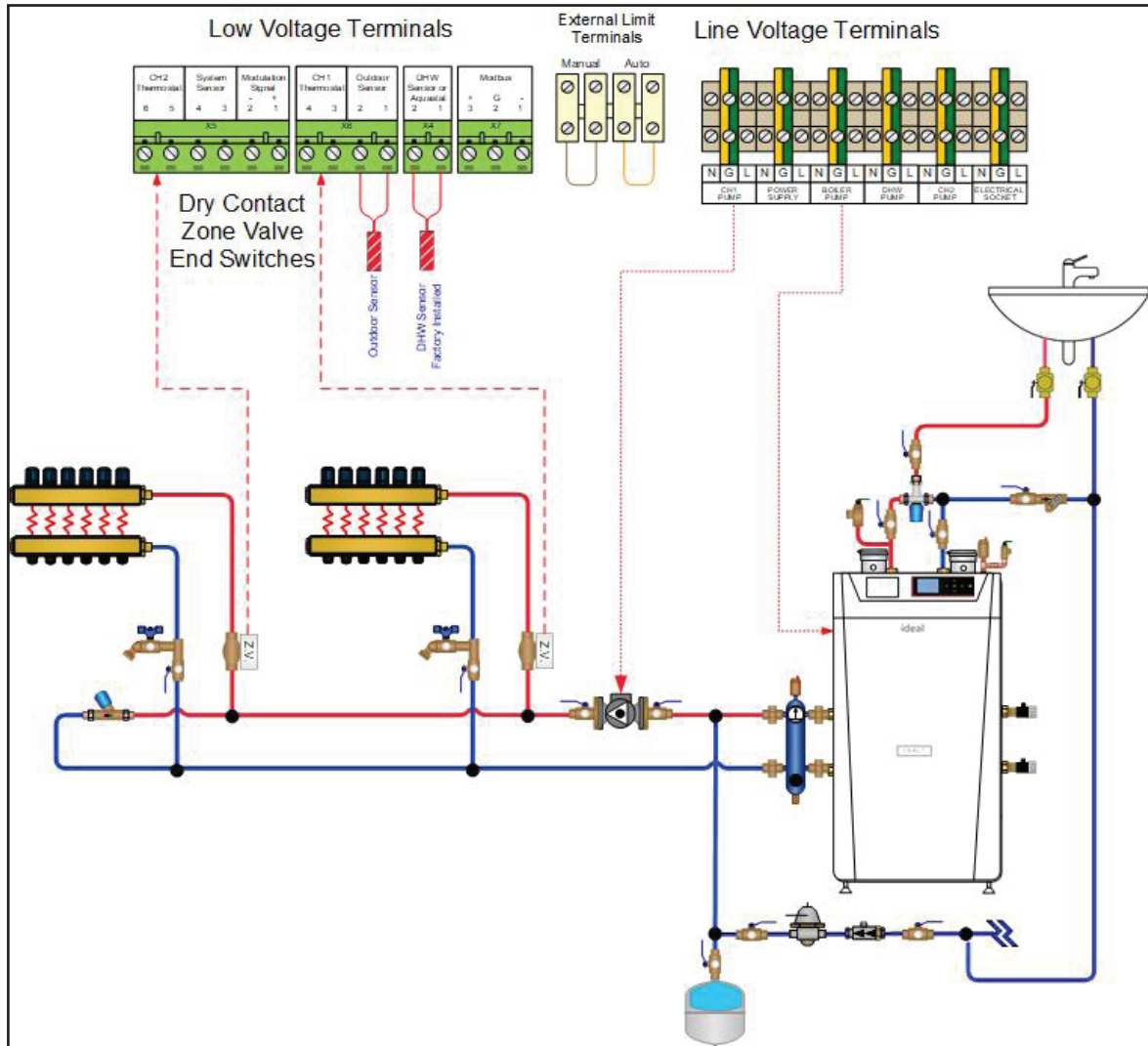

Fig. 29: Exalt Combi - Multiple Zones with Zone Valves

### NOTICE

Piping layout is shown with a Hydraulic Separator.

# Exalt Application Guide

## Preset B Pump Configuration

Heat Call	Boiler Pump	CH1 Pump	CH2 Pump	DHW Pump
CH1	ON	ON	OFF	OFF
CH2	ON	OFF	ON	OFF
DHW	ON	OFF	OFF	ON

Note: the boiler is set up in this configuration out of the box

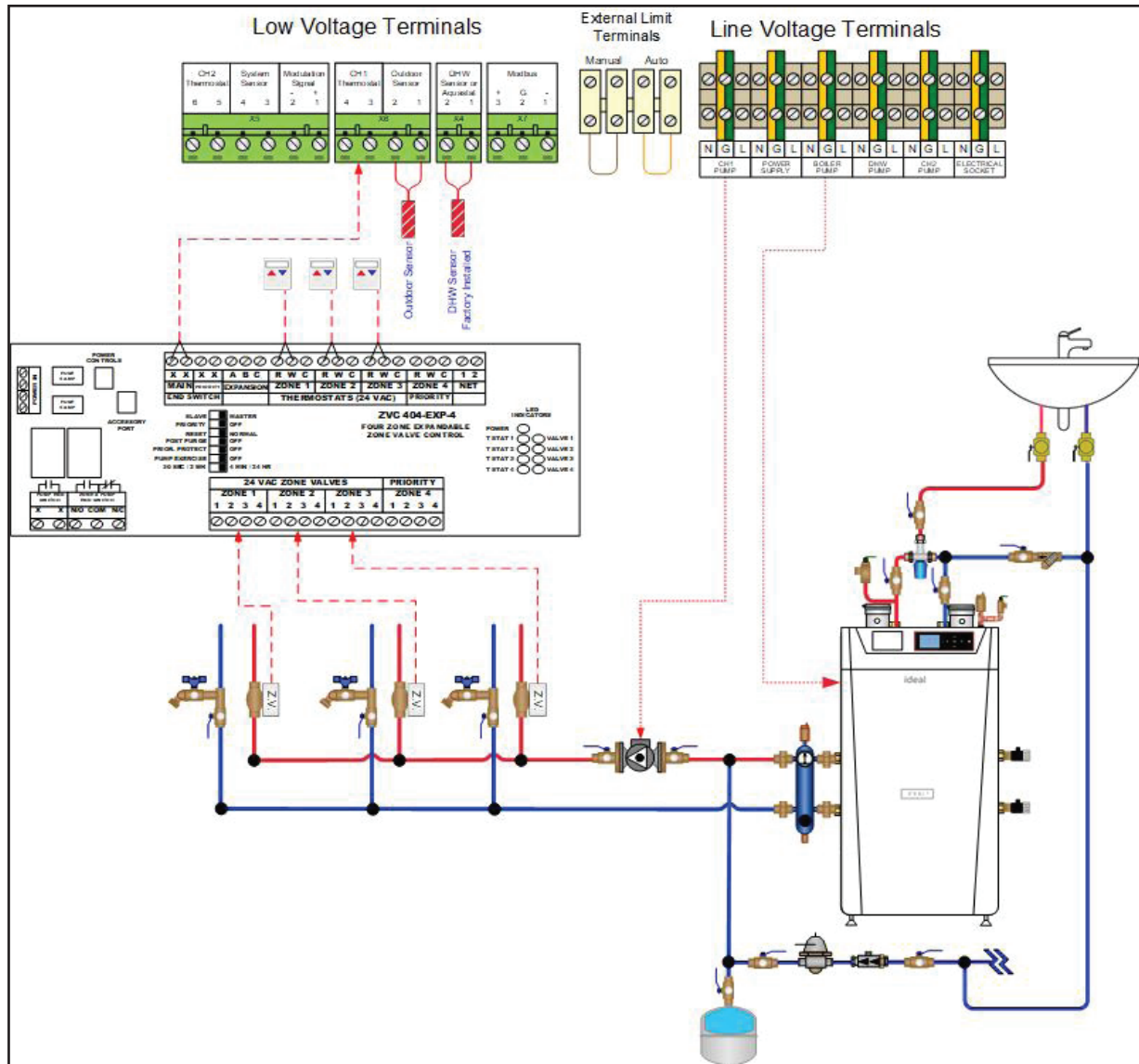

Fig. 30: Exalt Combi - Multiple Zones with Zone Valves and Zone Valve Control Panel

**NOTICE**

Piping layout is shown with a Hydraulic Separator.

