

# Challenger Fully Condensing Water Boiler and/or Water Heater



## Engineering Submittal CC 105



- Low water content
- Limited 10 year heat exchanger warranty
- 1 year parts warranty
- Light weight construction for wall mounting
- Standard equipment:
  - ASME 30 psi [2 bar] pressure relief valve
  - pressure and temperature gauge
  - high limit temperature safety control
  - domestic lead free mixing valve
  - outdoor temperature reset control
  - air vent
  - 120 volt terminal strip (power supply and boiler primary pump)
  - pressure sensor low water cut off
  - variable speed blower
- Stainless steel premix knit burner
- Reliable spark ignition
- Attractive appliance design for installation in high visibility areas
- Use of 80/125 mm concentric vent and air for single wall penetration
  - Total vent and air pipe length up to 60 equivalent feet each. (Each 90° elbow = 10 ft, each 45° elbow = 5 ft)
- Use of 3" PVC, CPVC or AL29-4C® (available April 2011) pipe for vent and air
  - Total concentric vent and air pipe length up to 60 equivalent feet each. (Each 90° elbow = 5 ft, each 45° elbow = 3 feet)
- Minimum vent length: 5 equivalent feet and vent terminal

### Engineering Submittal Data

- ASME Boiler Certification - ASME "H" Stamp
- Unit complies with ANSI Z21.13/CSA 4.9 Boiler and ANSI Z21.10.3/CSA 4.3 Water Heater Standards
- Fully condensing – 96% AFUE
- Microprocessor electronic gas and air modulation control
- Full modulation capability from 25% to rated input
- Modulation allows fewer and longer cycles leading to lower operating cost and longer component life
- Digital display control panel
- Electronic controls with easy to read menus, performance and trouble shooting codes
- Boiler water supply temperature can be maintained by the CHALLENGER, eliminating the need for a mix system to achieve the desired temperature with high limit protection
- Swing down control panel for easy access and service
- Control interface and logic for indirect fired hot water heater with priority
- Automatic boiler freeze protection
- Anti-freeze compatible per manufacturer's specifications
- Aluminum heat exchanger construction with vertical flueways with separate copper tube CH (Central Heating) and DHW (Domestic Hot Water) water ways

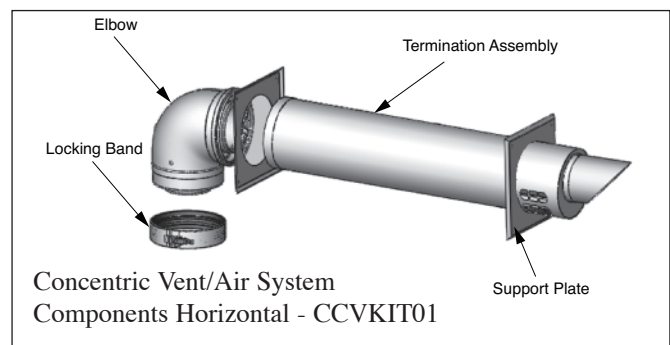

Project / Location: \_\_\_\_\_ Date: \_\_\_\_\_

Consulting Engineer / Architect: \_\_\_\_\_

Mechanical Contractor: \_\_\_\_\_

Notes: \_\_\_\_\_

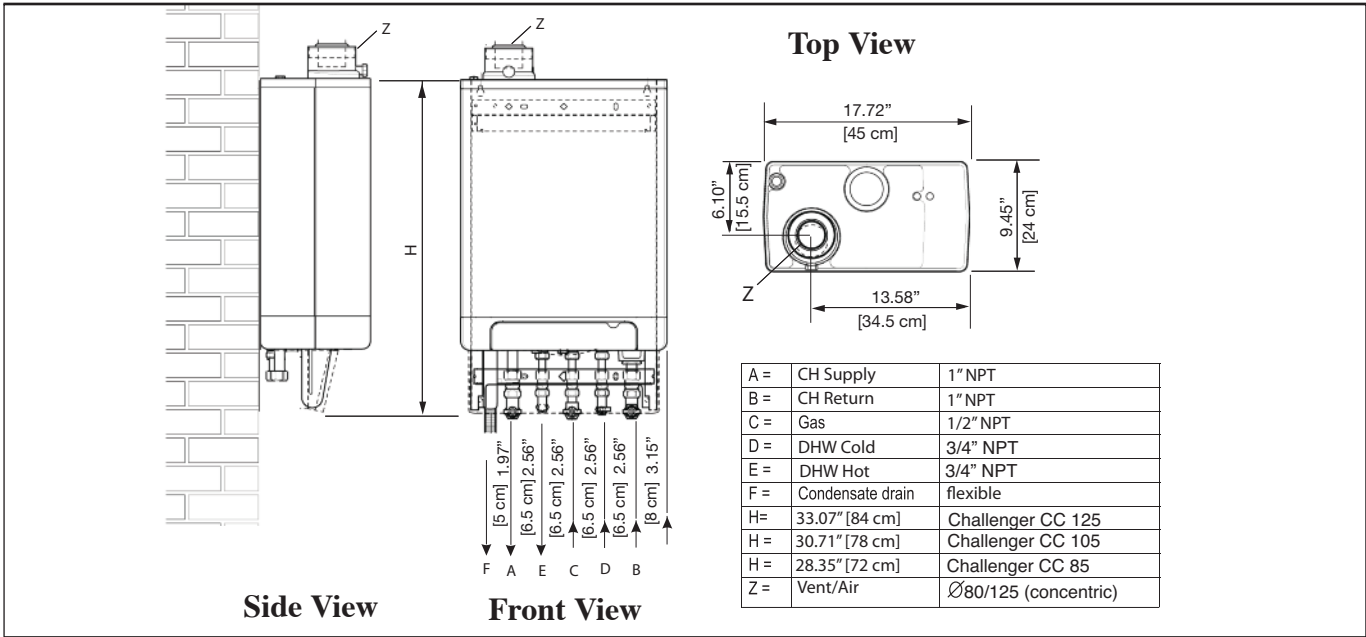

Model	Fuel	Input Modulation MBH [Kw]	AFUE	DOE Heating Capacity MBH [Kw]	Net I=B=R MBH [Kw]	CH Supply / Return Connections	Gas Connection	Air/Vent Diameter	Weight (Empty) [Kg]
CC 105	Natural or Propane Gas	29 to 106 [8.5 to 31]	96%	94 [27.8]	82 [24.3]	1"	1/2"	Concentric 80 mm Vent & 125 mm Air	73 [33]

### CH Pressure Drop Curve

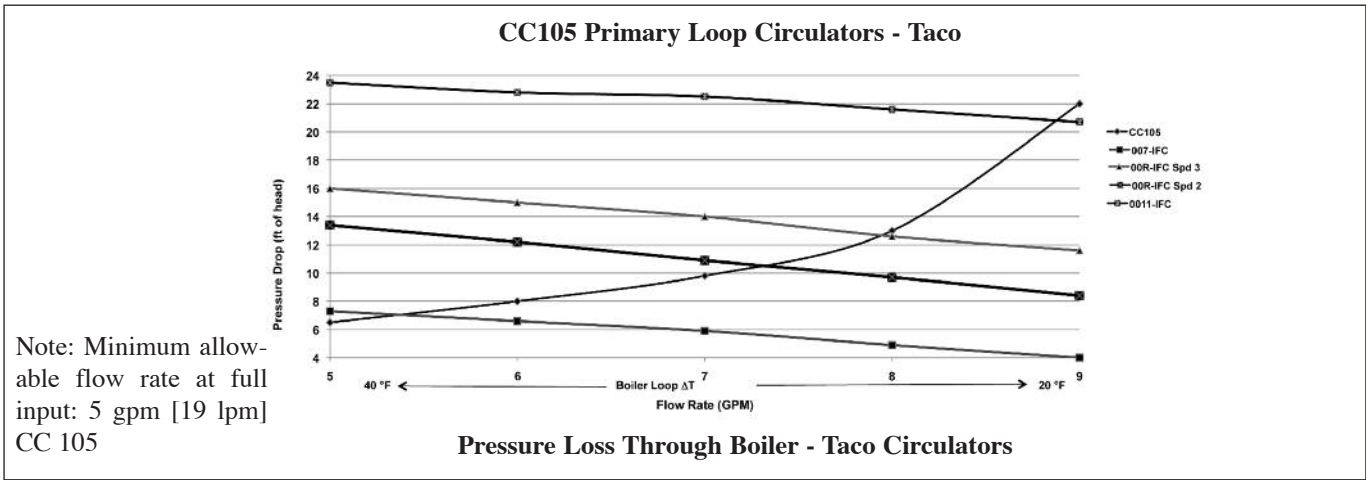
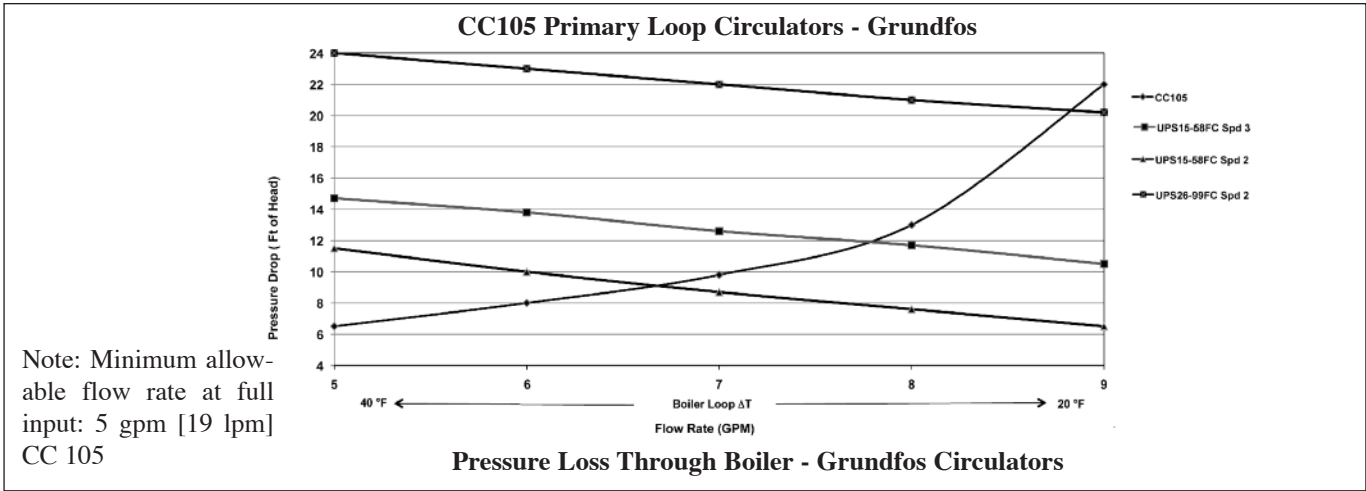

Model	Continuous Domestic Flow 70° F Rise	DHW Supply/Return Connections
CC 105	2.5 gpm [9.5 lpm]	3/4"

### DHW Performance Curve

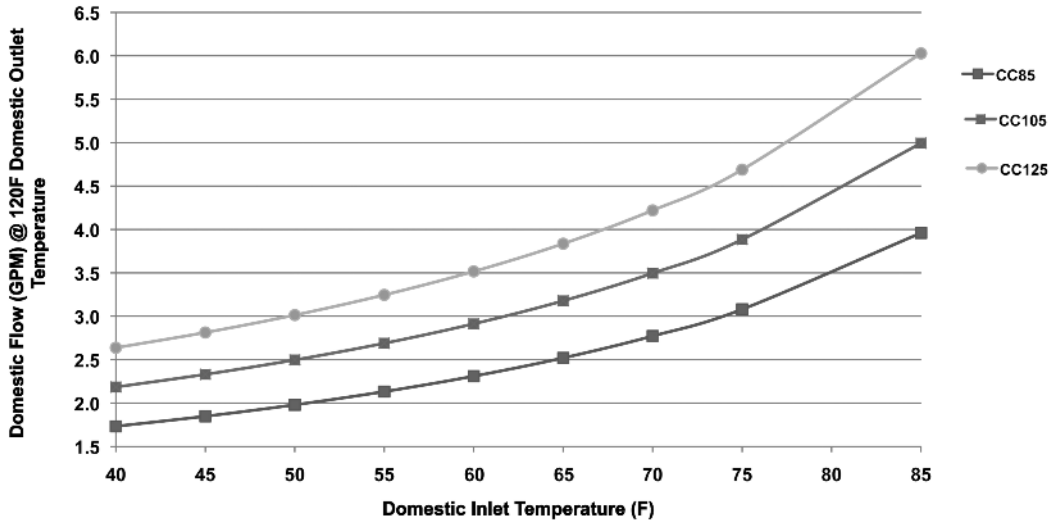

Domestic Flow Rate at 120°F Domestic Outlet and Varing Domestic Inlet Temperature

**NOTICE**

If actual flow rate exceeds the value listed in Graph the domestic outlet temperature will be reduced.

### DHW Pressure Drop Curve

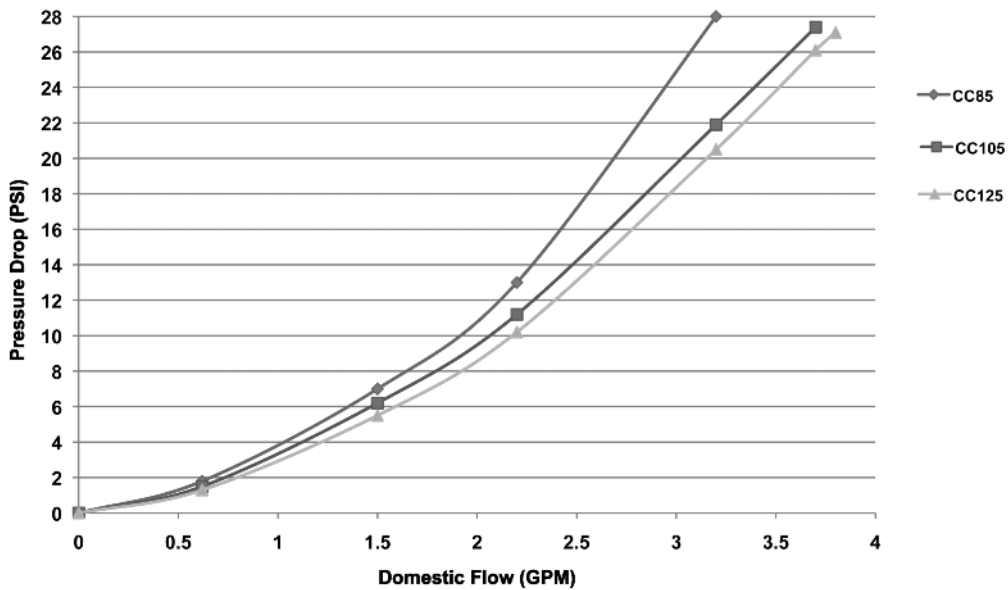

Pressure Loss Through Domestic