

HAMWORTHY
heating products

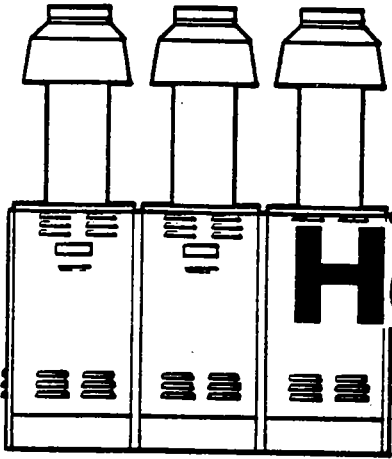

Hamworthy Heating Products

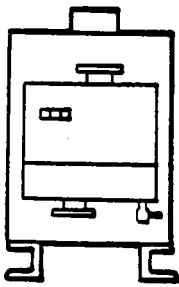

Tarrant Cascade and Guardian
Cold Water Booster Unit.

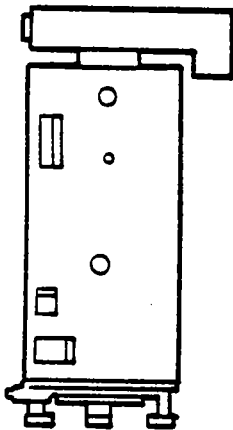

Installation, Commissioning and
Maintenance Manual.

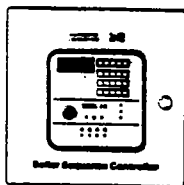

Document N° 50001021
Issue 'C'

(i)

INSTALLATION AND COMMISSIONING INSTRUCTIONS FOR THE FOLLOWING

TARRANT KASCADE BOOSTER UNIT

TARRANT GUARDIAN BOOSTER UNIT

FOR FIREGUARD (TF) MODELS ALSO REFER TO SUPPLEMENT 'A' 500001034

FOR MARINE (TD) MODELS ALSO REFER TO SUPPLEMENT 'B' 500001033

NOTE! THESE INSTRUCTIONS SHOULD BE READ AND UNDERSTOOD BEFORE ATTEMPTING
TO INSTALL, COMMISSION OR OPERATE THIS UNIT

IT IS IMPORTANT TO QUOTE SERIAL NUMBER WHEN ORDERING SPARES

DOCUMENT No. 500001021

ISSUE 'C'

(ii)

H A M W O R T H Y H E A T I N G P R O D U C T S

TARRANT BOOSTER UNITS FOR COLD WATER SUPPLY SYSTEMS

INSTALLATION, COMMISSIONING AND MAINTENANCE MANUAL

IMPORTANT

DO NOT REMOVE PAGES FROM THIS DOCUMENT

CONTENTS

<u>SECTION</u>	<u>DESCRIPTION</u>	<u>PAGE</u>
1.0	INTRODUCTION	1
2.0	TECHNICAL DATA	3
3.0	INSTALLATION AND STARTING INSTRUCTIONS	5
4.0	GENERAL OPERATION AND CONTROLS LOGIC	8
5.0	SITE COMMISSIONING AND TESTING	11
6.0	FAULT FINDING AND GENERAL SERVICING	13
7.0	PRINTED CIRCUIT BOARD FAULT FINDING	15

FIGURES (SEE RELEVANT SUPPLEMENT 'A' OR 'B' FOR FIREGUARD/MARINE)

No. 1	Technical Data
No. 2	Kascade Booster Capacity
No. 3	Guardian Booster Capacity
No. 4	Installation Details
No. 5	Typical Installation Notes
No. 6	Typical Installation Diagram
No. 7	Modular Kascade Booster Installation Instructions
No. 8	Typical Layout of Booster Internals
No. 9	Site Wiring Diagrams
No. 10	P.C.B. Layout
No. 11	Control Logic Pre-Set Figures
No. 12	List of P.C.B. Components/Functions
No. 13	General Fault Finding Data
No. 14	240 volt Control and B.E.M.S. Schematic Circuit
No. 15	Sensor Connections
No. 16	Kascade 415 volt Connections (D.O.L. Starting)
No. 17	Guardian 415 volt Connections (D.O.L. Starting)
No. 18	Kascade 415 volt Connections (Star/Delta Starting)
No. 19	Guardian 415 volt Connections (Star/Delta Starting)
No. 20	CEK/CK Pump Details
No. 21	HTS 25/32 Pump Details

FIREGUARD BOOSTER (SUPPLEMENT 'A') T.F. MODELS

Fig. 1	Technical Data
Fig. 3	Fireguard Booster Capacity
Fig. 9	Site Wiring Details
Fig. 14	Control Circuit
Fig. 17	3 Phase Circuit
Fig. 22	Typical Enclosure Layout
Fig. 23	Pressure Switch Details.

MARINE BOOSTER (SUPPLEMENT 'B') T.D. MODELS

Fig. 1	Technical Data
Fig. 3	Marine Booster Capacity
Fig. 8	Layout of Marine Booster Internals
Fig. 17	3 Phase Circuit
Fig. 20	NM Pump Details

INSTALLATION AND OPERATING INSTRUCTIONS

1.0 INTRODUCTION

The Hamworthy Tarrant range of Cold Water Boosters are designed to give optimum performance with various end user requirements. The range consists of several types of Booster each with their own advantages. (See Fig. No. 1). These are:-

i) TARRANT KASCADE (TK) (Fig. No. 2)

This type of control utilises sequencing of both pumps each of which can achieve 50% of simultaneous water demand (SD), thus giving 100% with both pumps running.

The Kascade control system is very efficient where intermittent use is required, ie. Hotel, Office, etc, which generally require flows of less than 50% for approximately 16-18 hours of the day with topping up taking place at peak demand times, ie. morning, midday and early evening.

ii) TARRANT GUARDIAN (TG)/FIREGUARD (TF) (Fig. No. 3)

This type of booster has the 'historical' 100% duty/standby control system. Only one pump is in use (during normal operation) which copes with 100% of simultaneous water demand (SD). If 100% back up is a pre-requisite, then this control option should be utilised. Generally used for roof top water storage filling from a low pressure main or can be adapted for hose reel fire fighting (BS 5306 Part 2).

iii) TARRANT MARINE (TD) (Fig. No. 3)

This is basically a TG (Guardian) booster, but has high quality bronze pumps suitable for pumping sea water/brine. Electrical details may vary due to shipboard use where voltages other than 415/3/50 Hz supplies are used.

Each Tarrant booster unit is pre-set at the factory to suit a standard application and should require no further site adjustments. The switching point of 1 to 2 pumps and vice versa of the Cascade control option is also pre-set and should require no further site commissioning.

If, however, individual applications require re-setting this can be accomplished by very small changes to the control logic sequence. See Section No. 5.0 (Commissioning and Testing).

All Tarrant variants shown in Fig. No. 1 are fully enclosed for ease of installation and offer very low noise levels in operation. They are designed to be able to go 'through' a standard industrial doorway (840 mm). Lifting eyes are provided with all units to assist with installation: see Fig. No. 4. See General installation details section 3.0 for further information.

The Tarrant Booster selected for an individual application is generally sized to give a simultaneous water demand at a specific head requirement. This demand will have been derived by utilising a sizing procedure typically as shown in BS 6700, 1987. This is based on past experience on the probability of usage of each individual tap outlet. It therefore follows that the booster may not be sized to give adequate flows with every appliance turned fully on.

2.0 TECHNICAL DATA

Reference to Fig. No. 8 shows the general layout of a Tarrant Booster Unit.

Pumps fitted to Cascade/Guardian and Fireguard models are manufactured in stainless steel throughout and are suitable for potable water if required: reference to Fig. No. 1 shows which model of pump is fitted to which Booster Unit. The pumps are end suction single or twin impellor type. This ensures minimal wasted energy by closely matching demand with power input. Reference to Fig. No. 1 shows the maximum closed head from each Hamworthy Booster Unit. When designing a system consideration should be given to components which have low pressure safety limitations.

Pumps fitted to the Marine booster have bronze body and impellers with 316 stainless steel shaft/seals etc. See supplement 'B' for further information.

On pumps larger than 3 kW a unique roller design permits both pumps to be withdrawn for servicing, etc.

Pipework within the Tarrant booster is modern solvent welded UPVC. This is resistant to noise carry over from the pumps and also minimises condensation within the unit. Suitable non-return valves are fitted to prevent back flow once the pump has been switched off. The inlet and outlet headers pass through the rear of the Booster, thus giving very flexible application in restricted/existing plant rooms. All 4 external flanges are 2 1/2" B.S. 4504 NP16 with 16 mm studs fitted. Maximum working pressure of the pipework is 6.2 bar g.

Every Tarrant booster is fitted with an internal 60 litre through design Accumulator. Cascade and Guardian models have a unique piping design feature which ensures no dead legs can occur within the accumulator or its pipework especially useful for preventing the growth of Legionellae bacteria within boosted water supplies. Isolating valves are fitted at each end of the accumulator thus permitting servicing to take place whilst the Booster is still in operation. The accumulator will be factory pre-set to suit the maximum pressure/flow pump curve condition. See Section 3 for settings.

Kascade, Guardian and Marine boosters have the same style of back-projected mimic display, giving local indication of control conditions.

These are:-

- i) Power on indication (red).
- ii) Pump(s) running indication (green).
- iii) Pump(s) tripped/fault indication (red).
- iv) Normal pressure indication (green).
- v) Low water level indication (red).
- vi) Pump No. 1 off/hand/auto switch.
- vii) Pump No. 2 off/hand/auto switch.
- viii) Pump/system re-set push button.
- ix) Pressure readout in bar g.
- x) A door interlocking isolator is also fitted.
- xi) When used in modular form a duty/slave switch is also incorporated.

These boosters also have the following volt free contacts for external/local indication:-

- i) Low water level.
- ii) Normal pressure.
- iii) No. 2 (R.H.) Pump trip/logic fault.
- iv) No. 1 (L.H.) Pump trip/logic fault.
- v) No. 2 (R.H.) Pump running.
- vi) No. 1 (L.H.) Pump running.

All the above are wired to the yellow coloured terminals on the terminal rail.

Also provided is a pair of contacts to give local audio/visual alarm of low water condition.

See Fig No. 9 for site wiring diagram. Note! maximum loading of these contacts is 2 amps (resistive) at 250 V.A.C.

The Cascade/Guardian and Marine ranges all incorporate a P.C.B. which contains the control logic. The miniature electronics used are of the robust C.M.O.S. logic system which are much more resistant to electro-magnetic interference.

The P.C.B. layout is shown in Fig No. 10. This Figure displays the board as seen with the fascia hinged down. Refer to section 4.0 and 7.0 for further information.

For Fireguard boosters refer to supplement 'A' for detailed technical data.

For Marine boosters refer to supplement 'B' for detailed technical data.

3.0 INSTALLATION AND STARTING INSTRUCTIONS

NOTE! ALL BOOSTERS MUST HAVE A SUITABLE EARTH.

If the unit is for domestic water use, all tanks, pipework and fittings must follow any local water authority regulations and should comply with the W.B.F.S. Regulations where applicable.

Tarrant Boosters are all factory tested and pre-set before despatch. The universal water header inlet/outlet connections are handed for right hand entry/exit. If the inlet is to be from the left, the temperature sensor will require moving from RIGHT TO LEFT position. Utilise the 1/4" BSP plug fitted to fill the right hand hole.

Note! All handings are when looking on the front of the unit. Sensor not fitted on Fireguard booster.

Whilst unpacking the unit, care should be taken to ensure external surfaces are not damaged. If possible remove the top and store in a safe place until the unit is fully running.

GENERAL (Refer to Fig. 5, 6 and 7 for Specific Installation Notes)

The Hamworthy Tarrant booster unit MUST be installed in accordance with the instructions given here and overleaf. Before installation commences it must be ensured that the unit(s) can be located with minimum clearance as shown on fig. 4. Location bolts must be firmly located and grouted in ensuring the base is level. If vibration mounts are to be fitted the locating feet are reversed to give sufficient clearance. Pipework must also be terminated with flexible connections when using vibration mounts.

The Tarrant booster set must be located in a position such that there is a flooded suction to the pumps at all times. The break tank (if fitted) must comply with relevant water authority regulations where required, especially if potable water installation.

* When installing the water storage tank, careful consideration must be given to provide sufficient static head to both pumps (see Fig. No. 8 for booster internal layout). To achieve this positive head the tank's water level should be at least 2/3 above the topmost pump inlet.

The Hamworthy Tarrant booster unit is normally supplied with inlet and outlet connections on the right hand side (viewing from front of unit). However, the inlet/outlet headers are supplied with blank flanges which can be changed to suit individual applications. All Tarrant Boosters are supplied with 2 1/2" BS 4504 N.P.16 flanges on inlet and outlet. See relevant note in fig. 5 with respect to positioning of valves/drains etc. Pipework must be supported local to the unit to avoid pipe strain on inlet/outlet headers.

All Tarrant booster units require a 5 wire 3 phase supply connection. Knockouts are provided for this and B.E.M. system connections. See fig. 4 and 9 for details. It is the installers responsibility to ensure adequate provision is made for the incoming power supply and that fuse/circuit breaker ratings are acceptable.

Note! Marine boosters may have supplies different from above due to shipboard use.

It is strongly recommended that the booster unit is installed with regard to B.S. 6700, 1987 (THE DESIGN, INSTALLATION, TESTING AND MAINTENANCE OF SERVICES SUPPLYING WATER FOR DOMESTIC USE WITHIN BUILDINGS AND THEIR CURTILAGES).

If the booster is to be coupled directly to an incoming water main (for which local water authority permission is required), care must be taken to ensure that the normal working pressure of the Booster unit is not exceeded, should the mains water pressure fluctuate.

STARTING PROCEDURE

Before opening booster isolating valves ensure that the accumulator charge pressure is as stated below:-

TABLE NO. 1 - ENSURE BOOSTER COMPLETELY DRAINED OF WATER PRESSURE

UNIT	TK10	TK12	TK14	TK16	TK18	TK20	TK22	TK24	TK26
ACCUMULATOR CUSHION PRESS BARG	1.1	2.0	3.0	4.0	4.8	2.3	3.0	3.8	4.8
UNIT	TG50	TG52 TF2 TD25	TG54 TF4 TD45	TG56 TF6 TD65	TG58	TG60	TG62	TG64	TG66
ACCUMULATOR CUSHION PRESS BARG	1.6	2.1	3.0	4.0	2.6	4.2	1.8	2.7	3.9

If the pressure is not as stated above adjust by the use of an oil free compressed air supply. The Schrader valve is situated beneath a black cap fitted to the accumulator.

Switch both pump off/hand/auto switches to 'off' position. Open inlet isolating valve, (ensure drain tap is off) and prime pump using air bleed screw or union on shut off valve. Ensure no leaks from pipework once both pumps are primed. Open outlet drain cock slightly, ensure outlet valve is fully closed.

Switch on mains isolator. Note! there are lethal voltages within the unit with the door removed and isolator in the 'on' position, great care must be exercised when working on the Booster unit. Hamworthy strongly recommend commissioning or servicing is only carried out by our engineers or a suitably qualified competent person.

Inch both motors by switching to hand momentarily. Both motors should run clockwise when viewed from the front, if not reverse incoming mains wiring (normally swap red and yellow phases), when rotation is correct switch both pumps to 'auto' position. All Tarrant booster units are pre-set at the factory and should require no site adjustments. After a short period both pumps should switch off and normal pressure should be illuminated. Close outlet drain cock and slowly open outlet valve until fully open.

If a low water level switch is fitted this interlock should be checked for correct function. Close incoming mains water supply to BREAK TANK. The booster unit will then start to empty the tank. When the float switch operates it should shut down both pumps. Restore mains supply which will permit both pumps to re-start. NOTE! IF NO WATER LEVEL SWITCH IS FITTED TERMINALS 2 AND 3 MUST BE LINKED. Failure to do so will cause low water circuit to be energised, and booster will not operate.

Ensure door is located correctly on to the base and mains isolator. Both pumps should now be left to operate in the auto-position.

Note! (MANUAL CONTROL SHOULD ONLY BE USED FOR TEST PURPOSES OR IN AN EMERGENCY.)

If a problem should occur consult section 6.0 Fault Finding and General Servicing or contact your nearest Hamworthy office.

4.0 GENERAL OPERATION AND CONTROLS LOGIC (FOR FIREGUARD SEE SUPPLEMENT 'A')

Two types of control system are used. These are:-

- i) Tarrant Cascade control:- two pumps each of 50% rating.
- ii) Tarrant Guardian/Marine control:- two pumps each capable of 100% rating.

All boosters utilise a door interlocking isolator for safety. The unit should only be operated with the door removed by a Hamworthy commissioning/service engineer or other competent person.

The pump motors are normally started direct on line (star/delta is optional on 5.5 kW and 7.5 kW motors). See Fig. No. 16, 17, 18 and 19.

Each pump motor is protected by a combined circuit breaker/overload device. The motor can be isolated from the control logic sequence by pressing the red button on the circuit breaker. This simulates an overload fault. The unit is then re-set by pressing the associated grey button on the circuit breaker.

The operation of each Booster is as below:-

- i) Tarrant Cascade:- with both pumps switched to auto position on the fascia the P.C.B. control logic will perform all the functions required to ensure correct operation of the unit. All Boosters are factory set to suit a standard operating cycle and should not normally require re-setting. During automatic operation the number of pumps in use at any one time depends on the flow requirements, the patented power/flow sensor logic responds to overall flow from the unit.

With the door interlocking isolator on and both pumps switched to auto, the following should occur:- each pump will start with a stagger of approximately 5 seconds to reduce incoming power surge. Both motors will then run for a short period. If demand is approximately 50% or less one pump will shut down. The remaining pump will then run providing there is a demand. Should the control logic sense minimal demand - approximately 1-2% of load, the pump will then shut down. Auto-rotation of duty pump is achieved at this point. The pressure transducer is now armed and will re-energise the control logic when the pressure drops below the set point.

Should a demand occur which exhausts the volume in the accumulator, the other pump will now start. If demand increases further beyond the 50% load condition the second pump will come into operation. Again once started it will run for a minimum of 3 minutes. 100% capacity can now be catered for. When the load reduces below 50%, the second pump will switch off leaving the first pump to run. Any further load changes will be catered for in this manner. Again when the load reduces to 1-2% the first pump will then switch off. This type of control logic where 'pressure' starts the Booster and 'flow logic' stops the last pump on dramatically reduces the stop/start sequence normally associated with pressure switch/transducer control.

Several Cascade booster units can be coupled together to the same water main in modular form. For this option the fascia will have a master/slave switch. When the 'master' unit's flow exceeds 100% the 'slaves(s)' will be switched in: on reduction of flow the 'slave' units are switched out first. See fig. 7 for installation details.

- ii) Tarrant Guardian:- here normally only one pump runs as it is capable of giving the full output required. However, this unit is also fitted with minimum flow control which will maintain constant running right down to 1-2% demand giving constant pressure conditions and almost entirely eliminating 3 minute cycling normally associated with booster systems.

All control systems also incorporate the following as standard:-

- i) Auto rotation of duty pump.
- ii) Instantaneous start of second pump should the first pump trip.
- iii) If the first pump fails to meet the minimum set point pressure due to, for example, a blockage at pump inlet the second pump will start at a pre-set reduction of set point pressure - normally 0.25 - 0.5 bar.

- iv) Should one or both pumps be inadvertently switched to manual mode, a thermal trip will shut the pump down in the event that a no flow condition exists for more than 30 minutes. This safeguards the pump bearings/mechanical seal assembly due to possible overheating and localised boiling. Note! The unit MUST NOT be left to run in manual mode without permanent supervision.

Note! If the overheat sensor is triggered by an unusually high pump temperature the pump fault indication will light up. The overheated pump will not re-start for approximately 1/2 hour. Pressing pump re-set button will have no effect until the pump casing cools down.

- v) The booster can still be run by utilising the manual motor circuit breakers should the printed circuit board fuse blow due to a component failure. Note! only recommended to provide essential back-up until unit can be serviced. The unit MUST NOT be left without supervision in this failure mode.
- vi) Low water/inlet pressure switch circuit which will instantly shut down one or both pumps to avoid running dry condition and consequent failure of the pump seal.
- vii) Remote indication of pump/logic fault if pump control is switched off manually and the pressure is below set point.
- viii) Master/slave control option which permits the Cascade Booster to be modularised. Therefore flows can be increased to suit any application with the power input closely matching the load requirements.
- ix) The digital display on the front can give various readings other than outlet pressure, eg. inlet water temp. load condition, and all set points in the logic system.

Note! Item vi) is a strongly recommended optional extra. The cost of the float switch is minimal compared to a pump(s) failure due to having been run dry. Low water can also be integrated with a B.E.M. system giving instant warning.

5.0 SITE COMMISSIONING AND TESTING

All Tarrant Boosters are factory set to suit standard parameters and should require no further adjustments for normal operation. See Fig. No. 1, 2 and 3 for expected duties.

Hamworthy strongly recommend the use of our trained service/commissioning engineers should other parameters be required to suit individual applications. See section 3.0 for general start up procedure.

If however adjustment is required the following parameters are available:-

- i) Normal pressure set point.* See note below.
- ii) Low flow sensor/temperature differential set point.
- iii) Unit overload or master/slave switch point.
- iv) Two pumps to one pump set point.
- v) One pump to two pumps set point.
- vi) Extra low pressure differential set point.

Refer to Fig. No. 10 for position of above set point adjusters.

Note! when re-setting the above, the variable resistors should be turned slowly until a response is achieved, the reading being allowed to stabilise before further adjustment.

In order to display these readings the following switch positions will require changing:-

- SW2 - to 'system' position
- SW4 - to 'com.' position
- SW5 - will then read off set points as indicated on multi-turn position switch.

Refer to Fig. No. 11 for normal settings.

Once adjustment has been carried out the switch SW2 should be left in the 'press.' position in order to display outlet pressure on fascia panel.

Refer to Fig. No. 12 for a comprehensive list of components on the printed circuit board.

The variable resistors RV7 - RV12 are factory set and should require no on site adjustment. These MUST NOT be tampered with by untrained personnel.

* Note! The normal pressure set point (RV1) adjusts the point at which the pump switches 'on' ie TK18 is set at 4.9 bar. The 'off' condition is dictated by the temperature differential set point (RV2) not the pressure transducer. Under normal operation, higher pressures will be achieved when little or no flow conditions are reached. See Figure No 1 for 'closed valve' pressures.

If it is considered that the closed valve pressure is too high a pressure reducing valve can be fitted to maintain a constant pressure.

NOTE! The above procedure must be achieved by removal of the front door and re-establishing power on to the unit. Great care must be exercised when working on the unit as lethal voltages are evident. Although most items are 'finger' safe, a short can occur when using uninsulated tools. Hamworthy strongly recommend the use of a competent person to carry out any servicing work on the booster.

Note! It is a requirement of the H.S.E. that only competent personnel carry out servicing work on this booster.

The fascia display should now read 15 - 17°C providing the relevant faulty sensor is selected on SW3. If this is correct the temperature sensor is faulty and should be replaced. If not correct then the connections to the P.C.B. should be checked. If all O.K. then the P.C.B. itself should be replaced.

NOTE! to achieve low hysteresis the temperature sensors directly interface with the water medium, they are NOT in isolating pockets. To replace any temperature sensor the unit will require isolating and draining before removal. A new olive will be required to achieve correct sealing of adaptor. Do not tighten Conex fittings more than necessary to achieve leak-proof joints. Note! If necessary boss blue sealing compound can be used on the olive to improve sealing.

6.5 kW Transducer (Kascade Unit only). This unit should be returned to Hamworthy for service or replacement. To check for correct function place digital volt meter across terminals A1 and A2 ref. Fig. No. 15. A voltage should be achieved between 1 - 5 volts which will relate to 'power ratio' display on fascia L.C.D. Note! display should read approximately zero with one pump running against a fully closed outlet valve. Note! the kW transducer handles lethal voltages and should not be tampered with until the power has been isolated.

6.6 Accumulator The charge pressure should be checked at least once a year. See section 3.0 for details. The external surface of the expansion vessel should be checked for signs of corrosion.

To replace the accumulator diaphragm:-

- i) Isolate accumulator at both ends.
- ii) Ensure vessel is drained of water.
- iii) Remove air from vessel by pressing centre of Schrader valve.
- iv) Disconnect accumulator at both Conex adaptors and remove assembly from Booster.
- v) Remove non-return valve from each end and inspect.
- vi) Unscrew centre brass 3/4" B.S.P. nut and remove
- vii) Remove bolts from flange at base of accumulator and remove diaphragm with care.
- viii) Check internal surface of accumulator.
- ix) Re-assembly is reverse to above.
- x) When sure all bolts and nuts are correctly tightened re-charge vessel. See section 3.0 for details.

6.7 Pipework. All pipework screwed threads are sealed with Loctite 225. This is the only type of Loctite suitable for use with U.P.V.C. tube. Boss blue and P.T.F.E. tape can also be used if required.

7.0 PRINTED CIRCUIT BOARD FAULT FINDING

All Tarrant Boosters are tested and commissioned before leaving the factory. However, if a problem is suspected with the control logic the following should be checked:-

7.1 Printed Circuit Board Fuse. Reference Fig. No. 10. This a 500 mA cartridge type housed near the mains supply head to the P.C.B. Note! 110 V.A.C. control systems will have a 1 amp fuse.

7.2 To establish correct positioning of switches for each particular booster refer to the following:-

7.2 1) Tarrant Cascade (single unit):-

Master/slave switch SW9 must be in the master position.
Kascade/Guardian switch SW7 must be in the (inc. L/Dec.L) position (both).

7.2 2) Tarrant Guardian (single unit):-

Master/slave switch SW9 must be in the master position.
Kascade/Guardian switch SW7 must be in the ext. position (both).

For pressure display on fascia ensure SW2 system pressure switch is in press. position.

7.3 To establish correct board logic function the following test point (TP) voltages should be achieved:-

- TP2:- - 15 volts D.C.
- TP3:- Approximately 22 - 31 volts D.C.
- TP4:- + 15 volts D.C.
- TP5:- Low pressure 13 - 15 volts D.C.
Not low pressure < 1 volt D.C.
- TP6:- Temperature differential tripped 13 - 15 volts D.C.
Not tripped < 1 volt D.C.
- TP7:- Load increasing 1 pump - 2 pumps 13 - 15 volts D.C.
Not tripped < 1 volt D.C.
- TP8:- Load decreasing 2 pumps - 1 pump 13 - 15 volts D.C.
Not tripped < 1 volt D.C.
- TP9:- Pressure normal 13 - 15 volts D.C.
Not normal. < 1 volt D.C.
- TP10:- Overload triggered 13 - 15 volts D.C.
Not triggered < 1 volt D.C.

All the above are with respect to TP1 = 0 volt rail.

- 7.4 The P.C.B. assembly complete with fascia mimic can be removed if required by carefully unplugging the orange plugs and withdrawing the two hinge screws. Care must be taken to avoid damage to the board when carrying out this exercise. Retain plastic hinge bushes and screws/washers, etc.

It is strongly recommended that any service/replacement work be undertaken by sending the whole assembly to Hamworthy Heating for analysis.

In the event that a new board is required. the variable resistors RV7 - RV12 will require re-setting to match the sensors fitted.

Note! If a P.C. board is changed on site, the following procedure must be carried out in the order shown below:-

- i) Shut inlet and outlet booster isolating valves and open drain cocks to remove any pressure from inside booster pipework.
Switch 'SW2' to 'System'.
Switch 'SW3' to 'System Pressure'.
Set RV9 to read zero (approximately) on digital display.
- ii) Open booster inlet valve. Shut drain valve. Ensure both pumps are primed.
- iii) Switch No 1 pump to 'Hand'. Check 'SW3' on PCB is set to 'System Pressure'. See Figure No. 1 for particular models 'Closed Valve Pressure' and adjust RV8 accordingly. For example:-

A TG 56 closed valve = 61 metres. Divide by 10.2 to find pressure in bar. Therefore $61 \div 10.2 = 5.98$ bar.
RV8 can now be adjusted to read 5.98 bar.

Switch off pump and check for soundness of isolating valve. Pressure should not vary significantly.

- iv) If a Cascade model PCB is changed, the kW meter will need setting up. This can be achieved as follows:-

Close booster outlet valve.

Switch Pump No 1 to 'Hand'.

Switch 'SW3' to 'kW Load' position.

Set RV11 to read approximately zero on display.

Note! Due to normal tolerances some boosters will only achieve 3 or 4% on display; this will have no significant effect on the normal operation.

Switch Pump No 2 to Hand (both pumps should now be running).

Open booster outlet valve slowly.

Switch 'SW3' to 'System Press.'.

Open outlet valve fully and open taps or drain cock until digital display shows pressure as per Figure No. 1.

ie a TK 18 head at maximum flow rate will give 51 metres head, which, divided by 10.2 gives 5 bar. Therefore, outlet valves should be opened until 5 bar is showing on display.

Switch 'SW3' to 'kW Load' position and wait for reading to stabilise.

Set RV12 to read 100% at this flow rate.

Switch 'SW3' back to 'System Press.' to ensure pressure is as calculated previously and has not changed.

The above procedure permits a P.C.B. change to be effectively carried out on site without sophisticated measuring equipment.

However, if it is thought the booster is not operating correctly after carrying out the above the P.C.B. will have to be returned to Hamworthy Heating for a more detailed investigation.



HAMWORTHY
heating products

Fig N°1

DATA SHEET N°04:21:07

DATE 3/4/91

ISSUE 'C'

SUBJECT: Tarrant Booster Technical Data.

Full load curves same curves + 6 on 7

Tarrant 'KASCADE' Booster Data. (Models with LOWARA pumps only)

MODEL CODE	PRODUCT CODE	MAXIMUM kW LOAD	MAXIMUM AMPS	PUMP TYPE	CLOSED VALVE hd.	MAX.FLOW litres/min	HEAD AT MAX.FLOW	OVERALL W'T. kg
TK 10	563217001	2.2	6	CEA 210/3	22 m.	440	13 m.	215
TK 12	563217002	3.7	9	CEA 210/5	30 m.	440	22 m.	225
TK 14	563217003	3.7	8.6	CA 200/33	43 m.	300	32 m.	225
TK 16	563217004	4.4	11	CA 200/35	52 m.	300	42 m.	230
TK 18	563217005	6	13.2	CA 200/55	61 m.	300	51 m.	230
TK 20	563217006	4.4	9.2	HTS 25/160/22	36 m.	500	25 m.	240
TK 22	563217007	6	12.8	HTS 25/160/30	42 m.	500	32 m.	245
TK 24	563217008	8	15.8	HTS 25/200/40	53 m.	500	40 m.	245
TK26	563217009	11	22	HTS 25/200/55	62 m.	500	50 m.	290

Tarrant 'GUARDIAN' Booster Data. (Models with LOWARA pumps only)

MODEL CODE	PRODUCT CODE	MAXIMUM kW LOAD	MAXIMUM AMPS	PUMP TYPE	CLOSED VALVE hd	MAX.FLOW litres/min.	HEAD AT MAX.FLOW	OVERALL W'T. kg
TG 50	563217011	1.5 *	2.1 *	CEA 210/4	26 m.	220	18 m.	215
TG 52	563217012	1.85 *	4.3 *	CA 200/33	43 m.	220	23 m.	225
TG 54	563217013	2.2 *	5.5 *	CA 200/35	52 m.	220	32 m.	225
TG 56	563217014	3 *	6.6 *	CA 200/55	61 m.	220	42 m.	230
TG 58	563217016	3 *	6.4 *	HTS 25/160/30	42 m.	325	28 m.	245
TG 60	563217018	5.5 *	11 *	HTS 25/200/55	62 m.	325	44 m.	290
TG 62	563217019	4 *	7.9 *	HTS32/160/40	37 m.	475	20 m.	260
TG 64	563217020	5.5 *	11 *	HTS32/200/55	48 m.	500	29 m.	290
TG 66	563217021	7.5 *	14.6 *	HTS32/200/75	60 m.	500	41 m.	300

*: Under normal operation. - For pipe sizing multiply by 2



HAMWORTHY
heating products

Fig No 3

DATA SHEET N°04:21:32

DATE 26/8/92

ISSUE 'B'

SUBJECT:- Tarrant Guardian Booster Unit

Performance Of Tarrant Guardian Cold Water Booster Set

Note! Fluid Medium - Fresh Water at 20°C
Static Head at Inlet = 2 metres

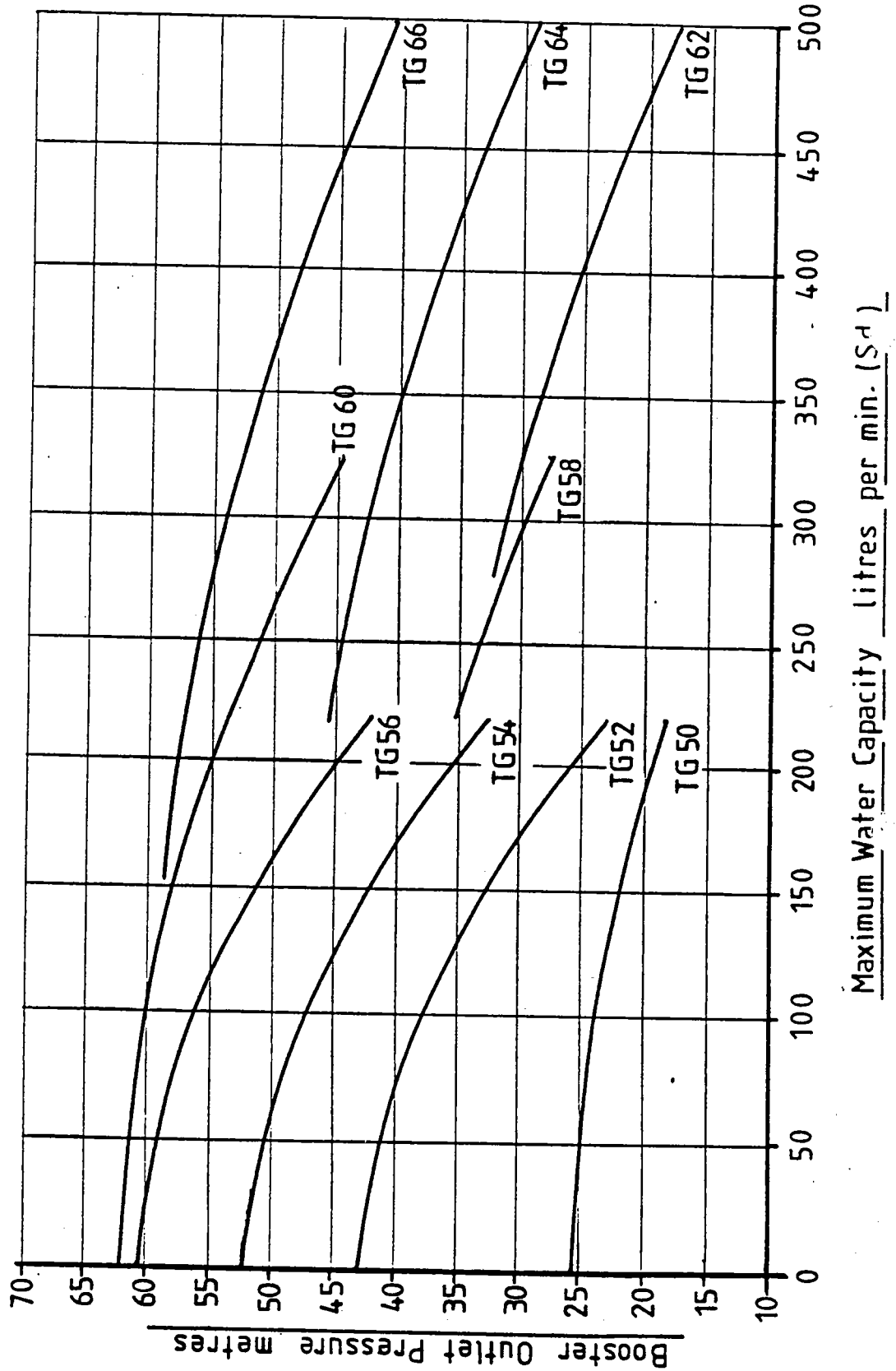



HAMWORTHY

heating products

Fig No 4

DATA SHEET No 04:21:23

DATE 14/5/91

ISSUE 'A'

SUBJECT: Tarrant Booster Installation Details

NOTES:

FLOW AND SUCTION CONNECTIONS ARE ACHIEVED VIA STUDED BACKING FLANGES LOCATED ON THE ENDS OF THE PIPEWORK WHICH TRAVERSES THE UNIT — FLOW ON THE TOP AND SUCTION BENEATH AS SHOWN. BLANK FLANGES ARE SUPPLIED TO CAP THE NON-UTILISED ENDS AS APPROPRIATE. BOTH FLOW AND SUCTION CONNECTION FLANGES ARE 2 1/2" n.b. TO B.S. 4504. RATED AT NP10/16 — STUD SIZES (4 OFF EACH CONNECTION) BEING M16.

ALL CONNECTIONS ARE AVAILABLE FROM BOTH SIDES OF THE UNIT.

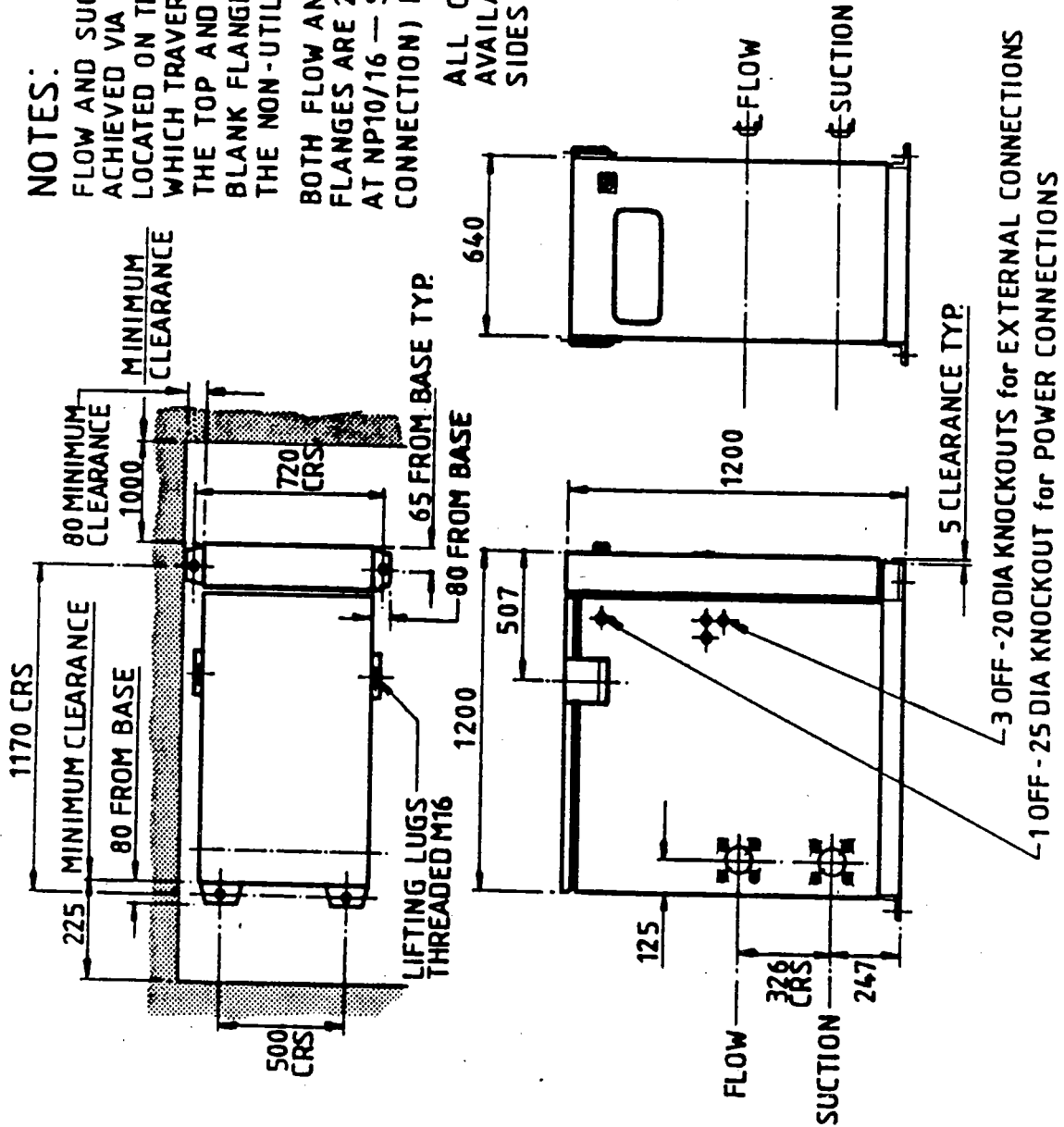



HAMWORTHY
heating products

Fig No 5

DATA SHEET No -

DATE 3 / 4 / 91

ISSUE A

SUBJECT:- Tarrant Booster Installation Notes

Note No. 1

Suction/discharge connections. All Tarrant Booster units are supplied with 2 1/2" BS 4504 N.P. 16 flanges. If the pipework to the Booster is not at above eccentric reducing pieces must be used keeping the top of the pipework in line. This will prevent air from becoming trapped in the pipework possibly leading to dry running of the mechanical seal inside the pump. The pipework must be adequately supported local to the Booster Unit.

If the Booster is to be mounted on anti-vibration mounts the inlet/outlet pipework must also have flexible connections. Hamworthy Heating supply a complete package as an optional extra.

Note No. 2

Isolating valves must be installed on both the inlet and outlet connections. These valves and fittings should comply with water bylaws, especially for potable applications. Suitable drain cocks should be installed between the isolating valve and Booster unit (see drawing). These should be to B.S. 2879 - 2 1980. Typically conex type 5742/TA or equivalent. These valves are essential for commissioning and servicing and should not be omitted.

Note No. 3

The Booster unit will require a suitably fused 3 phase, 415 V, 50 Hz power supply. This should include a neutral and earth connection. All wiring must be adequate in size to carry the maximum current of both motors. Note! The Guardian Booster could have both motors operating together.

It is the responsibility of the installing engineer to ensure that all wiring complies with local regulations and that is in accordance with relevant I.E.E. wiring regulations.

Cable gland knockouts are provided on each side panel. 25 mm dia incoming mains supply, 20 mm dia for B.E.M. system and break tank low water connections.

Note No. 4

The break tank low water switch is optional (although strongly recommended) and if not fitted terminals 2 & 3 (grey colour) should be linked on the control unit terminal rail. The switch should be installed at a suitable position to ensure no air can be drawn into the booster pipework at or approaching low water condition. The contacts must be wired normally open to ensure fail safe operation should the float become detached.

If the unit is fed direct from a water main, the use of a low pressure switch to detect suction within the main is strongly recommended. This should be wired in place of the low water float switch.

Note No. 5

The water break tank should be positioned such that a positive flooded suction is available to the Booster even at a low water condition. The incoming supply should not be located local to the outlet to the Booster as air can be carried through by the pressure action at the ballcock discharge. The ballcock should comply with BS 1212 Part 2 and be adequately sized to ensure water level is maintained throughout the day. If potable water is stored then all fittings must comply with W.F.B. scheme and the tank should be of an acceptable design. No chemicals should be added to this tank. Consult local water authority concerning whether a type 'A' or 'B' air gap is required.

Note No. 6

The 60 litre accumulator fitted as standard is factory set for correct matching to the Booster duty. However, this can be checked by using a car type pressure gauge (maximum of 8 bars), compare with installation instructions for correct pressure. If more volume accumulation is required an expansion vessel can be connected to the spare outlet connection. A new flange will be required as the standard unit is of mild steel with a stainless steel backing disc to ensure water potability. This vessel's cushion pressure must be set to match the internal accumulator.

Note No. 7

Fixing feet are supplied with each booster unit to rigidly fix the base. If vibration mounts are required these feet are reversed and the mounts supplied (optional extra) inserted thus raising the unit off the floor. Flexible pipe connections must be used when vibration mounts are fitted.

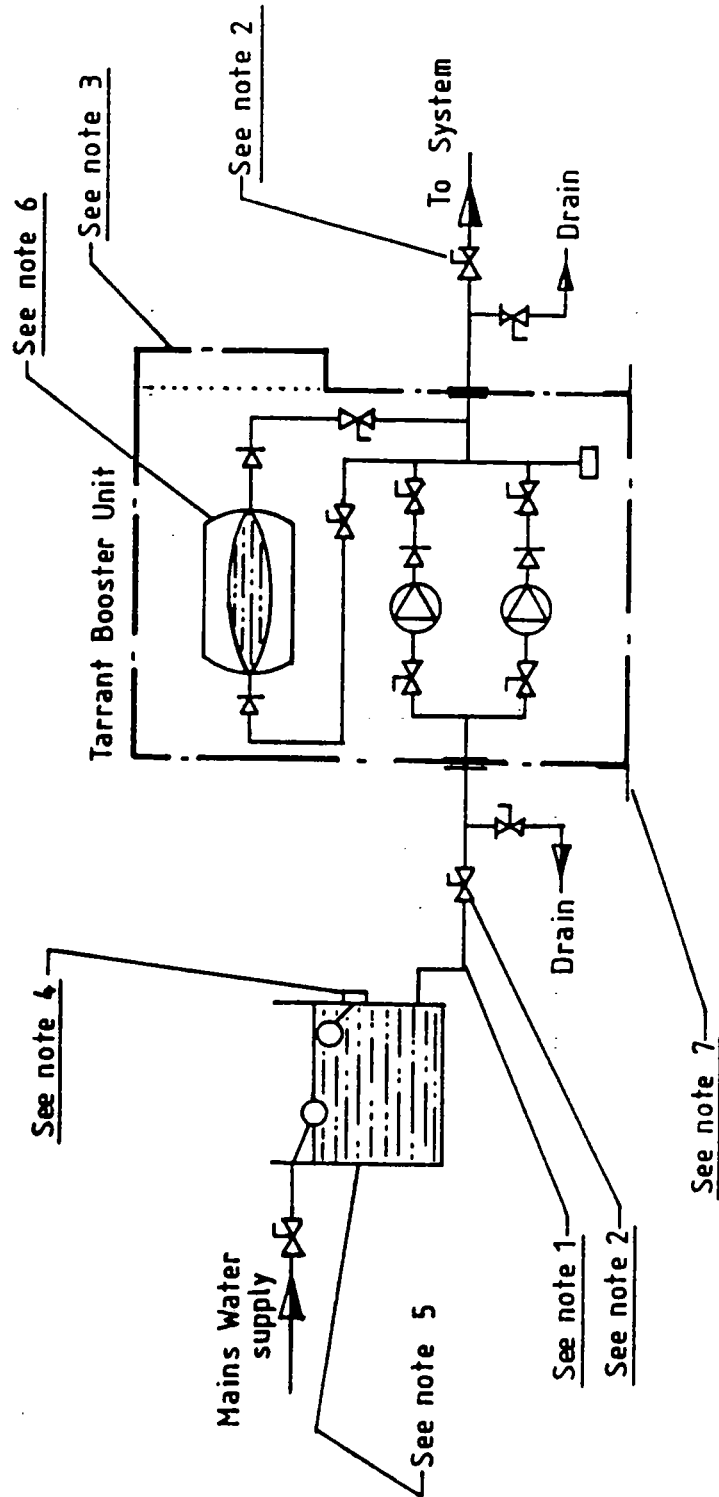

Refer to Fig N° 5 for note details

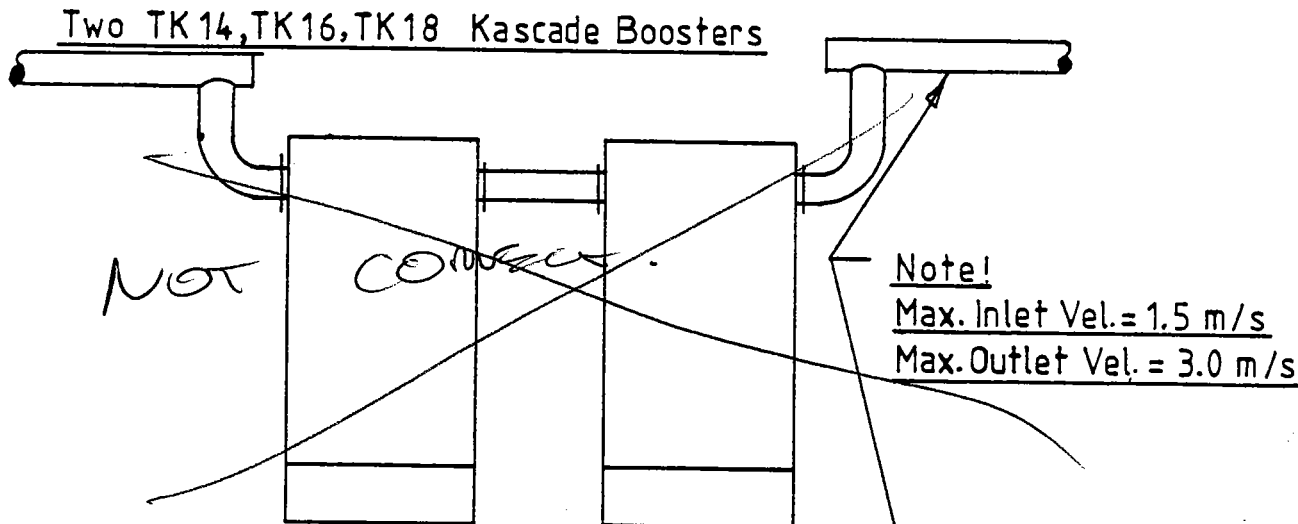

WVE GIVE THREE THE HEAD. AND THE FLOW

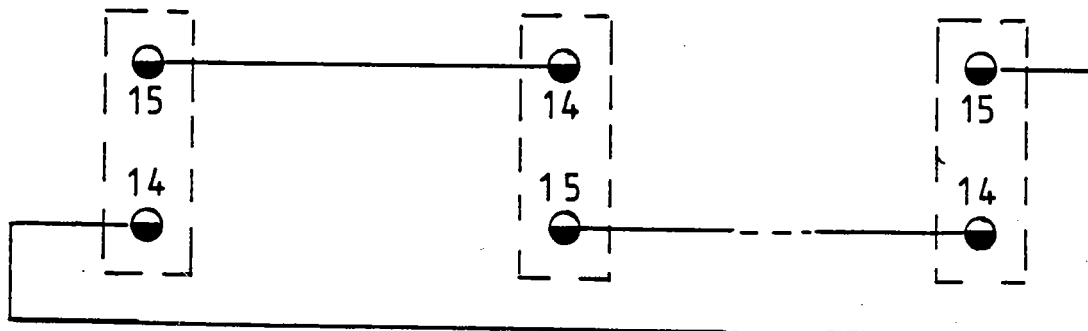
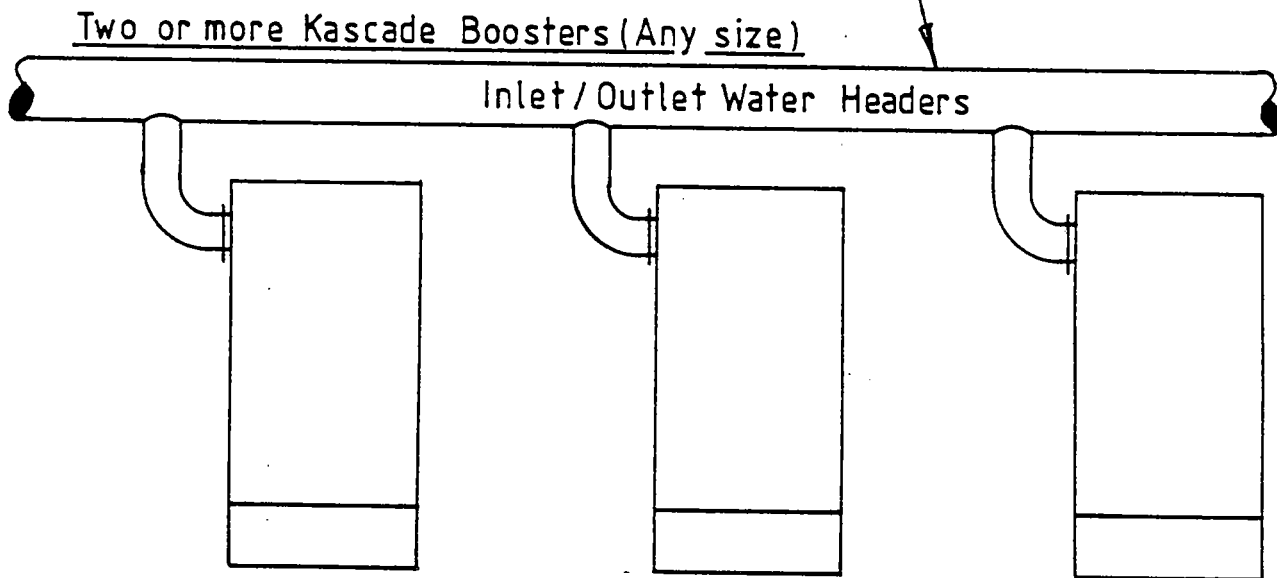

Kascade Master/Slave control terminal connection details

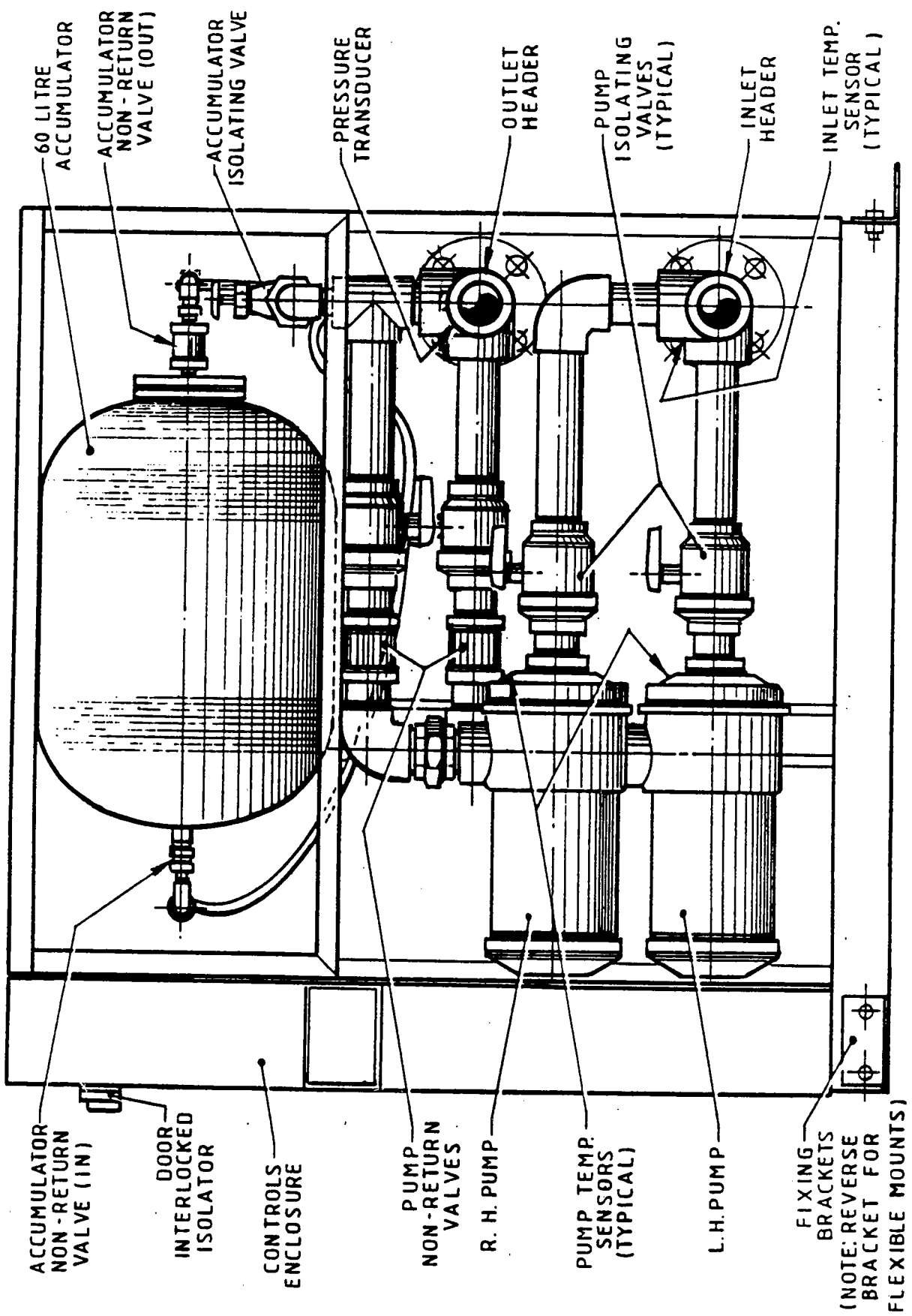

60 LITRE ACCUMULATOR
 ACCUMULATOR NON-RETURN VALVE (OUT)
 ACCUMULATOR ISOLATING VALVE
 PRESSURE TRANSDUCER
 OUTLET HEADER
 PUMP ISOLATING VALVES (TYPICAL)
 INLET HEADER
 INLET TEMP. SENSOR (TYPICAL)

ACCUMULATOR NON-RETURN VALVE (IN)
 DOOR-LOCKED INTERLOCKED ISOLATOR
 CONTROLS ENCLOSURE
 PUMP NON-RETURN VALVES
 R. H. PUMP
 PUMP TEMP. SENSORS (TYPICAL)
 L.H. PUMP
 FIXING BRACKETS (NOTE: REVERSE BRACKET FOR FLEXIBLE MOUNTS)



HAMWORTHY
heating products

Fig N° 9

DATA SHEET N°04:21:18

DATE 7/5/91

ISSUE 'A'

SUBJECT:- Tarrant Booster Unit

NOTE! MAXIMUM RATING 250VA.C.
RESISTIVE = 2 AMPS
INDUCTIVE = 1 AMP
*KASCADE BOOSTER UNIT ONLY

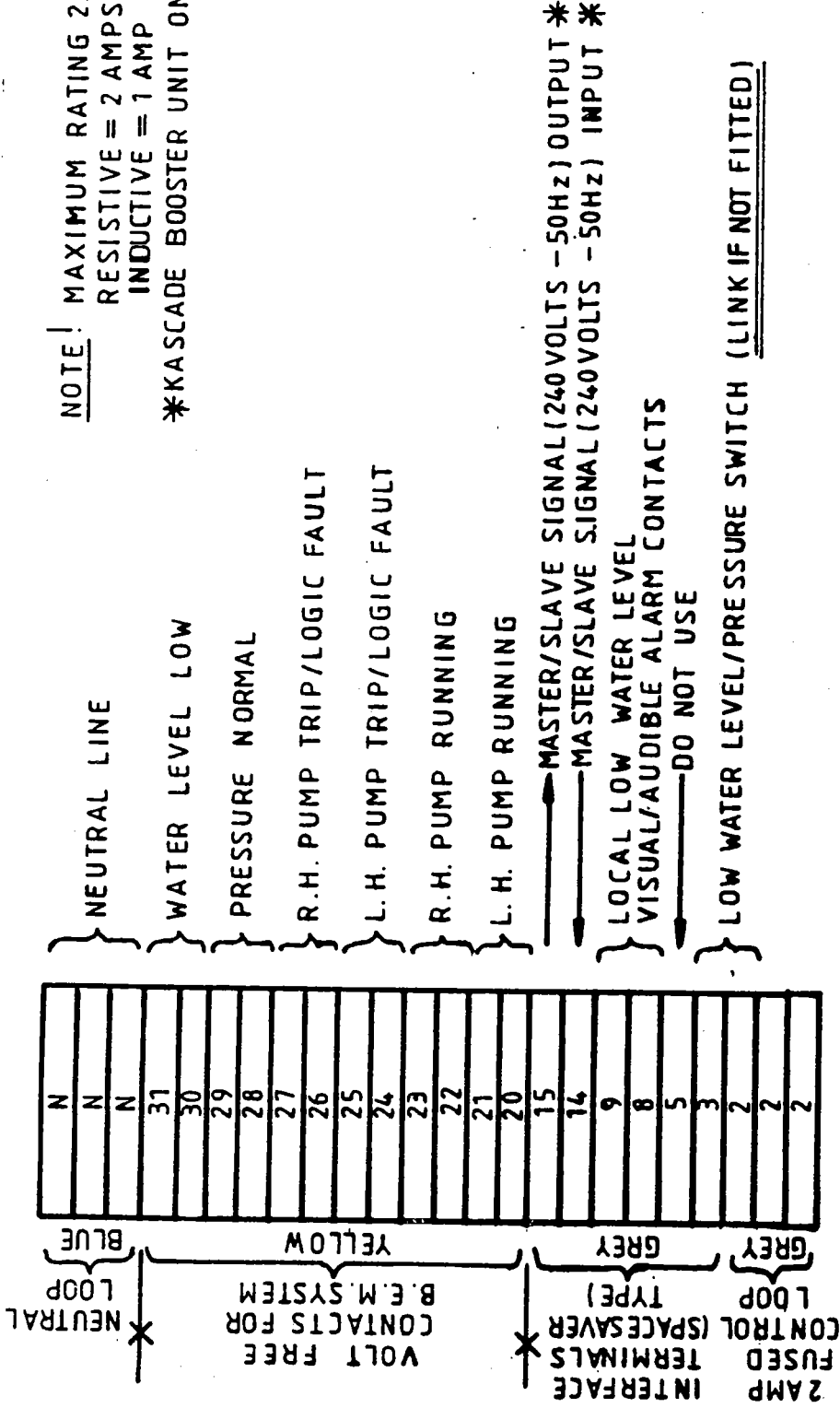

TARRANT BOOSTER UNIT SITE WIRING DETAILS

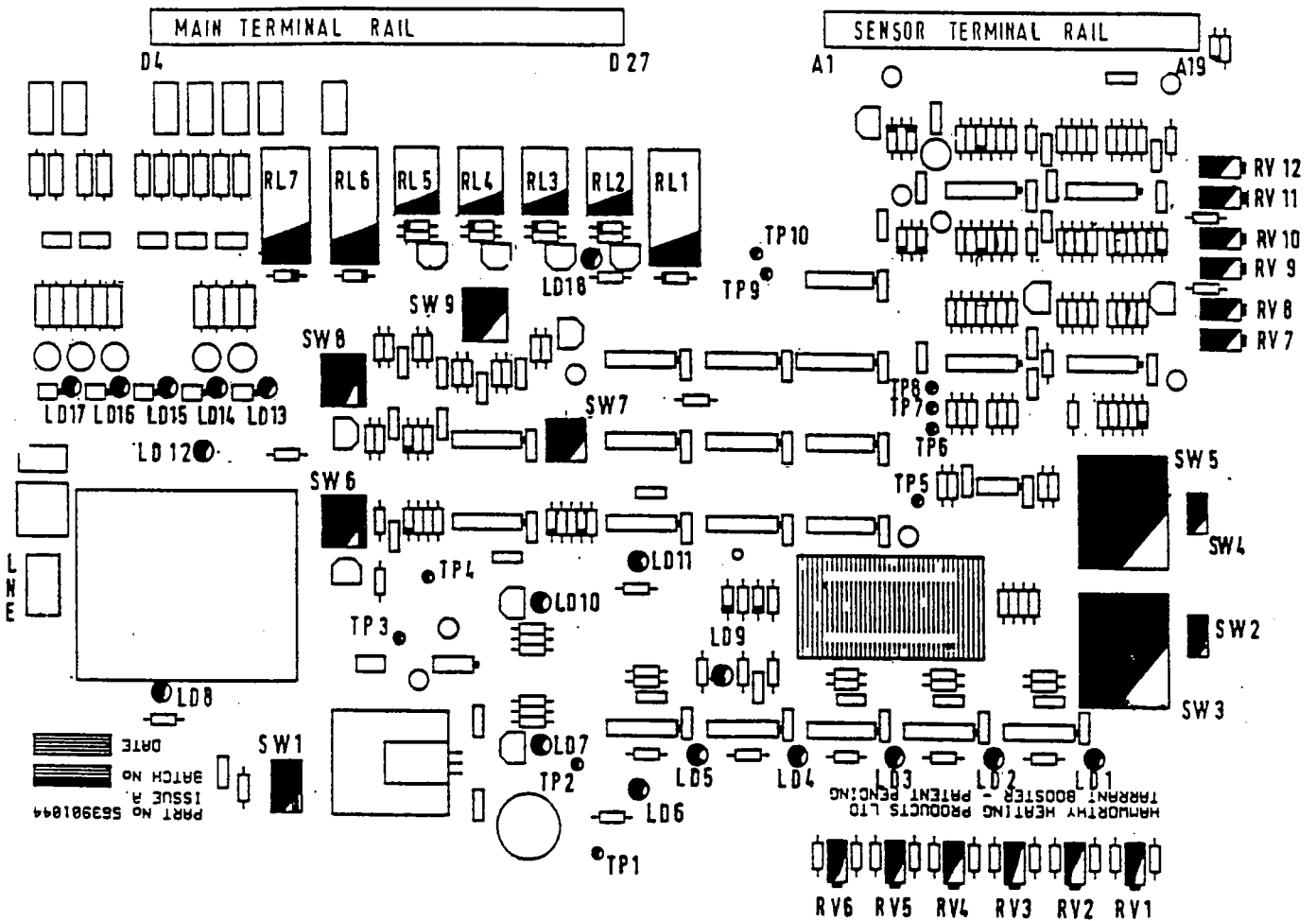

KEY:-

 VARIABLE RESISTOR

 RED L.E. DIODE

- RV 1 PRESSURE NORMAL SET POINT
- RV 2 TEMP. DIFFERENTIAL SET POINT
- RV 3 KW HIGH SET POINT
- RV 4 KW 2-1 SET POINT
- RV 5 KW 1-2 SET POINT
- RV 6 LOW PRESSURE SET POINT
- RV 7 L.H. PUMP TEMP. SENSOR ADJUSTER
- RV 8 PRESS. SENSOR GAIN ADJUSTER
- RV 9 PRESS. SENSOR ZERO ADJUSTER
- RV 10 R.H. PUMP TEMP SENSOR ADJUSTER
- RV 11 KW SENSOR ZERO ADJUSTER
- RV 12 KW SENSOR GAIN ADJUSTER

- LD 1 R.H.PUMP 60sec.TIMER
- LD 2 R.H.PUMP 5sec. TIMER
- LD 3 L.H.PUMP 60 sec.TIMER
- LD 4 L.H.PUMP 5 sec. TIMER
- LD 5 LOW PRESSURE
- LD 13 NORMAL WATER LEVEL
- LD 14 REMOTE 2nd PUMP SIGNAL
- LD 15 R.H.PUMP RUNNING
- LD 16 LH PUMP RUNNING
- LD 17 MASTER / SLAVE INPUT
- LD 18 KW HIGH

NOTE! RV 7 to 12 FACTORY SET DO NOT ADJUST



HAMWORTHY
heating products

Fig N° 11

DATA SHEET N°04:21:25

DATE 26/ 8 / 92

ISSUE 'B'

SUBJECT:- Tarrant Booster Unit

Control Logic Variable Resistor Settings

SETTING FIGURE																		
	TK	TK	TK	TK	TK	TK	TK	TK	TK	TG	TG	TG	TG	TG	TG	TG		
RV1	1.4	2.1	3.1	4.1	4.9	2.4	3.1	3.9	4.9	1.7	2.2	3.1	4.1	2.7	4.3	1.9	2.8	4.0
RV2	2	2	3	3	3	3	3	3	3	2	2	3	3	3	3	3	3	3
RV3	105	105	105	105	105	105	105	105	105	-	-	-	-	-	-	-	-	-
RV4	65	65	65	65	65	65	65	65	65	-	-	-	-	-	-	-	-	-
RV5	30	30	30	30	30	30	30	30	30	-	-	-	-	-	-	-	-	-
RV6	0.5	0.5	0.5	0.5	0.5	0.5	0.5	0.5	0.5	0.5	0.5	0.5	0.5	0.5	0.5	0.5	0.5	0.5
RV7	Set at inlet temperature									Set at inlet temperature								
RV8	Set at outlet pressure									Set at outlet pressure								
RV9	0*	0*	0*	0*	0*	0*	0*	0*	0*	0*	0*	0*	0*	0*	0*	0*	0*	0*
RV10	Set at inlet temperature									Set at inlet temperature								
RV11	0*	0*	0*	0*	0*	0*	0*	0*	0*	-	-	-	-	-	-	-	-	-
RV12	100*	100*	100*	100*	100*	100*	100*	100*	100*	-	-	-	-	-	-	-	-	-

*: At Specific Operating Conditions



HAMWORTHY
heating products

Fig N° 12

DATA SHEET N°04:21:27

DATE 26/8/92

ISSUE 'B'

SUBJECT:- Tarrant Booster Unit

List Of P.C.B. Component Functions

1) Light Emitting Diode (LD)

LD1-N° 2(RH) 60 sec. Timer
LD2-N° 2(RH) 5 sec. Timer
LD3-N° 1(LH) 60 sec. Timer
LD4-N° 1(LH) 5 sec. Timer
LD5-Low Pressure
LD6-N° 1(LH) Pump Fault (Fascia)
LD7-N° 1(LH) Pump Running (Fascia)
LD8-Low Water (Fascia)
LD9-Normal Pressure (Fascia)
LD10-N° 2(RH) Pump Running (Fascia)
LD11-N° 2(RH) Pump Fault (Fascia)
LD12-Power On (Fascia)
LD13-Normal Water Level
LD14-Remote 2nd Pump Signal
LD15-N° 2(RH) Pump Running
LD16-N° 1(LH) Pump Running
LD17-Master/Slave Input
LD18-Overload

2) Variable Resistor (RV)

RV1-Pressure Normal Set Point
RV2-Temp.Differential Set Point
RV3-Overload Set Point
RV4-2-1 Pump Set Point
RV5-1-2 Pump Set Point
RV6-Low Press.Diff. Set Point
RV7-N° 1(LH) Pump Temp Sensor Trim
RV8-Press. Transducer Gain Trim
RV9-Press. Transducer Zero Trim
RV10-N° 2(RH) Pump Temp Sensor Trim
RV11-kW. Transducer Zero Trim
RV12-kW Transducer Gain Trim

3) Switches (SW)

SW1-Reset
SW2-System Access/Press. Display
SW3-Run Mode Readings:-
Temp. Differential
Pump N° 2(RH) Temperature
Pump N° 1(LH) Temperature
Inlet Temperature
Power Ratio
Outlet Pressure
SW4-Commission/Run Display
SW5-Commissioned Set Points:-
Temp. Differential Set Point
Overload Set Point
2-1 Pump Set Point
1-2 Pump Set Point
Normal Pressure Set Point
Low Press.Diff. Set Point
SW6-N° 1(LH) Pump Off/Hand/Auto.
SW7-Kascade/Guardian Selector
SW8-N° 2(RH) Pump Off/Hand/Auto.
SW9-Master/Slave Selector

4) Test Points (TP)

TP 1-0 Volt Rail
TP 2- -15 Volt Rail
TP 3-Unregulated Supply Rail
TP 4- +15 Volt Rail
TP 5-Low Pressure Triggered
TP 6-Temp.Diff.High Triggered
TP 7-1-2 Pump Set Point
TP 8-2-1 Pump Set Point
TP 9-Pressure Normal Set Point
TP 10-Overload Triggered

TARRANT BOOSTER UNIT

SUBJECT:-General Fault Finding Data

<u>FAULT</u>	<u>POSSIBLE CAUSES</u>	<u>ACTION</u>
1) Pump motor will not run	No power to Booster	Check at distribution panel. Check door isolator
	No power to control system (power on indication 'off')	Check 2 amp control fuse. Check 500 mA P.C.B. fuse
	Booster at normal pressure (indication on fascia)	None
	Pump overheat switch tripped	Wait for pump case to cool
	Circuit breaker tripped	Manually re-set after investigation Circuit breaker incorrectly set. See motor F.L.C.
	Low water/inlet pressure	Check and rectify
	Pump fault indicated on fascia	Press. pump/system re-set button
	Pump starter contactor faulty	Replace
	Pump(s) switched to 'off' position on fascia	Switch to 'Auto'
	Incorrect P.C.B. switch settings	Refer to fault/ servicing section
2) Pump runs but does not build up pressure	Pump fault	Service or change pump
	Pump(s) not primed/noisy	Switch off pump(s) immediately. Refer to INSTALLATION AND STARTING INSTRUCTIONS. SECTION 3
	Pump direction incorrect	REFER TO INSTALLATION AND STARTING INSTRUCTIONS SECTION 3.
	System flow requirements higher than specified	Refer to installer/ consultant
	Non-return valve leaking	Service valve
	Impellor blocked or inlet blocked	Service unit

TARRANT BOOSTER UNIT

SUBJECT:- General Fault Finding Data

<u>FAULT</u>	<u>POSSIBLE CAUSES</u>	<u>ACTION</u>
3) Pump runs continuously	Pressure normal set point incorrectly set	Refer to Fig. 11 for technical data
	Pump(s) switched to manual on fascia	Switch to 'Auto'
	Non-return valve faulty	Service valve
	Temperature differential set point too high	Refer to Fig. 11 for technical data
	Pressure transducer faulty	Check pressure on display. Refer to fault finding/servicing section
	P.C.B. control system failure	Check and rectify
	Temperature sensor faulty	Check temperature on display. Refer to fault finding/servicing section
4) Excessive pump noise/vibration	Pump cavitating	Check inlet valve and pipework
	Pump bearings worn	Replace
	Pump flow excessive	Reduce flow requirement. Refer to original specification
	Inlet pipework to Booster too small/too long. Insufficient head from break tank	Replace or rectify
5) Pump cuts in/out rapidly	Accumulator charge pressure incorrect	Check accumulator pressure
	Non return valve not sealing correctly	Check valve seat Re-new if necessary
	Pump pressure switch	(FIRE - GUARD ONLY) Re-set to 0.5 bar



HAMWORTHY
heating products

Fig No 14

DATA SHEET No 04:21:16

DATE 26/8/92

ISSUE 'B'

SUBJECT:- Tarrant Booster Unit

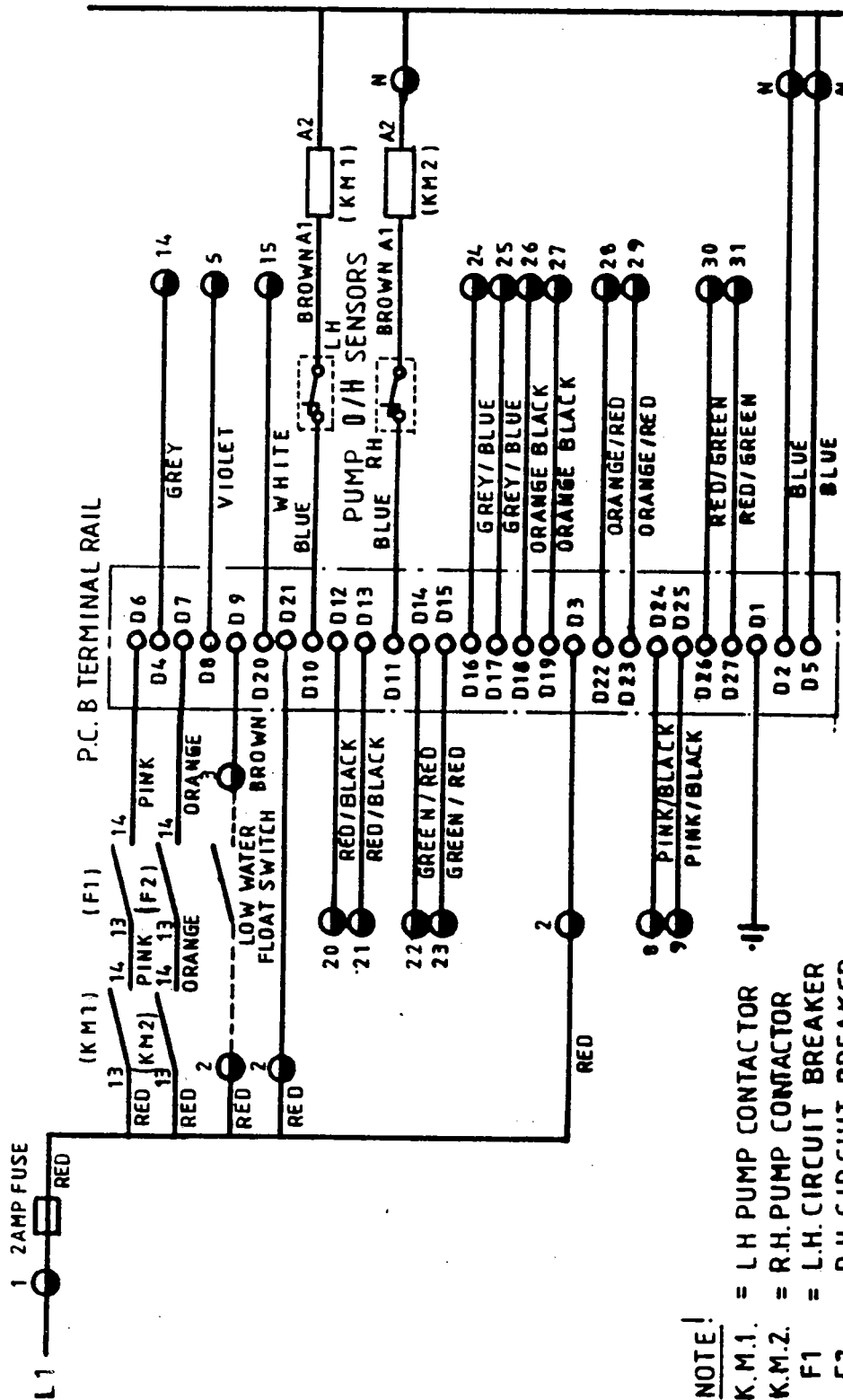

NOTE!

- K.M.1. = L.H PUMP CONTACTOR
- K.M.2. = R.H. PUMP CONTACTOR
- F1 = L.H. CIRCUIT BREAKER
- F2 = R.H. CIRCUIT BREAKER
- = TERMINAL

CABLE - 16/0.2mm (0.5 mm²)
O/H = OVER-HEAT SENSOR

**240 VOLT CONTROL & B.E.M.S.
VOLT FREE CONTACTS CIRCUIT
(SCHEMATIC ONLY)**



HAMWORTHY heating products

Fig No 15

DATA SHEET No 04:21:17

DATE 7/5/91

ISSUE 'A'

SUBJECT:- Tarrant Booster Unit

Terminal 1 6.5 - 35 vdc.
Terminal 3 0.5v DEFERRED or Pressure

Supply 6.5 - 35v d.c.

1 - 6 BAR.

0.833v PER BAR.

BETWEEN Terminal 3 & 4

OR A15 + A7

BOARD,

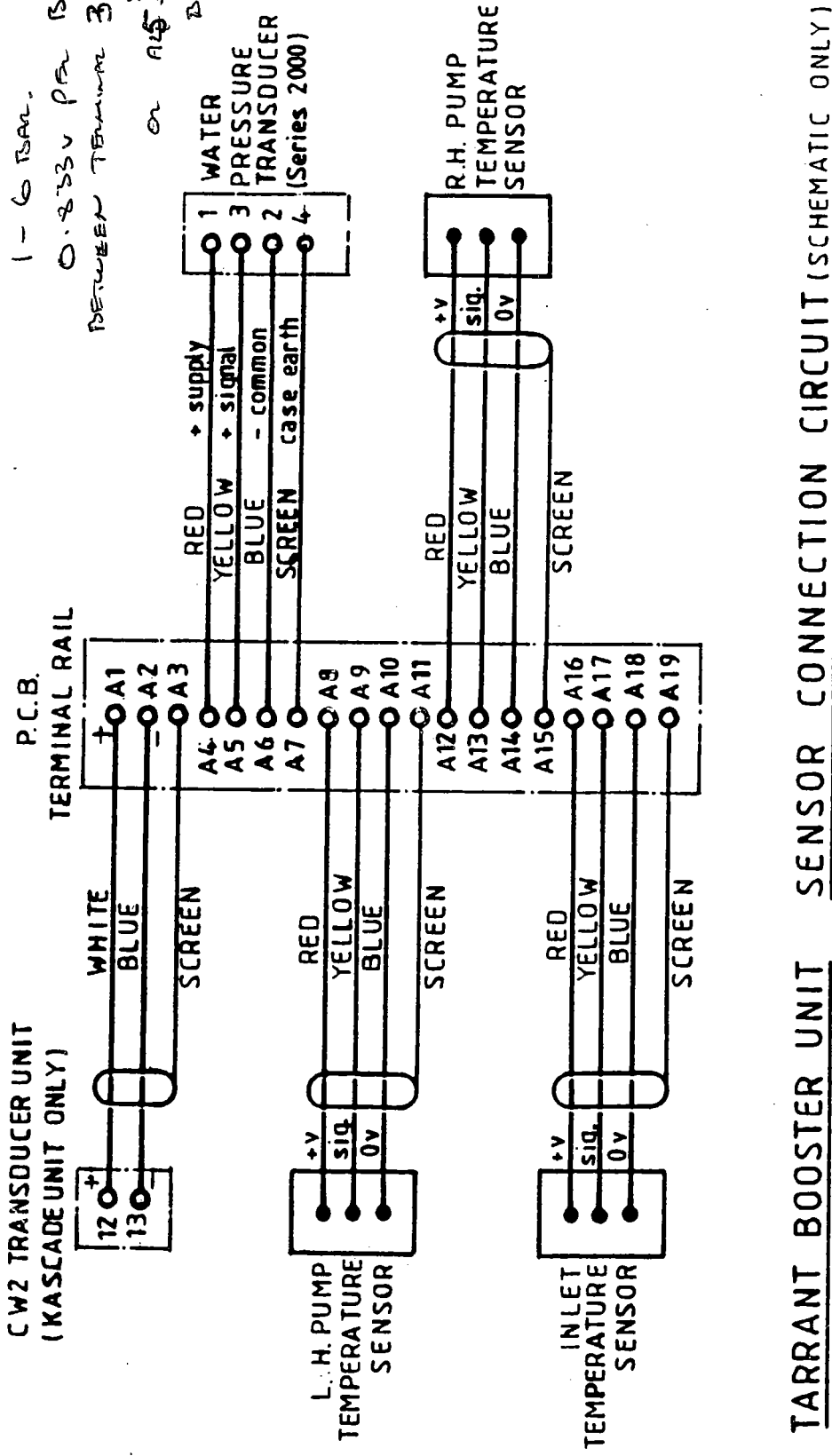

TARRANT BOOSTER UNIT SENSOR CONNECTION CIRCUIT (SCHEMATIC ONLY)

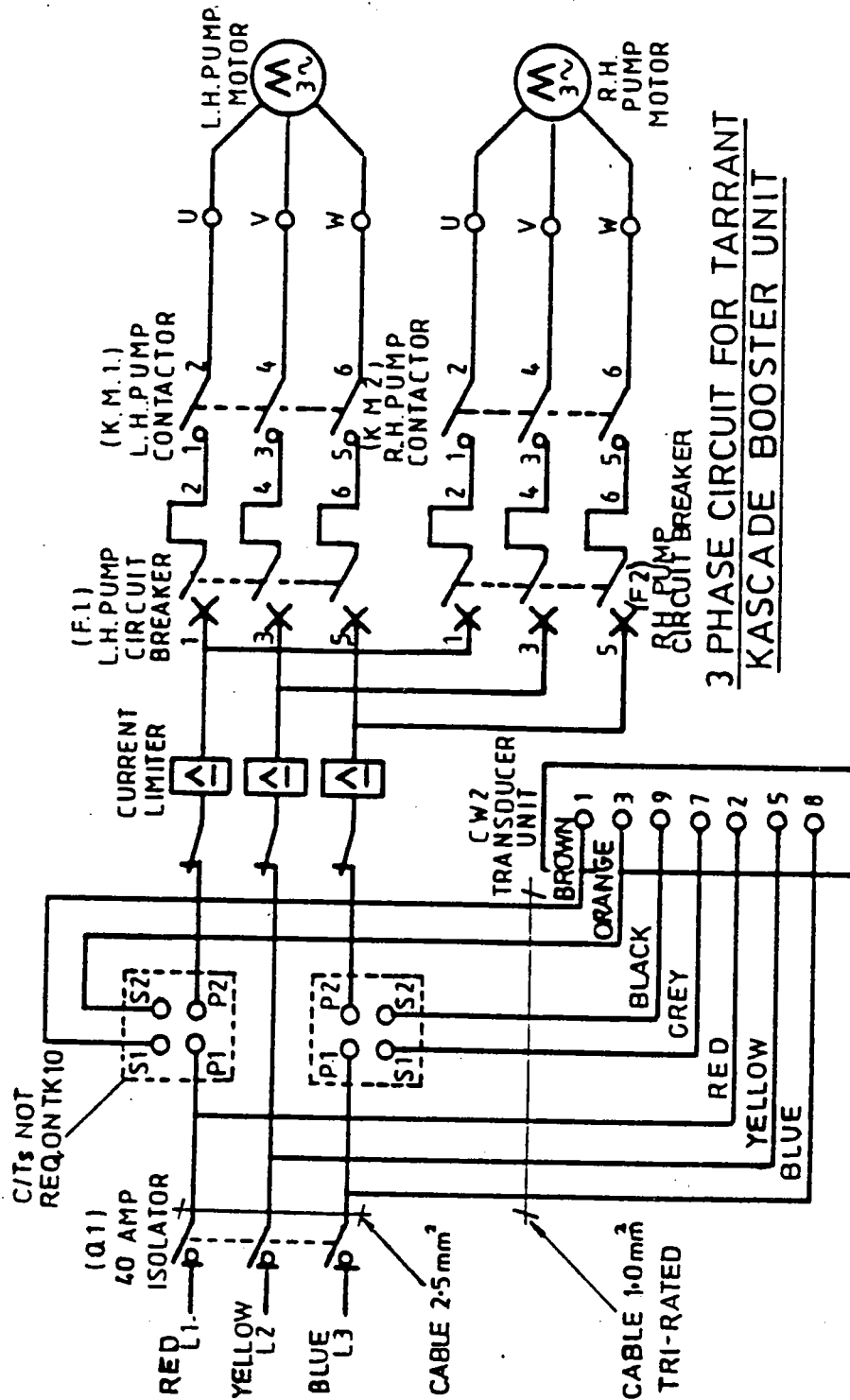

**3 PHASE CIRCUIT FOR TARRANT
CASCADE BOOSTER UNIT**

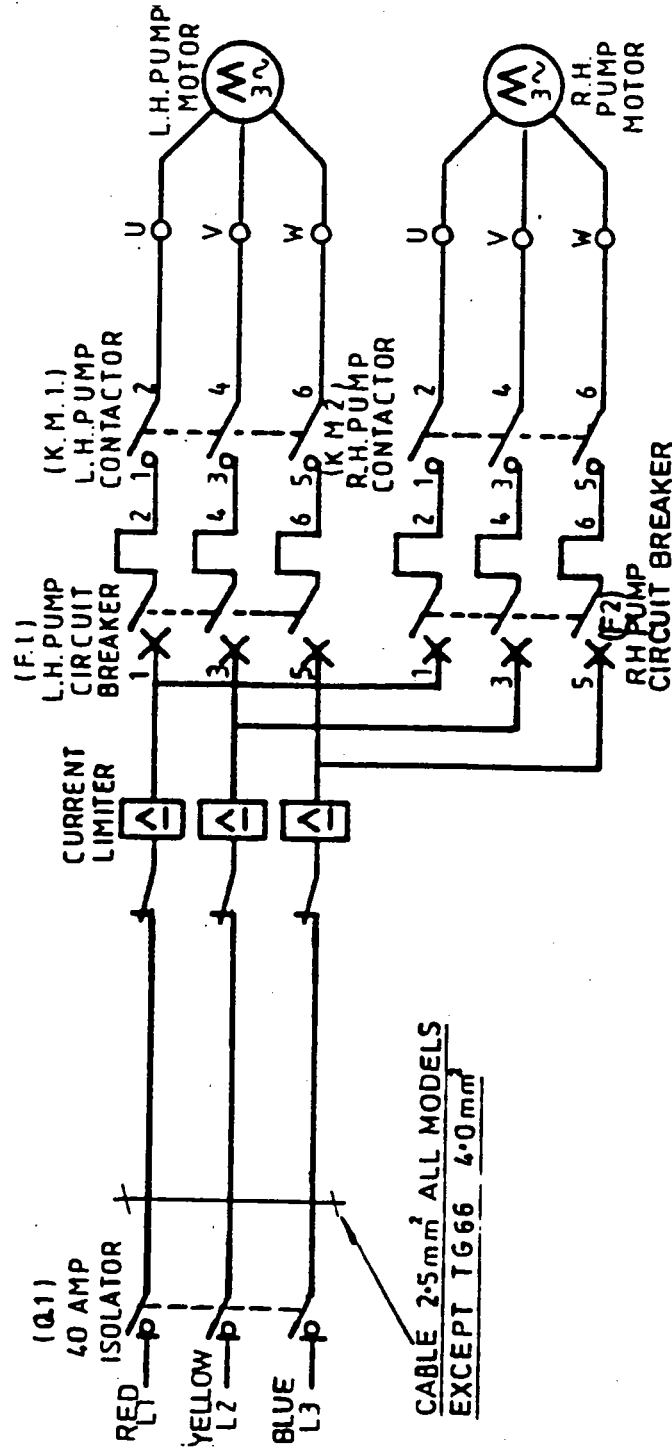

3 PHASE CIRCUIT FOR TARRANT
GUARDIAN BOOSTER UNIT



HAMWORTHY
heating products

Fig N° 18

DATA SHEET N°04:21:21

DATE 3/7/92

ISSUE 'B'

SUBJECT:- Tarrant Booster Unit

Three Phase Schematic Circuit (Star/Delta Starters)

Kascade Unit Only

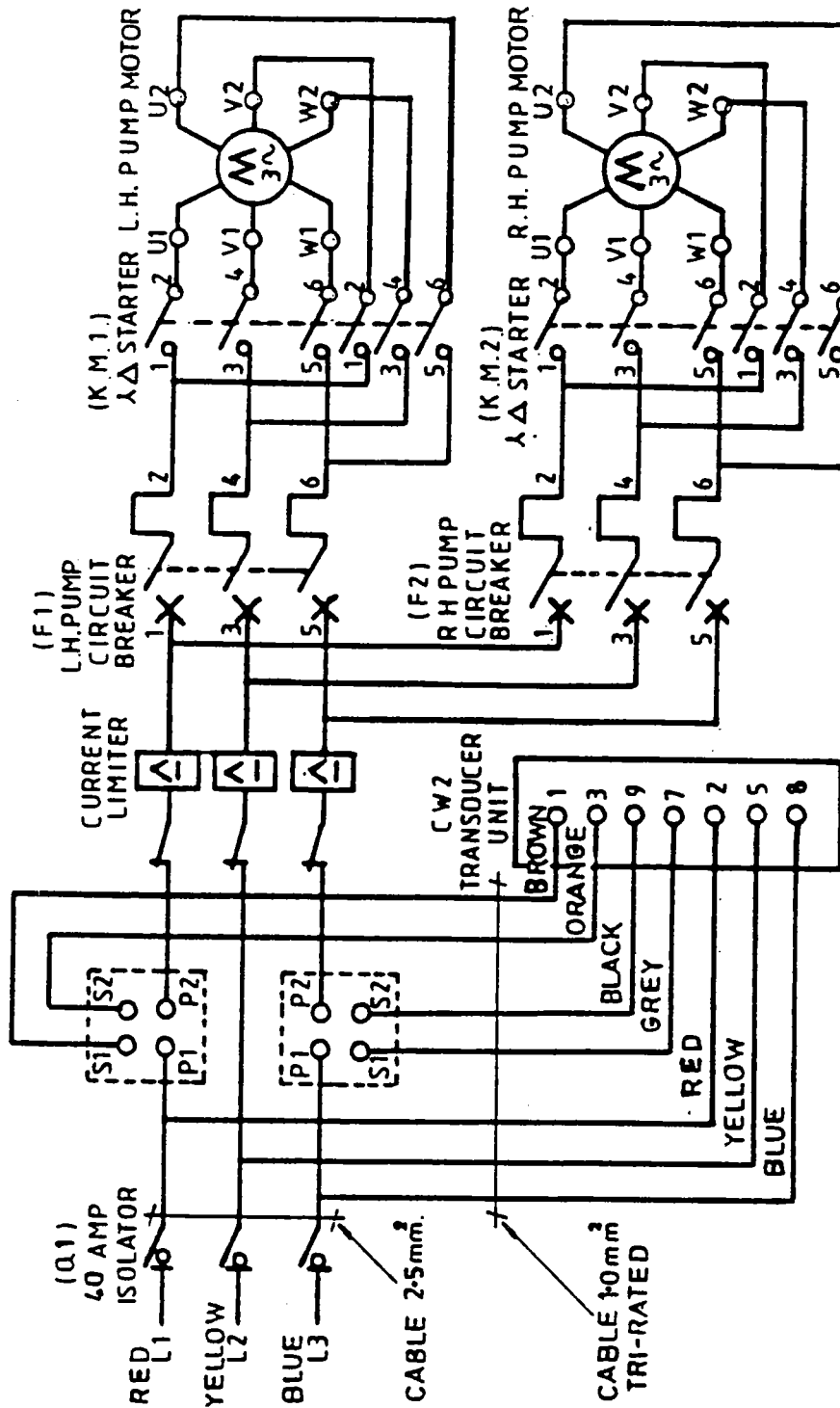

STAR DELTA KASCADE UNIT ONLY



HAMWORTHY
heating products

Fig N° 19

DATA SHEET N°04:21:22

DATE 3 / 7 / 92

ISSUE 'B'

SUBJECT: Tarrant Booster Unit

Three Phase Schematic Circuit (Star/Delta Starters)

Guardian Unit Only.

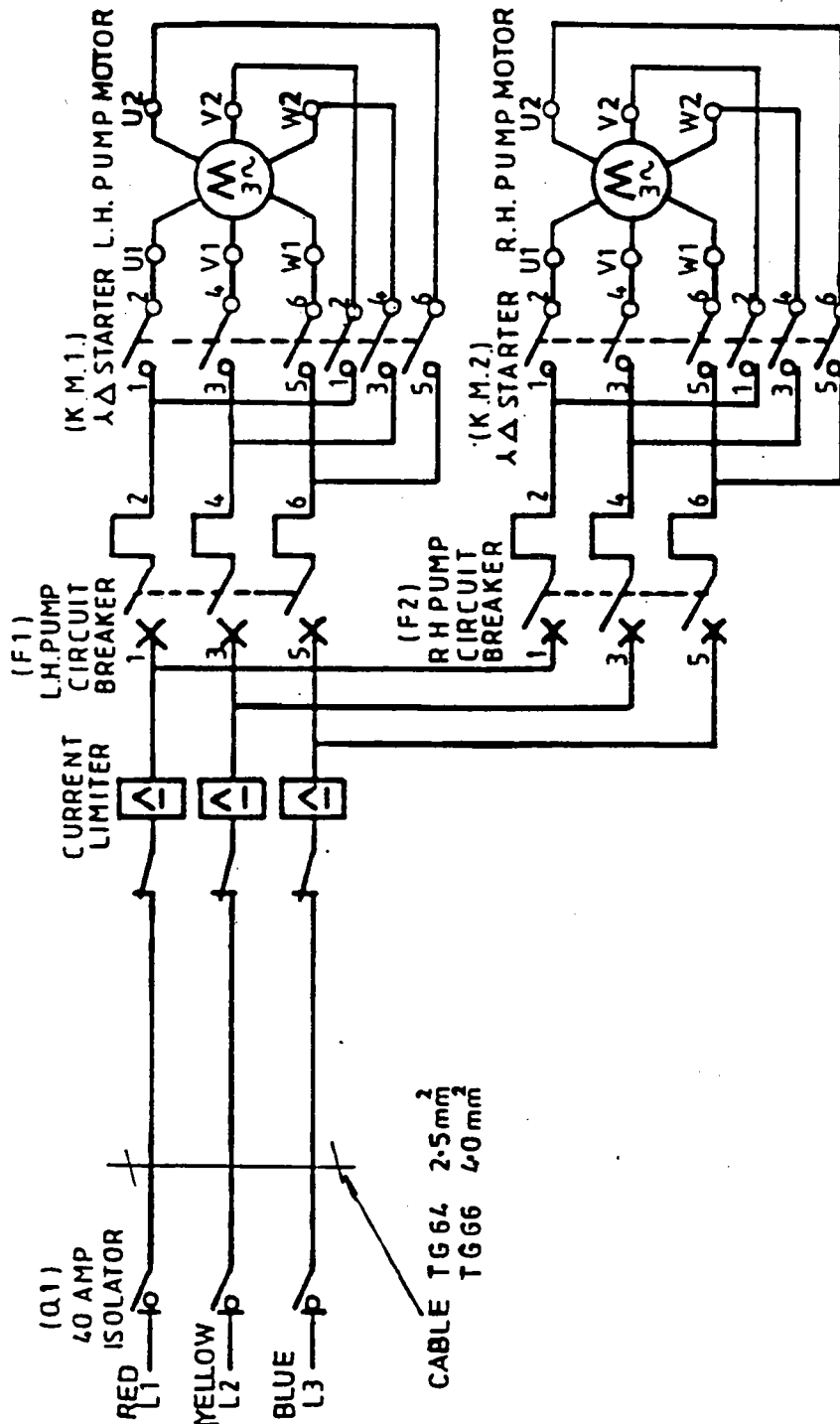

STAR DELTA GUARDIAN UNIT ONLY

CEK Pump

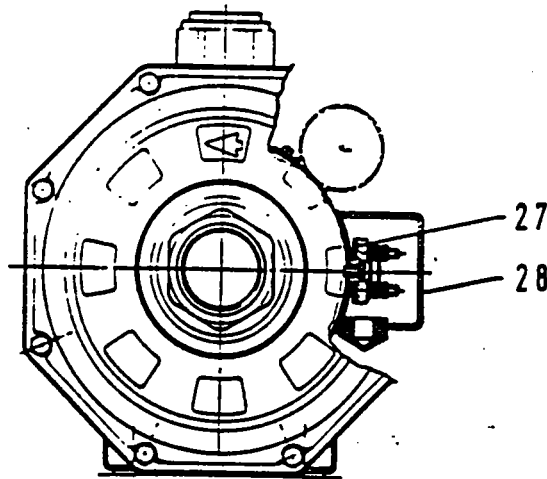
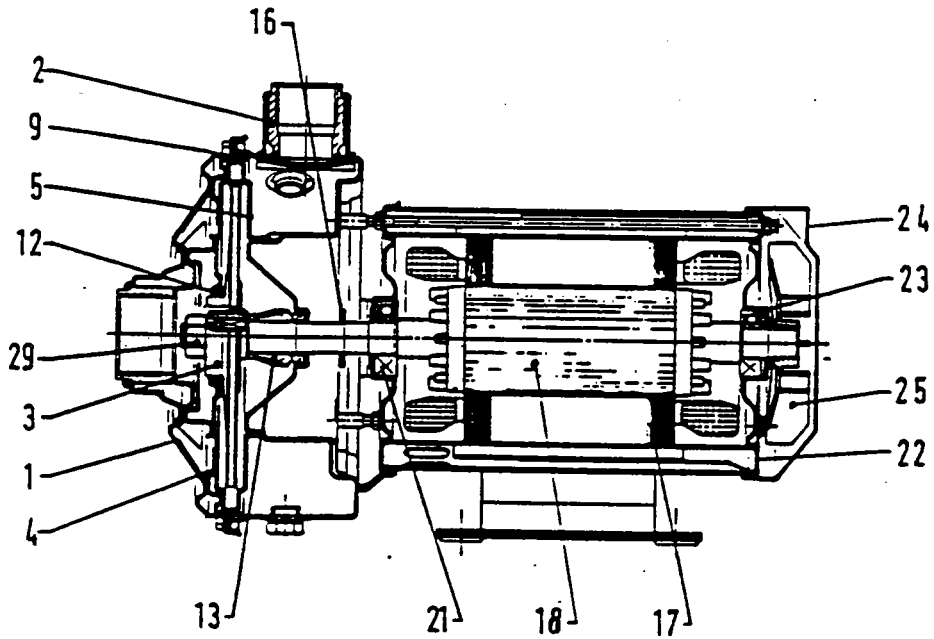

CK Pump

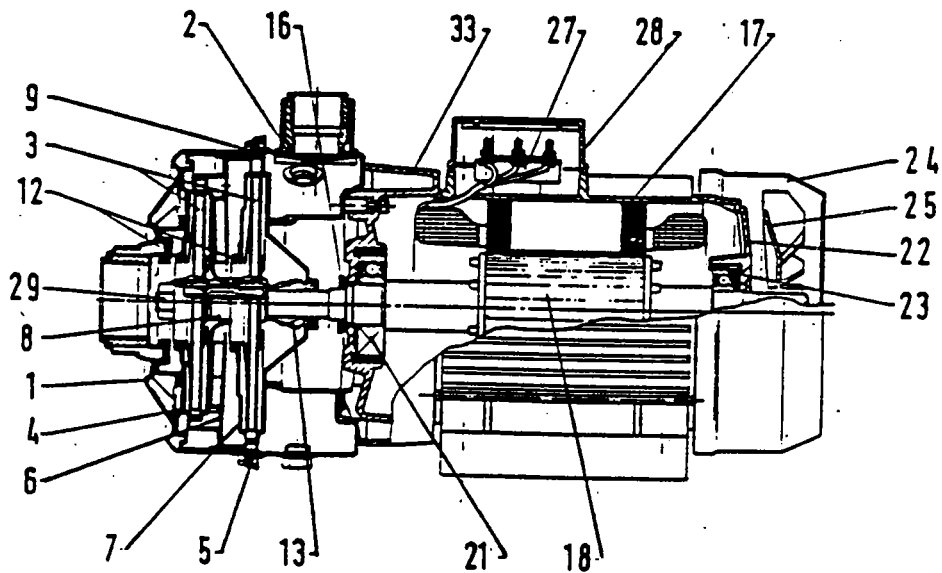



HAMWORTHY
heating products

Fig N° 21

DATA SHEET N°04:21:15

DATE 1/5/91

ISSUE 'A'

SUBJECT: Tarrant Booster Unit

HTS 25/32 Booster Pumps

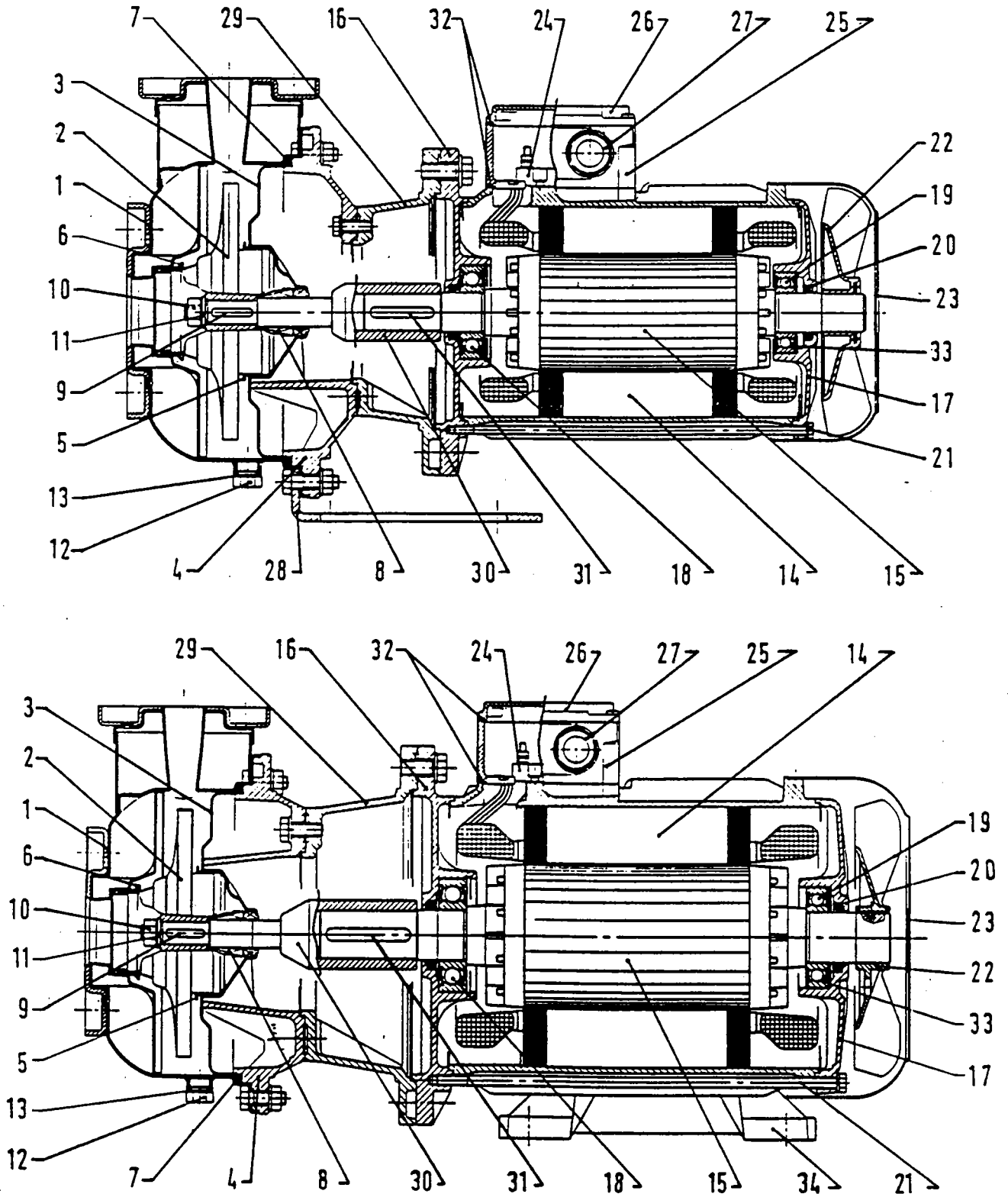

CUSTOMER SERVICES

APPLICATION

To supplement the detailed technical information booklets, technical advice on the application and use of the Hamworthy Heating product range is available from Poole and through the regional sales offices and accredited agents.

COMMISSIONING

A commissioning service is offered for all the Hamworthy Heating products. Commissioning by the manufacturer ensures the most efficient performance and correct operation is achieved.

Hamworthy commissioning reports are detailed and definitive. Such information reports on the original status of the plant are essential for the future routine maintenance and fault finding situations.

ROUTINE SERVICE

Hamworthy offer routine service contracts for all products. Planned maintenance of equipment by routine servicing reduces operational costs considerably below that associated with repair or breakdown approach. Regular servicing by Hamworthy trained staff ensures that all equipment is operating to optimum efficiency.

The frequency of visits to maintain installations up to required level is variable depending upon the equipment type and usage.

BREAKDOWN SERVICE, REPAIR, REPLACEMENT

Even when the commissioning and routine servicing has been carried out to the highest standard there are always occasions when the unexpected breakdowns occur. Hamworthy provide a rapid response breakdown, repair or replacement service through regional offices and accredited agents located throughout the UK.

SPARE PARTS

A comprehensive spare parts service is operated from our head office at Poole providing delivery, even for out of date items in most cases. In some instances spares may be available from regional offices and accredited agents.

Delivery of parts and components is normally from stock within 7 days. However, a 24 hour service is available for breakdowns and emergencies for the additional cost of the courier.

For your spares enquiries and orders please contact Carol Miller on 0202-665566.

To help Carol and her staff help you, please give as much detail as possible of the product type, serial number or any other identifying marks or codes.

**HEAD OFFICE (DEPOT & WORKS)
HAMWORTHY HEATING LIMITED
FLEETS CORNER,
POOLE, DORSET BH17 7LA
TEL: 0202 665566
FAX: 0202 665111**

OFFICES:

**MIDLANDS
HAMWORTHY HEATING LIMITED
Shady Lane,
Great Barr,
Birmingham B44 9EX
Tel: 021 360 7000
Fax: 021 325 0890**

ACCREDITED AGENTS:

**BERKS, BUCKS, OXON,
SURREY & WEST LONDON
FOWLER COMBUSTION CO. LIMITED
18 Oxford Road,
Wokingham,
Berks RG11 2XY
Tel: 0734 784350 Fax: 0734 771497**

**SOUTH (CENTRAL)
DRIVER ENGINEERING LIMITED
778 Wimborne Road,
Moordown,
Bournemouth BH9 2DX
Tel: 0202 525140 Fax: 0202 536442**

**BRISTOL AREA & SOUTH WALES
Mr J Hyde,
26 Waterloo Street,
Clifton,
Bristol BS8 4BP
Tel: 0272 744607**

**NORTH WEST (PART)
GILLIES MODULAR SERVICES
210-218 New Chester Road,
Birkenhead,
Merseyside L41 9BG
Tel: 051 666 1030**

**NORTH EAST (PART)
ALLISON HEATING PRODUCTS
12 Sunnyside Lane,
Cleadow Village,
Sunderland,
Tyne & Wear SR6 7XB
Tel: 091 536 2562**

**SCOTLAND
McDOWALL MODULAR SERVICES
97a Hawthorn Street,
Glasgow G22 6JD
Tel: 041 336 8795 Fax: 041 336 4444**

**NORTHERN IRELAND
McCAIG COLLIM LIMITED
94 Dargan Crescent,
Duncrue Industrial Estate,
Belfast BT3 9JP
Tel: 0232 777788**

**HAMWORTHY
Heating Products**

Offices and Agents throughout the world