

Application Guide



instinct

SOLO 110-155-199 & COMBI 155-199

NOTICE

- This manual is applicable to all Instinct boilers with AB in the serial number after the S or C (e.g. IN110SAB000001) which also operate with display software version 0.40 or later.
- If this guide does not apply to your boiler, Please visit triangletube.com to obtain the correct application guide.

WARNING

This document is intended to be used by a factory trained and qualified heating contractor or service technician only. Read all Instructions within this document and within the relevant Boiler Installation and Maintenance Manual before proceeding. It is recommended

to follow the procedures in the steps given. This guide does not replace the Installation and Maintenance manual. Skipping or missing procedural steps could result in substantial property damage, serious injury, or death.

NOTICE

- When receiving the Instinct unit, any claims for damage or shortage in shipment must be filed immediately against the transportation company by the consignee.
- Customer must register unit within sixty (60) days of installation in order to gain warranty coverage. See Warranty Card for details.
- Leave all documentation received with appliance with the owner for future reference.
- Installation and service should only be performed by a qualified installer or service technician.
- Installations and service should be performed by a licensed plumber or gas fitter in the Commonwealth of Massachusetts.

Sections

1.Boiler Pump Presets	3
2.Flexible Pump Configuration.....	5
3.Pump Selection	7
4.Instinct Solo Piping Diagrams	8
5.Instinct Combi Piping Diagrams.....	20

Figures

Fig. 1: Installer Button	3
Fig. 2: Installer Access Code.....	3
Fig. 3: CH & DHW Settings	3
Fig. 4: Boiler Settings.....	3
Fig. 5: Pump Settings.....	3
Fig. 6: Preset Pump Configuration.....	3
Fig. 7: Preset Pump Configuration.....	3
Fig. 8: Installer Button	5
Fig. 9: Installer Access Code.....	5
Fig. 10: CH & DHW Settings.....	5
Fig. 11: Boiler Settings	5
Fig. 12: Pump Settings	5
Fig. 13: Flexible Pump Config.....	5
Fig. 14: Flex. Relays.....	6
Fig. 15: Flex. Relay 1 Settings.....	6
Fig. 16: Flex. Relay 1 Save Option.....	6
Fig. 17: Instinct Solo Near Boiler Piping with Closely Spaced Tees.....	8
Fig. 18: Instinct Solo Near Boiler Piping with Hydraulic Separator	8
Fig. 19: Instinct Solo - Multiple Zones with Circulators.....	9
Fig. 20: Instinct Solo - Multiple Zones with Circulators - Domestic Piping Alternate	10
Fig. 21: Instinct Solo - Piping with Zone Valves	11
Fig. 22: Instinct Solo - Piping with Zone Valves - Domestic Piping Alternate	12
Fig. 23: Instinct Solo - Piping with Zone Valves and Zone Valve Control Panel.....	13
Fig. 24: Instinct Solo - Piping with Zone Valves and Zone Valve Control Panel - Domestic Piping Alternate	14
Fig. 25: Instinct Solo - Single Zone with Circulator.....	15
Fig. 26: Instinct Solo - Single Zone with Circulator - Domestic Piping Alternate	16
Fig. 27: Instinct Solo - Multiple Temperature Zones with Circulators.....	17
Fig. 28: Instinct Solo - Multiple Temperature Zones with Circulators - Domestic Piping Alternate.....	18
Fig. 29: Instinct Solo - Cascade Layout.....	19
Fig. 30: Instinct Combi Near Boiler Piping with Timesaver Manifold	20
Fig. 31: Instinct Combi Near Boiler Piping with Hydraulic Separator	20
Fig. 32: Instinct Combi - Multiple Zones with Circulators	21
Fig. 33: Instinct Combi - Single Zones with Circulator	22
Fig. 34: Instinct Combi - Multiple Temperature Zones with Circulators.....	23
Fig. 35: Instinct Combi - Multiple Zones with Zone Valves.....	24
Fig. 36: Instinct Combi - Multiple Zones with Zone Valves and Zone Valve Control Panel	24

Tables

Table 1: Instinct Preset Pump Configurations.....	4
Table 2: Instinct Solo Pump Requirements	7

Instinct Application Guide



1. Boiler Pump Presets

The boiler comes preconfigured for several preset pump outputs.

1. To access the Installer screen, touching simultaneously the up and down soft keys for 3 seconds as shown in Fig. 1.

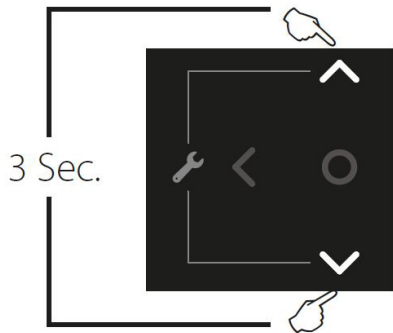

Fig. 1: Installer Button

2. Enter the installer access code "054" by using the **LEFT** and **RIGHT** buttons to select a digit and the **UP** and **DOWN** buttons to change the digit. Press the OK button to enter the access code.



Fig. 2: Installer Access Code

3. Press the OK button while the **CH & DHW Settings** icon is highlighted.

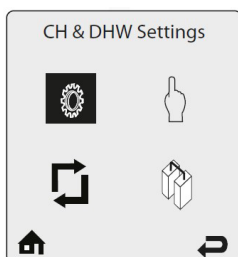

Fig. 3: CH & DHW Settings

4. Press the OK button while the **Boiler Settings** icon is highlighted.

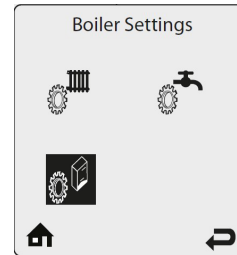

Fig. 4: Boiler Settings

5. Press the OK button while the **Pump Settings** option is highlighted.

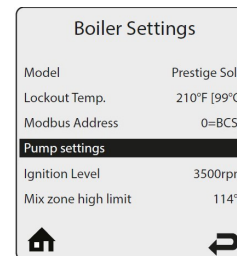

Fig. 5: Pump Settings

6. Press the OK button while the **Pump Settings** option is highlighted.

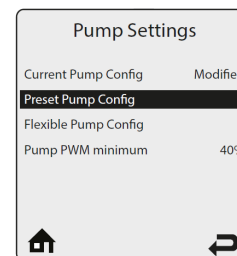

Fig. 6: Preset Pump Configuration

7. Scroll down the preset pump list and select one of the following options shown in Table 1.

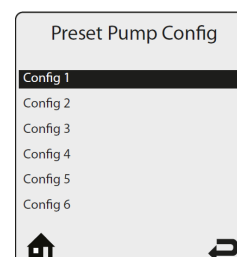

Fig. 7: Preset Pump Configuration

Table 1: Instinct Preset Pump Configurations

Preset Configuration	Boiler Pump Flex 1	CH1 Pump Flex 5	CH2 Pump Flex 3	DHW Pump Flex 2
A	CH1 Call CH2 Call DHW Call	CH1 Call CH2 Call		DHW Call
B & C Out of the box setting	CH1 Call CH2 Call DHW Call	CH1 Call	CH2 Call	DHW Call
D	CH1 Call CH2 Call DHW Call	CH1 Call CH2 Call	CH1 Call CH2 Call	DHW Call
E	CH1 Call CH2 Call	CH2 Call	CH2 Call	DHW Call
F	CH1 Call CH2 Call	CH1 Call CH2 Call	CH1 Call CH2 Call	DHW Call

Note: Other Presets are shown as available. These are non functional in the Instinct Boilers

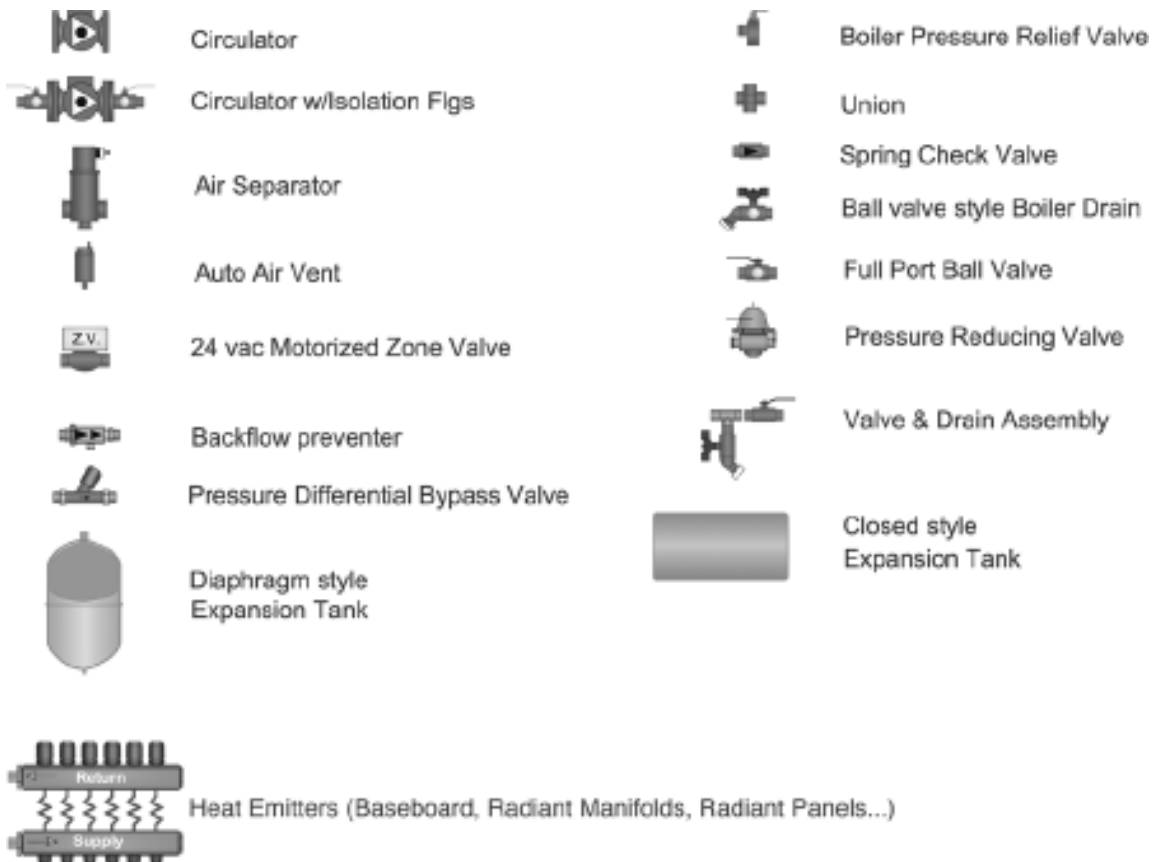

Fig. 8: Piping Layout Legend

Instinct Application Guide



2. Flexible Pump Configuration

This allows the installer to customize the flexible Pump Output (relays) to a specific installation arrangement that is not addressed in the Preset Pump Configuration options. There are a total of four Pump Output(relays) that must be set.

1. To access the Installer screen, touching simultaneously the up and down soft keys for 3 seconds as shown in Fig. 9.

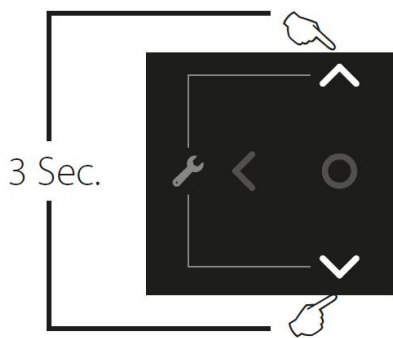

Fig. 9: Installer Button

2. Enter the installer access code "054" by using the **LEFT** and **RIGHT** buttons to select a digit and the **UP** and **DOWN** buttons to change the digit. Press the OK button to enter the access code.



Fig. 10: Installer Access Code

3. Press the OK button while the **CH & DHW Settings** icon is highlighted.

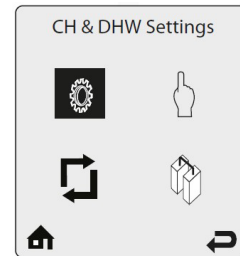

Fig. 11: CH & DHW Settings

4. Press the OK button while the **Boiler Settings** icon is highlighted.

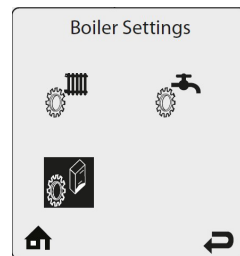

Fig. 12: Boiler Settings

5. Press the OK button while the **Pump Settings** option is highlighted.

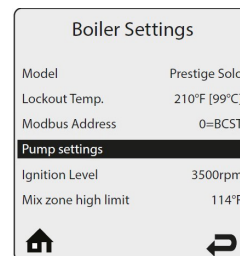

Fig. 13: Pump Settings

6. Press the OK button while **Flexible Pump Config** option is highlighted.

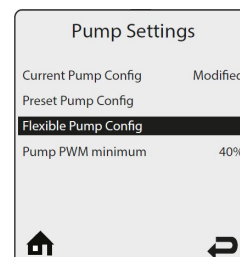

Fig. 14: Flexible Pump Config

- A list of 4 Flex Relays are clickable. These are the Boiler actions to be edited.

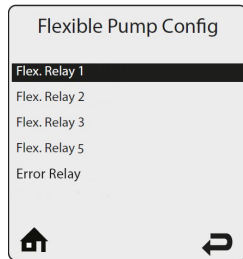

Fig. 15: Flex. Relays

- When selecting Flex Relay 1, the boiler pump actions are being edited.
 - When selecting Flex Relay 2, the DHW pump actions are being edited.
 - When selecting Flex Relay 3, the CH2 pump actions are being edited.
 - When selecting Flex Relay 5, the CH1 pump actions are being edited.
- Select the relay to be changed. Choose whether the relay will be on or off for any of the following calls: *CH1*, *CH2*, *DHW*, *MIX OPEN*, *MIX CLOSE*, *ERROR*, *FLAME*.
 - When selecting CH1, the relay is activated at CH1 demand.
 - When selecting CH2, the relay is activated at CH2 demand.
 - When selecting DHW, the relay is activated at DHW demand.
 - Mix Open is not functional in the Instinct Boilers.
 - Mix Close is not functional in the Instinct Boilers.
 - When selecting ERROR, the relay is activated on error.
 - When selecting FLAME, the relay is activated when appliance is running and a flame signal has been detected.

- Once the Relay's actions have been selected, scroll down and hit enter on the **Save and Exit** option at the bottom. This relay shown in Fig. 16 is set to turn on the pump wired to the CH1 terminal only for CH1 calls.

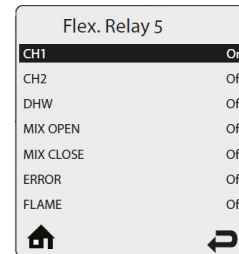

Fig. 16: Flex. Relay 1 Settings

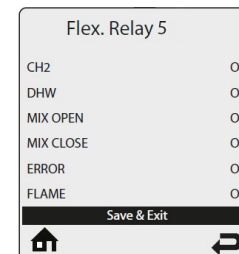

Fig. 17: Flex. Relay 1 Save Option

NOTICE

The options will not be saved when quick exiting (hitting the house or back arrow at the bottom of the menu).

Instinct Application Guide



3. Pump Selection

Refer to Table 2 for the Boiler pump recommendations when using primary secondary piping.

Table 2: Instinct Solo Pump Requirements

Model	Heating Capacity	Temperature Rise	Required Boiler Flow	Minimum Boiler Pipe Size	Minimum Boiler Pump Size		
					Grundfos	Taco	Wilo
Instinct Solo 110	102 MBH	20°F	10.2 GPM	1"	UPS 15-58FC	0015-MSF3	Star S 21 F
		25°F	8.2 GPM	1"	UPS 15-58FC	007-F5	Star S 21 F
		30°F	6.8 GPM	1"	UPS 15-58FC	007-F5	Star S 21 F
		35°F	5.8 GPM	1"	UPS 15-58FC	007-F5	Star S 21 F
Instinct Solo 155	143 MBH	20°F	14.3 GPM	1.25"	UPS 26-99FC	0013-MSF1	Star S 33 FC
		25°F	11.4 GPM	1.25"	UPS 26-99FC	0013-MSF1	Star S 33 FC
		30°F	9.5 GPM	1"	UPS 15-58FC	0015-MSF3	Star S 21 F
		35°F	8.2 GPM	1"	UPS 15-58FC	007-F5	Star S 21 F
Instinct Solo 199	185 MBH	20°F	18.5 GPM	1.5"	UPS 43-100 F	2400-30-3P	Top S 1.25 x 35
		25°F	14.8 GPM	1.25"	UPS 26-99FC	0013-MSF1	Star S 33 FC
		30°F	12.3 GPM	1.25"	UPS 26-99FC	0013-MSF1	Star S 33 FC
		35°F	10.6 GPM	1"	UPS 15-58FC	0015-MSF3	Star S 21 F

4. Instinct Solo Piping Diagrams

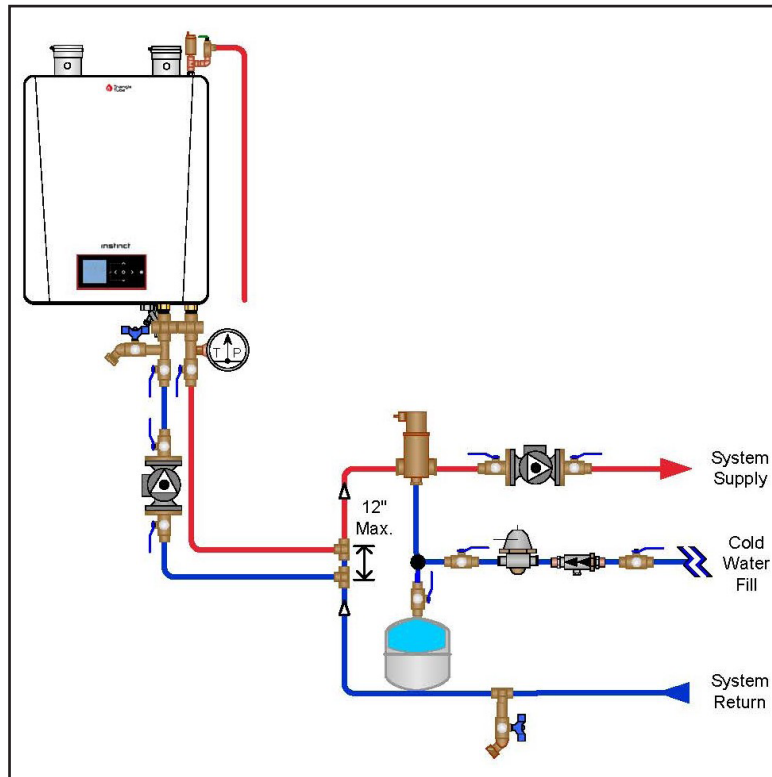

Fig. 18: Instinct Solo Near Boiler Piping with Closely Spaced Tees

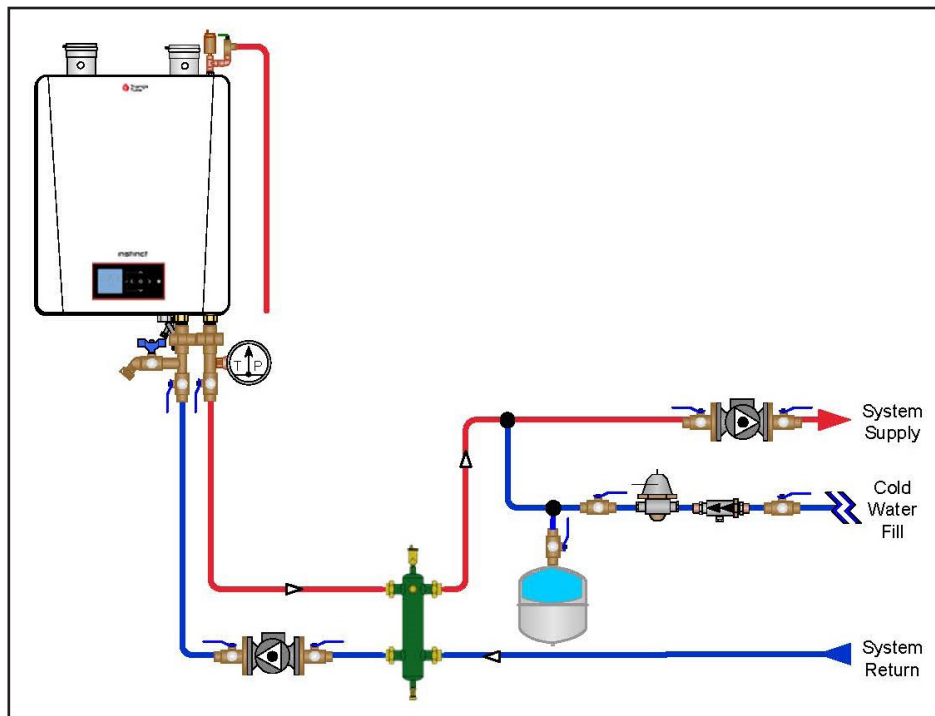

Fig. 19: Instinct Solo Near Boiler Piping with Hydraulic Separator

Preset B Pump Configuration

Heat Call	Boiler Pump	CH1 Pump	CH2 Pump	DHW Pump
CH1	ON	ON	OFF	OFF
CH2	ON	OFF	ON	OFF
DHW	ON	OFF	OFF	ON

Note: the boiler is set up in this configuration out of the box

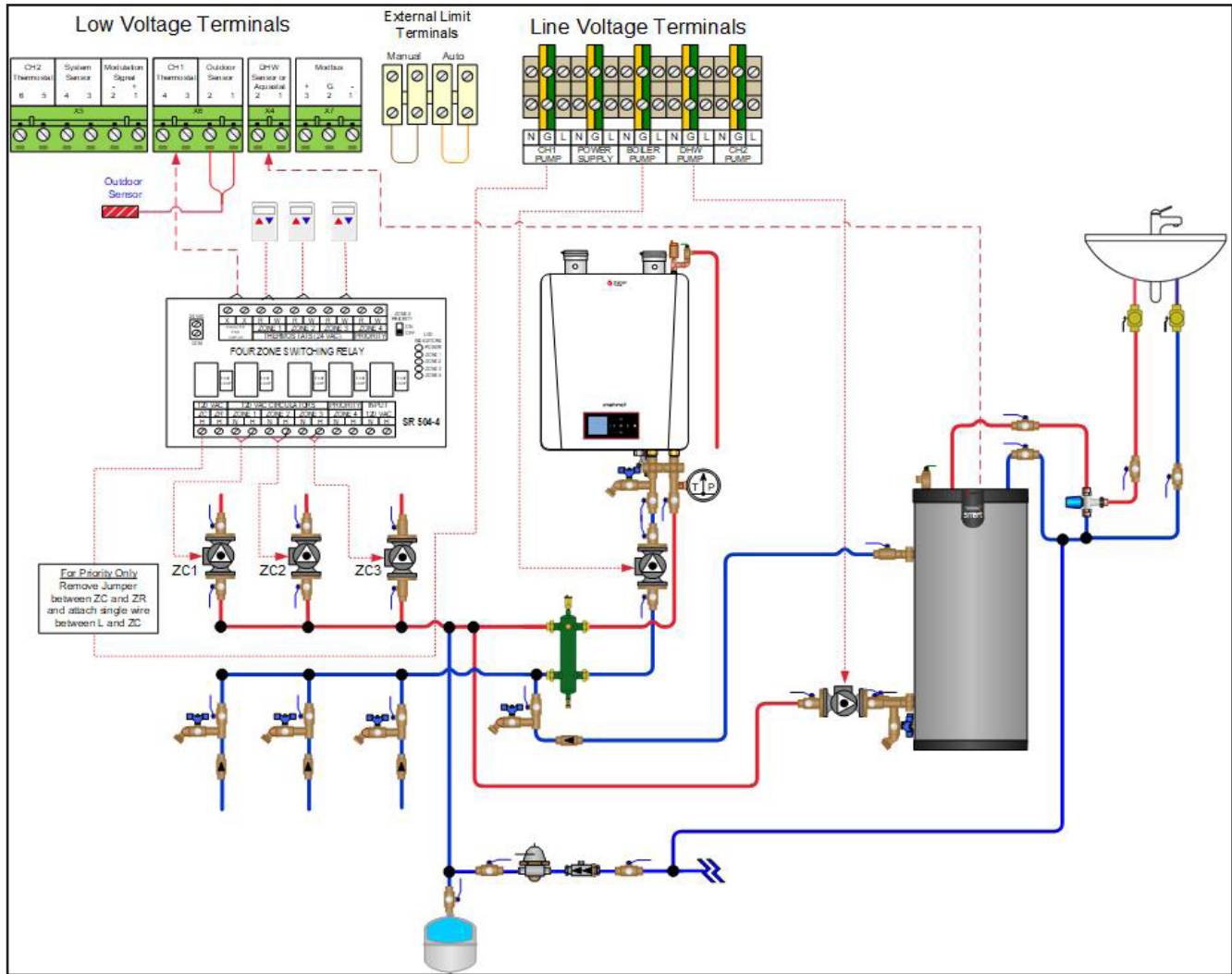

Fig. 20: Instinct Solo - Multiple Zones with Circulators

NOTICE

Piping layout is shown with a Hydraulic Separator. Closely spaced tees and an air separator can be used as shown in Fig. 18 on page 8.

Layout is shown with separate Circulator and check valve. If using a circulator with internal check valve, the corresponding check valve is unnecessary.

Preset E Pump Configuration

Heat Call	Boiler Pump	CH1 Pump	CH2 Pump	DHW Pump
CH1	ON	ON	OFF	OFF
CH2	ON	OFF	ON	OFF
DHW	OFF	OFF	OFF	ON

Note: the boiler pump settings must be changed for this arrangement

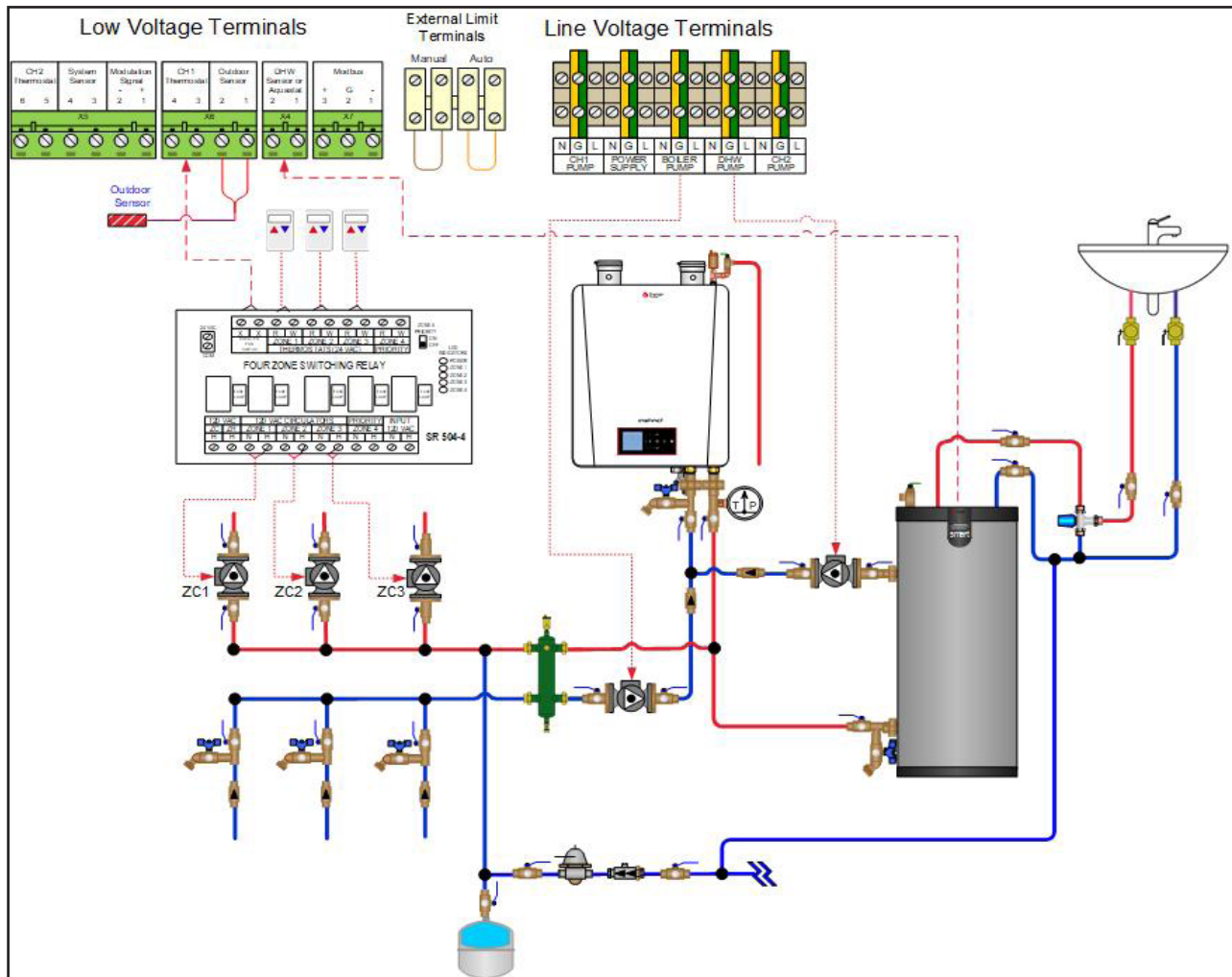

Fig. 21: Instinct Solo - Multiple Zones with Circulators - Domestic Piping Alternate

NOTICE

Piping layout is shown with a Hydraulic Separator. Closely spaced tees and an air separator can be used as shown in Fig. 18 on page 8.

Layout is shown with separate Circulator and check valve. If using a circulator with internal check valve, the corresponding check valve is unnecessary.

Preset A or D Pump Configuration (D Shown)

Heat Call	Boiler Pump	CH1 Pump	CH2 Pump	DHW Pump
CH1	ON	ON	ON	OFF
CH2	ON	ON	ON	OFF
DHW	ON	OFF	OFF	ON

Note: the boiler pump settings must be changed for this arrangement

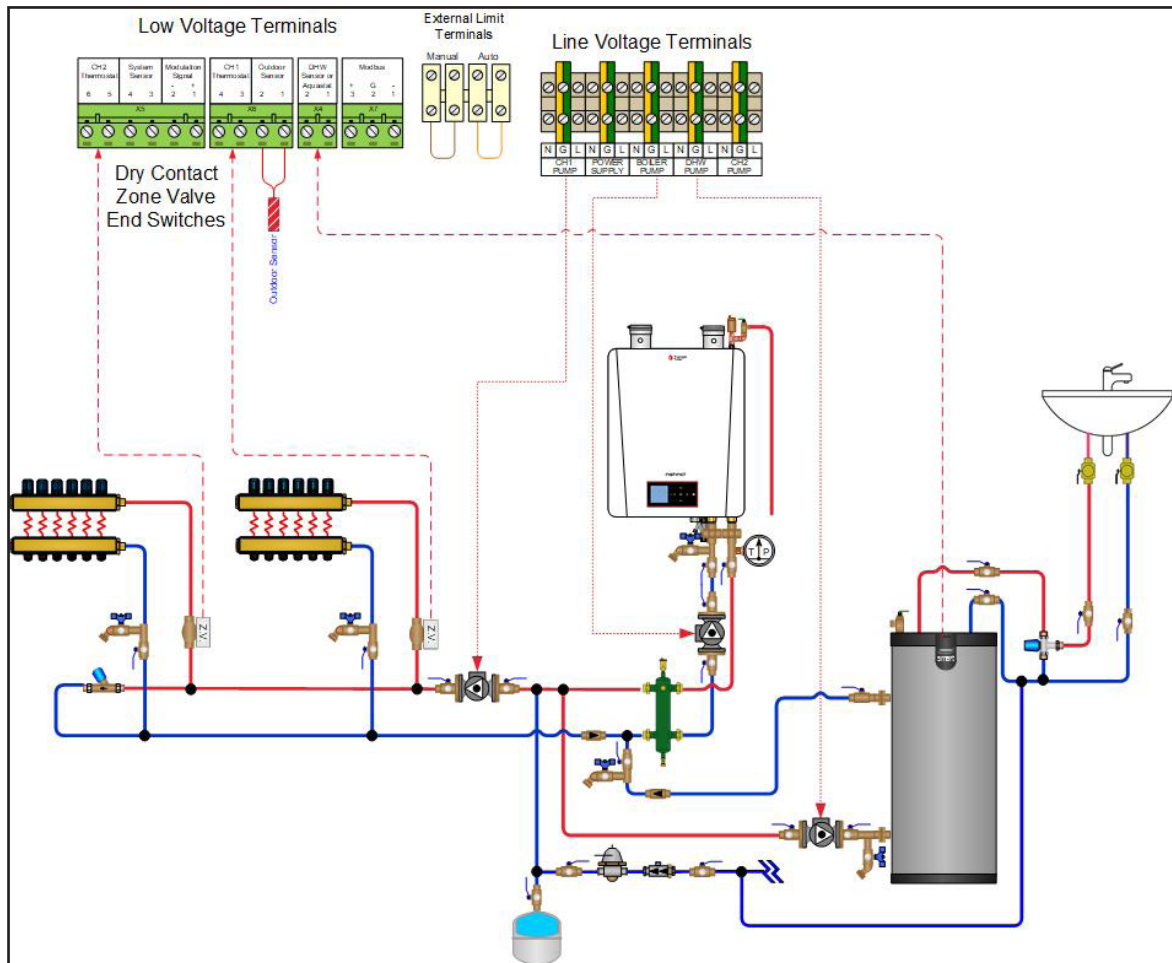

Fig. 22: Instinct Solo - Piping with Zone Valves

NOTICE

Piping layout is shown with a Hydraulic Separator. Closely spaced tees and an air separator can be used as shown in Fig. 18 on page 8.

Preset F Pump Configuration

Heat Call	Boiler Pump	CH1 Pump	CH2 Pump	DHW Pump
CH1	ON	ON	ON	OFF
CH2	ON	ON	ON	OFF
DHW	OFF	OFF	OFF	ON

Note: the boiler pump settings must be changed for this arrangement

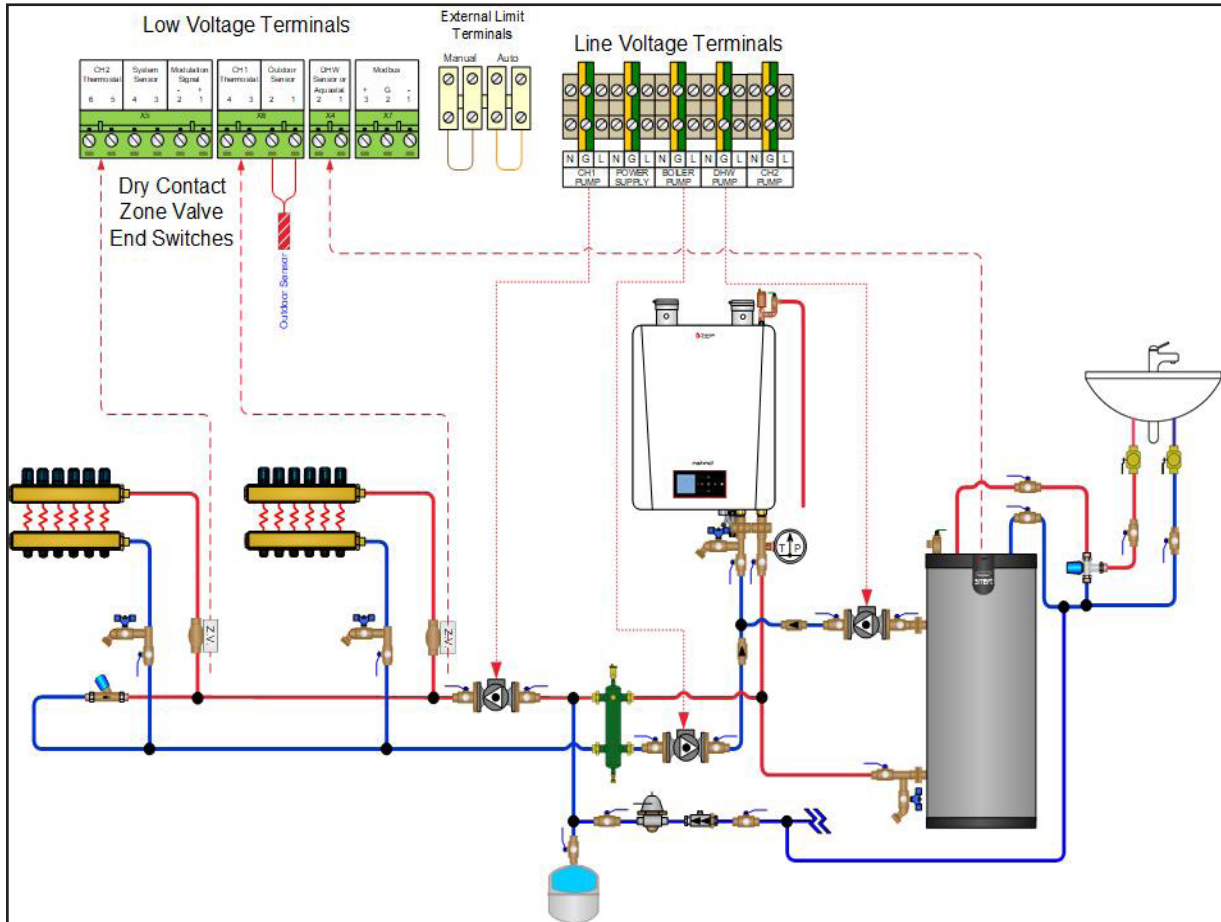

Fig. 23: Instinct Solo - Piping with Zone Valves - Domestic Piping Alternate

NOTICE

Piping layout is shown with a Hydraulic Separator. Closely spaced tees and an air separator can be used as shown in Fig. 18 on page 8.

Preset B Pump Configuration

Heat Call	Boiler Pump	CH1 Pump	CH2 Pump	DHW Pump
CH1	ON	ON	OFF	OFF
CH2	ON	OFF	ON	OFF
DHW	ON	OFF	OFF	ON

Note: the boiler is set up in this configuration out of the box

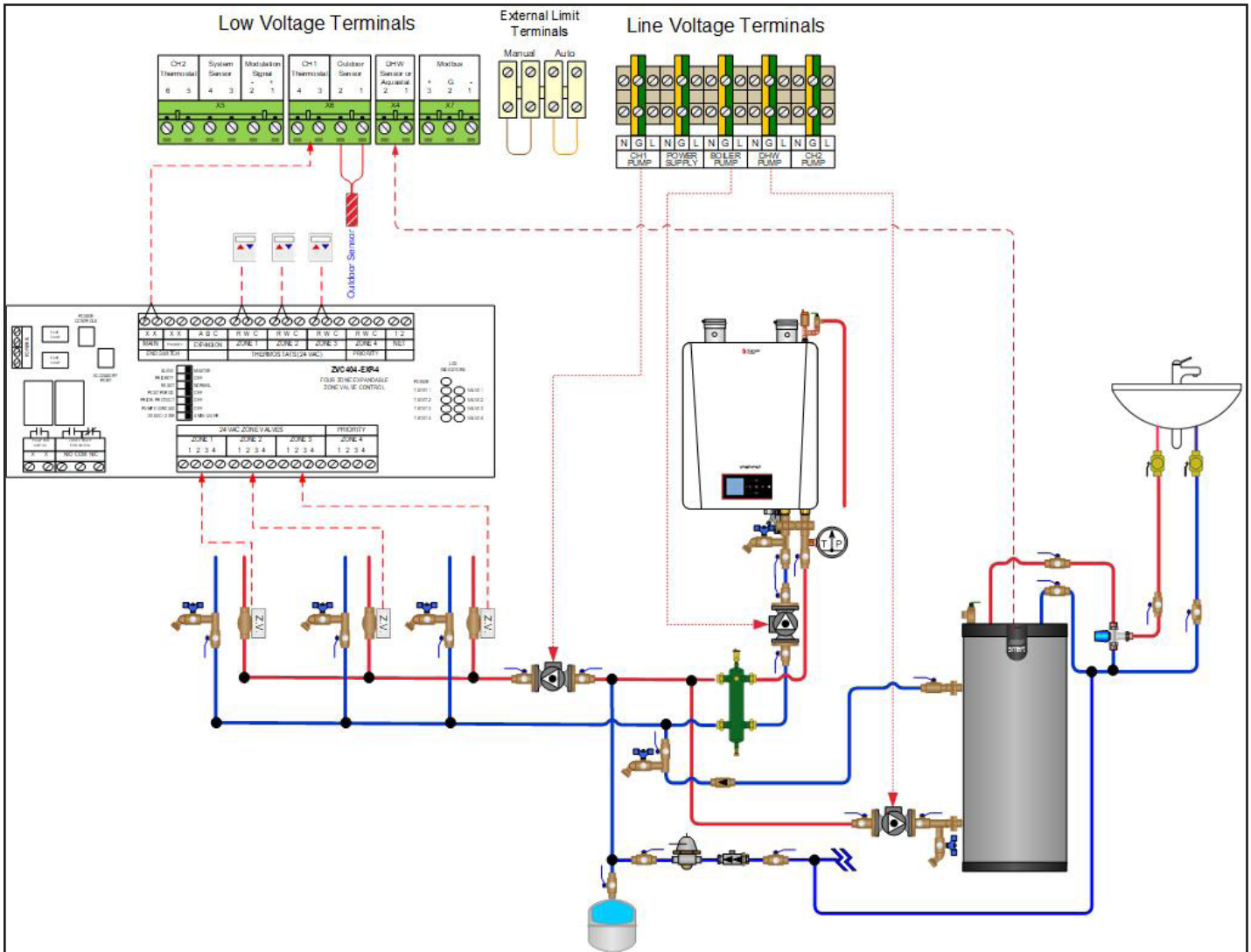

Fig. 24: Instinct Solo - Piping with Zone Valves and Zone Valve Control Panel

NOTICE

Piping layout is shown with a Hydraulic Separator. Closely spaced tees and an air separator can be used as shown in Fig. 18 on page 8.

Preset E Pump Configuration

Heat Call	Boiler Pump	CH1 Pump	CH2 Pump	DHW Pump
CH1	ON	ON	OFF	OFF
CH2	ON	OFF	ON	OFF
DHW	OFF	OFF	OFF	ON

Note: the boiler pump settings must be changed for this arrangement

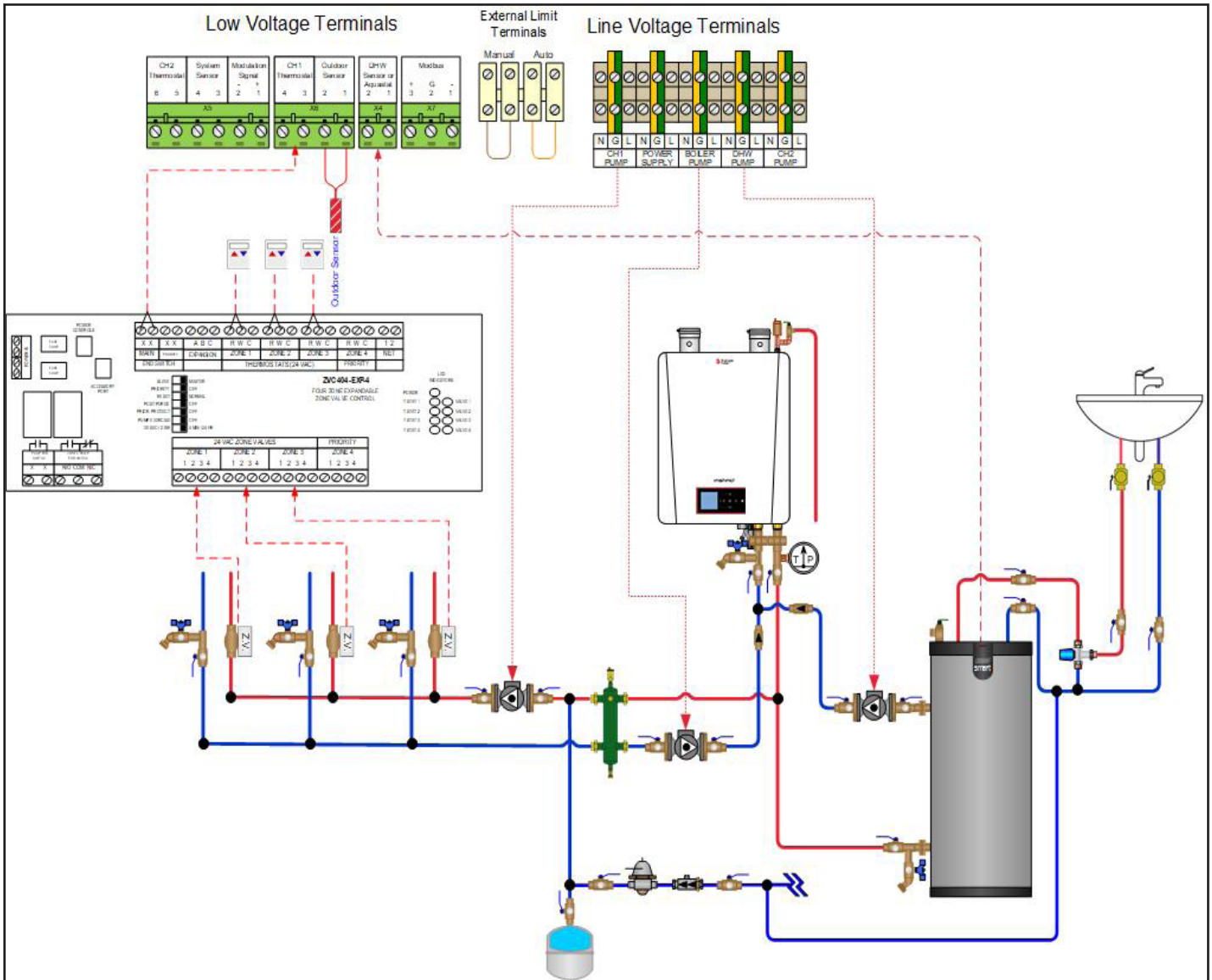

Fig. 25: Instinct Solo - Piping with Zone Valves and Zone Valve Control Panel - Domestic Piping Alternate

NOTICE

Piping layout is shown with a Hydraulic Separator. Closely spaced tees and an air separator can be used as shown in Fig. 18 on page 8.

Preset B Pump Configuration

Heat Call	Boiler Pump	CH1 Pump	CH2 Pump	DHW Pump
CH1	ON	ON	OFF	OFF
CH2	ON	OFF	ON	OFF
DHW	ON	OFF	OFF	ON

Note: the boiler is set up in this configuration out of the box

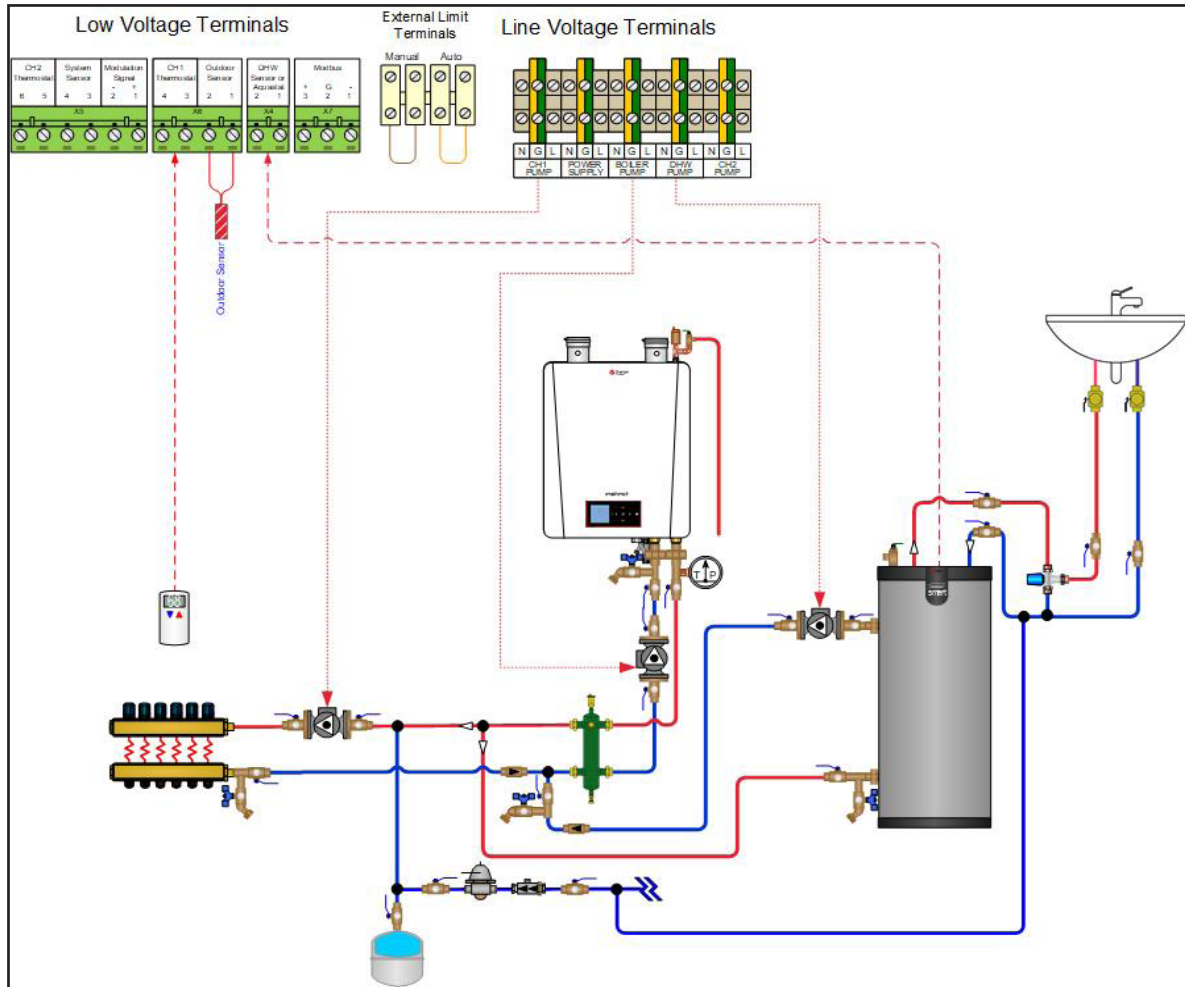

Fig. 26: Instinct Solo - Single Zone with Circulator

NOTICE

Piping layout is shown with a Hydraulic Separator. Closely spaced tees and an air separator can be used as shown in Fig. 18 on page 8.

Layout is shown with separate Circulator and check valve. If using a circulator with internal check valve, the corresponding check valve is unnecessary.

Preset E Pump Configuration

Heat Call	Boiler Pump	CH1 Pump	CH2 Pump	DHW Pump
CH1	ON	ON	OFF	OFF
CH2	ON	OFF	ON	OFF
DHW	OFF	OFF	OFF	ON

Note: the boiler pump settings must be changed for this arrangement

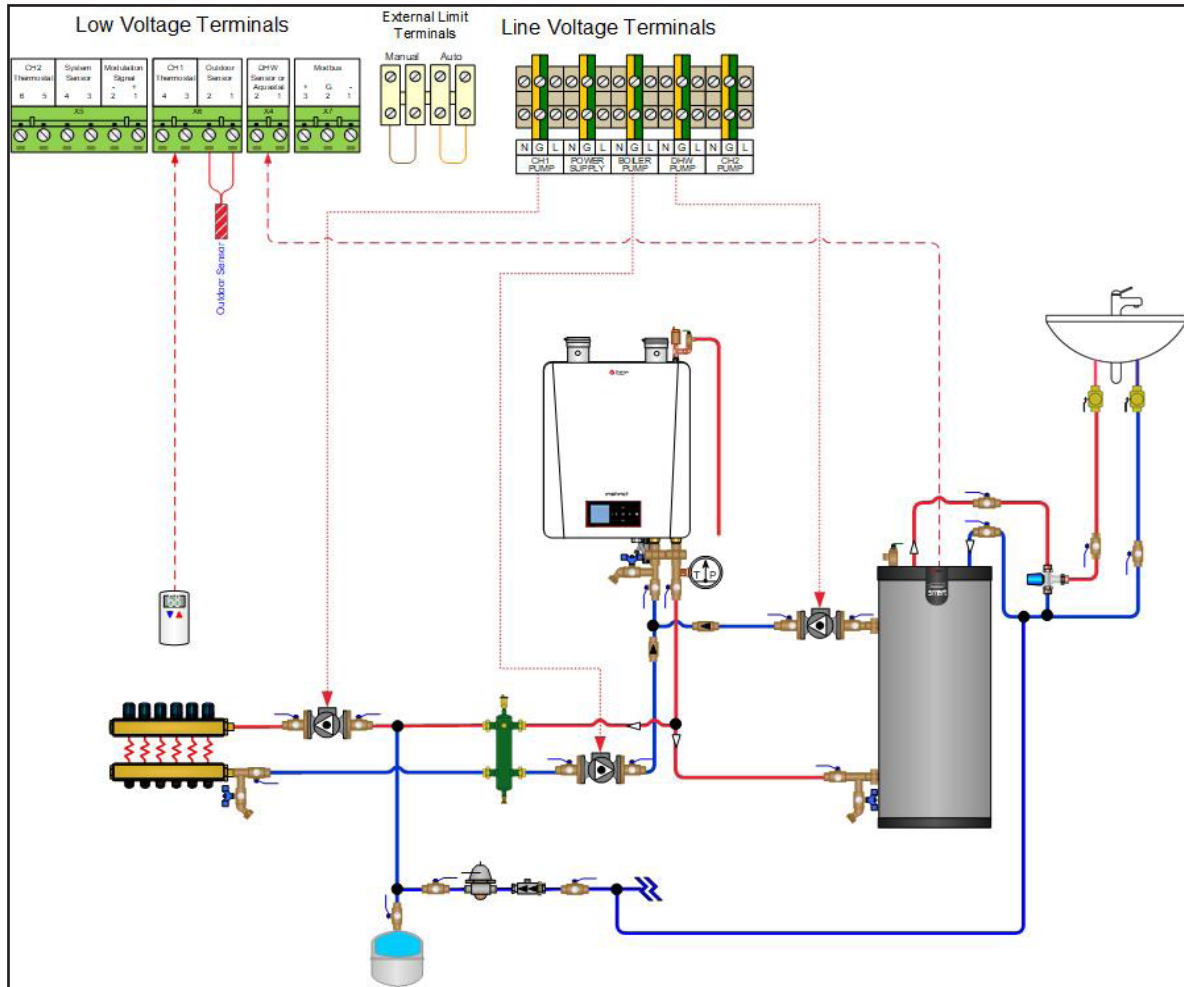

Fig. 27: Instinct Solo - Single Zone with Circulator - Domestic Piping Alternate

NOTICE

Piping layout is shown with a Hydraulic Separator. Closely spaced tees and an air separator can be used as shown in Fig. 18 on page 8.

Layout is shown with separate Circulator and check valve. If using a circulator with internal check valve, the corresponding check valve is unnecessary.

Preset E Pump Configuration

Heat Call	Boiler Pump	CH1 Pump	CH2 Pump	DHW Pump
CH1	ON	ON	OFF	OFF
CH2	ON	OFF	ON	OFF
DHW	OFF	OFF	OFF	ON

Note: the boiler pump settings must be changed for this arrangement

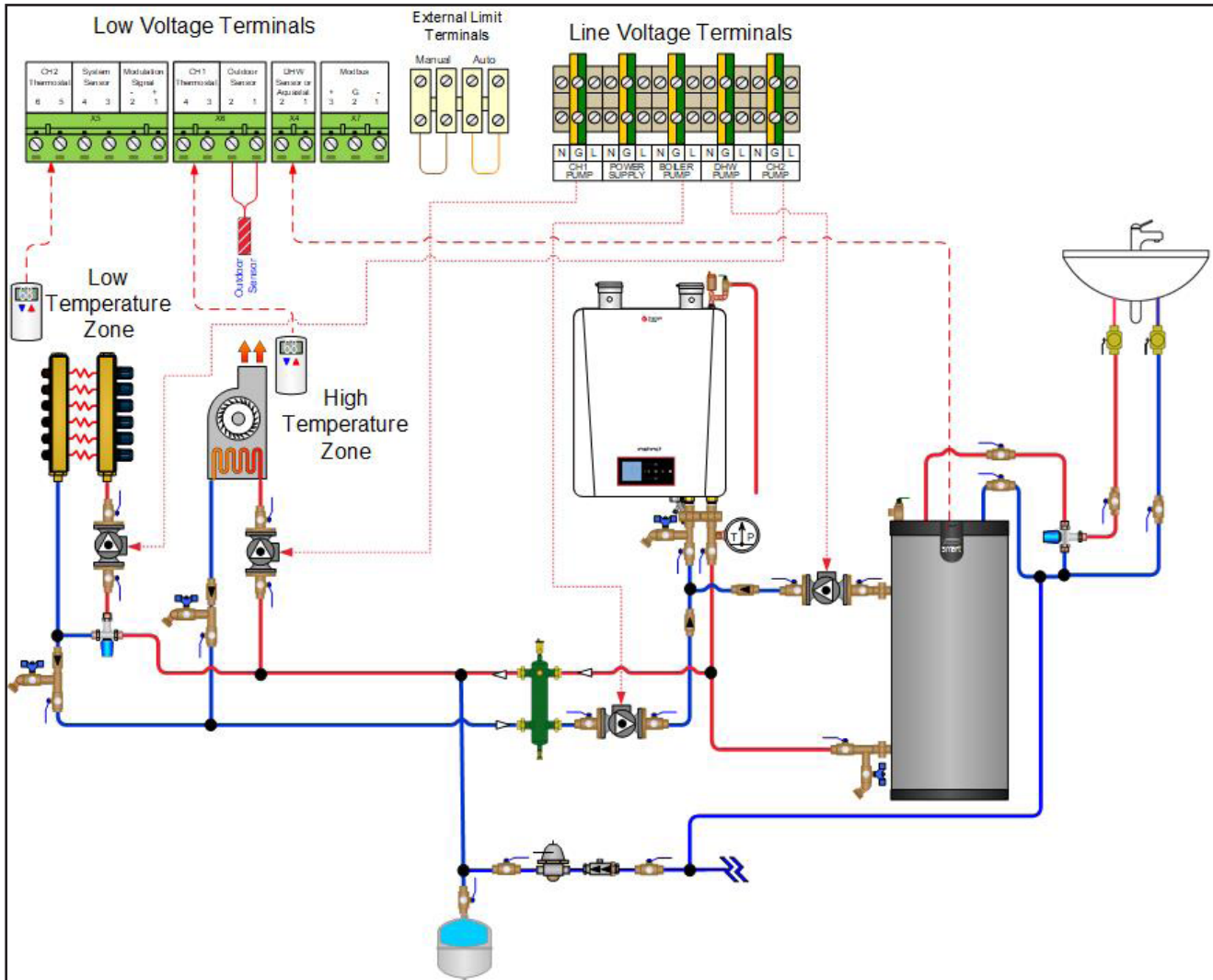

Fig. 28: Instinct Solo - Multiple Temperature Zones with Circulators

NOTICE

Piping layout is shown with a Hydraulic Separator. Closely spaced tees and an air separator can be used as shown in Fig. 18 on page 8.

Layout is shown with separate Circulator and check valve. If using a circulator with internal check valve, the corresponding check valve is unnecessary.

Preset B Pump Configuration

Heat Call	Boiler Pump	CH1 Pump	CH2 Pump	DHW Pump
CH1	ON	ON	OFF	OFF
CH2	ON	OFF	ON	OFF
DHW	ON	OFF	OFF	ON

Note: the boiler is set up in this configuration out of the box

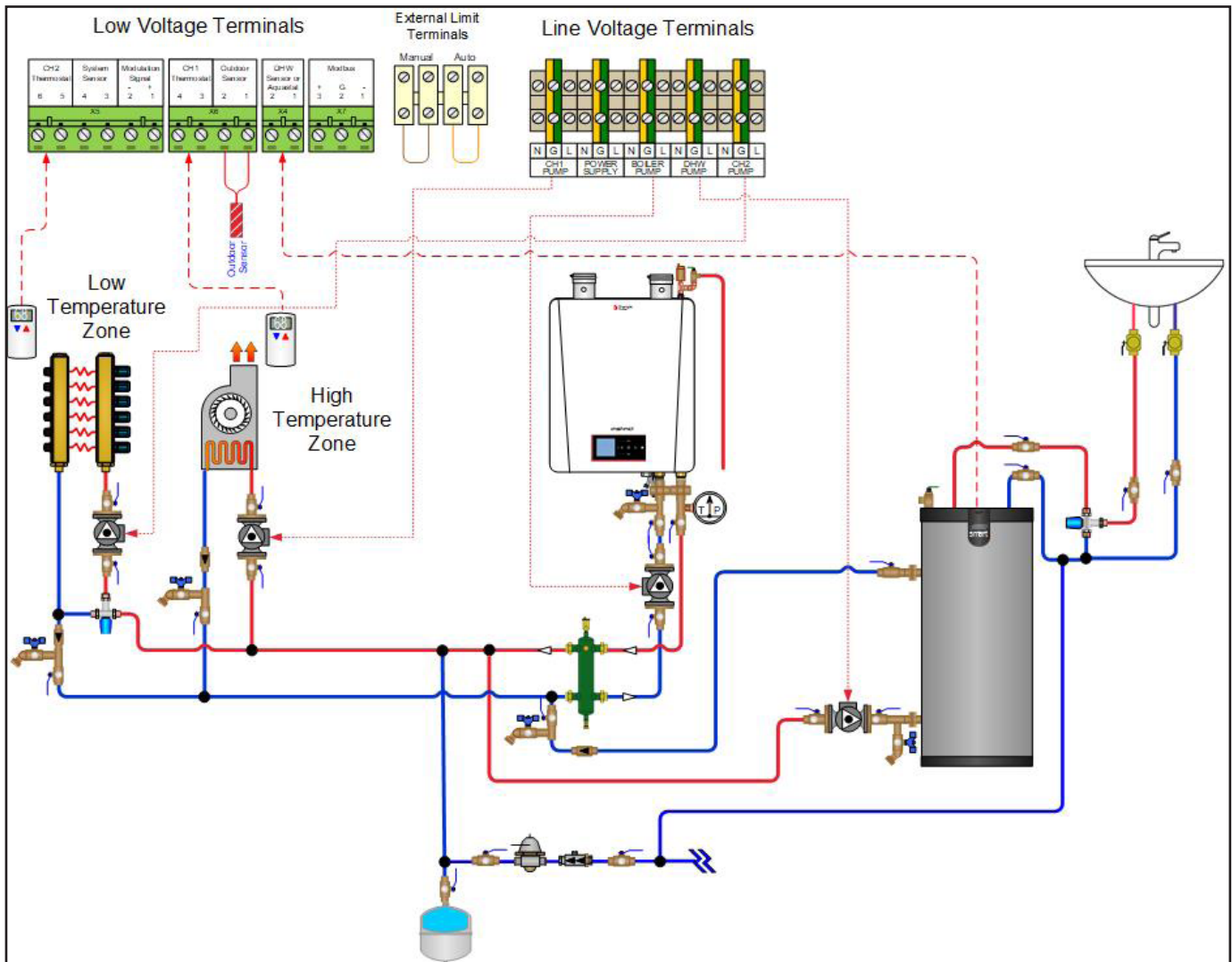

Fig. 29: Instinct Solo - Multiple Temperature Zones with Circulators - Domestic Piping Alternate

NOTICE

Piping layout is shown with a Hydraulic Separator. Closely spaced tees and an air separator can be used as shown in Fig. 18 on page 8.

Layout is shown with separate Circulator and check valve. If using a circulator with internal check valve, the corresponding check valve is unnecessary.

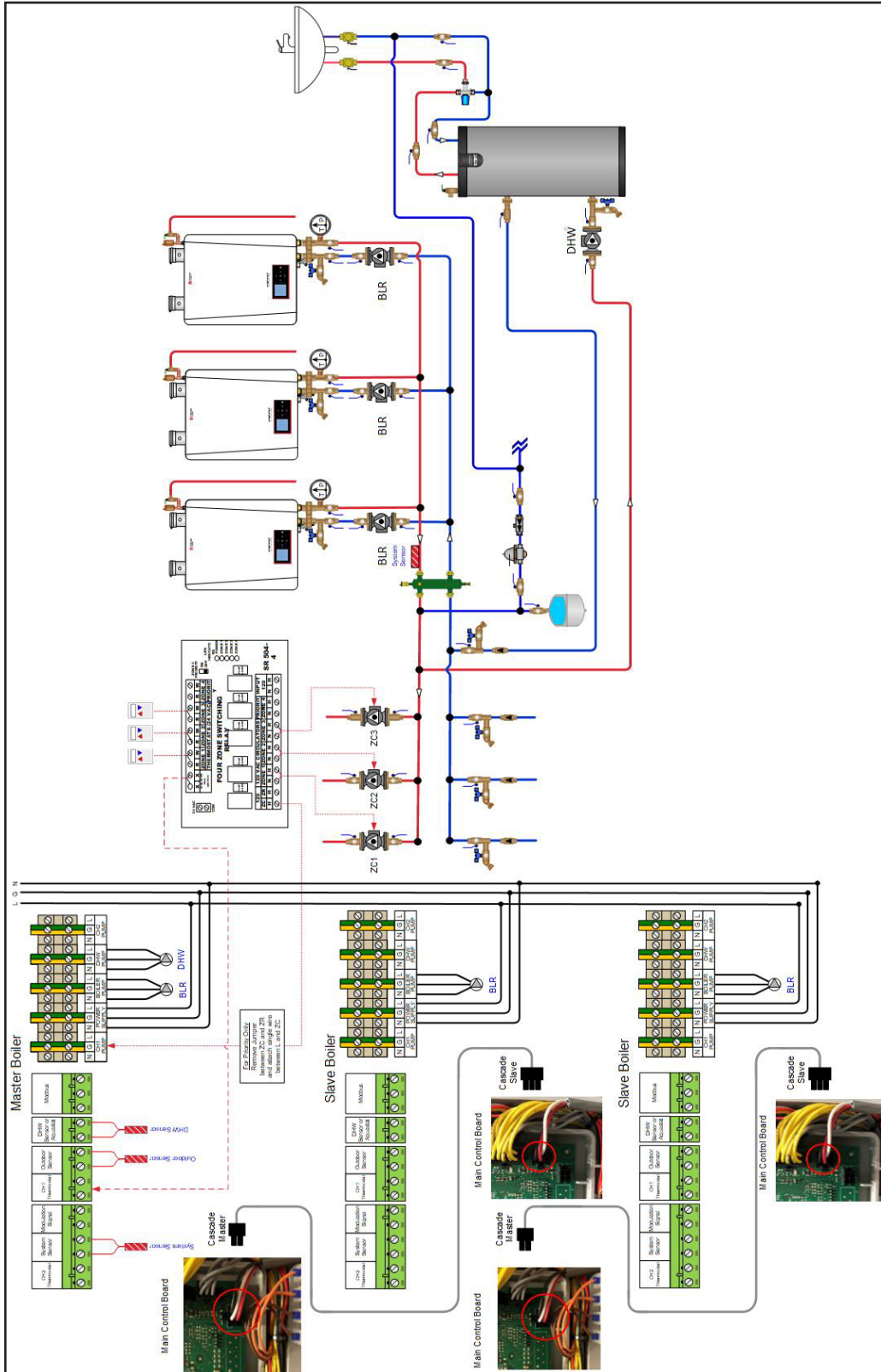

Fig. 30: Instinct Solo - Cascade Layout

5. Instinct Combi Piping Diagrams

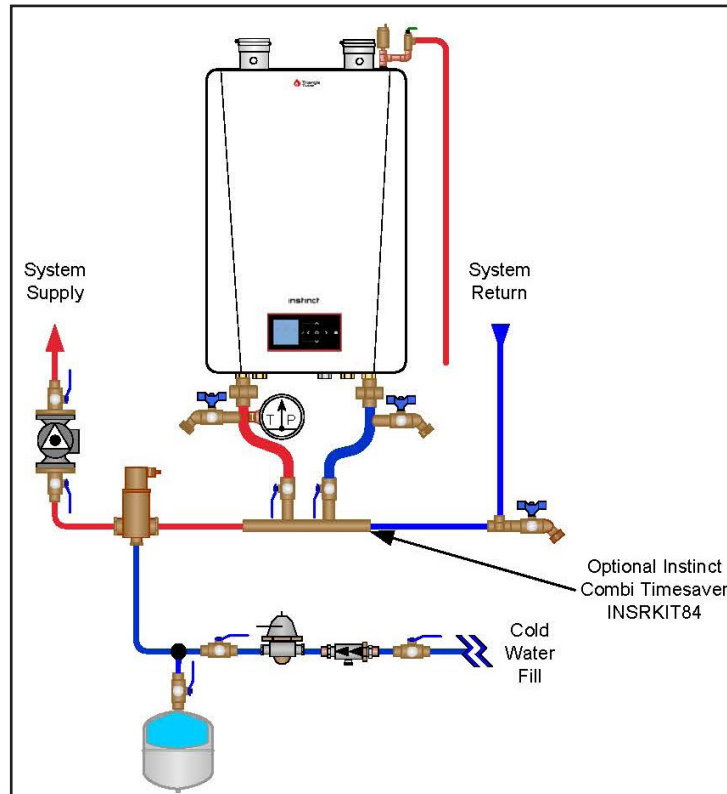

Fig. 31: Instinct Combi Near Boiler Piping with Timesaver Manifold

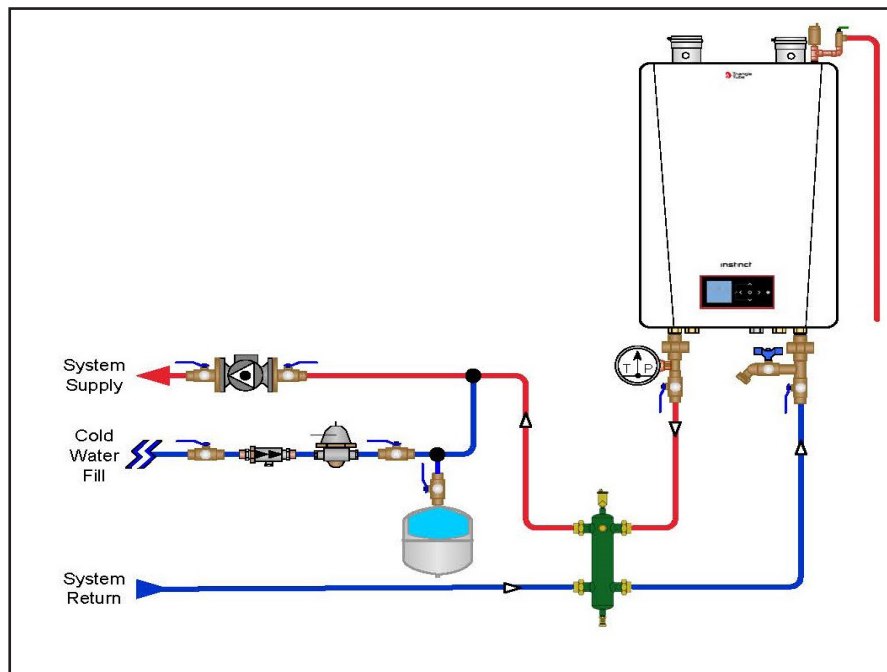

Fig. 32: Instinct Combi Near Boiler Piping with Hydraulic Separator

Preset B Pump Configuration

Heat Call	Boiler Pump	CH1 Pump	CH2 Pump	DHW Pump
CH1	ON	ON	OFF	OFF
CH2	ON	OFF	ON	OFF
DHW	ON	OFF	OFF	ON

Note: the boiler is set up in this configuration out of the box

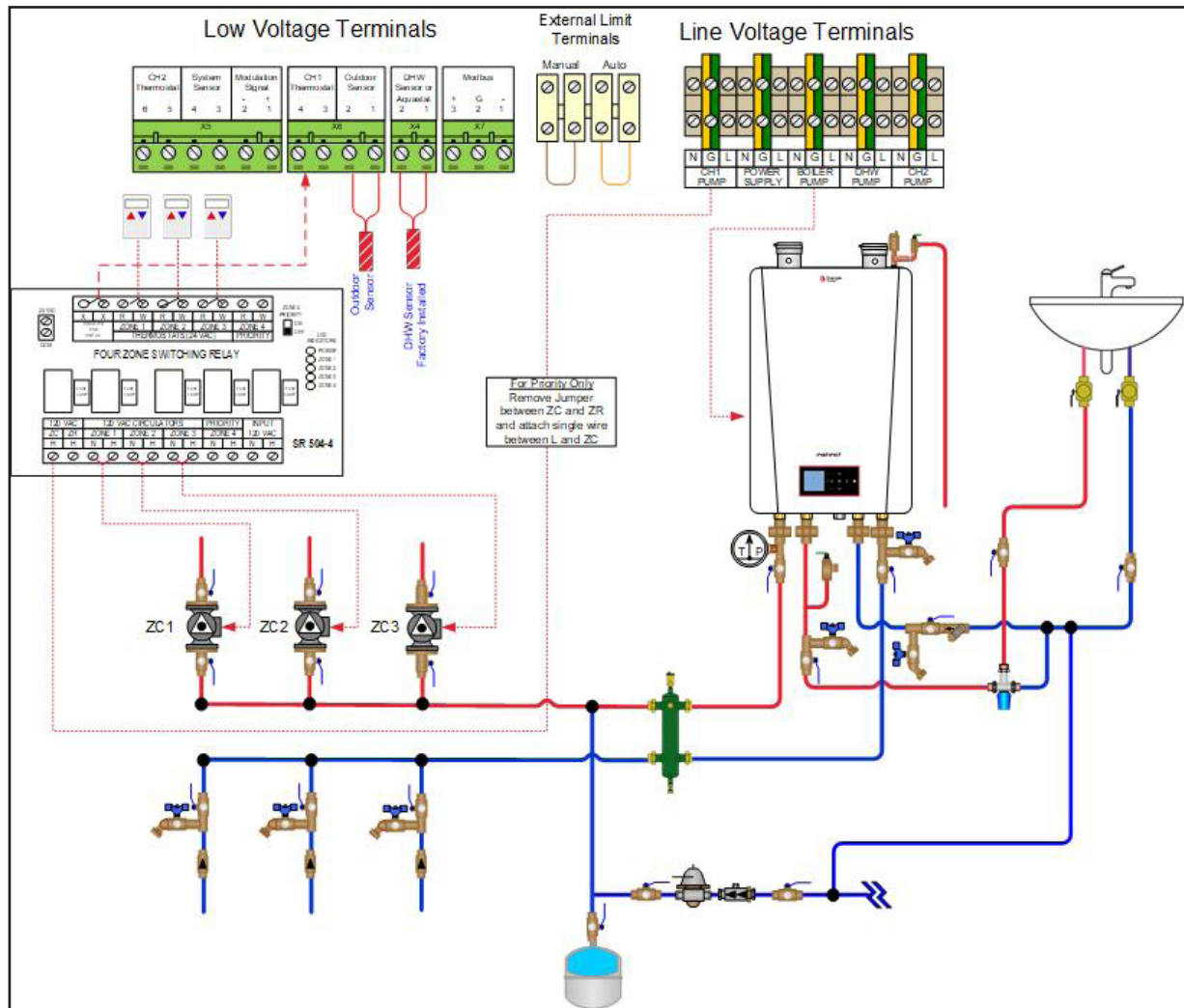

Fig. 33: Instinct Combi - Multiple Zones with Circulators and External Panel

NOTICE

Piping layout is shown with a Hydraulic Separator. The Timesaver manifold (INSRKIT84) and air separator can be used as shown in Fig. 31 on page 20.

Layout is shown with separate Circulator and check valve. If using a circulator with internal check valve, the corresponding check valve is unnecessary.

Preset B Pump Configuration

Heat Call	Boiler Pump	CH1 Pump	CH2 Pump	DHW Pump
CH1	ON	ON	OFF	OFF
CH2	ON	OFF	ON	OFF
DHW	ON	OFF	OFF	ON

Note: the boiler is set up in this configuration out of the box

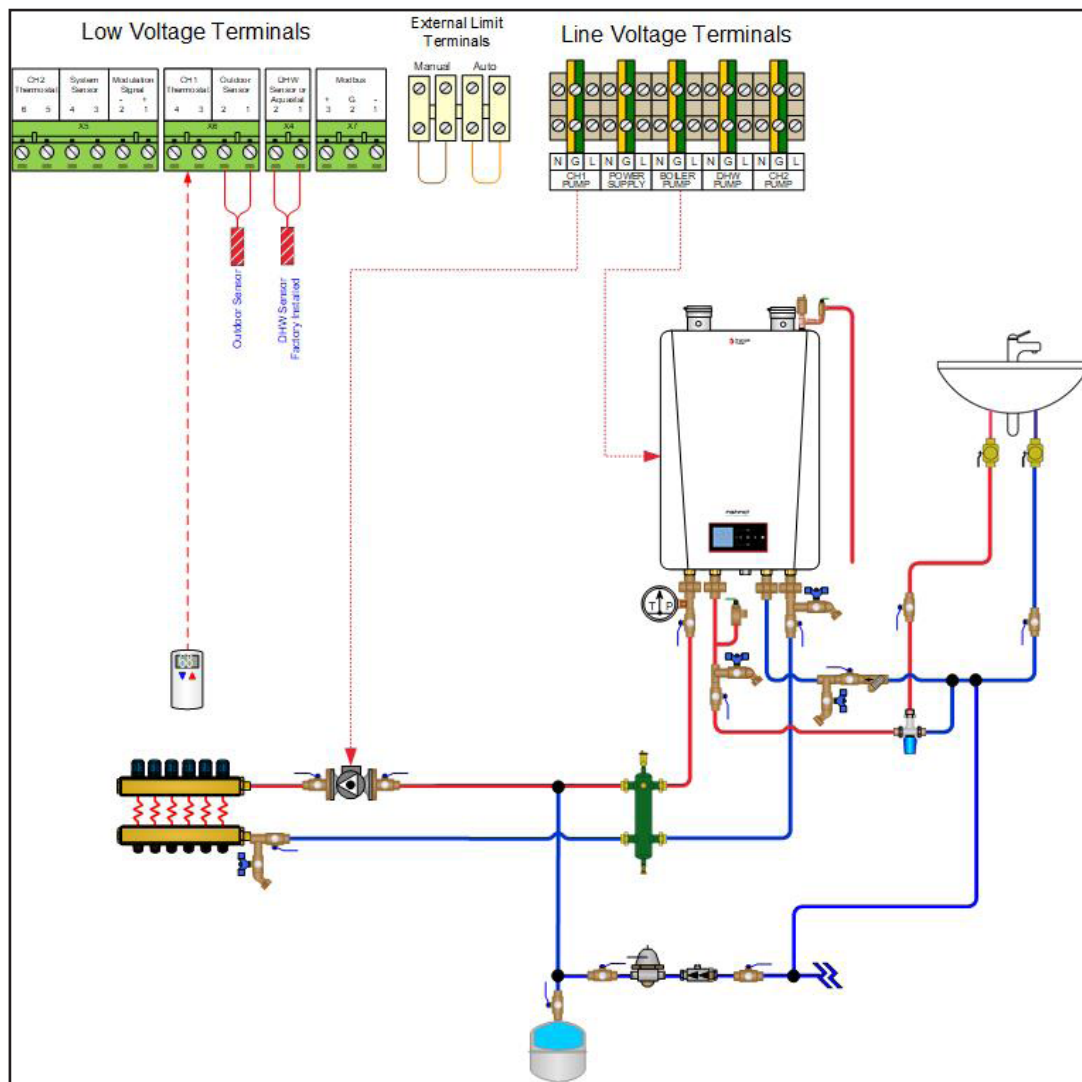

Fig. 34: Instinct Combi - Single Zones with Circulator

NOTICE

Piping layout is shown with a Hydraulic Separator. The Timesaver manifold (INSRKIT84) and air separator can be used as shown in Fig. 31 on page 20.

Layout is shown with separate Circulator and check valve. If using a circulator with internal check valve, the corresponding check valve is unnecessary.

Preset B Pump Configuration

Heat Call	Boiler Pump	CH1 Pump	CH2 Pump	DHW Pump
CH1	ON	ON	OFF	OFF
CH2	ON	OFF	ON	OFF
DHW	ON	OFF	OFF	ON

Note: the boiler is set up in this configuration out of the box

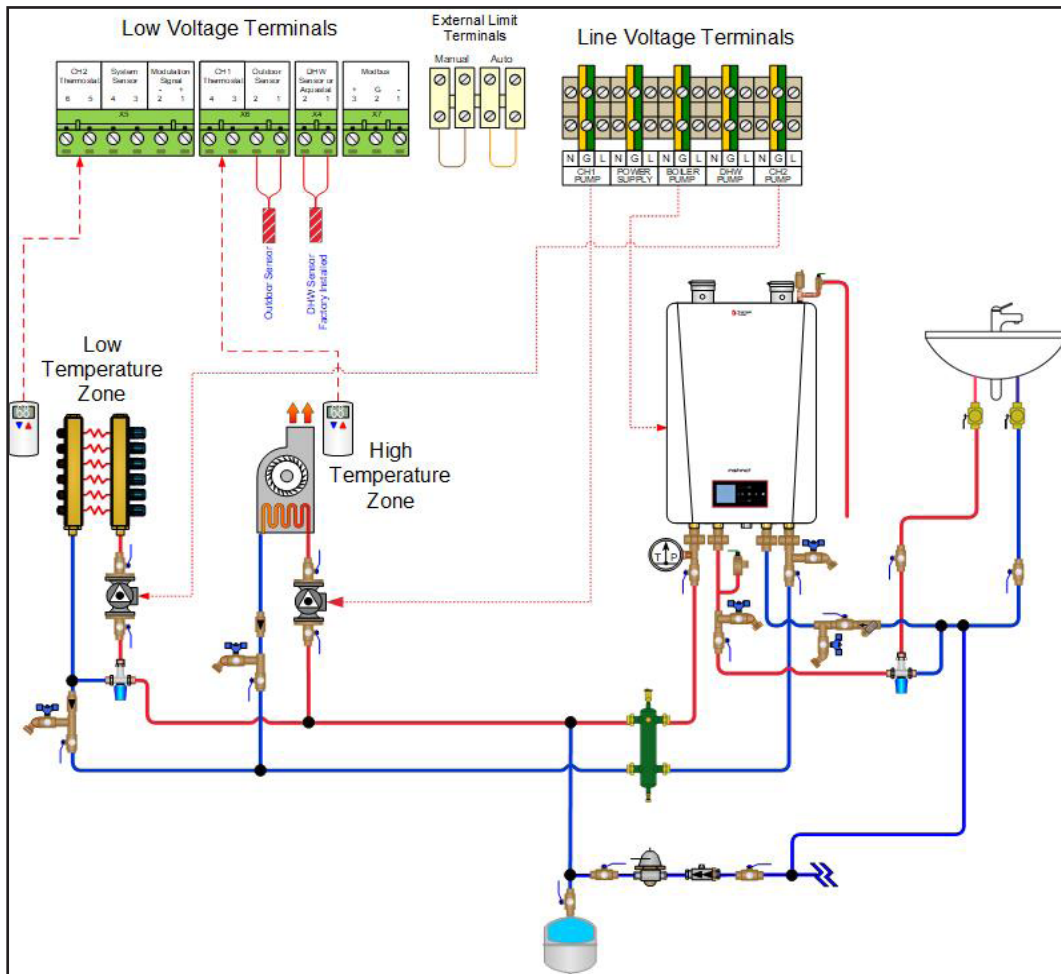

Fig. 35: Instinct Combi - Multiple Temperature Zones with Circulators

NOTICE

Piping layout is shown with a Hydraulic Separator. The Timesaver manifold (INSRKIT84) and air separator can be used as shown in Fig. 31 on page 20.

Layout is shown with separate Circulator and check valve. If using a circulator with internal check valve, the corresponding check valve is unnecessary.

Preset A or D Pump Configuration (D Shown)

Heat Call	Boiler Pump	CH1 Pump	CH2 Pump	DHW Pump
CH1	ON	ON	ON	OFF
CH2	ON	ON	ON	OFF
DHW	ON	OFF	OFF	ON

Note: the boiler pump settings must be changed for this arrangement

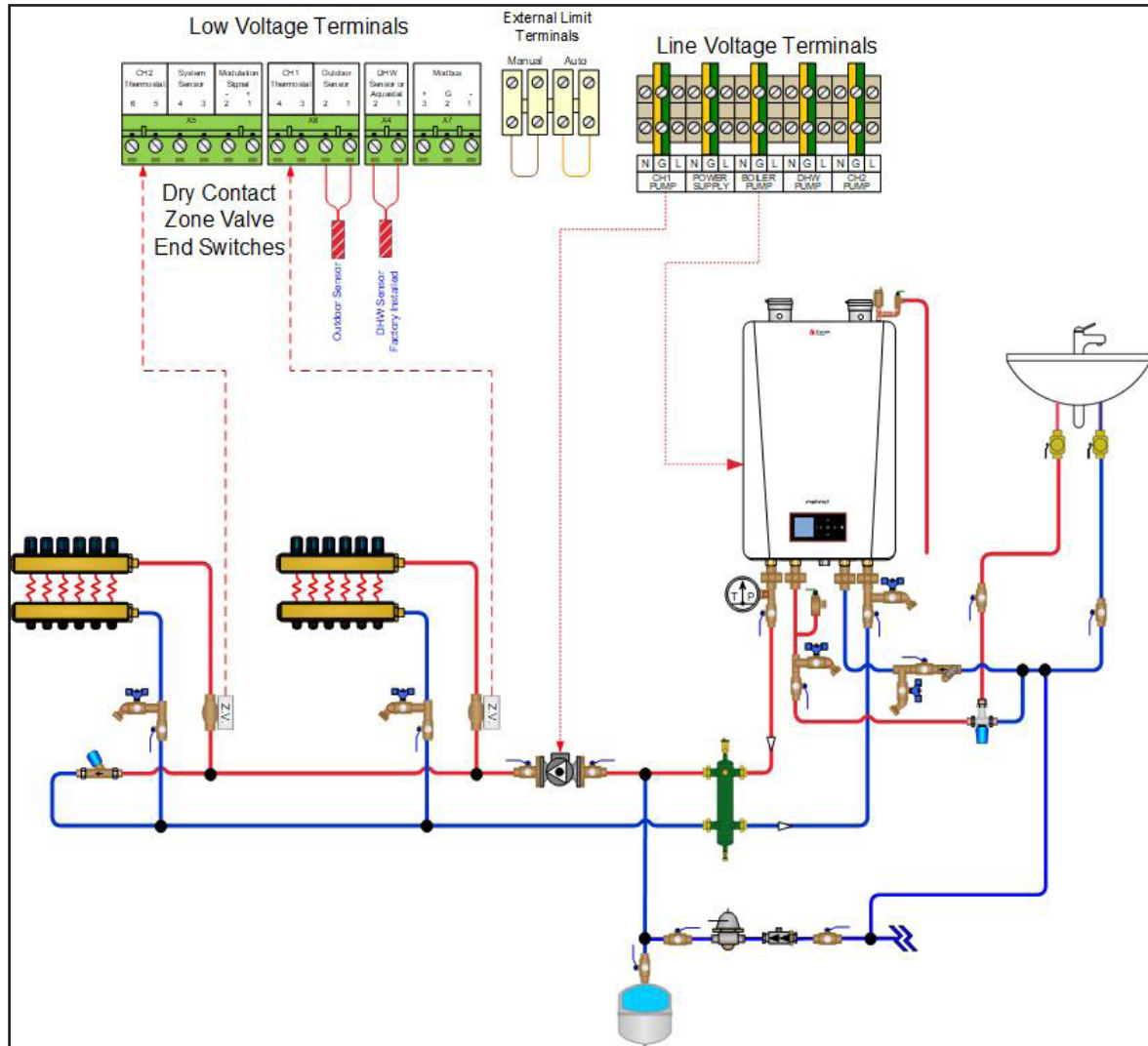

Fig. 36: Instinct Combi - Multiple Zones with Zone Valves

NOTICE

Piping layout is shown with a Hydraulic Separator. The Timesaver manifold (INSRKIT84) and air separator can be used as shown in Fig. 31 on page 20.

Preset B Pump Configuration

Heat Call	Boiler Pump	CH1 Pump	CH2 Pump	DHW Pump
CH1	ON	ON	OFF	OFF
CH2	ON	OFF	ON	OFF
DHW	ON	OFF	OFF	ON

Note: the boiler is set up in this configuration out of the box

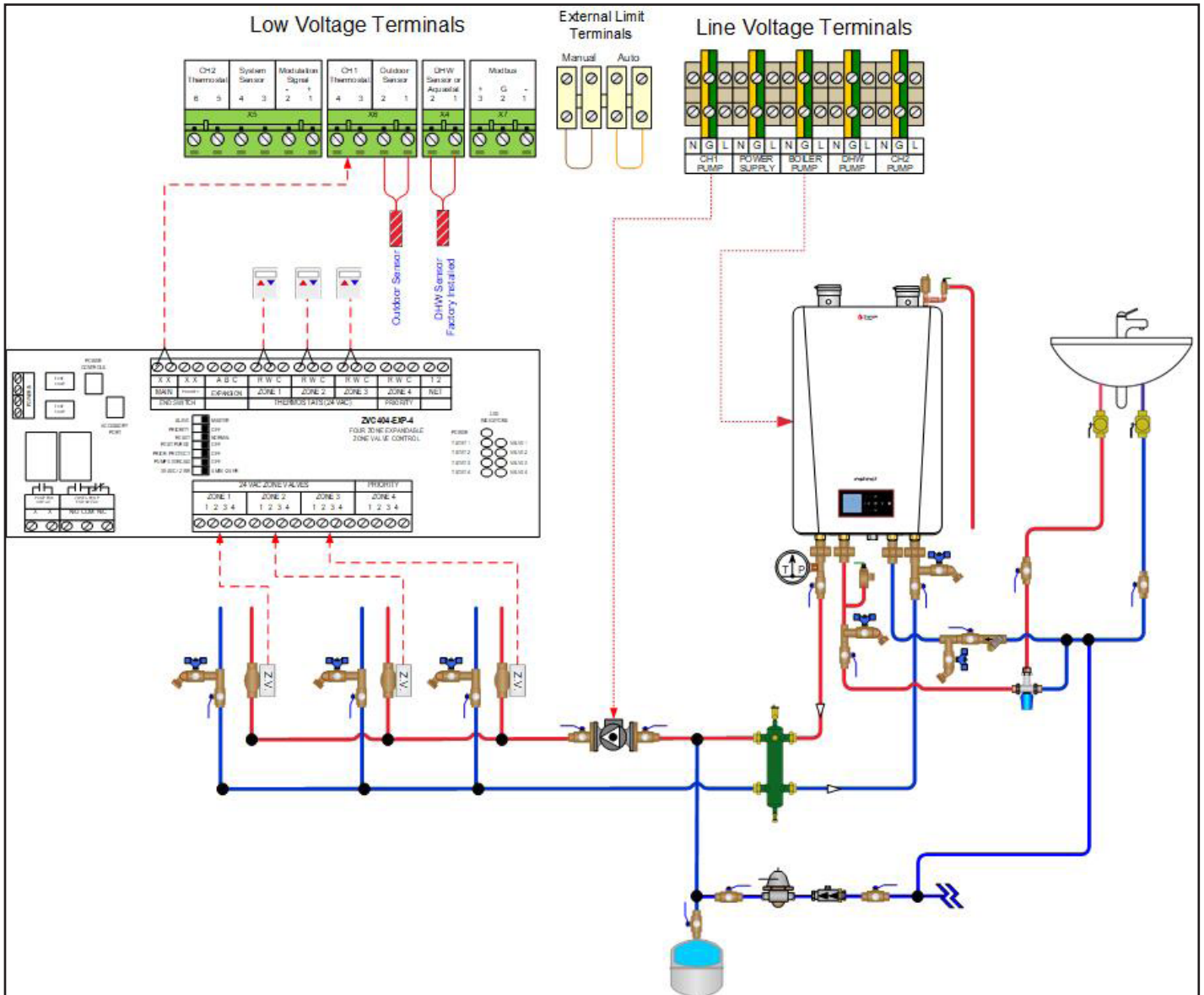

Fig. 37: Instinct Combi - Multiple Zones with Zone Valves and Zone Valve Control Panel

NOTICE

Piping layout is shown with a Hydraulic Separator. The Timesaver manifold (INSRKIT84) and air separator can be used as shown in Fig. 31 on page 20.



Triangle Tube - 1240 Forest Parkway, Suite 100, West Deptford NJ 08066
Tel: (856) 228 8881 - Fax: (856) 228 3584 - E-mail: info@triangletube.com