

PRESTIGE TriMax Blower and Gasket Replacement Kit



- **Kit Part Number:** PTRKIT114
PSRKIT13

Parts List (Fig.1)

- Blower / Motor Housing
- Blower Mounting Gasket
- Venturi Mounting Gasket (not shown)
- (4) M4 x 12 Torxs
- #25 Torx Wrench (not shown)
- (2) M5 x 12 Screws (not shown)

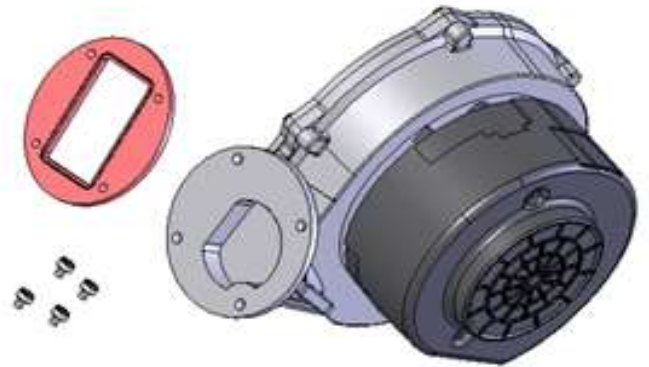

Fig. 1: Blower & Gasket Kit

Recommended Tools:

- Phillips Screwdriver
- Flat Blade Putty Knife
- Extended Phillips Bit



WARNING

Indicates a potentially hazardous situation which, if ignored, can result in serious injury or substantial property damage.



Indicates special instructions on installation, operation or maintenance, which are important to equipment but not related to personal injury hazards.



WARNING

For your safety, turn off electrical power supply at service panel and allow unit to cool before proceeding to avoid possible electrical shock and scald hazard. Failure to do so can cause severe personal injury or death.



WARNING

Failure to follow instructions below can result in severe personal injury or damage if ignored.

- Instructions are for a qualified installer/ service technician only.
- Read all instructions before proceeding.
- Follow instructions in proper order.



WARNING

For your safety, the boiler may be extremely hot. Ensure the boiler has properly cool prior to servicing. Failure to do so can cause severe personal injury.



Part Kit PSRKIT13 is used on the Prestige 175 and 250.
Part Kit PTRKIT114 is used on the Prestige 60, 110 and EXCELLENCE.

PRESTIGE TriMax Blower and Gasket Replacement Kit



1. Instructions

1. Turn power to the unit "OFF".
2. Remove the front jacket panel and the top / rear jacket access panel.
3. Shut off gas supply to the Prestige boiler at the main manual shutoff valve.
4. Disconnect the gas piping at the brass union located near the gas valve inside the boiler enclosure.

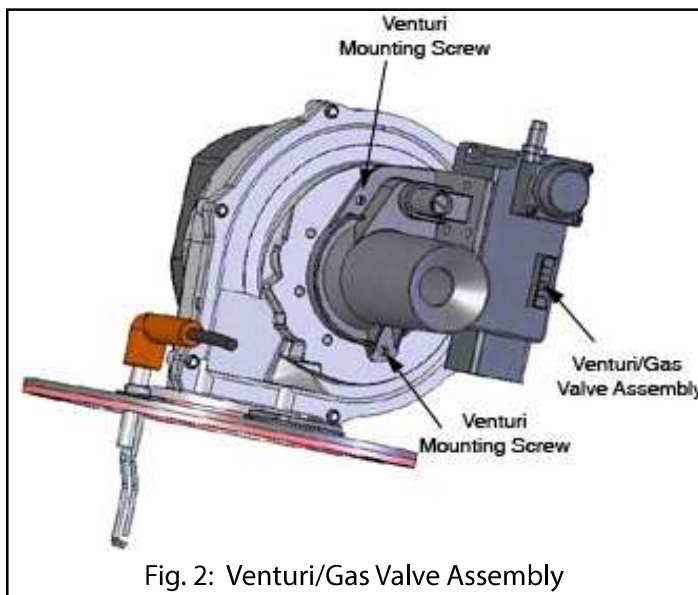

Fig. 2: Venturi/Gas Valve Assembly

5. Remove the Molex or Rectifier plug from the gas valve.
6. Remove the air inlet elbow from the venturi.

NOTICE

Note the orientation of the venturi / gas valve assembly and the venturi gasket in relation to the blower housing when disassembling the venturi / gas valve assembly.

7. Using the #25 Torx wrench from the kit remove the 2 venturi mounting screws from the venturi / gas valve assembly, see Fig. 2. Remove the venturi / gas valve assembly from the blower.

NOTICE

There is a gasket between the venturi and the blower housing. If the gasket "sticks" to the blower housing use a flat blade putty knife to remove any gasket material. Make sure not to scratch or score the mating surface on the blower housing.

8. Disconnect the blower wire harness Molex plug(s) from the blower housing.
9. Using the extended Phillips or Torx bit included in the kit remove the 4 mounting screws securing the blower housing to the burner plate. Do not discard the blower housing.

NOTICE

There is a gasket between the blower housing and the burner plate. If the gasket "sticks" to the burner plate use a flat blade putty knife to remove any gasket material. Make sure not to scratch or score the mating surface on the burner plate.

NOTICE

For the reassembly process do not use adhesives on any gasket surfaces.

10. Install the new blower gasket to the new blower housing and assemble to the burner plate using the (4) M4 x 12 screws included in the kit, see Fig. 3.
11. Attach the Molex plug(s) on the wiring harness to the connector(s) on the blower.

WARNING

The Molex plug will only fit in one direction. Do not force the plug. If the plug does not fit rotate the plug 180°.

NOTICE

On PRESTIGE 60, 110 and EXCELLENCE Boilers with serial numbers beginning with PS, ensure to connect the 120 V wire harness to the blower. The harness is located and wire tied in the upper right corner of the jacket enclosure.

PRESTIGE TriMax Blower and Gasket Replacement Kit

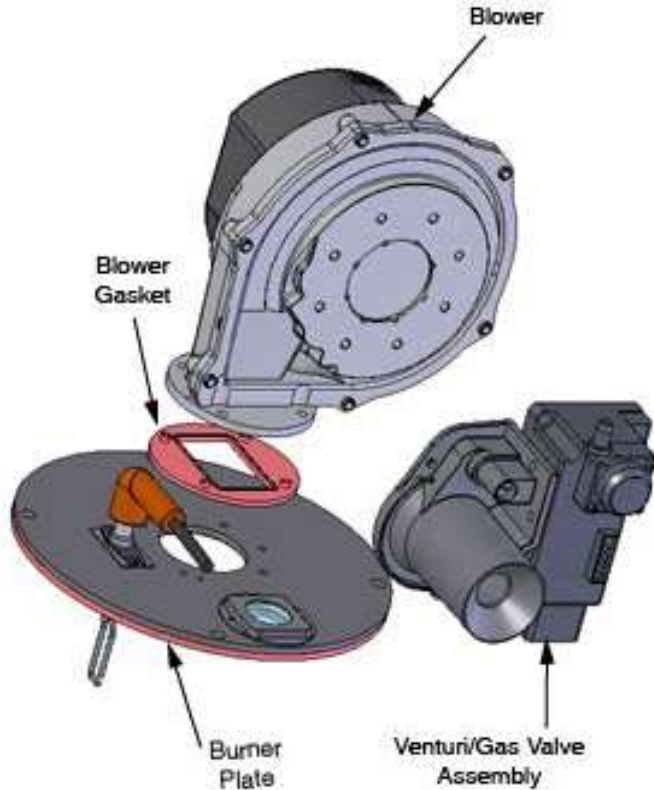

Fig. 3: Venturi/Gas Valve and Blower Assembly

12. Install the venturi gasket on the venturi and reassemble the venturi / gas valve assembly to the blower housing using the (2) M5 x 12 mounting screws supplied in the kit. Use the #25 Torx wrench to tighten all screws and secure the assembly.
13. Reconnect the Molex or Rectifier plug to the gas valve.
14. Reconnect the gas piping at the brass union and tighten.
15. Open the main shutoff valve to the gas supply piping. Before placing the Prestige back into service check and test all gas piping connections for leaks. Repair leaks if found.

16. Reattach the air inlet elbow to the venturi.
17. Remount the front jacket panel and the top / rear jacket access panel to the unit.
18. Turn power supply to the Prestige "ON" and return the unit to service.



Do not check for gas leaks with an open flame. Use a bubble test. Failure to check for gas leaks can cause severe personal injury, death or substantial property damage.