

# Technical submittal

Products: **Wessex ModuMax mk3 WM196-588V**

Project:

Customer:

Date:

- ⊗ Stainless steel heat exchanger
- ⊗ 15:1 turndown ratio
- ⊗ Capable of 40°C differential temperature
- ⊗ Operates up to 90°C maximum flow temperature
- ⊗ 10 bar rated heat cell
- ⊗ 10-year heat exchanger warranty
- ⊗ 93.9% gross seasonal efficiency
- ⊗ 574.8kW output @80/60°C
- ⊗ Fits in a footprint of 680 x 1082mm
- ⊗ Passes through a standard doorway
- ⊗ 39.9 mg/kWh NOx emissions (natural gas)
- ⊗ Noise on minimum modulation of less than 47dba
- ⊗ Built-in controls platform with sequence control and capable of controlling up to 16 boiler modules and hot water circuits
- ⊗ British manufactured



	Wessex ModuMax mk3 boiler model	Units	196/588V
	No. of modules		3
Energy	Building regulations Part L seasonal efficiency	% gross	93.9
	BS EN 15502 seasonal efficiency	% gross	94.1
	Boiler output 80/60°C, NG & LPG	kW	574.8
	Boiler output 50/30°C, NG & LPG	kW	588.9
	Boiler input (gross) - maximum, NG	kW	657
	Boiler input (gross) - maximum, LPG	kW	643.1
	Boiler input (nett) - maximum, NG & LPG	kW	591.6
	Boiler output - minimum 80/60°C, NG & LPG	kW	38.6
Water	Water content	litres	66
	System design flow rate @ 40°C ΔT rise	l/s	3.6
	Water side pressure loss @ 40°C ΔT rise	mbar	62
	System design flow rate @ 30°C ΔT rise	l/s	4.8
	Water side pressure loss @ 30°C ΔT rise	mbar	120
	System design flow rate @ 20°C ΔT rise	l/s	7.2
	Water side pressure loss @ 20°C ΔT rise	mbar	246
	System design flow rate @ 11°C ΔT rise	l/s	12.9
	Water side pressure loss @ 11°C ΔT rise	mbar	850
	Minimum water pressure	barg	
	Maximum water pressure	barg	10
	Maximum flow temperature setting	°C	90
Gas	Gas flow rate, NG (G20) - maximum	m³/hr	62.7
	Gas flow rate, LPG (G31) - maximum	m³/hr	24.3
	Nominal inlet pressure, NG (LPG) - maximum	mbar	20 (37)
	Maximum gas inlet pressure NG (LPG)	mbar	25 (45)
Flue	Approx. flue gas volume @ 15°C, 8.75-9.25% CO <sub>2</sub>	m³/hr	837
	Maximum flue gas temperature @ 80/60°C	°C	83
	Pressure at boiler flue connection	Pa mbar	150 1.5
	Dry NOx emission (0% excess oxygen, dry air free) - NG	mg/kWh	39.9
	Dry NOx emission (0% excess oxygen, dry air free) - LPG	mg/kWh	68.6
Connection	Water flow/return connections	inches	G2½" male
	Gas inlet connection pipe thread size	inches	R1¼" male
	Nominal flue diameter (I/D)	mm	250
	Condensate trap connection(s) (O/D)	mm	32
Electrics	Electrical supply		230V 1Ph 50Hz
	Power consumption - maximum boiler modulation	W	720
	Start current (per module)	Amp	1.3
	Run current (per module)	Amp	1.05
	Approx shipping weight	kg	678
	Noise emission @1m @maximum modulation	Max dB (A)	65
	Noise emission @1m @minimum modulation	Min dB (A)	47

\*Dependent on ΔT - see full brochure

Every effort has been taken to ensure the details are accurate. Hamworthy Heating does not, however, guarantee the accuracy or completeness of any information nor does it accept liability for any errors or omissions in the information. Hamworthy Heating reserves the right to make changes and improvements which may necessitate alteration to product specification without prior notice.



# Technical submittal

Products: **Wessex ModuMax mk3 WM196-588V**

Project:

Customer:

Date:

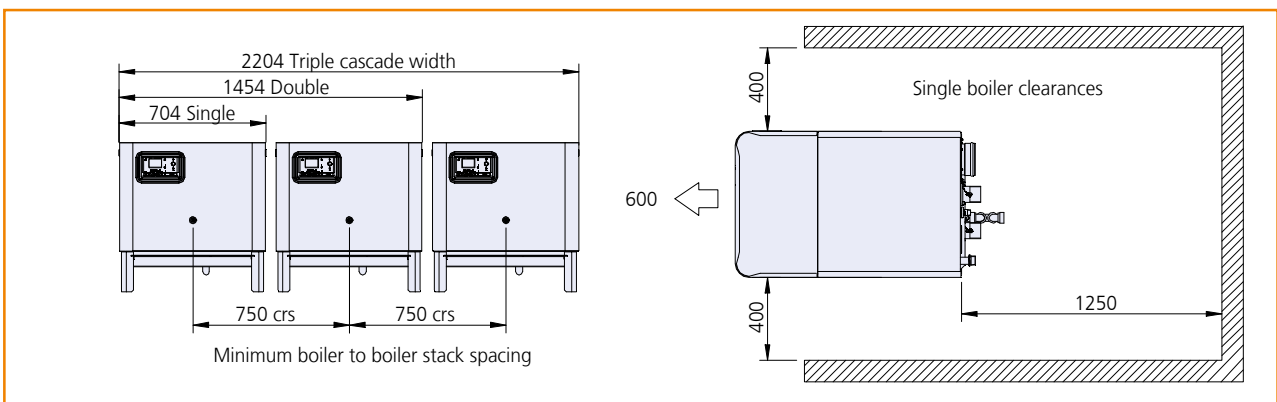
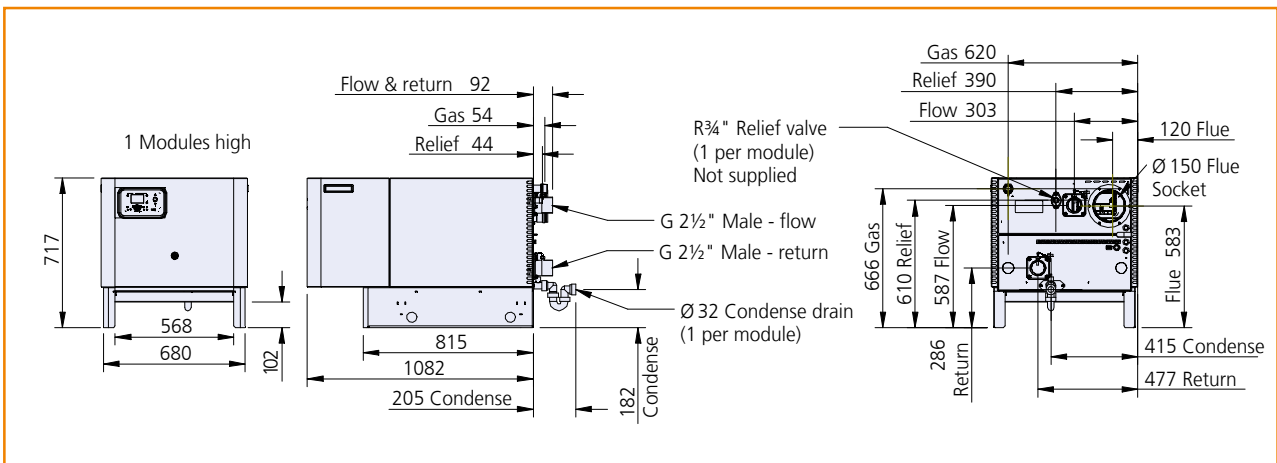
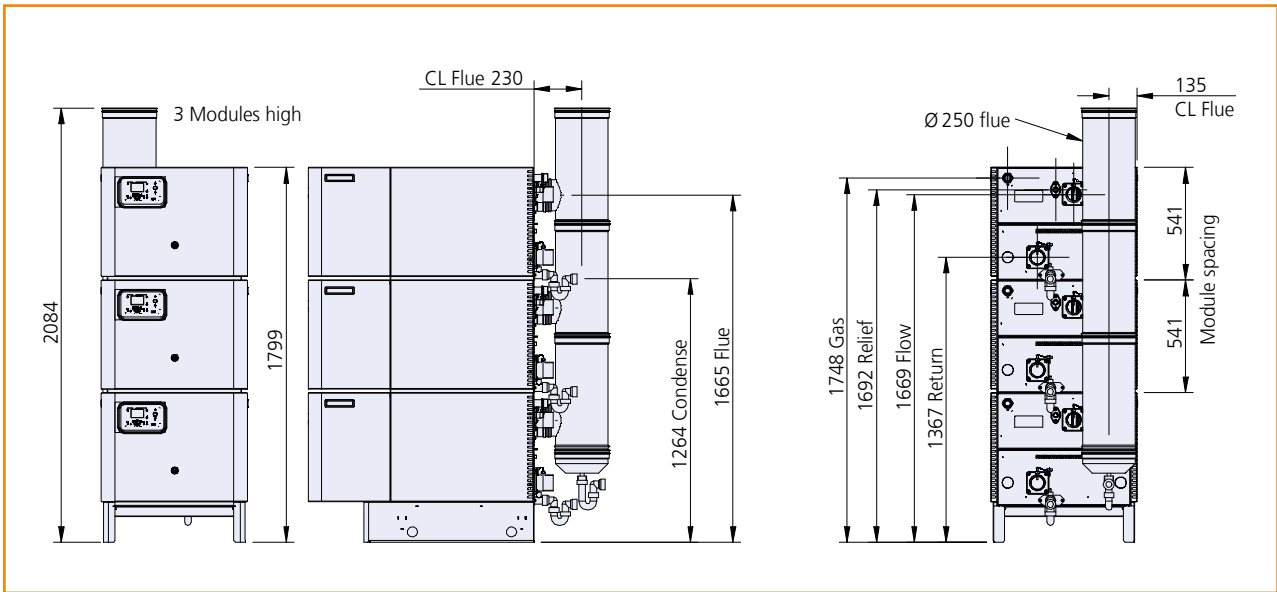

Every effort has been taken to ensure the details are accurate. Hamworthy Heating does not, however, guarantee the accuracy or completeness of any information nor does it accept liability for any errors or omissions in the information. Hamworthy Heating reserves the right to make changes and improvements which may necessitate alteration to product specification without prior notice.