

Commodore Submittal Sheet
Model
WH 1250F
WH 2000F

Commodore Water Tube Floor Standing Commercial Water Heaters

Job Name:

Date:

Location:

Model No.:

Engineer:

Gas Type:

Wholesaler:

Contractor:

WH 1250 Dimensions

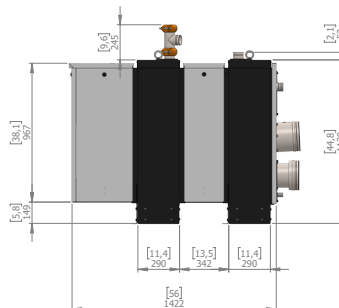
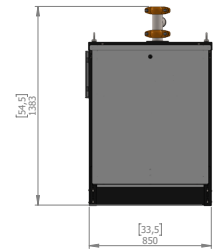
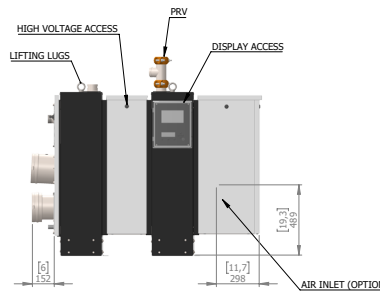
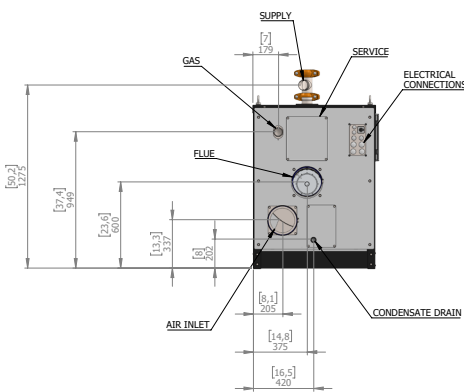
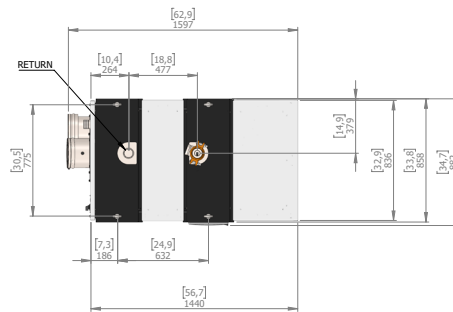

WH 2000 Dimensions

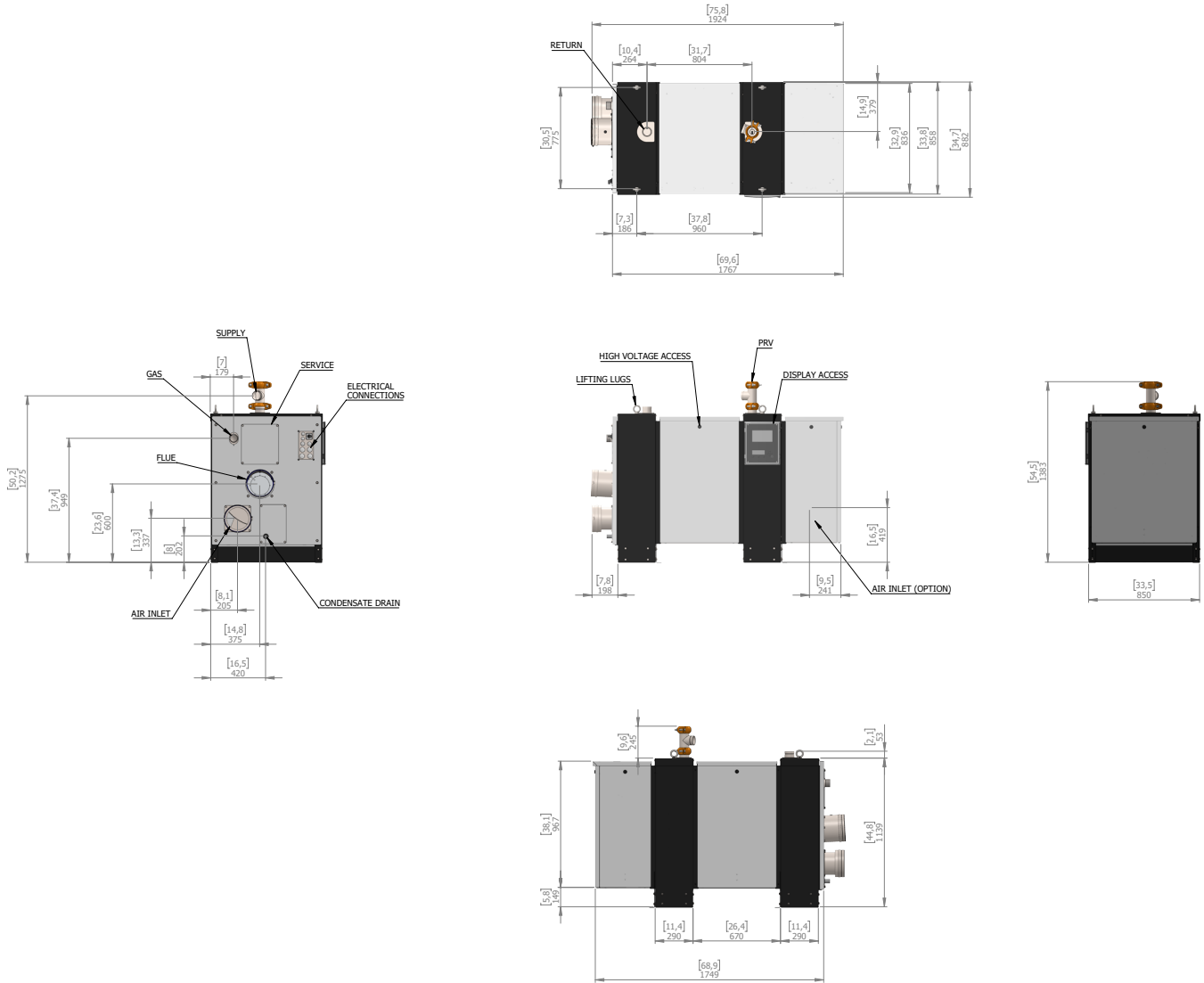

Dimensions and Specifications

Product Selection	Model Number	S/R Water Vic. Conn.	Gas Conn. NPT	Flue Conn. Vent/Air	Vent Length	Height	Width	Depth	Weight lbs
	WH 1250F	2-1/2"	2"	8"/8"	150'	47"	55"	34"	992
	WH 2000F	2-1/2"	2"	8"/8"	115'	47"	68"	34"	1213

Commodore Water Tube Commercial Water Heater Performance Data

Product Selection	Model Number	Input Rate, MBH	Standby Loss, MBH	Input Minimum, MBH	Maximum Supply Temp., F	Thermal Efficiency, %	GPH 100F Rise
	WH 1250F	1250	1.9	156	185	99.0%	1486
	WH 2000F	2000	2.67	236	185	99.0%	2377

Standard Features and Equipment

- ✓ Field convertible
- ✓ LCD display with easy to use controls
- ✓ On/Off Power Switch
- ✓ Laptop computer connection
- ✓ Supply and Return water temperature sensors
- ✓ Integrated pressure sensor
- ✓ Flue gas temperature sensor
- ✓ Burner door temperature clixon
- ✓ Up to 99.0% thermal efficiency
- ✓ Full stainless steel heat exchanger
- ✓ Premix burner
- ✓ Internal automatic air vent with drain connection
- ✓ Outdoor model (NEMA 4)
- ✓ Condensate trap
- ✓ External ignition transformer connection



Boiler and External Controls

- ✓ 7-inch graphical colored touchscreen
- ✓ Large backlit LCD with full text information programming and errors
- ✓ Modbus connection standard
- ✓ 0-10 VDC remote flow temperature set point control
- ✓ 0-10 VDC remote boiler power output
- ✓ Bacnet module for remote access available

Data Logging

- ✓ Real time and date clock
- ✓ Days of operation
- ✓ Successful ignition attempts
- ✓ Ignition failures
- ✓ Flame failures
- ✓ Up to 48 readable lockout errors
- ✓ Hours since last service
- ✓ Hours until next service
- ✓ Total days of boiler operation

Low Voltage Connections

- ✓ Outdoor temperature sensor
- ✓ System temperature sensor
- ✓ DHW temperature sensor
- ✓ Modbus
- ✓ Cascade connection
- ✓ On/Off thermostat or OpenTherm
- ✓ 0-10V VDC input
- ✓ Flow switch DHW
- ✓ PWM pump control
- ✓ External low water cut off
- ✓ Gas pressure switch
- ✓ Universal safety contact set 1 & 2

High Voltage Connections

- ✓ Boiler pump
- ✓ System pump
- ✓ DHW pump
- ✓ DHW twv (3-way valve)
- ✓ Alarm

Additional Features

- ✓ Two level frost protection
- ✓ Short cycle protection
- ✓ Adjustable minimum & maximum power
- ✓ Temperature boost function
- ✓ Multiple levels of security
- ✓ PWM control for variable speed pumps
- ✓ Domestic hot water priority time control
- ✓ Selectable priority for domestic hot water or heating

Cascade

- ✓ Integrated cascade control
- ✓ Cascade control of up to 16 boilers
- ✓ Remote operation and heat demand indication from each boiler
- ✓ Four cascade power program modes
- ✓ Boiler sequencing and rotation control
- ✓ Following boilers fully operational on failure of lead boiler

Accessories

	External flow temperature sensor
	Indirect tank temperature sensor
	PC software+interface cable for programming boiler
	BACNET module
	0-10V Modulating circulator signal converter
	Low water cutoff
	Fixed speed high efficiency circulator
	Fixed speed standard efficiency circulator
	Variable speed high efficiency circulator
	75 psi relief valve (3/4" & 1" & 1-1/4" & 1-1/2")
	100 psi relief valve (3/4" & 1" & 1-1/4")
	125 psi relief valve (3/4" & 1" & 1-1/4")
	150 psi relief valve (3/4" & 1" & 1-1/4")
	8"/10"/12" Motorized Flue Damper
	Neutralizer 400MBH - 7000MBH

