

Cascade Multiple Boiler Distribution Manifold and Hydronic Junction for PRESTIGE Solo 250 or PRESTIGE Solo 399 Boilers

WARNING

This document is intended to be used by a qualified heating contractor or service technician. Read all instructions within this document, the PRESTIGE Boiler Installation and Maintenance Manual and Prestige Vent Supplement before proceeding with the installation. It is recommended to follow the procedures in the steps given, skipping or missing procedural steps could result in severe personal injury, death or substantial property damage.

NOTICE

Installation of boilers must comply with local requirements and codes and with the National Fuel Gas Code NFPA 54, ANSI Z223.1 for installations within the U.S. For installations in Canada the installation must comply with CAN/CSA B149.1.

PRODUCT & SAFETY INFORMATION

Definitions 1
 Product and Safety Information 1

SECTION I – PRE-INSTALLATION ITEMS

Code Compliance..... 2
 Determine Location 2
 Recommended Clearances..... 2
 Cascade Kit Components..... 2
 Operating Restrictions 2
 Kit Component Diagrams and Tables 3-19

SECTION II – COMBUSTION AIR AND VENTING

Combustion Air and Venting 20-21

SECTION III – INSTALLATION

Distribution Manifold 22
 Multiple Distribution Manifolds 22
 Hydronic Junction 23
 Insulation 23
 Boiler Mounting 24

SECTION IV – BOILER PIPING

General..... 25

SECTION V – CSD-1 PIPING & CONTROL INSTALLATION

P/S or R/R with Valves Kit - PSCAS17 26
 Reverse Return (R/R) 26

SECTION VI – SYSTEM PIPING

Multiple Distribution Manifolds 27
 System Piping 27-28
 High Pressure Systems or Involving Fluid Separation 29
 System Piping Diagrams 30-35

SECTION VII – GAS PIPING

Natural Gas Pipe Sizing 36
 Propane Gas Pipe Sizing 36

SECTION VIII – WIRING

Power Supply 37
Multiple Boiler Control 37
CSD-1 P/S or R/R with Valves Kit 37
CSD-1 R/R 37
Field Wiring Diagrams 38-40

SECTION IX – SYSTEM START-UP

Check System Water Chemistry 41
Water pH Level 6.0 to 8.0 41
Water Hardness Less Than 7 Grains 41
Chlorinated Water 41
Flush System to Remove Sediment 41
Use of Antifreeze in the System 41
Check and Test Antifreeze 42

SECTION X – MAINTENANCE SCHEDULE

Service Technician – General 43
Owner Maintenance 43

SECTION XI – MAINTENANCE PROCEDURES

Maintenance Procedures 44
Reported Problems 44
Check Surrounding Area 44
Check System Piping 44
Check Boiler/Cascade System 44
Check Expansion Tank 44
Check Boiler Relief Valve 45

REPLACEMENT PARTS

Replacement Parts 46-51

PRODUCT SPECIFICATIONS

Specifications 52-59

Definitions

The following terms are used to bring attention to the presence of potential hazards or important information concerning the product.

 **WARNING**

Indicates a hazardous situation which, if not avoided, could result in death, serious injury or substantial property damage.

NOTICE

Indicates special instructions on installation, operation or maintenance, which are important to equipment but not related to personal injury.

BEST PRACTICE

Indicates recommendations made by Triangle Tube for the installers which will help to ensure optimum operation and longevity of the equipment.

 **CAUTION**

Indicates a hazardous situation which, if not avoided, could result in minor or moderate injury or property damage.

Product & Safety Information

NOTICE

This supplement is intended for the installation of a Cascade Multiple Boiler Distribution Manifold and Optional Hydronic Junction with Prestige Solo 250 or Solo 399 Boilers. The Cascade is not intended for installation with any other Prestige Boilers. The installation of the Prestige Solo 250 or Solo 399 boilers in the Cascade configuration must be in accordance with the Prestige Solo 250 or Solo 399 Installation and Maintenance Manual and other corresponding supplements including venting.

NOTICE

Please reference the Cascade Distribution Manifold serial number on the inclined section of left leg when inquiring about service or troubleshooting of the manifold.

NOTICE

Please reference the Prestige Boiler serial number when inquiring about service or troubleshooting of the boiler.

NOTICE

Triangle Tube reserves the right to modify the technical specifications and components of its products without prior notice.

SECTION I – PRE-INSTALLATION ITEMS

Code Compliance

Installation of the Cascade must comply with local codes and requirements and with the latest edition of National Fuel Gas Code NFPA 54, ANSI Z223.1 for installations in the U.S. For Installations in Canada, the installations must comply with latest edition of CAN/CSA B149.1.

The installation of the Cascade must be installed in accordance with the Standards for Controls and Safety Devices for Automatically Fired Boilers ANSI/ASME CSD-1 (CSD-1) when required.

The Cascade must be fully constructed using ONLY the components from Triangle Tube.

Determine Location

Consider the following; piping, venting, gas, electric and drain when selecting a location for the Cascade.

Recommended Clearances

The PRESTIGE Solo 250 or Solo 399 is approved for zero clearances to combustibles, excluding vent and boiler piping.

- Vent & Boiler Piping – ¼” from combustible materials

BEST PRACTICE

To provide serviceability it is recommended that the following clearances be maintained from the Cascade:

- Top boiler jackets – 24 inches
- Front boiler jackets – 24 inches
- Bottom boiler jackets – 24 inches
- Rear of boiler jacket – 13 inches
- Left side of outer left boiler jacket – 9 inches
- Right side of outer right boiler jacket – 9 inches

WARNING

If the clearances listed above cannot be maintained for the Cascade or the enclosure in which the Cascade is installed is less than 85 cubic feet per Prestige Boiler, the space must be ventilated, see Prestige Installation and Maintenance Manual for ventilation requirements.

Consult local codes for any additional clearance requirements.

Cascade Kit Components

Prior to installation, check to ensure all parts required for the completion of the Cascade are present. See Figures 1- 6 and Tables 1 and 2, pages 3-8 for complete breakdown of Solo 250 boiler cascade kit components. See Figures 7-9 and Table 3 pages 9-10 for optional Solo 250 boiler reverse return with valve kit and kit components. See Figures 10 - 15 and Tables 4 and 5, pages 11-16 for complete breakdown of Solo 399 boiler cascade kit components. See Figures 16-18 and Table 6 pages 17-18 for optional Solo 399 boiler reverse return with valve kit and kit components. See page 19 for optional kits and kit components for both Solo 250 & 399 boilers.

Operating Restrictions

- Maximum water temperature is 200°F
- Maximum working pressure for PRESTIGE Solo 250 Boilers is 30 psig.
- Maximum working pressure for PRESTIGE Solo 399 Boilers is 30 psig.
- Maximum working pressure for PRESTIGE Solo 399HP is 80 psig.
- Maximum working pressure for Cascade Manifold is 80 psig.
- pH and chloride limits for water heaters are:
 - chloride, less than 150 mg/l (ppm)
 - pH value min. 6 - max. 8

NOTICE

Any water conditioning system must be installed and maintained in accordance with manufacturer’s specifications.

NOTICE

Do not install the Cascade on any application if the system piping contains non-oxygen barrier tubing or if the system is considered an “open system”. Exposing the Cascade to oxygen contamination will lead to premature failure and denial of the warranty.

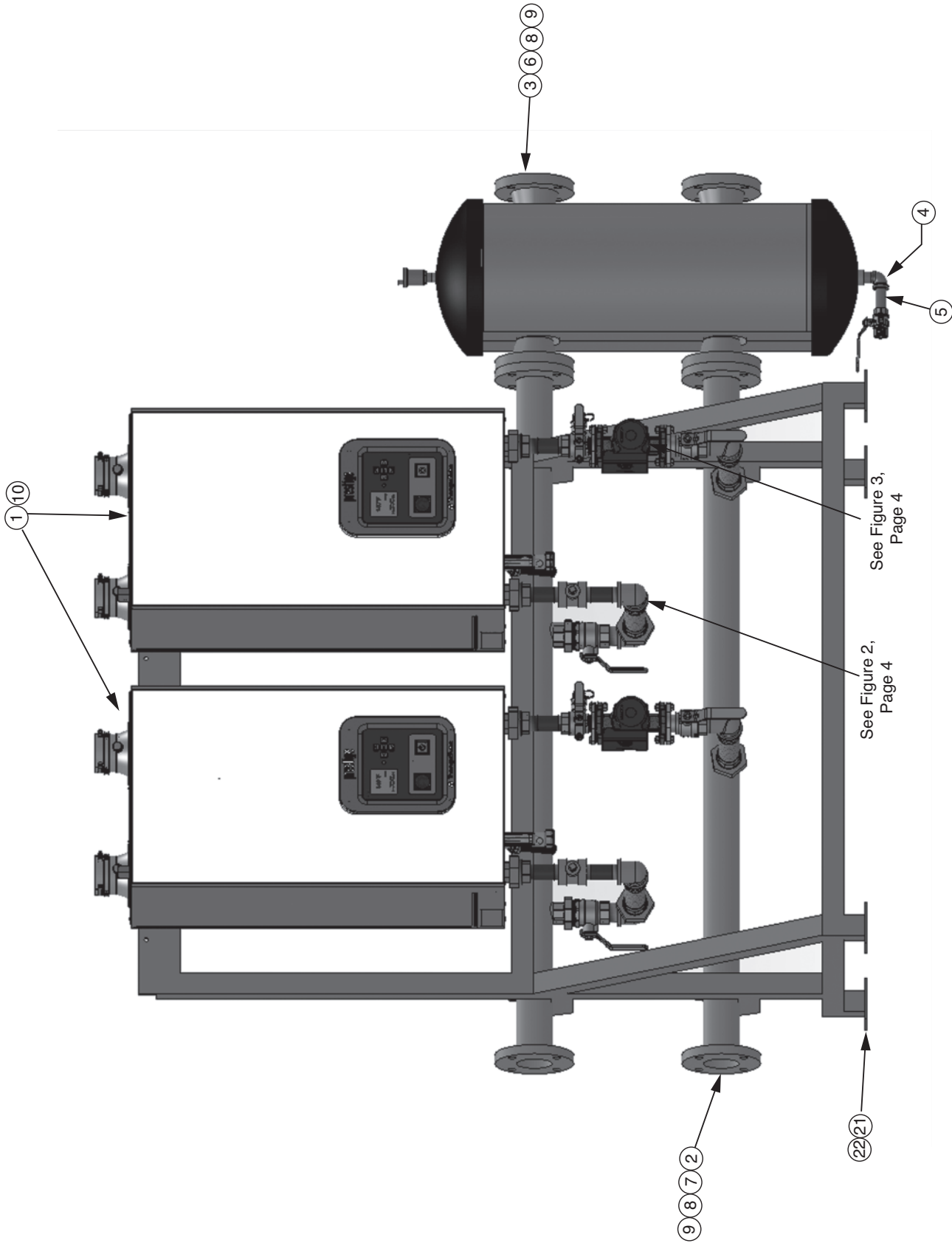

Fig. 1: Cascade Kit Components for Solo 250 Boilers – Primary Secondary (P/S) - See Table 1, Page 5

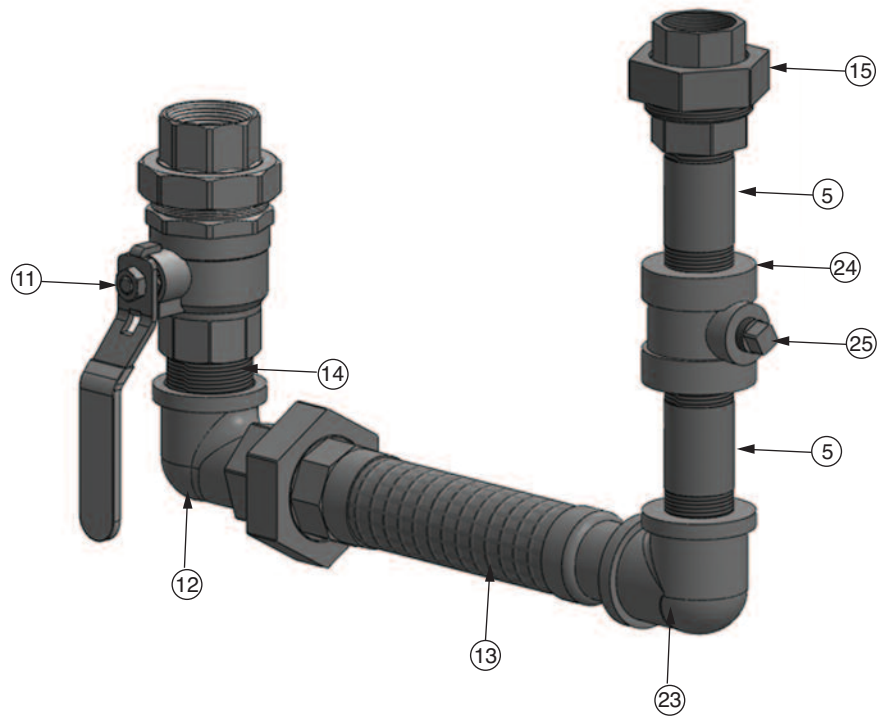

Fig. 2: Cascade Kit Components for Solo 250 Boilers – Primary Secondary Supply Piping- See Table 1, Page 5

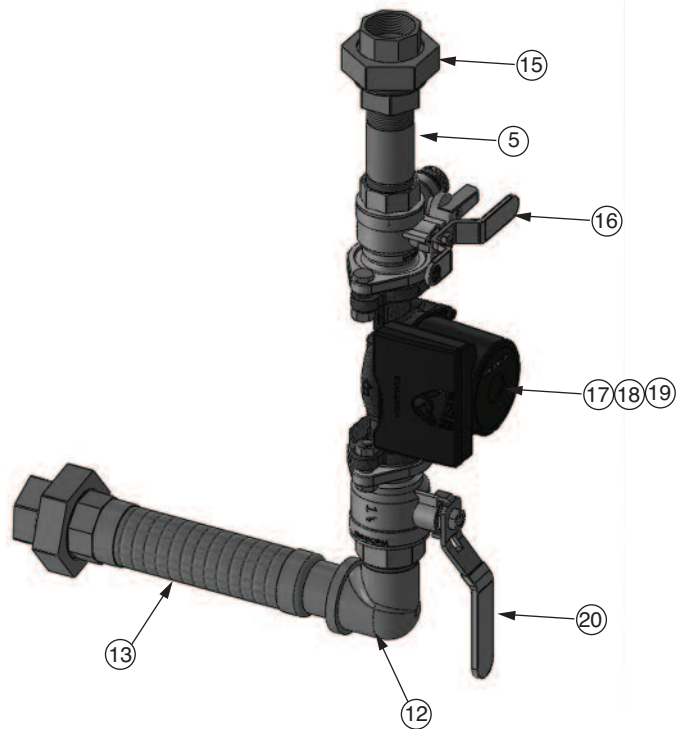

Fig. 3: Cascade Kit Components for Solo 250 Boilers – Primary Secondary Return Piping - See Table 1, Page 5

Table 1: Cascade Kit Components for Solo 250 Boilers – Primary Secondary (P/S) - See Figs. 1 - 3, Pages 3 & 4

Item	Kit Components	CPS 500	CPS1000
		Quantity	
1	Prestige Solo 250 Boiler	2	4
2	2 Boiler Manifold	1	2
3	Hydronic Junction with Insulation & Air Vent	1	1
4	1-1/4" NPT 90° Elbow	1	1
5	1-1/4" NPT x 4" Nipple	7	13
6	Flange - ANSI to 3" NPSC	2	2
7	Flange - ANSI to Blind	2	2
8	Gasket - ANSI	6	8
9	Flared Bolt & Nut – Flange (5/8-11 x 3")	24	32
10	Bolt, Washer & Nut – Boiler Mounting Bracket (5/16-18 x 3/4")	4	8
11	1-1/2" NPT Union/Shut Off Valve Assembly	2	4
12	1-1/2" NPT 90° Street Elbow	4	8
13	1-1/2" NPT x 13" Flexible Hose/Union Assembly	4	8
14	1-1/2" NPT x Close Nipple	2	4
15	1-1/4" NPT Union	4	8
16	1-1/4" NPT Drain/Shut Off Valve/Circulator Flange Assembly	2	4
17	Circulator – Grundfos UPS 15-58	2	4
18	Gasket – Circulator	4	8
19	Bolt & Nut - Circulator	8	16
20	1-1/2" NPT Circulator Flange/Shut Off Valve Assembly	2	4
21	Heavy-Duty Concrete Anchors with Washer & Nut	4	8
22	Concrete Drill Bit	1	2
23	1-1/2" NPT & 1 1/4" NPT 90° Reducing Elbow 2	2	4
24	1-1/4" NPT x 1/2" NPT x 1-1/4" NPT Inline Reducing Tee	2	4
25	1/2" NPT Plug	2	4

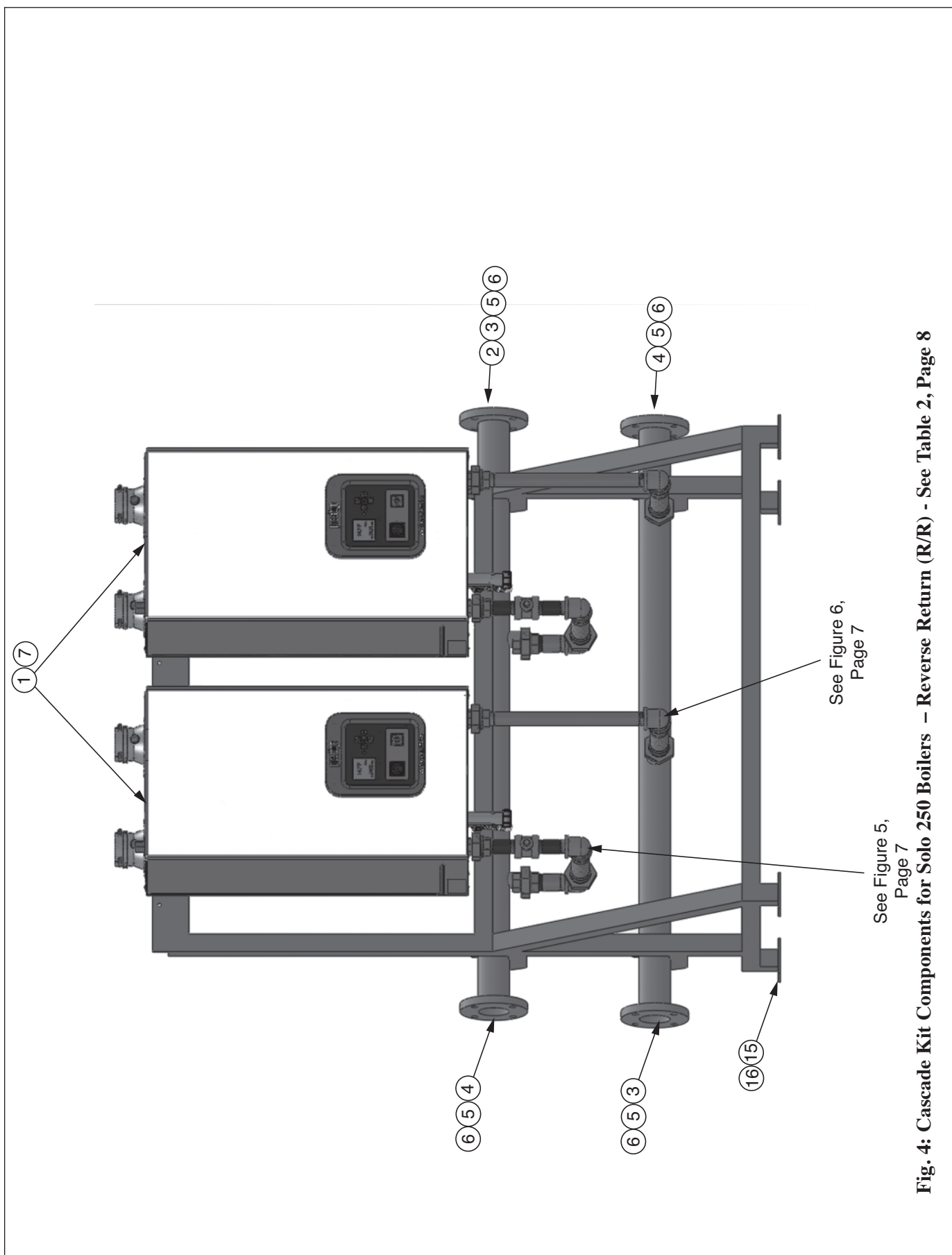

Fig. 4: Cascade Kit Components for Solo 250 Boilers – Reverse Return (R/R) - See Table 2, Page 8

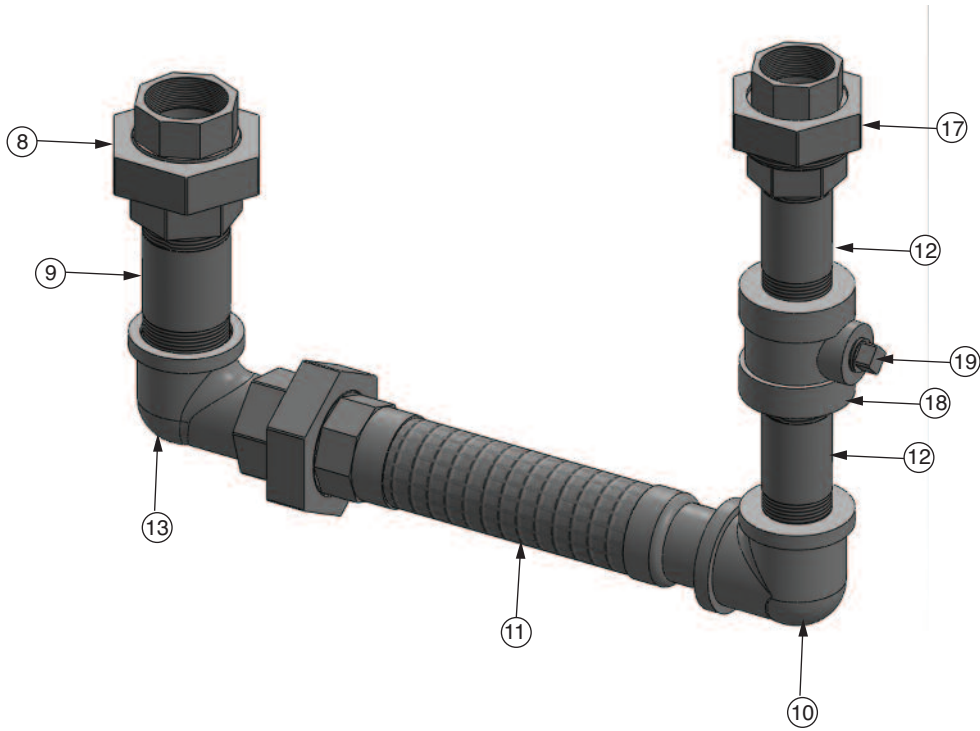

Fig. 5: Cascade Kit Components for Solo 250 Boilers - Reverse Return Supply Piping - See Table 2, Page 8

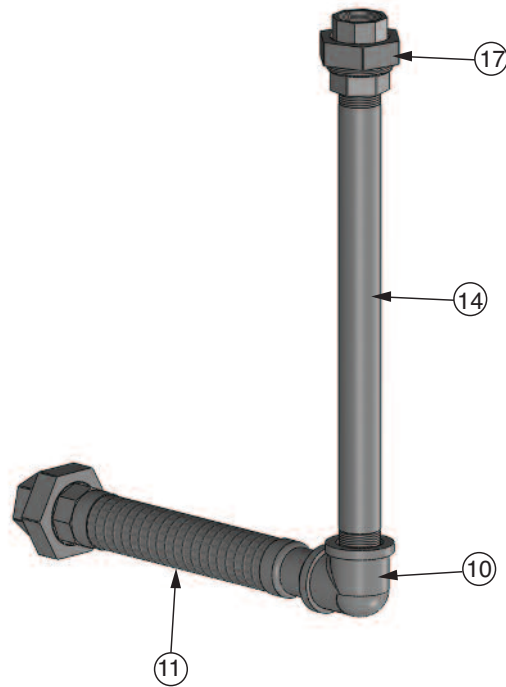

Fig. 6: Cascade Kit Components for Solo 250 Boilers - Reverse Return Return Piping - See Table 2, Page 8

Table 2: Cascade Kit Components for Solo 250 Boilers Reverse Return (R/R) - See Figs, 4-6, Pages 6&7

Item	Kit Components	CRR500	CRR1000
		Quantity	
1	Prestige Solo 250 Boiler	2	4
2	2 Boiler Manifold	1	2
3	Flange - ANSI to 3" NPSC	2	2
4	Flange - ANSI to Blind	2	2
5	Gasket - ANSI	4	6
6	Flared Bolt & Nut – Flange (5/8-11 x 3")	16	24
7	Bolt, Washer & Nut – Boiler Mounting Bracket (5/16-18 x 3/4")	4	8
8	1-1/2" NPT Union	2	4
9	1-1/2" NPT x 4" Nipple	2	4
10	1-1/2" NPT x 1 1/4" NPT 90° Reducing Elbow	4	8
11	1-1/2" NPT x 13" Flexible Hose/Union Assembly	4	8
12	1-1/4" NPT x 4" Nipple	4	8
13	1-1/2" NPT 90° Street Elbow	2	4
14	1-1/4" NPT x 13" Pipe	2	4
15	Heavy-Duty Concrete Anchors with Washer & Nut	4	8
16	Concrete Drill Bit	1	2
17	1-1/4" NPT Union	4	8
18	1-1/4" NPT x 1/2" NPT x 1 1/4" NPT Inline Reducing Tee	2	4
19	1/2" NPT Plug	2	4

BEST PRACTICE

It's recommended to install Reverse Return with Valves to allow for isolation of an individual boiler for servicing.

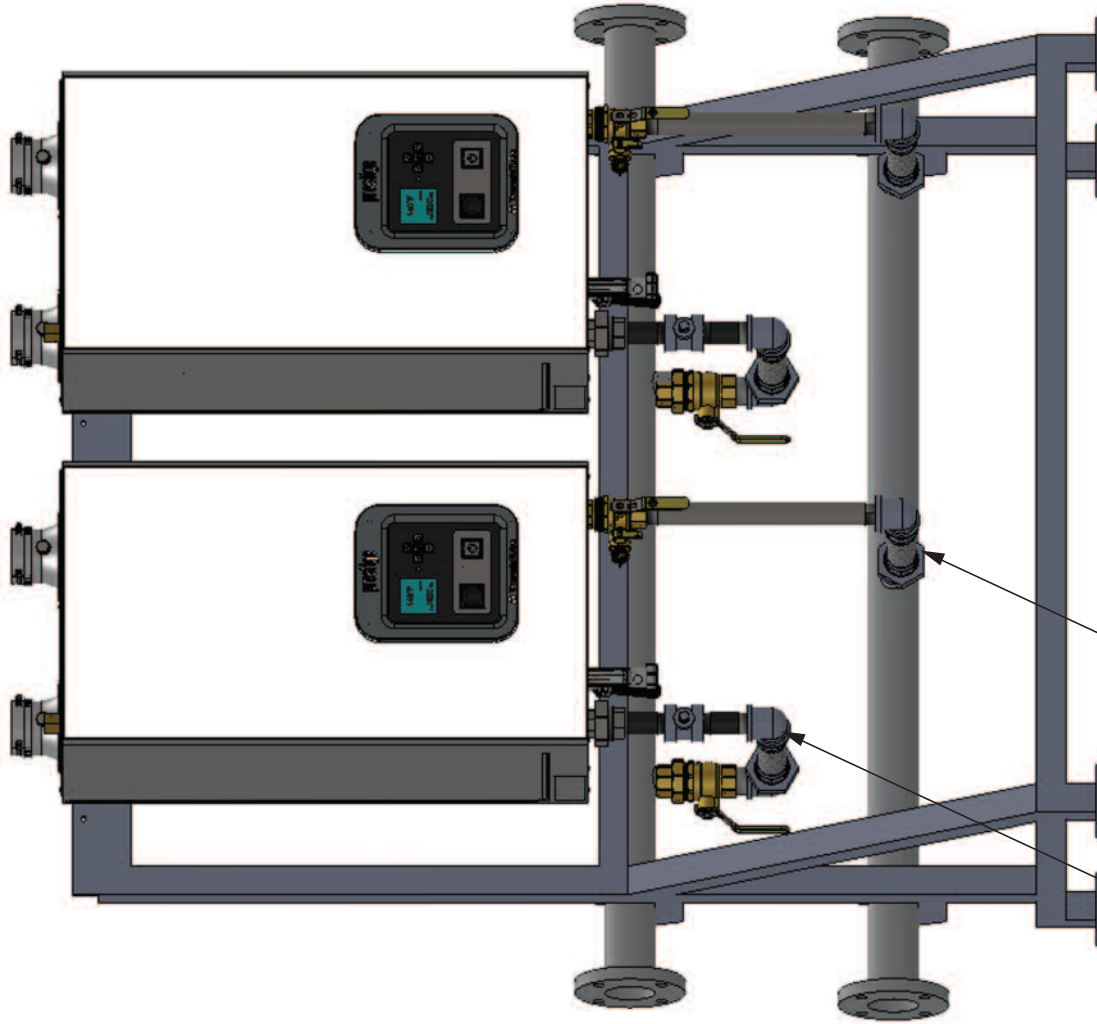

See Figure 8,
Page 10

See Figure 9,
Page 10

Fig. 7: Optional Kit Components for Solo 250 – R/R with Valves - Shut Off & Drain - See Table 3, Page 10

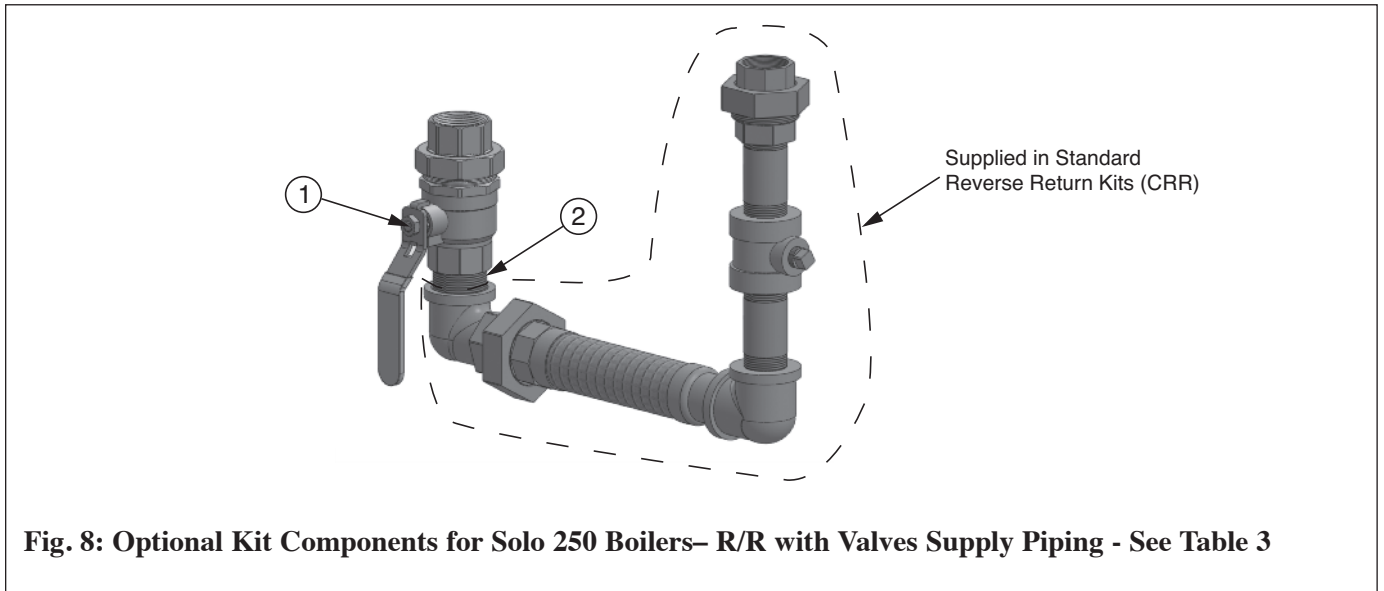

Fig. 8: Optional Kit Components for Solo 250 Boilers– R/R with Valves Supply Piping - See Table 3

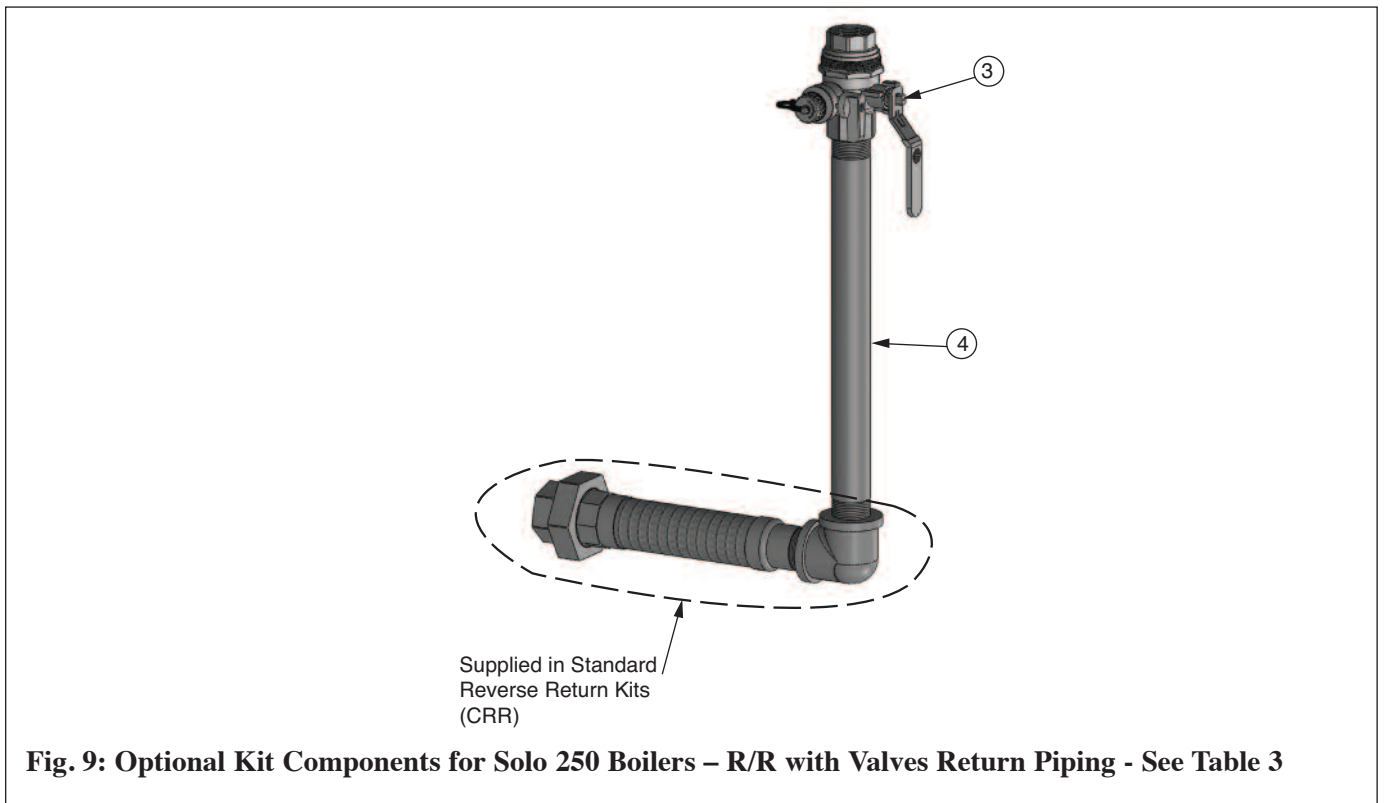

Fig. 9: Optional Kit Components for Solo 250 Boilers – R/R with Valves Return Piping - See Table 3

Table 3: Optional Kit Components for Solo 250 Boilers – R/R with Valves - See Figures 7 - 9, Pages 9 & 10

Item	Kit Components	PSCAS31 (1/Boiler)
		Quantity
1	1-1/2" NPT Union/Shut Off Valve Assembly	1
2	1-1/2" NPT Close Nipple	1
3	1-1/4" NPT Union/Drain/Shut Off Valve Assembly	1
4	1-1/4" NPT x 16" Pipe	1

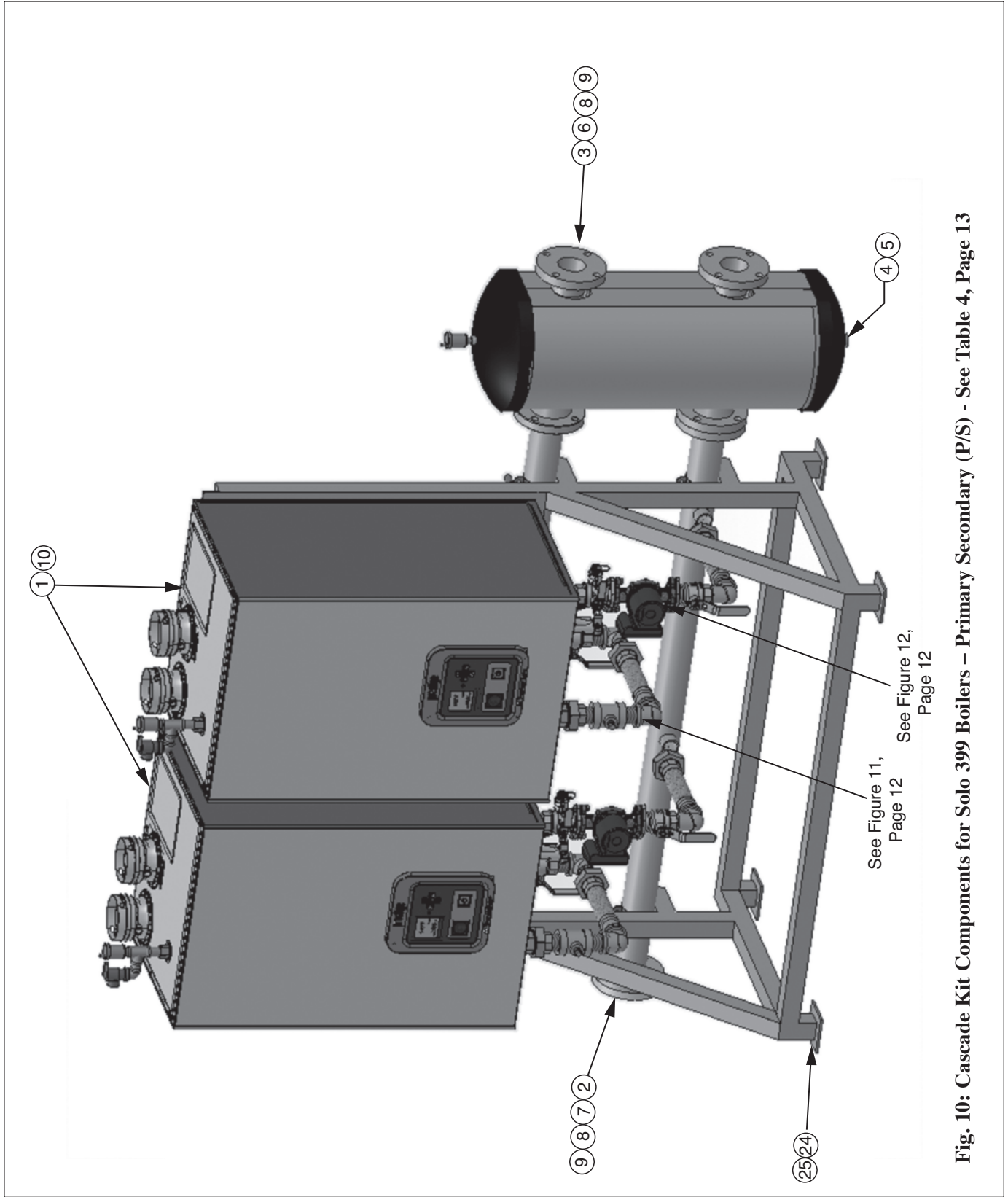

Fig. 10: Cascade Kit Components for Solo 399 Boilers – Primary Secondary (P/S) - See Table 4, Page 13

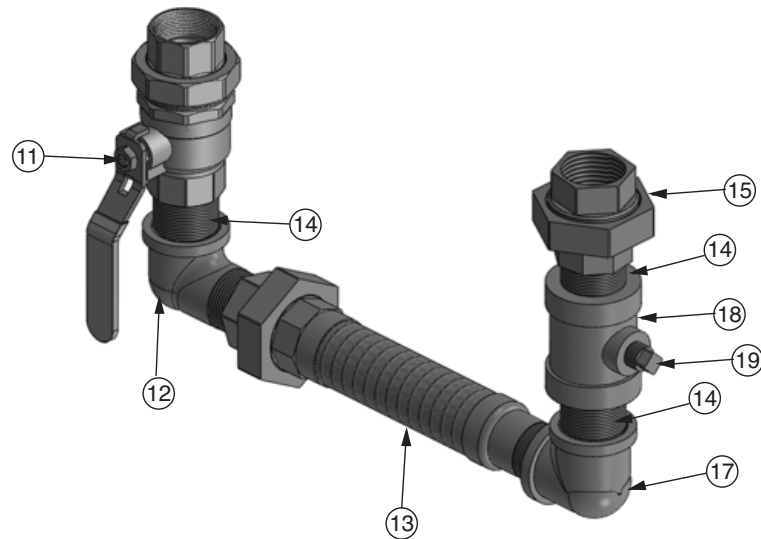

Fig. 11: Cascade Kit Components for Solo 399 Boilers – Primary Secondary Supply Piping- See Table 4, Page 13

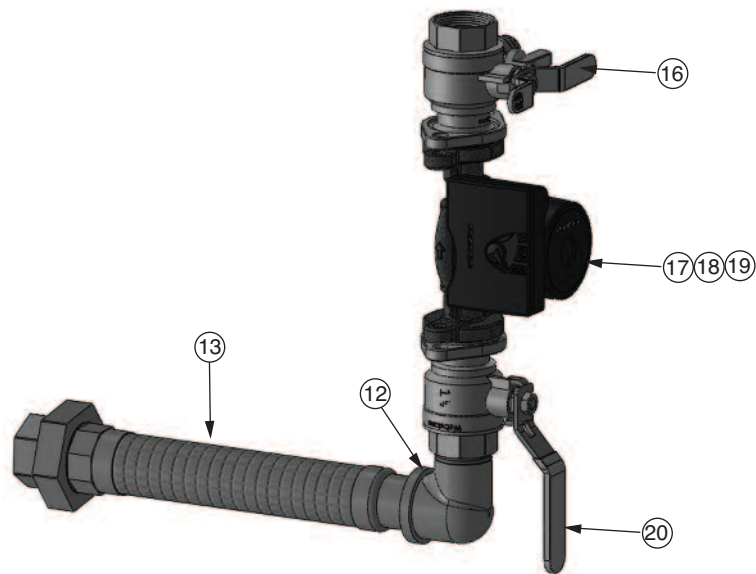
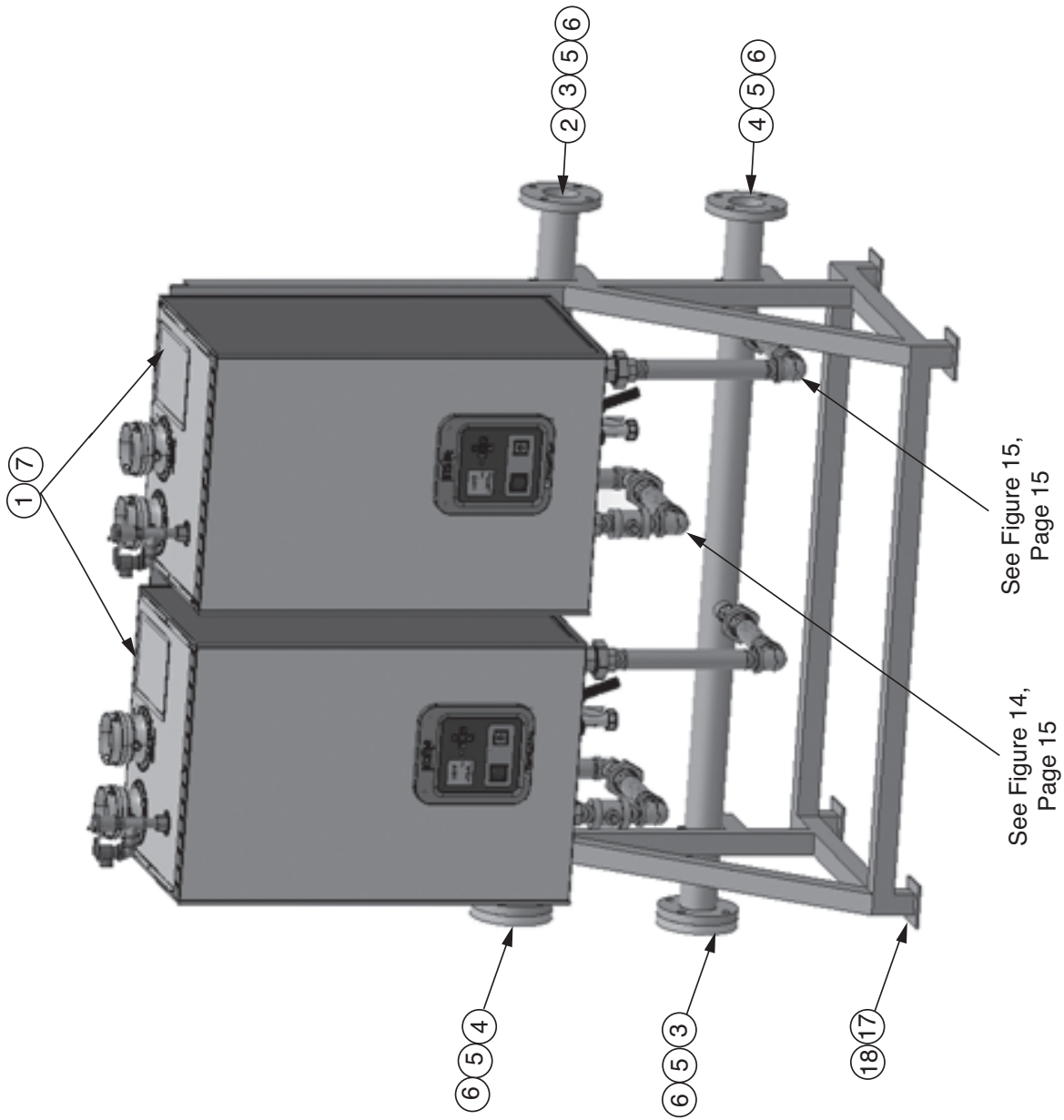

Fig. 12: Cascade Kit Components for Solo 399 Boilers – Primary Secondary Return Piping - See Table 4, Page 13

Table 4: Cascade Kit Components for Solo 399 Boilers – Primary Secondary (P/S) - See Figs. 10 - 12, Pages 11 & 12

Item	Kit Components	CPS800	CPS1200	CPS1600	CPS2000
		Quantity			
1	Prestige Solo 399 Boiler	2	3	4	5
2	2 Boiler Manifold	1	0	2	1
	3 Boiler Manifold	0	1	0	1
3	Hydronic Junction with Insulation & Air Vent	1	1	1	1
4	1-1/4" NPT 90° Elbow	1	1	1	1
5	1-1/4" NPT x 4" Nipple	1	1	1	1
6	Flange - ANSI to 3" NPSC	2	2	2	2
7	Flange - ANSI to Blind	2	2	2	2
8	Gasket - ANSI	6	6	8	8
9	Flared Bolt & Nut – Flange (5/8-11 x 3")	24	24	32	32
10	Bolt, Washer & Nut – Boiler Mounting Bracket (5/16-18 x 3/4")	4	6	8	10
11	1-1/2" NPT Union/Shut Off Valve Assembly	2	3	4	5
12	1-1/2" NPT 90° Street Elbow	4	6	8	10
13	1-1/2" NPT x 15" Flexible Hose/Union Assembly	4	6	8	10
14	1-1/2" NPT x Close Nipple	6	9	12	15
15	1-1/2" NPT Union	2	3	4	5
16	1-1/2" NPT Drain/Shut Off Valve/Circulator Flange Assembly	2	3	4	5
17	1-1/2" NPT 90° Elbow	2	3	4	5
18	1-1/2" NPT x 1/2" NPT x 1-1/2" NPT Inline Reducing Tee	2	3	4	5
19	1/2" NPT Plug	2	3	4	5
20	Circulator – Grundfos UPS 26-99FC	2	3	4	5
21	Gasket – Circulator	4	6	8	10
22	Bolt & Nut - Circulator	8	12	16	20
23	1-1/2" NPT Circulator Flange/Shut Off Valve Assembly	2	3	4	5
24	Heavy-Duty Concrete Anchors with Washer & Nut	4	4	8	8
25	Concrete Drill Bit	1	1	2	2



See Figure 15,
Page 15

See Figure 14,
Page 15

Fig. 13: Cascade Kit Components for Solo 399 – Reverse Return (R/R) - See Table 5, Page 16

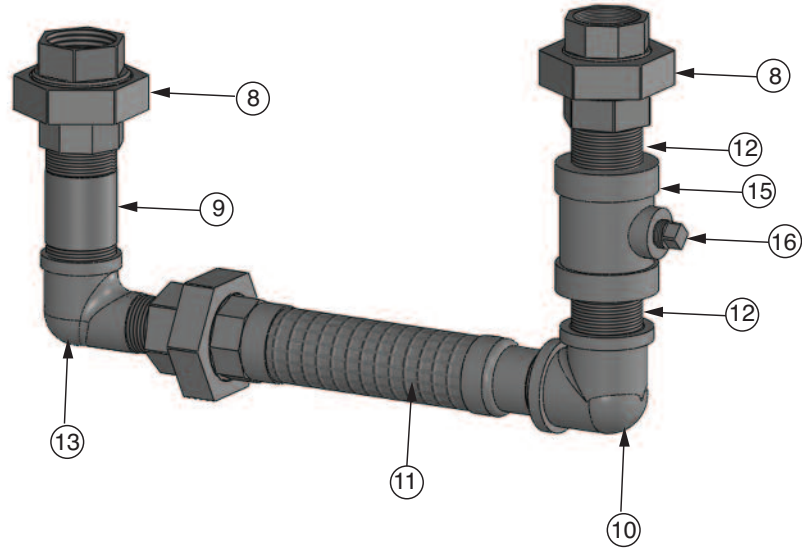

Fig. 14: Cascade Kit Components for Solo 399 Boilers - Reverse Return Supply Piping - See Table 5, Page 16

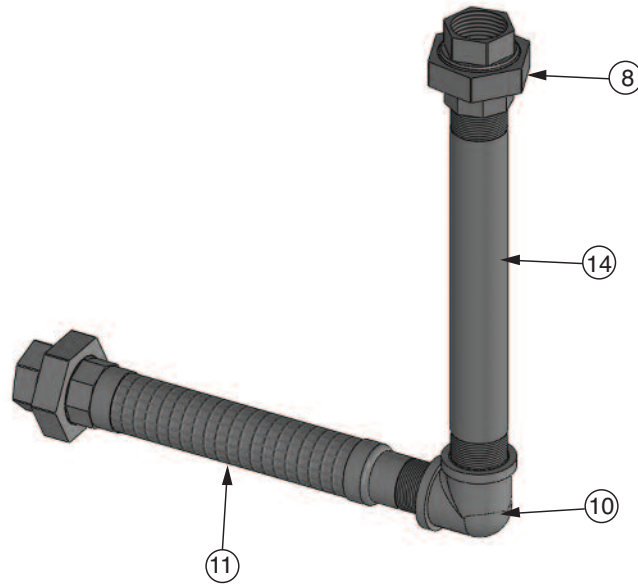

Fig. 15: Cascade Kit Components for Solo 399 Boilers - Reverse Return Return Piping - See Table 5, Page 16

Table 5: Cascade Kit Components for Solo 399 Boilers Reverse Return (R/R) - See Figs, 13-15, Pages 14 & 15

Item	Kit Components	CRR800	CRR1200	CRR1600	CRR2000
		Quantity			
1	Prestige Solo 399 Boiler	2	3	4	5
2	2 Boiler Manifold	1	0	2	1
	3 Boiler Manifold	0	1	0	1
3	Flange - ANSI to 3" NPSC	2	2	2	2
4	Flange - ANSI to Blind	2	2	2	2
5	Gasket - ANSI	4	4	6	6
6	Flared Bolt & Nut – Flange (5/8-11 x 3")	16	16	24	24
7	Bolt, Washer & Nut – Boiler Mounting Bracket (5/16-18 x 3/4")	4	6	8	10
8	1-1/2" NPT Union	6	9	12	15
9	1-1/2" NPT x 4" Nipple	2	3	4	5
10	1-1/2" NPT 90° Elbow	4	6	8	10
11	1-1/2" NPT x 15" Flexible Hose/Union Assembly	4	6	8	10
12	1-1/2" NPT x Close Nipple	4	6	8	10
13	1-1/2" NPT 90° Street Elbow	2	3	4	5
14	1-1/2" NPT x 13-1/2" Pipe	2	3	4	5
15	1-1/2" NPT x 1/2" NPT x 1-1/2" NPT Inline Reducing Tee	2	3	4	5
16	1/2" NPT Plug	2	3	4	5
17	Heavy-Duty Concrete Anchors with Washer & Nut	4	4	8	8
18	Concrete Drill Bit	1	1	2	2

BEST PRACTICE

It's recommended to install Reverse Return with Valves to allow for isolation of an individual boiler for servicing.

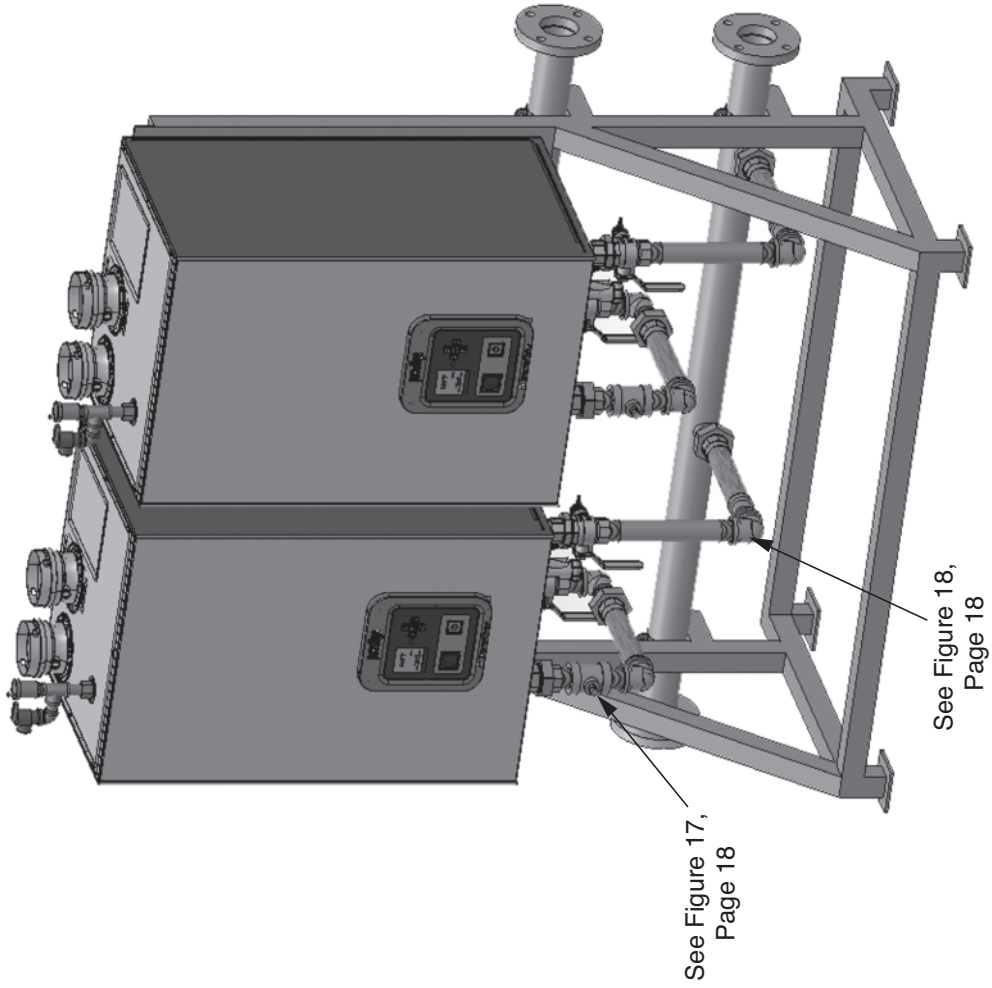

Fig. 16: Optional Kit for Solo 399 Boilers – R/R with Valves - Shut Off & Drain - See Table 6, Page 18

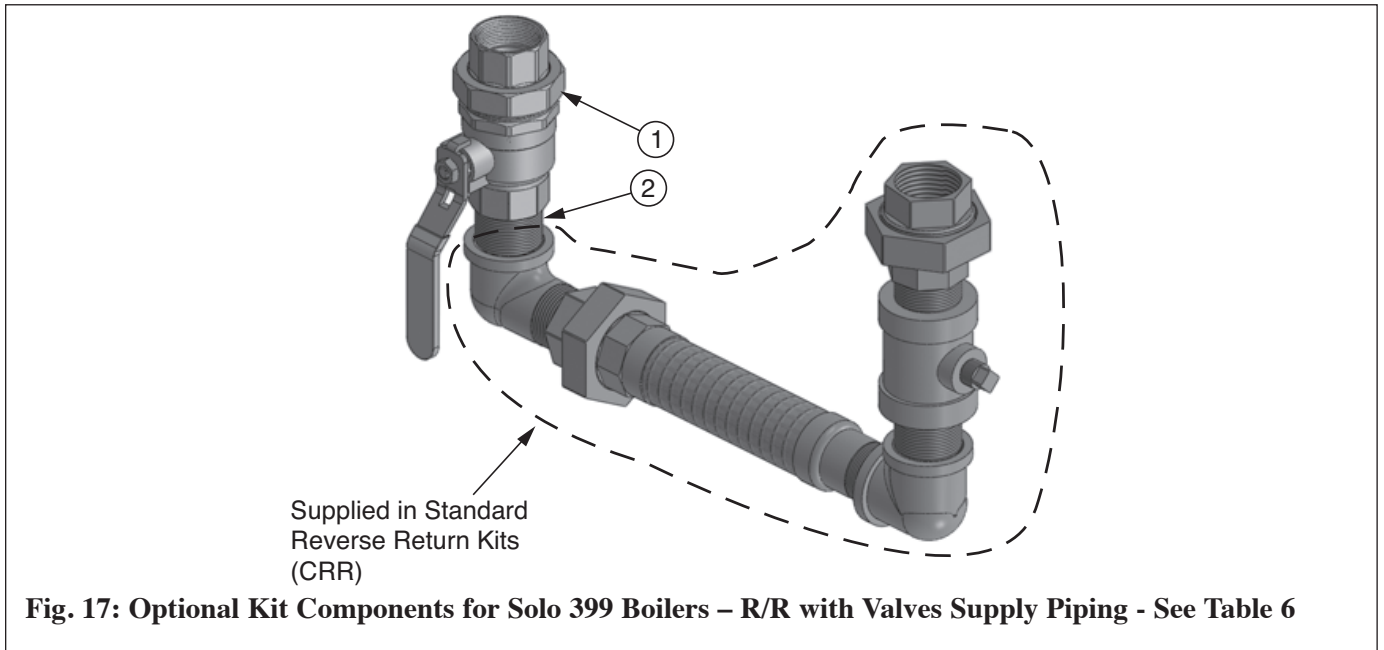

Fig. 17: Optional Kit Components for Solo 399 Boilers – R/R with Valves Supply Piping - See Table 6

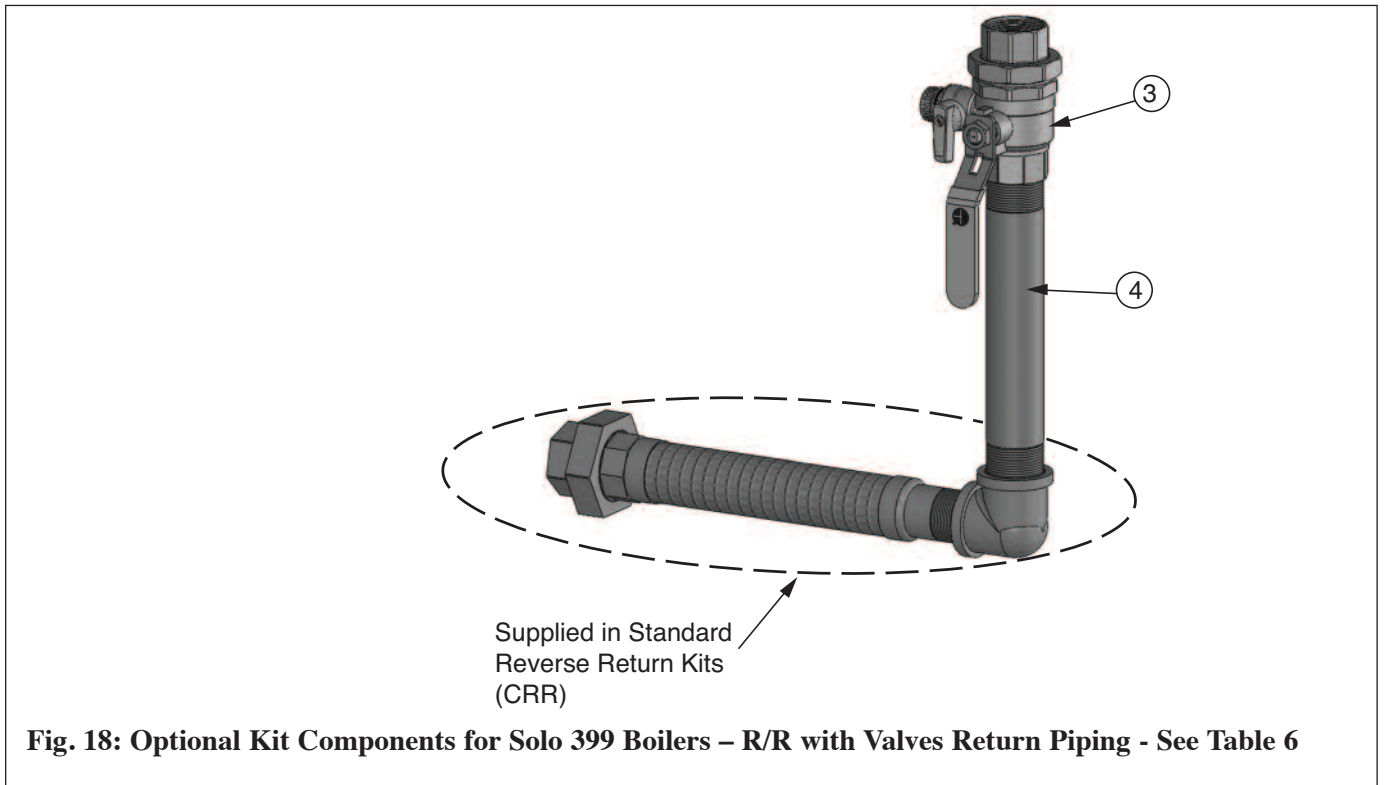

Fig. 18: Optional Kit Components for Solo 399 Boilers – R/R with Valves Return Piping - See Table 6

Table 6: Optional Kit Components for Solo 399 – R/R with Valves - See Figures 16 - 18, Pages 17 & 18

Item	Kit Components	PSCAS32 (1/Boiler)
		Quantity
1	1-1/2" NPT Union/Shut Off Valve Assembly	1
2	1-1/2" NPT 90° Close Nipple	1
3	1-1/2" NPT Union/Drain/Shut Off Valve Assembly	1
4	1-1/2" NPT x 10" Pipe	1

BEST PRACTICE

The CRR models (Reverse Return (R/R)) and the optional R/R with Valves kit do not include any balancing valve(s). It is recommended to balance the flow through the individual R/R boilers. This balancing can be accomplished by installing a balancing valve on the return pipe of each boiler.

Table 7: Optional Kit Components – CSD-1 for P/S & R/R with Valves

Item	Kit Components	PSCAS17 (1/Boiler)
		Quantity
1	Brass 3/4" NPT 90 Degree Elbow	1
2	Brass 3/4" NPT Shoulder Nipple	1
3	Brass 3/4" NPT Tee	1
4	Brass 3/4" Close Nipple	1
5	LWCO with Probe	1
6	Drywell 1/2" NPT with 1.5" Long Well	1
7	Heat Conductive Compound	1
8	High Limit	1
9	Wire Splice	1

NOTICE

CSD-1 for R/R: The LWCO with probe, High Limit, Drywell and heat conductive compound can be ordered separately, see page 46 for part numbers.

Table 8 : Optional Kit Components – R/R Strainer

Item	Kit Components	PSCAS24 (1/Cascade)
		Quantity
1	Wye Strainer with 3" ANSI Flanges	1
2	Gaskets	2
3	Bolt & Nut (5/8 - 11" x 3") - Flanged	8

SECTION II – COMBUSTION AIR AND VENTING



For detailed instructions regarding the installation of the combustion air and venting, reference the **PRESTIGE Installation and Maintenance Manual**, **PRESTIGE Vent Supplement** and /or the various optional vent kit instructions.

Both the **PRESTIGE Solo Installation and Maintenance Manual** and **PRESTIGE Vent Supplement** is included in each boiler's installation envelope. For instructions or information regarding the optional side wall vent / air kits shown below in Figs 19 & 20, contact Triangle Tube Technical Support.

Each boiler must be individually vented and supplied with combustion air.

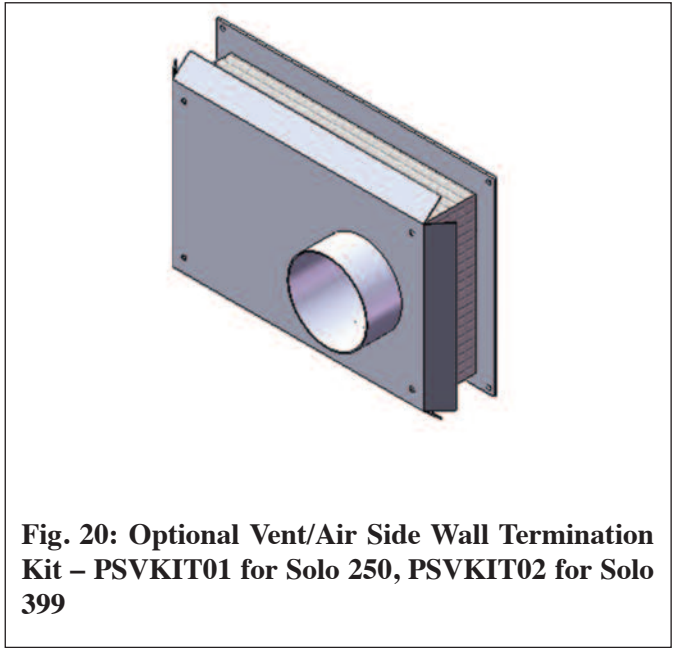

Fig. 20: Optional Vent/Air Side Wall Termination Kit – PSVKIT01 for Solo 250, PSVKIT02 for Solo 399

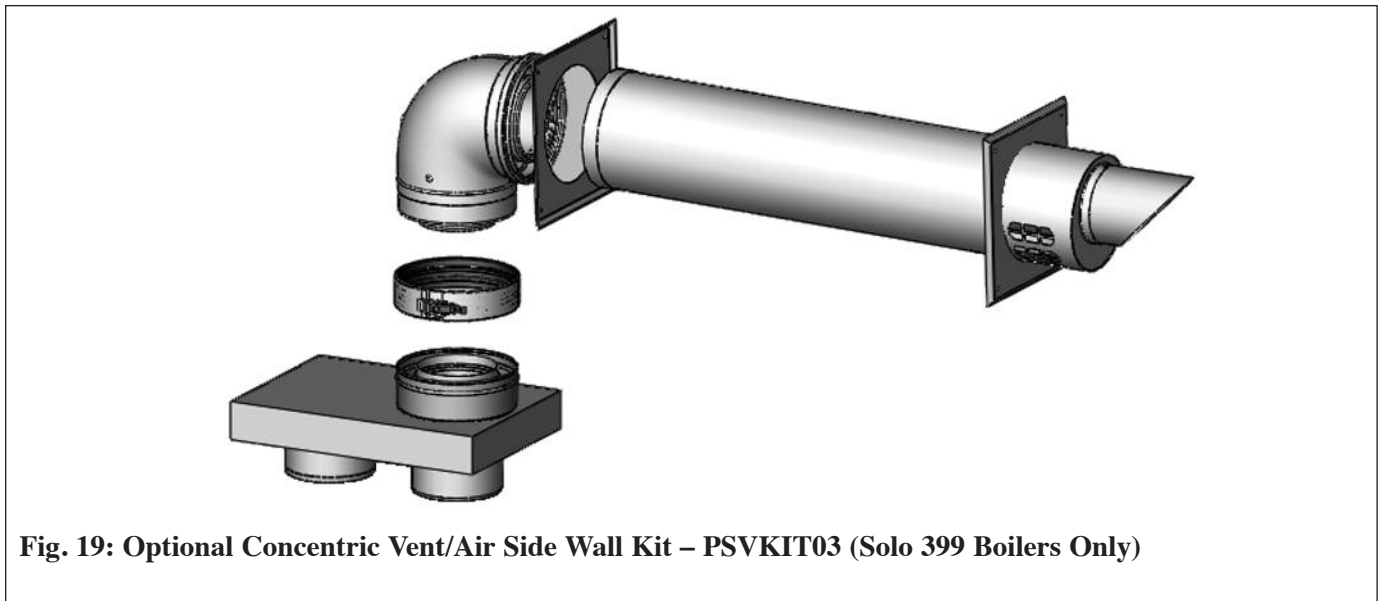

Fig. 19: Optional Concentric Vent/Air Side Wall Kit – PSVKIT03 (Solo 399 Boilers Only)

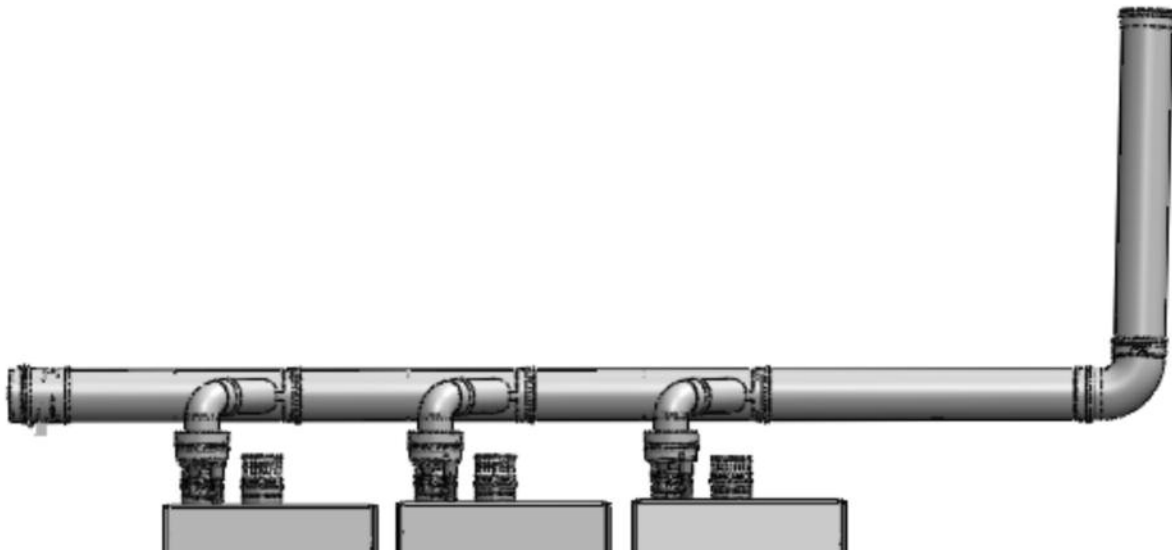

Fig. 21: Optional Common Venting of 2 or 3 PRESTIGE Solo 399 Boilers (Not Available for Solo 250 Boilers)

For instructions or information regarding Common Venting of 2 or 3 PRESTIGE Solo 399 Boilers as shown in Fig. 21, contact Triangle Tube Technical Support.

SECTION III – INSTALLATION

Distribution Manifold

1. Place the distribution manifold in the location to be installed. If a Hydronic Junction is utilized consideration must be made in determining location.
2. Level distribution manifold .
3. Secure manifold to floor. To secure the manifold to the floor, drill and install anchors (supplied with Cascade) in floor through the holes in the legs of the distribution manifold, one per leg.

BEST PRACTICE

For optimum support of the weight of the Cascade it is recommended to secure the distribution manifold to the floor, especially when utilizing multiple distribution manifolds.

4. Install blind flange (seal plate) on the distribution manifold with gasket and hardware supplied, see Figure 22. For primary secondary applications, this flange should be installed on the distribution manifold on the end opposite to the hydronic junction. For reverse return applications the top blind flange should be installed opposite of the system supply piping. Install the bottom blind flange opposite of the system return piping, which is also opposite the top blind flange.

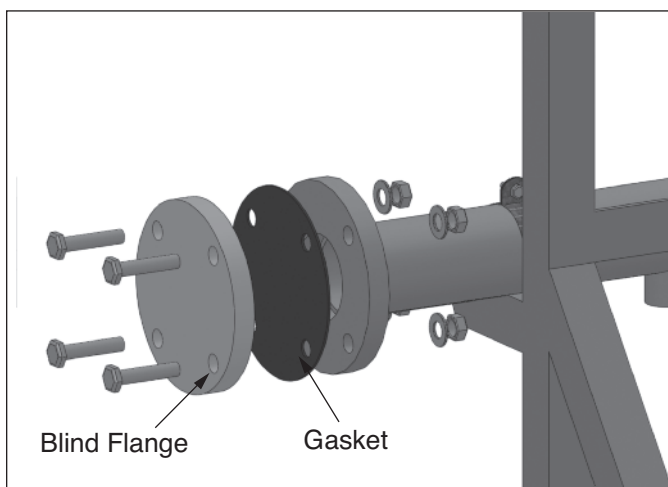

Fig. 22: Blind Flange Manifold Installation

5. Install ANSI to 3” NPSC connection flanges to the system supply (top) and system return (bottom) connections utilizing the gasket and hardware supplied.

Multiple Distribution Manifolds

The maximum number of boilers that can be piped using multiple Cascade Distribution Manifolds is five. When connecting multiple manifold a 2 Boiler Distribution Manifold with another 2 Boiler Distribution Manifold or with a 3 Boiler Distribution Manifold, utilize the gaskets and hardware supplied in kits to join the two manifolds.

Hydronic Junction

The hydronic junction serves as a low loss header providing hydraulic separation, dirt separation and air elimination.

NOTICE

When utilizing a hydronic junction the mixed system supply temperature can be calculated as follows:

$$\text{System Supply Temp.} = \frac{[(\text{Boiler Supply Temp.} \times \text{Boiler Flow Rate}) + (\text{System Return Temp.} \times \text{Bypass Flow Rate})]}{\text{System Flow Rate}}$$

$$\text{Bypass Flow Rate} = (\text{System Flow Rate} - \text{Boiler Flow Rate})$$

When the boiler/Cascade flow rate does not equal the system flow rate, the total heat output of the boilers/Cascade will be absorbed by the system when the following conditions are met:

- The boiler/Cascade supply temperature is greater than the system supply temperature.
- The boiler/Cascade flow rate is less than the system flow rate.
- The return temperature of the system is equal to the return temperature of the boiler /Cascade.

NOTICE

The installation of the hydronic junction only applies when the Cascade system is configured in a primary secondary arrangement. The maximum number of boilers that can be piped up to a single hydronic junction is five. The hydronic junction can be installed on either the right or left side of the distribution manifold. The hydronic junction can be rotated 180 degrees about its height or vertical axis.

1. Place the hydronic junction in the location to be installed. The distribution manifold must be considered in determining location.
2. Connect the hydronic junction to the distribution manifold using the gaskets and hardware provided.
3. Level distribution manifold and hydronic junction.

4. Install air vent and drain valve in the Hydronic Junction, see Figure 23. The air vent should be installed in the top tapping as shown. The drain valve (1-1/4" NPT shut off valve) should be installed horizontally using a 1- 1/4" NPT 90° elbow and 1-1/4" NPT x 4" nipple in the tapping located at the bottom. The handle on the shut off valve will need to be in the horizontal position when the valve is closed. Remove handle and install accordingly.

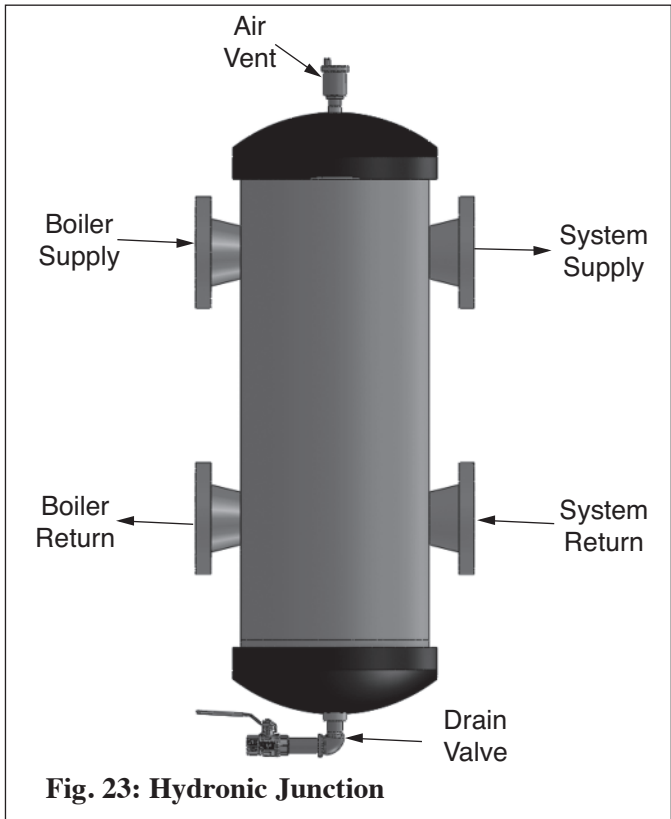

Fig. 23: Hydronic Junction

Insulation

BEST PRACTICE

It's recommended to install insulation to minimize standby losses.

Position and secure insulation to hydronic junction as shown in Fig. 23.

Boiler Mounting

1. Attach the boiler mounting brackets shipped with the boilers to the top front of the distribution manifold using the hardware supplied, see Figure 24. Ensure brackets are level.

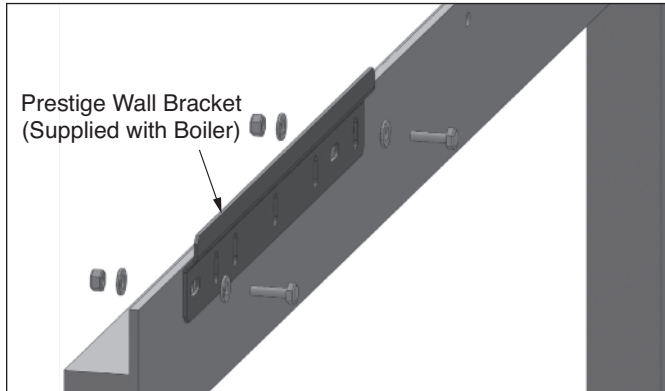

Fig. 24: Prestige Wall Bracket Installations

2. Remove the front doors from the boilers and carefully lift boilers by internal supply and return pipes. Obtain assistance in lifting the boilers onto the boiler mounting brackets. Make sure the boiler mounting lip located along the upper edge of the rear boiler jacket panel engages the boiler mounting bracket. Ensure each boiler is seated properly and is secure.

NOTICE

Remove the front door from all boilers before mounting boilers on brackets. Carefully lift boilers using the supply / return pipes in the boilers, onto the mounting brackets.

⚠ WARNING

Use extreme care not to drop the boiler or cause bodily injury while lifting or mounting the boiler onto the bracket. Once mounted verify that the boiler is securely attached to the bracket. Failure to comply with the above guidelines could result in property damage, personal injury or death.

SECTION IV – BOILER PIPING

General**NOTICE**

Ensure that the maximum boiler and distribution manifold working pressure does not exceed the maximum pressure rating of the boiler.

Connect the supply piping and return piping from the distribution manifold to each boiler. If necessary to align the supply and return pipes you can slide the boiler(s) on the boiler mounting bracket(s).

NOTICE

Use a high quality sealant for sealing all threaded connections, similar to Loctite 577. Assemble and tighten pipes in the proper orientation within the sealants working/cure time.

Pipe individual boilers as shown in the appropriate figures 1 through 18, pages 3-18.

SECTION V – CSD-1 INSTALLATION

If local codes require the installation to comply with CSD-1, the addition of high limit control(s) and low water cut off control(s) are required. The quantity and location of the controls vary depending on the installation.

P/S or R/R with Valves Kit – PSCAS17

In these installations the boilers can be individually isolated and therefore both a high limit control and a low water cut off control are required for each boiler. An optional kit PSCAS17 is required for each boiler, see Table 7, page 19 for a breakdown of kit components.

1. The high limit control will need to be installed in the supply piping directly below the boiler. Remove 1/2" NPT plug in supply piping and install drywell from PSCAS17 kit.
2. Install sensing bulb of the high limit control with heat conductive compound into the drywell, both the limit and heat conductive compound are supplied in the kit.
3. Secure limit to well using clamp supplied with limit.
4. Low water cut off control for each boiler will need to be positioned above the boiler combustion chamber.
5. The standard field installed air vent and pressure relief valve configuration will need to be repositioned, see Figure 27.

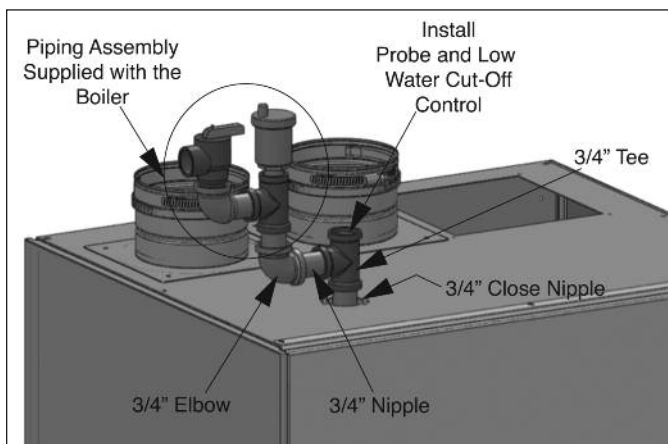

Fig. 27: Low Water Cut-Off Installation

6. A 3/4" NPT brass tee will need to be installed at the top of each boiler utilizing 3/4" NPT brass close nipple, both supplied in kit. Install tee with the branch portion facing horizontally.
7. Low water cut off control and probe supplied in the kit should be installed vertically in the top flow through portion of tee.
8. A 3/4" NPT brass nipple should be installed in the branch portion of the tee along with a brass 3/4" NPT 90 degree elbow, both supplied in kit.
9. The standard field installed air vent and pressure relief valve configuration (supplied with the boiler) should be installed in the top of elbow, see Figure 27.

Reverse Return (R/R)

In this installation a shut off valve will need to be installed on both the system supply and return connections. A drain should also be installed before the system return shut off valve. In this configuration the boilers cannot be individually isolated therefore a single low water cut off and manual high limit will be required in the system supply piping before the system supply shut off valve. The low water cut off must be installed in the system piping above the boilers. The low water cut off with probe and manual high limit and dry well can be field supplied or ordered separately, see page 45 for part number.

SECTION VI – SYSTEM PIPING

Multiple Distribution Manifolds

The maximum number of boilers that can be piped in series is five. If installing more than five boilers you will need to install the boilers in banks of no more than 5 boilers per bank. The multiple banks should only consist of Primary Secondary Cascade Kits to ensure adequate flow through boilers. The system piping between these boiler banks should be piped in parallel, see Figure 29, page 31. The parallel system piping between banks may require a balancing valve(s) if installing an uneven number of boilers per bank (i.e. 4 boiler bank, with a 2 boiler bank), see Figure 30, page 32.

System Piping

NOTICE

The system piping must be a “closed” system to avoid any oxygen contamination and potential failure of the Cascade.

1. The minimum recommended system iron pipe size is listed in Table 9. This table provides the individual boiler and system flow rates at various system temperature differences. This table also lists system piping pressure drops per 100 feet of system piping.
2. To determine the system pressure drop, calculate the total equivalent length (T.E.L.) of pipe for each valve and fitting in the system piping in the appropriate pipe size using Table 10 page 28. Add the T.E.L. to the actual straight length of system pipe of the same size.
3. Once you have calculated the T.E.L. of system pipe based on a specific pipe size, multiply it by the pressure

drop/100 feet listed for the pipe size to establish the total circuit pressure drop for that pipe size. If using various pipe sizes in the system, you will need to do this calculation for each pipe size separately and add the total pressure drops of all sizes to get a total system pressure drop.

NOTICE

When sizing the system piping and components, it’s recommended to use a minimum flow rate of 11 gpm per Solo 250 boiler or 19 gpm per Solo 399 boiler in the cascade to limit the flow velocity to 4 feet/second and the friction loss (pressure drop) to 4.2 feet/100 feet of pipe. Size system piping and components using approved/recognized design methods, if necessary contact Triangle Tube Technical Support for assistance.

BEST PRACTICE

It is recommended to utilize a primary/secondary Cascade when the total system flow rate is greater than 22 gpm per Solo 250 boiler or 38 gpm per Solo 399 boiler or less than 11 gpm per Solo 250 boiler or 19 gpm per Solo 399 boiler. A primary/secondary Cascade is also recommended when the system flow rate and pressure drop are unknown.

See Figure 31, page 33 for P/S Cascade system piping. See Figure 32, page 34 for R/R Cascade system piping.

NOTICE

To avoid potential contamination of the boiler piping and heat exchangers. Install optional strainer kit, PSCAS24 on the system return piping to boilers in any R/R Cascade application (with or without boiler valves).

Individual Boiler or Cascade Kit P/N	Total Output MBH	System Temperature Difference (F)								
		20			30			40		
		GPM	Iron Pipe Size	ΔP/100 Feet	GPM	Iron Pipe	ΔP/100 Feet	GPM	Iron Pipe	ΔP/100 Feet
Solo 250	223	22	1.5”	3.4	15	1.25”	3.5	11	1.25”	2.0
Solo 399	379	38	2”	2.8	25	1.5”	4.2	19	1.5”	2.6
C(PS or RR)500	446	45	2”	3.5	30	2”	1.8	22	1.5”	3.4
C(PS or RR)800	758	76	3”	1.4	51	2.5”	1.9	38	2”	2.8
C(PS or RR)1000	892	89	3”	1.9	59	2.5”	2.5	45	2”	3.5
C(PS or RR)1200	1,138	114	4”	0.8	76	3”	1.4	57	2.5”	2.5
C(PS or RR)1600	1,518	152	4”	1.4	101	3”	2.5	76	3”	1.4
C(PS or RR)2000	1,897	190	4”	2.1	126	4”	1.0	95	3”	2.2

Table 9: Minimum Recommended System Iron Pipe Size and Pressure Drop/100 Feet of Pipe

Fitting or Valve			Iron Pipe Size							
			1.25	1.5	2	2.5	3	4	5	6
90° Elbow	Threaded	Machined	6.6	7.4	8.5	9.3	11	13		
		Cast					9	11		
	ANSI Flanged	Machined	2.1	2.4	3.1	3.6	4.4	5.9	7.3	8.9
		Cast					3.6	4.8		7.2
90° Elbow Long Radius	Threaded	Machined	3.2	3.4	3.6	3.6	4	4.6		
		Cast					3.3	3.7		
	ANSI Flanged	Machined	2.0	2.3	2.7	2.9	3.4	4.2	5	5.7
		Cast					2.8	3.4		4.7
45° Elbow	Threaded	Machined	1.7	2.1	2.7	3.2	4	5.5		
		Cast					3.3	4.5		
	ANSI Flanged	Machined	1.1	1.3	1.7	2	2.6	3.5	4.5	5.6
		Cast					2.1	2.9		4.5
Tee - Line Flow	Threaded	Machined	4.6	5.6	7.7	9.3	12	17		
		Cast					9.9	14		
	ANSI Flanged	Machined	1.3	1.5	1.8	1.9	2.2	2.8	3.3	3.8
		Cast					1.9	2.2		3.1
Tee - Branch Flow	Threaded	Machined	8.7	9.9	12	13	17	21		
		Cast					14	17		
	ANSI Flanged	Machined	4.4	5.2	6.6	7.5	9.4	12	15	18
		Cast					7.7	10		15
Globe Valve	Threaded	Machined	37	42	54	62	79	110		
		Cast					65	86		
	ANSI Flanged	Machined	54	59	70	77	94	120	150	190
		Cast					77	99		150
Gate Valve	Threaded	Machined	1.1	1.2	1.5	1.7	1.9	2.5		
		Cast					1.6	2		
	ANSI Flanged	Machined			2.6	2.7	2.8	2.9	3.1	3.2
		Cast					2.3	2.4		2.6
Swing Check	Threaded	Machined	13	15	19	22	27	38		
		Cast					22	31		
	ANSI Flanged	Machined	10	12	17	21	27	38	50	63
		Cast					22	31		52
Coupling	Machined		0.4	0.4	0.5	0.5	0.5	0.7		
	Cast						0.4	0.5		
Union	Machined		0.4	0.4	0.5	0.5	0.5	0.7		
	Cast						0.4	0.5		

Table 10: Equivalent Length of Straight Pipe

High Pressure Systems or Involving Fluid Separation

A heat exchanger is required between the Cascade and the system piping as shown in Figure 33, page 35 when operating under the following conditions:

- Standard 30 PSI Cascade - System operating pressure greater than 30 PSI.
- High Pressure (HP) 80 PSI Cascade - System operating pressure greater than 80 psi.
- Any Cascade requiring fluid separation (glycol from water)

NOTICE

For applications involving multiple Cascade configuration as shown in Figure: 33, page 35 in conjunction with a system heat exchanger contact Triangle Tube Technical Support for assistance in sizing heat exchanger and piping recommendations.

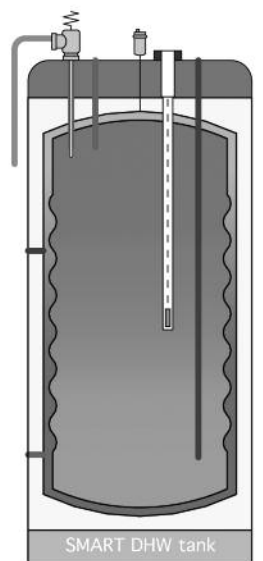
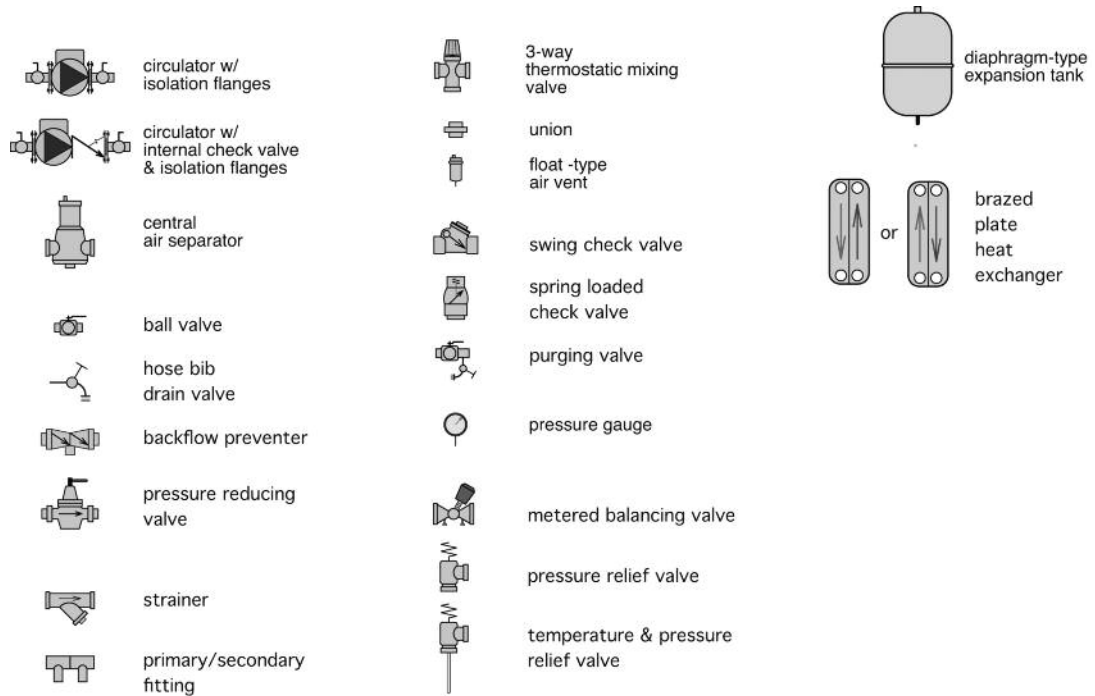

SMART Indirect water heater
(w/ trim)

Fig. 28 : System Piping Component Symbols

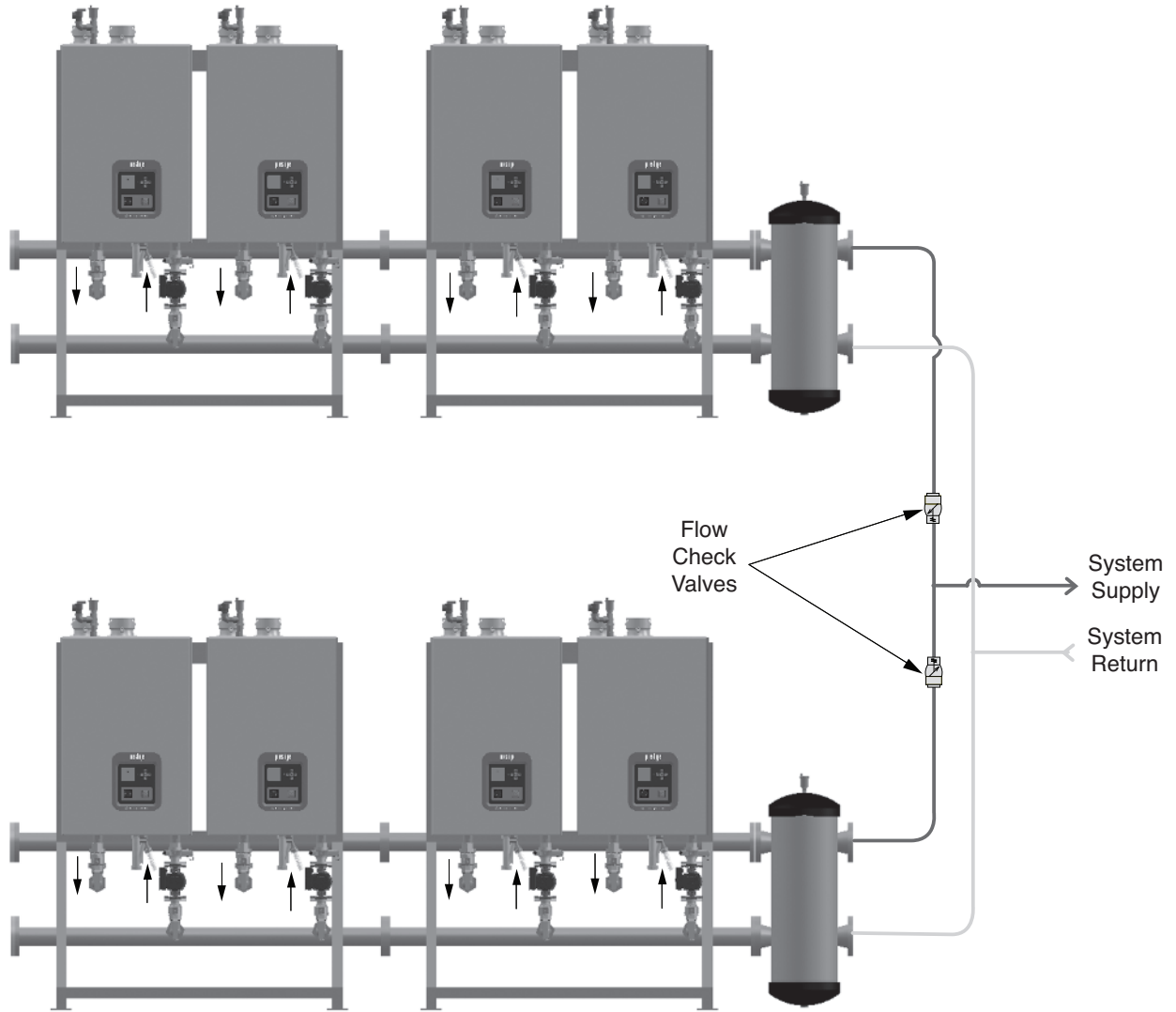

Fig. 29: System Piping - Cascade P/S with Banks of Equal Number of Boilers

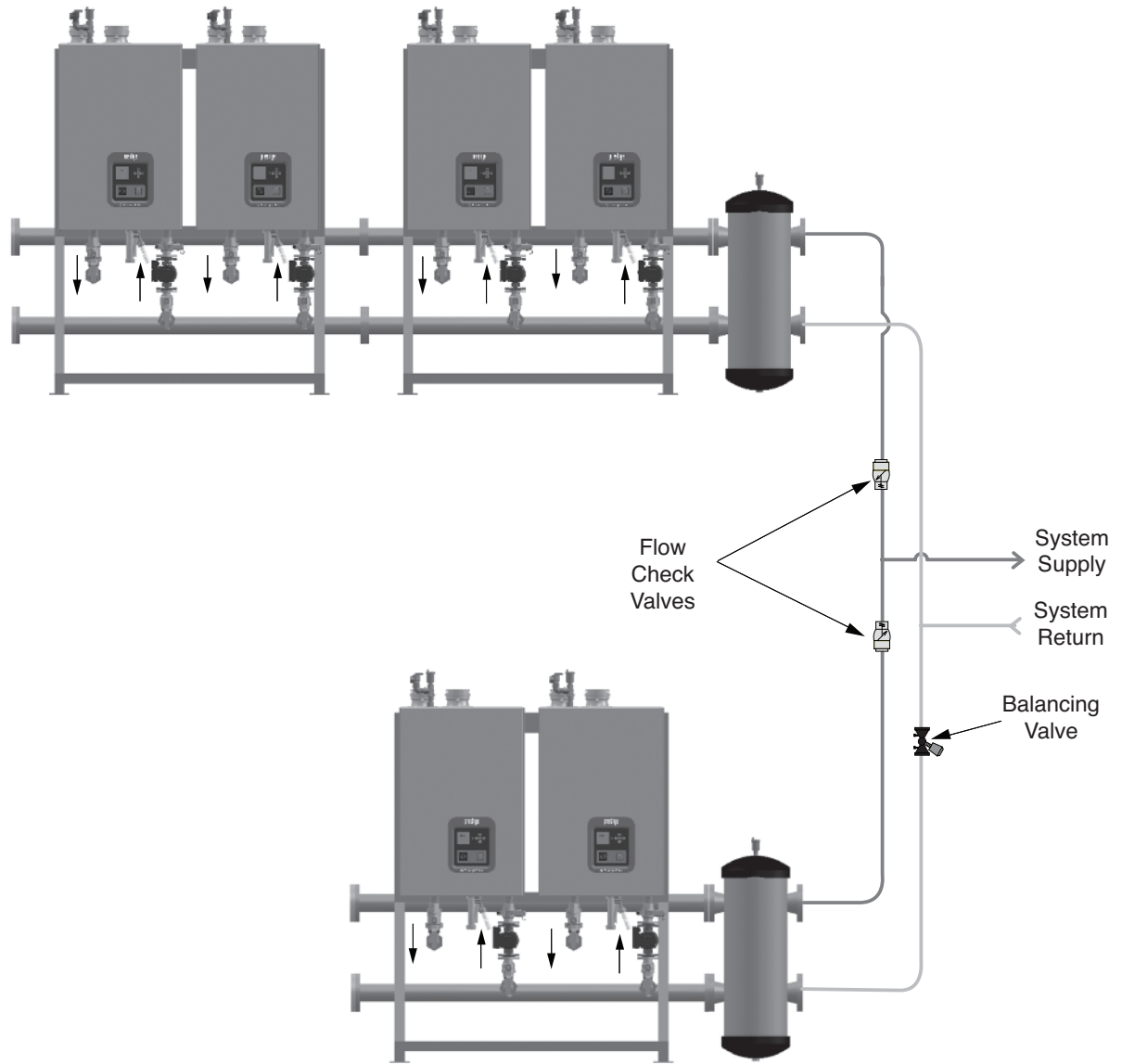

Fig. 30: System Piping – Cascade P/S with Banks of Uneven Number of Boilers

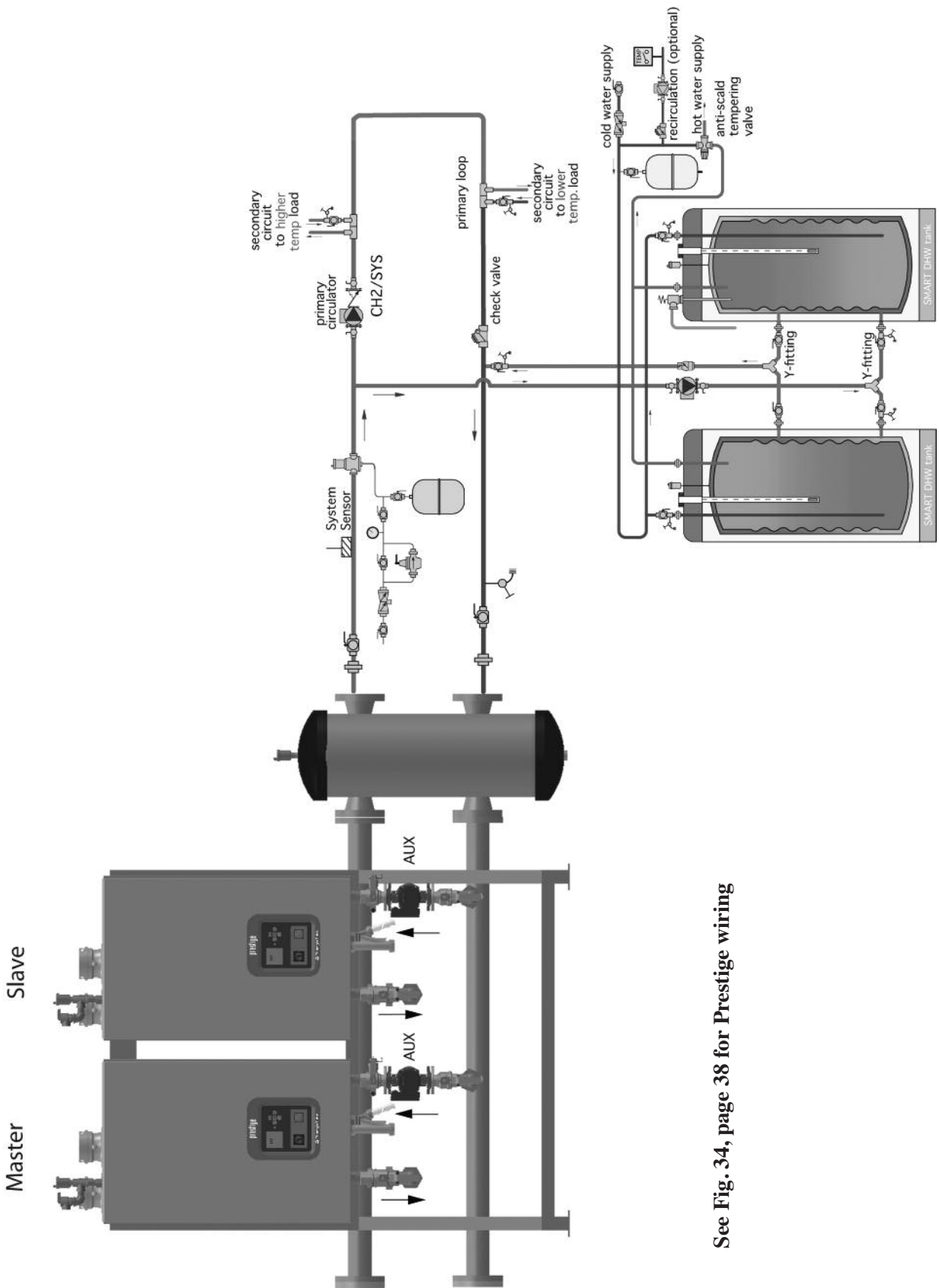
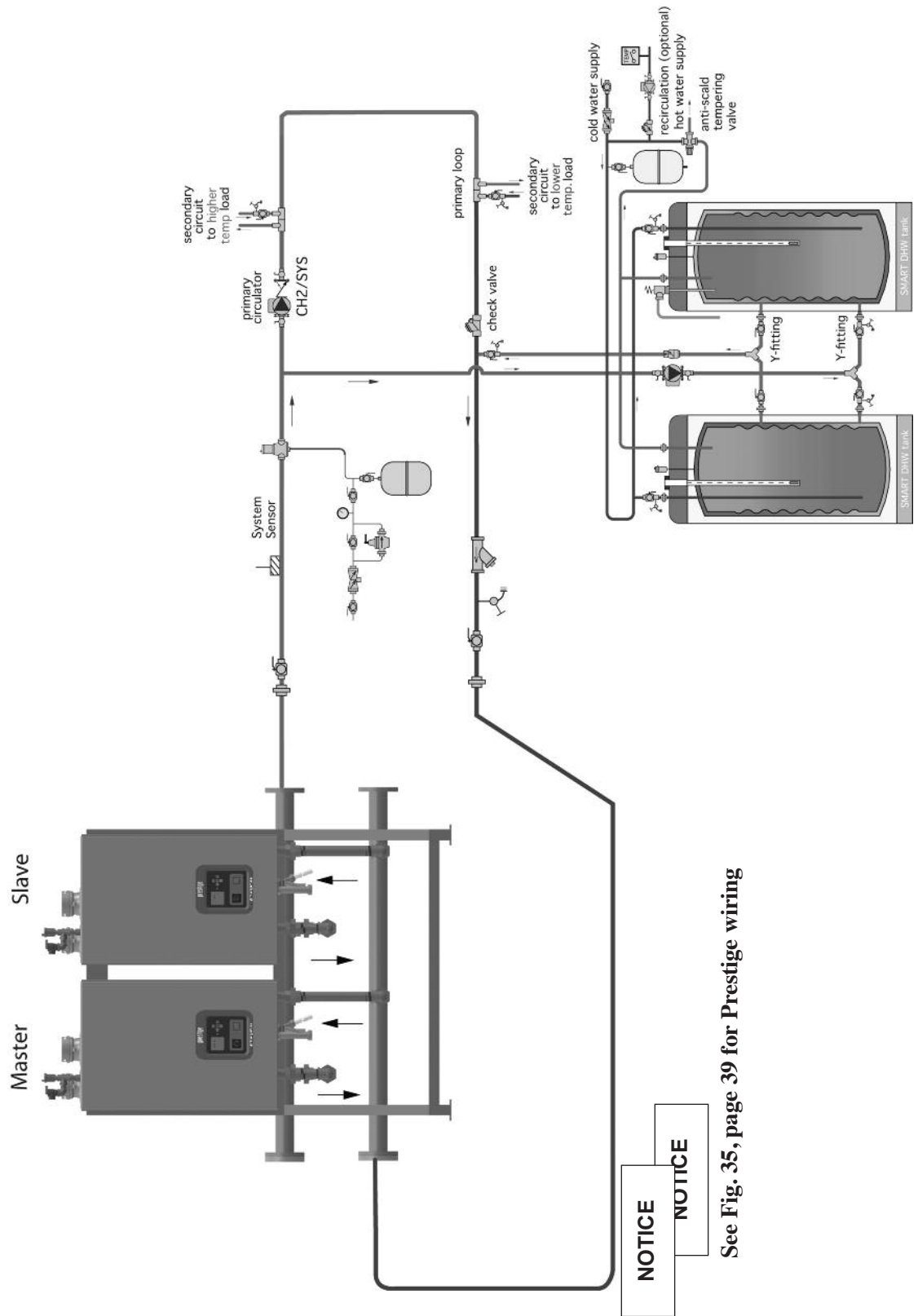

Fig. 31: System Piping – Cascade P/S

See Fig. 34, page 38 for Prestige wiring



See Fig. 35, page 39 for Prestige wiring

Fig. 32: System Piping – Cascade R/R

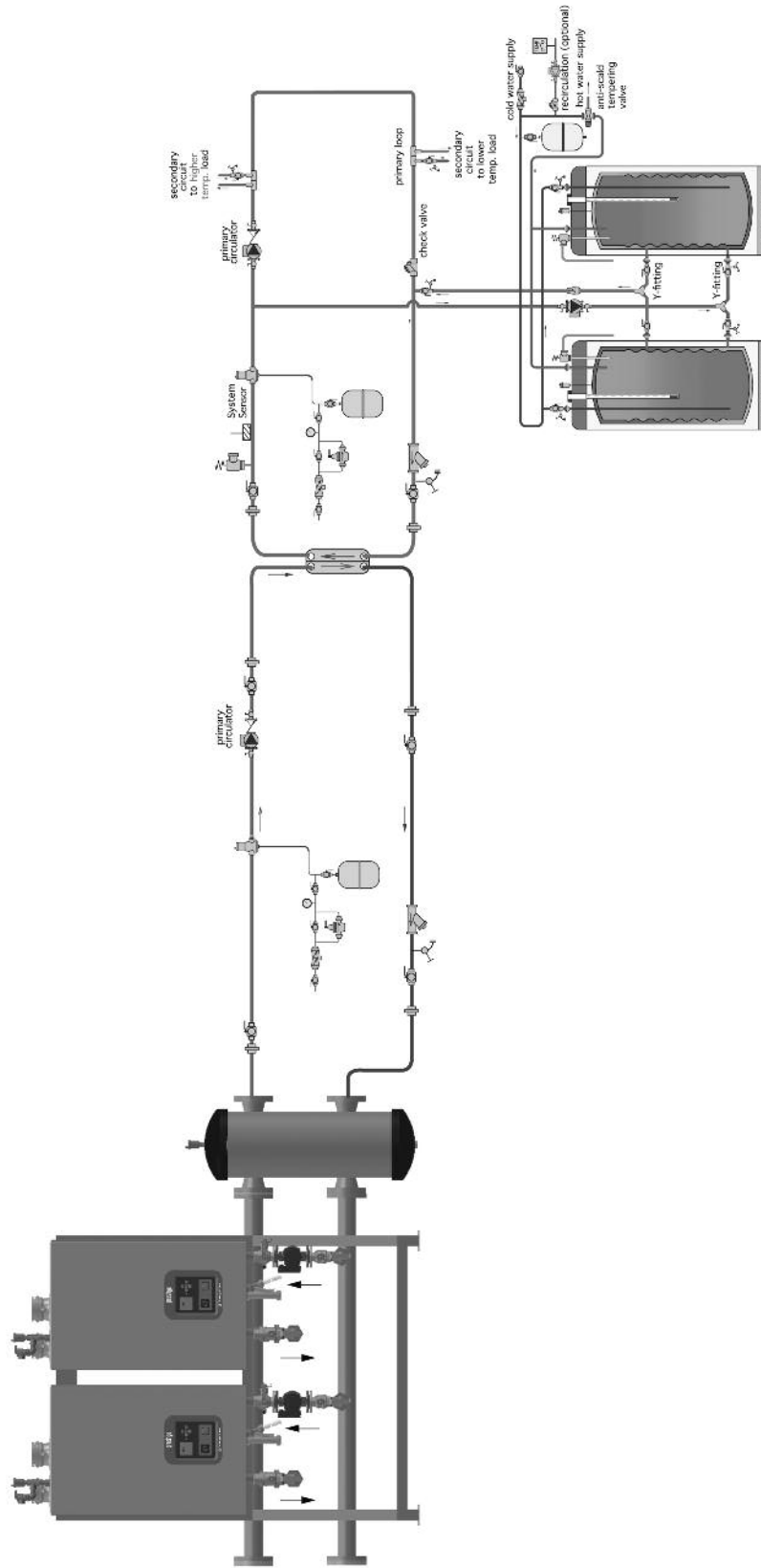

Fig. 33: System Piping – High Pressure Systems or Involving Fluid Separation

SECTION VII – GAS PIPING

Natural Gas - Pipe Sizing

Refer to Table 11 for Schedule 40 metallic pipe length and diameter requirements for natural gas, based on the total of all PRESTIGE Solo Boiler inputs (divided by 1,000 to obtain cubic feet per hour required).

- Table 11 is based on Natural Gas with a specific gravity of 0.60 and a pressure drop through the gas piping of 0.30”w.c.

- For additional gas piping sizing information, refer to ANSI Z223.1. For Canadian installations refer to CAN/CSA B149.1.

Propane Gas - Pipe Sizing

Contact the local propane gas supplier for recommended sizing of piping, tanks and 100% lockup gas regulator.

Length of Pipe in Feet	Capacity of Schedule 40 Metallic Pipe in Cubic Feet of Natural Gas Per Hour (based on 0.60 specific gravity, 0.30" w.c. pressure drop)					
	SCH 40	1-1/4"	1-1/2"	2"	2-1/2"	3"
10		1060	1580	3050	4860	8580
20		726	1090	2090	3340	5900
30		583	873	1680	2680	4740
40		499	747	1440	2290	4050
50			662	1280	2030	3590
75			533	1024	1637	2895
100				877	1400	2470
150				704	1120	1980
200				602	960	1700
250				534	851	1500
300					771	1360
400					660	1170
500					585	1030
600					530	937
700						862
800						802

Table 11: Gas Piping Sizing – Natural Gas

 = Not applicable for multiple Solo 399 Boilers

SECTION VIII – WIRING**Power Supply**

A dedicated 120 VAC/15A minimum service must be used to power the boilers in the Cascade System. Multiple boilers in the Cascade System can be placed on the same electrical circuit. Each boiler can draw a maximum of 8 amps.

Multiple Boiler Control

The TriMax Boiler Management System includes a cascade function which allows up to six Prestige boilers to operate together in a single heating system. Consult the Prestige TriMax Control Supplement for more information on the built in cascade function. If necessary to control more than six boilers, Triangle Tube's Optima SCC4 (PSCON03) and SCC4 Extension Modules (PSCON04) can be used to control up to sixteen boilers. Contact Triangle Tube Technical Support for more information regarding Triangle Tube's Optima Series of Multiple Boiler Controls.

The TriMax Boiler Management System includes the ability to communicate with building management systems (BMS) through a Modbus interface. Building management system gateways are also available for BACnet® and LonWorks® systems. Consult the Prestige TriMax Control Supplement for more information.

CSD-1 P/S or R/R with Valve Kit

1. A high limit control and a low water cut off are required for each boiler and should be wired to terminals 9 & 10 of the boiler terminal strip, see Figure 34, page 38.
2. Ensure wiring to terminals 9 & 10 utilize a dry set of contacts with no power (24V or 120V) being brought back or taken from the terminals on the boiler.
3. When wiring to terminals 9 & 10, an open set of contacts will result in an E87 External Limit Open hard lock out for that individual boiler.
4. While in a hard lock out condition the auxiliary boiler pump & CH(1) pump wired to the boiler will be energized.
5. To reset the boiler the condition will need to be corrected and then the boiler will need to be reset.

CSD-1 R/R

1. A single high limit control and low water cut off control for the Cascade system can be wired to each boiler through an isolation relay. A dry contact input relay is included with the common vent system and can be used for all external limits. See Fig. 35, page 39. If the common vent system is not being utilized, each boiler will require a 120 VAC coil relay with a normally open contact. See Fig. 35A, page 40.
2. Ensure wiring to terminals 9 & 10 utilize a dry set of contacts with no power (24V or 120V) being brought back or taken from the terminals on the boiler.
3. When wiring to terminal 9 & 10 an open set of contacts will result in an E87 External Limit Open hard lock out.
4. To reset the boilers the condition will need to be corrected and then each boiler will need to be reset.

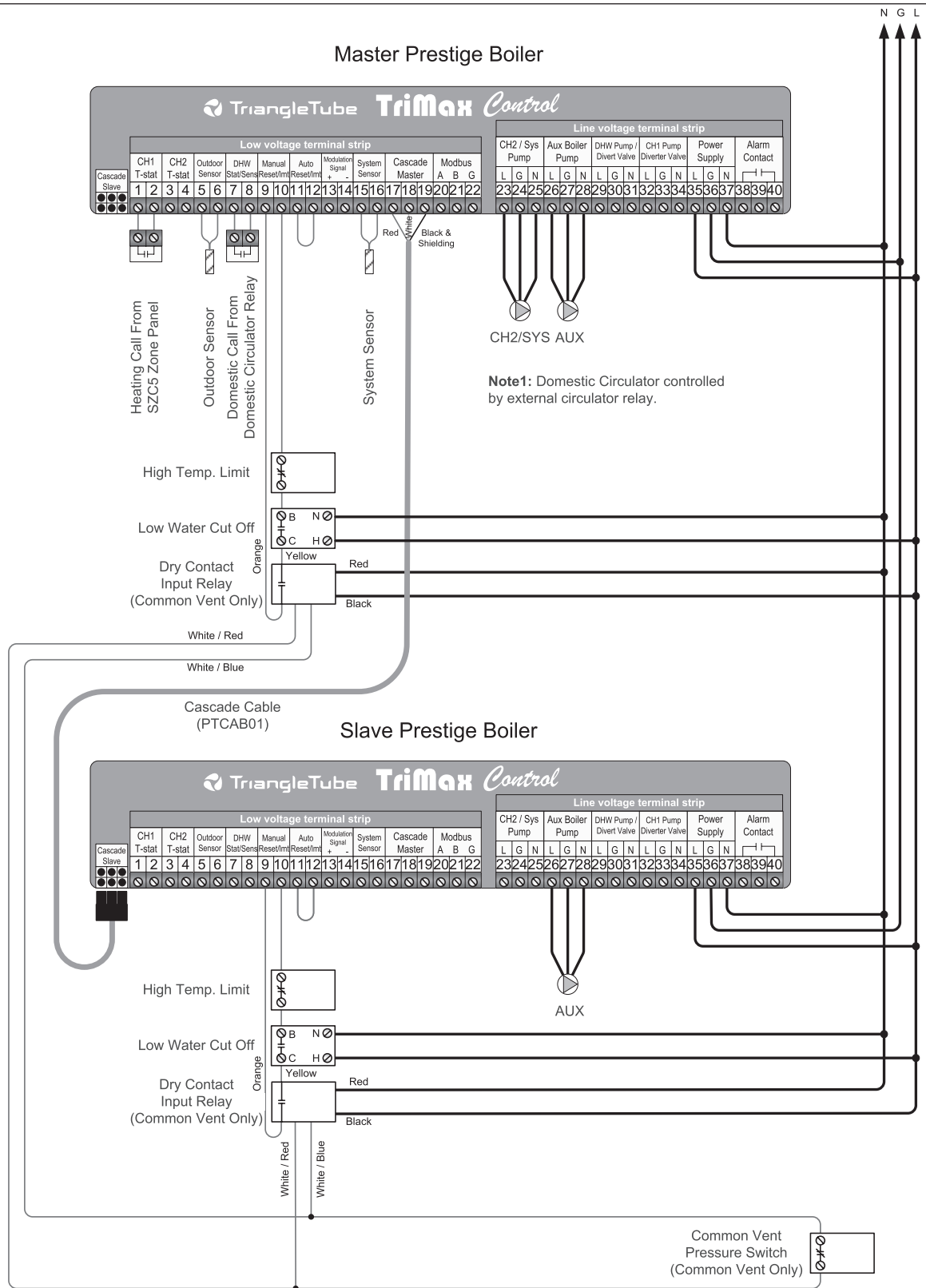

NOTES:

1. This drawing shows system wiring concept only
2. Installer is responsible for all equipment & detailing required by local codes
3. All wiring shall be in conformance with the latest edition of the National Electrical Code
4. Do not run sensor wiring in same conduit or raceway as line voltage wiring
5. Use 18 AWG copper twisted pair wiring for all sensor wiring

NOTICE

See Fig. 31, page 33 for System Piping

Fig. 34: Wiring Diagram - Individual LWCO & High Limit Per Boiler

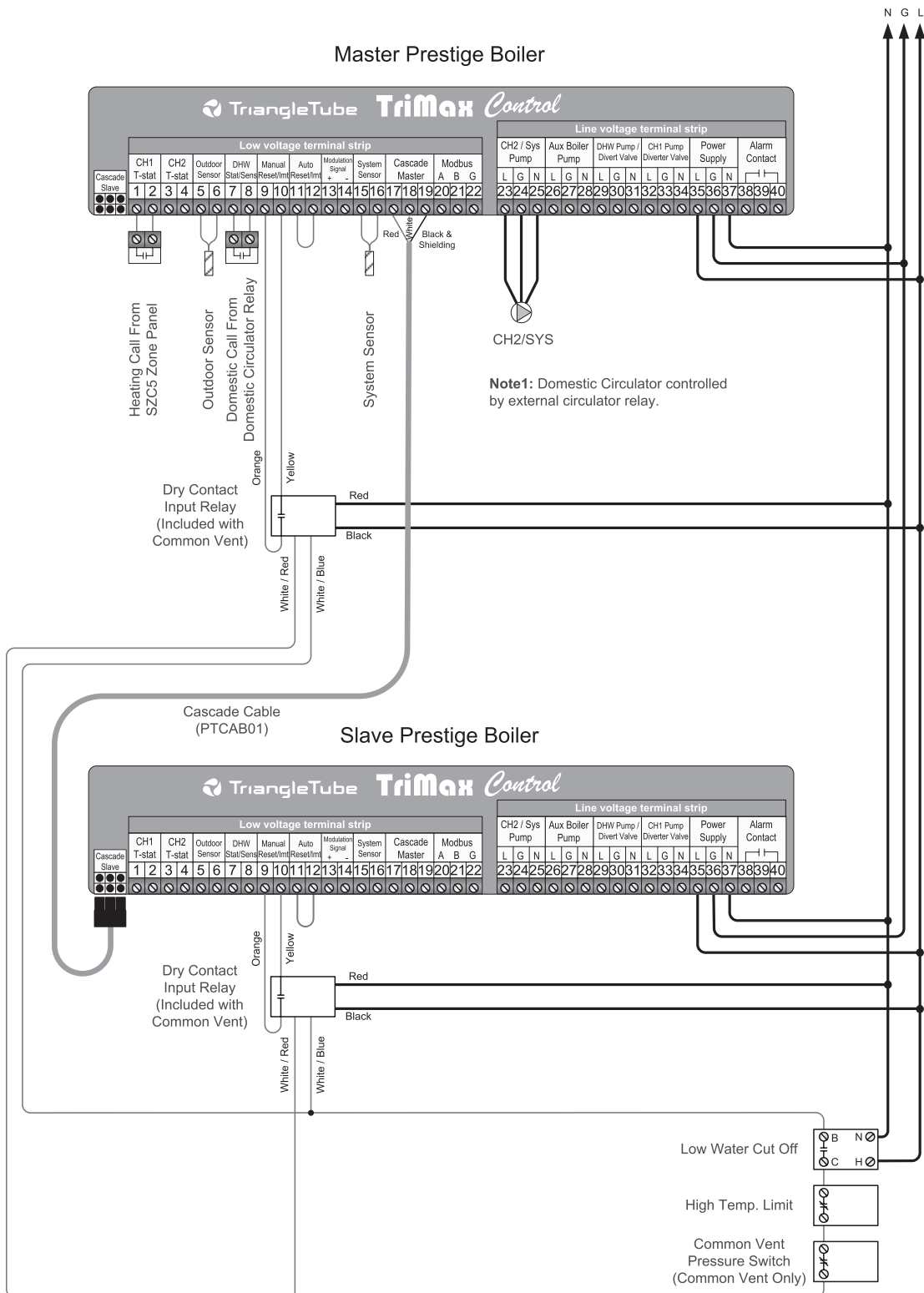

NOTES:

1. This drawing shows system wiring concept only
2. Installer is responsible for all equipment & detailing required by local codes
3. All wiring shall be in conformance with the latest edition of the National Electrical Code
4. Do not run sensor wiring in same conduit or raceway as line voltage wiring
5. Use 18 AWG copper twisted pair wiring for all sensor wiring

NOTICE

See Fig. 32, page 34 for System Piping

Fig. 35: Wiring Diagram – One LWCO & High Limit Per Cascade with Common Vent

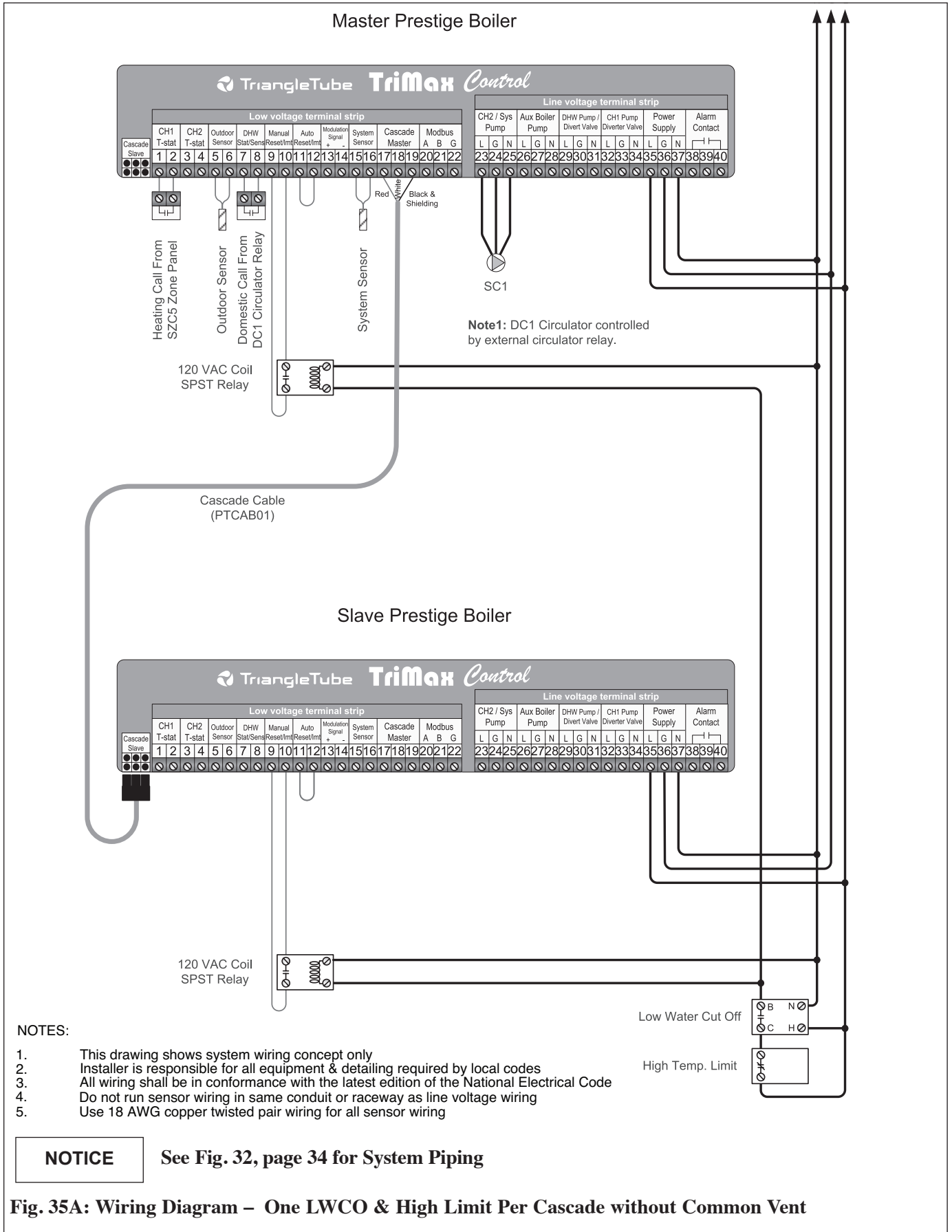

SECTION IX - SYSTEM START-UP

Check System Water Chemistry

⚠ WARNING

Do not use petroleum-base cleaning or sealing compounds in the boiler system. Damage to seals and gaskets in the system components could occur, resulting in substantial property damage.

NOTICE

System water including additives must be practically non-toxic, having a toxicity rating or Class of 1, as listed in Clinical Toxicology of Commercial Products.

Water pH Level 6.0 to 8.0

Maintain the water pH between 6.0 and 8.0. Check using litmus paper or contact a water treatment company for a chemical analysis.

If the pH does not meet this requirement, do not operate the Cascade or leave the system filled until the condition is corrected.

Water Hardness Less Than 7 Grains

For areas with unusually hard water (hardness above 7 grains) consult a water treatment company.

Chlorinated Water

Do not use the Cascade to heat a swimming pool or spa directly.

Maintain the chlorine level of the water at levels considered safe for drinking.

Flush System to Remove Sediment

The installer must flush the system to remove any sediment to allow proper operation.

Flush the systems until the water runs clean and is free of sediment.

For zoned systems, each zone should be flushed through a purge valve. Purge valves and isolation valves should be installed on each zone to allow proper flushing of the system.

Use of Antifreeze in the System

⚠ WARNING

NEVER use automotive or ethylene glycol antifreeze or undiluted antifreeze in the primary system as freeze protection. This can cause severe personal injury, death or substantial property damage if ignored.

Determine the antifreeze fluid quantity using the system water content volume and following the antifreeze manufacturer instructions.

Consult product specifications page 56 for the Cascade water volume.

Check with local codes requirements for the installation of backflow preventers or actual disconnection from the boiler’s cold water fill or make up water supply line.

NOTICE

Massachusetts Code requires the installation of a backflow preventer if antifreeze is used.

Ensure the concentration of antifreeze to water does not exceed a 50/50 ratio.

NOTICE

System water, including additives, must be practically non-toxic, having a toxicity rating or Class of 1, as listed in Clinical Toxicology of Commercial Products.

Check and Test Antifreeze

For systems containing antifreeze solutions, follow the antifreeze manufacturer's instructions in verifying the inhibitor level and to ensure the fluid characteristics are within specification requirements.

Due to the degradation of inhibitors over time, antifreeze fluids must be periodically replaced. Refer to the manufacturer of the antifreeze for additional instructions.

<i>NOTICE</i>

System water including additives must be practically non-toxic, having a toxicity rating or Class of 1, as listed in Clinical Toxicology of Commercial Products.

SECTION X - MAINTENANCE SCHEDULE

Service Technician

At least on an annual basis the following maintenance should be performed by a qualified service technician:

General

- Attend to any reported problems.
- Check for leaks: water.
- Check water pressure, piping and expansion tank.

Once the maintenance items are completed, review the service with the owner.

Owner Maintenance

Periodically:

- Check the area around the unit.
- Check the temperature and pressure gauges.

Monthly:

- Check the pressure relief valve.

Every 6 months:

- Check piping for corrosion or potential signs of leakage.
- Operate the pressure relief valve.



Follow the maintenance procedures given throughout this manual. Failure to perform the service and maintenance or follow the directions in this manual could result in damage to the Cascade or in system components, resulting in severe personal injury, death or substantial property damage.

SECTION XI - MAINTENANCE PROCEDURES

Maintenance Procedures

WARNING

The Cascade should be inspected and serviced annually, preferably at the start of the heating season, by a qualified service technician. In addition, the maintenance as further explained should be performed to assure reliability.

NOTICE

The following information provides detailed instruction for completing the maintenance items outline in the maintenance schedule. In addition to this maintenance, the Cascade should be serviced at the beginning of the heating season by a qualified service technician.

Reported Problems

Any problems reported by the owner should be checked, verified and corrected before proceeding with any maintenance procedures.

Check Surrounding Area

Verify that the area surrounding the Cascade is free of combustible / flammable materials or flammable vapors or liquids. Remove immediately if found.

Check System Piping

Inspect water piping on the Cascade system for leaks and verify that the piping is leak free and properly supported.

Inspect the fittings and components on the unit and verify they are leak free.

WARNING

Eliminate all boiler water system leaks. Continual fresh make-up water will reduce the heat exchanger life causing boiler failure. Leaking water may also cause severe property damage to the surrounding area.

Check Boiler/ Cascade System

Verify all system components are correctly installed and operating properly.

Check the cold fill pressure for the system, typical cold water fill pressure is 12 psig.

Verify the system pressure, as the unit operates at high temperature, to ensure the pressure does not exceed 25 psig (Standard Cascade) or 75 psig (High Pressure (HP) Cascade). Excessive pressure reading indicates expansion tank sizing is incorrect or system performance problems.

Inspect air vent and air separators in the system. Remove the caps on automatic air vents and briefly depress the valve stem to flush vent. Replace the cap when completed. Ensure vents do not leak, replace any leaking vents.

Check Expansion Tank

Refer to Section VI - System Piping for recommended location of the expansion tank and air elimination devices.

Closed -Type Tank:

- Ensure tank is partially filled with water leaving an air gap as a cushion. Refer to the manufacturer's instruction for proper fill level.
- Ensure the tank is fitted with a device that reduces gravity circulation of air-saturated tank water back into the system. This device prevents air from bubbling up through the water as it returns from the system.
- Ensure no automatic air vents are used in the system. This will allow air to escape from the system instead of returning to the tank.

Diaphragm Tank:

- Ensure the system contains a minimum of one automatic air vent. Recommended location of the air vent should be atop an air elimination devices.
- Remove the tank from the system and check the charge pressure. The charge pressure is typically 12 psig. If tank does not hold a charge pressure, then the membrane is damaged and the tank should be replaced.

Check Boiler Relief Valve

Inspect the relief valve and lift the lever to verify flow at least annually or as recommended on the warning tag of the valve.

 **WARNING**

Before manually operating the pressure relief valve, ensure the discharge piping is directed to a suitable place of disposal to avoid a potential scald hazard. The discharge piping must be full size without restriction and installed to permit complete drainage of both the valve and line.

If after closing the valve, the valve fails to seat properly or continually weeps, replace the relief valve. Ensure the cause of the relief valve to weep is the valve itself, not due to system over-pressurization caused by an expansion tank that is waterlogged or undersized.

Part #	Description
PSLWC01	Low Water Cut Off with Probe - 3/4" NPT x 2" Long Insertion
PSFLG03	Flange ANSI to 3" NPSC
PSFLG02	Flange ANSI to Blind
PSGK24	Gasket ANSI
PSNUT03	5/16" - 18 Nut - Flanged
PSBLT03	5/16" - 18 x 3" Bolt - Flanged
PSCON07	Manual High Limit - 200°F
PSWEL01	1/2" NPT x 1 1/2" Dry well for High Limit
PSCOM01	Heat Conductive Compound for High Limit

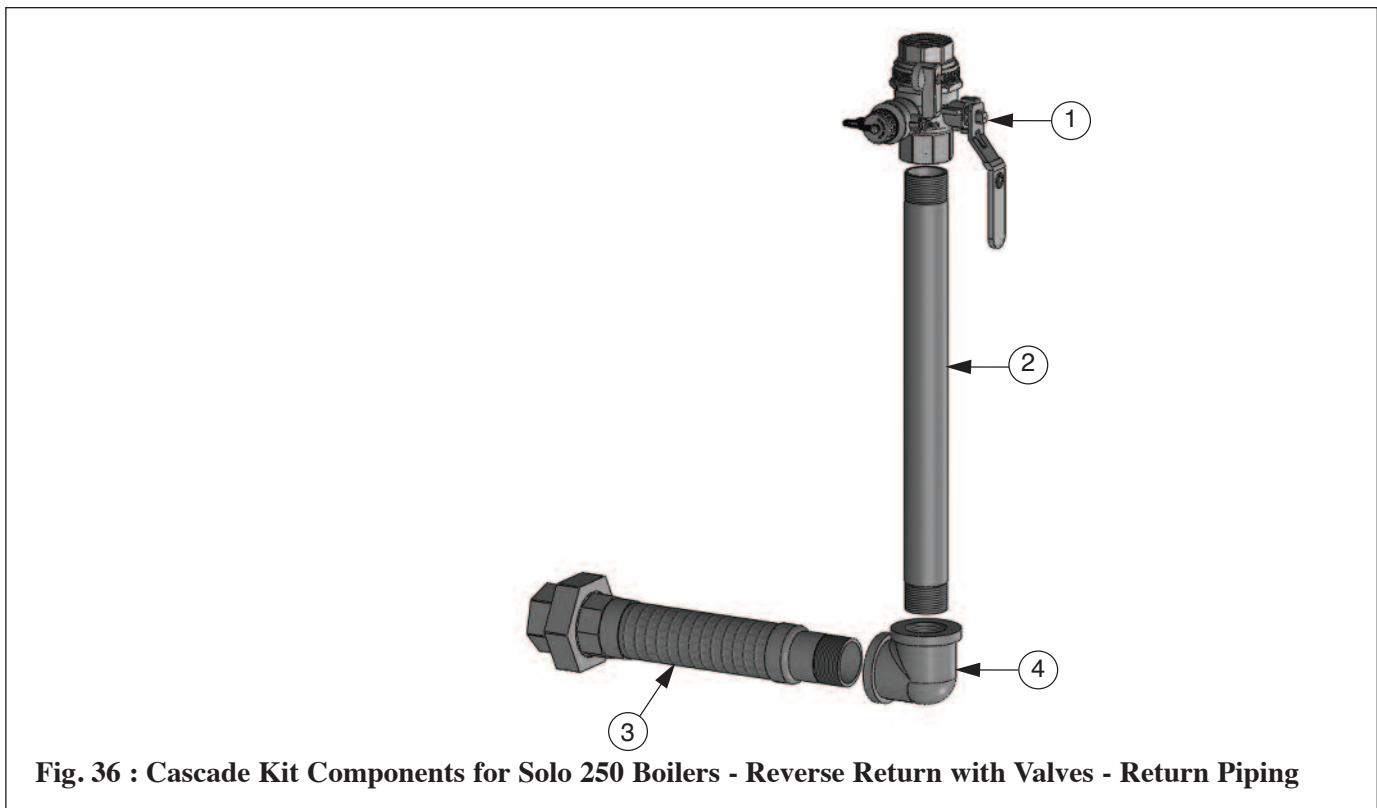

Fig. 36 : Cascade Kit Components for Solo 250 Boilers - Reverse Return with Valves - Return Piping

Item	Part #	Description
1	PSVLV13	1-1/4" NPT Union/Drain/Shut Off Valve Assembly
2	PSNIP11	1-1/4" NPT x 16" Pipe - RR with Valves
	PSNIP10	1-1/4" NPT x 18" Pipe - RR
3	PSHOS02	1-1/2" NPT x 13" Flexible Hose/Union Assembly
4	PSELB09	1-1/2" NPT x 1-1/4" NPT 90° Reducing Elbow



Fig. 37: Cascade Kit Components for Solo 250 Boilers - Primary Secondary Supply Piping

Item	Part #	Description
1	PSVLV11	1-1/2" NPT Union/Shut Off Valve Assembly
2	PSHOS02	1-1/2" NPT x 13" Flexible Hose/Union Assembly
3	PSELB09	1-1/2" NPT x 1 1/4" NPT 90° Reducing Elbow
4	PSTEE03	1-1/4" NPT x 1/2" NPT x 1 1/4" Inline Reducing Tee

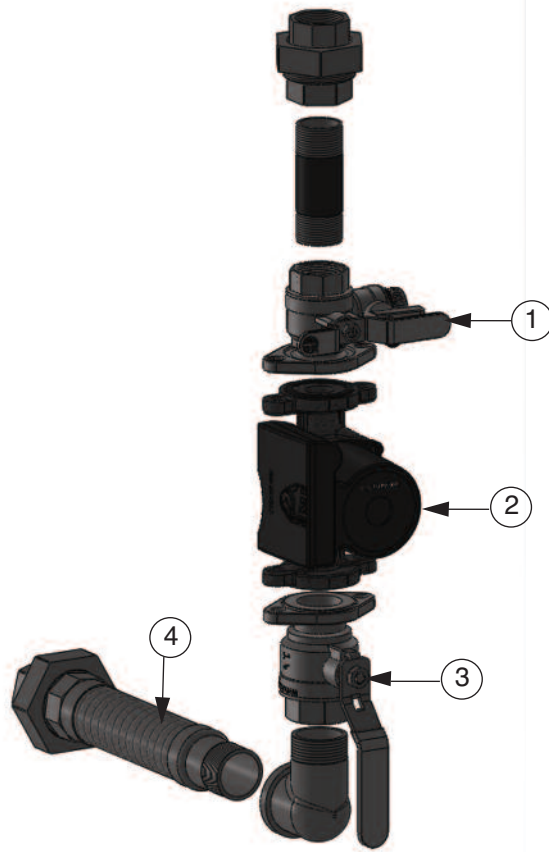

Fig. 38: Cascade Kit Components for Solo 250 Boilers - Primary/Secondary Return Piping

Item	Part #	Description
1	PSVLV14	1-1/4" NPT Drain/Shut-Off Valve/Circulator Flange Assembly
2	PSCIR02	Circulator - Grundfos UPS15-58
3	PSVLV10	1-1/2" NPT Circulator Flange/Shut Off Valve Assembly
4	PSHOS02	1-1/2" NPTx 13" Flexible Hose/Union Assembly

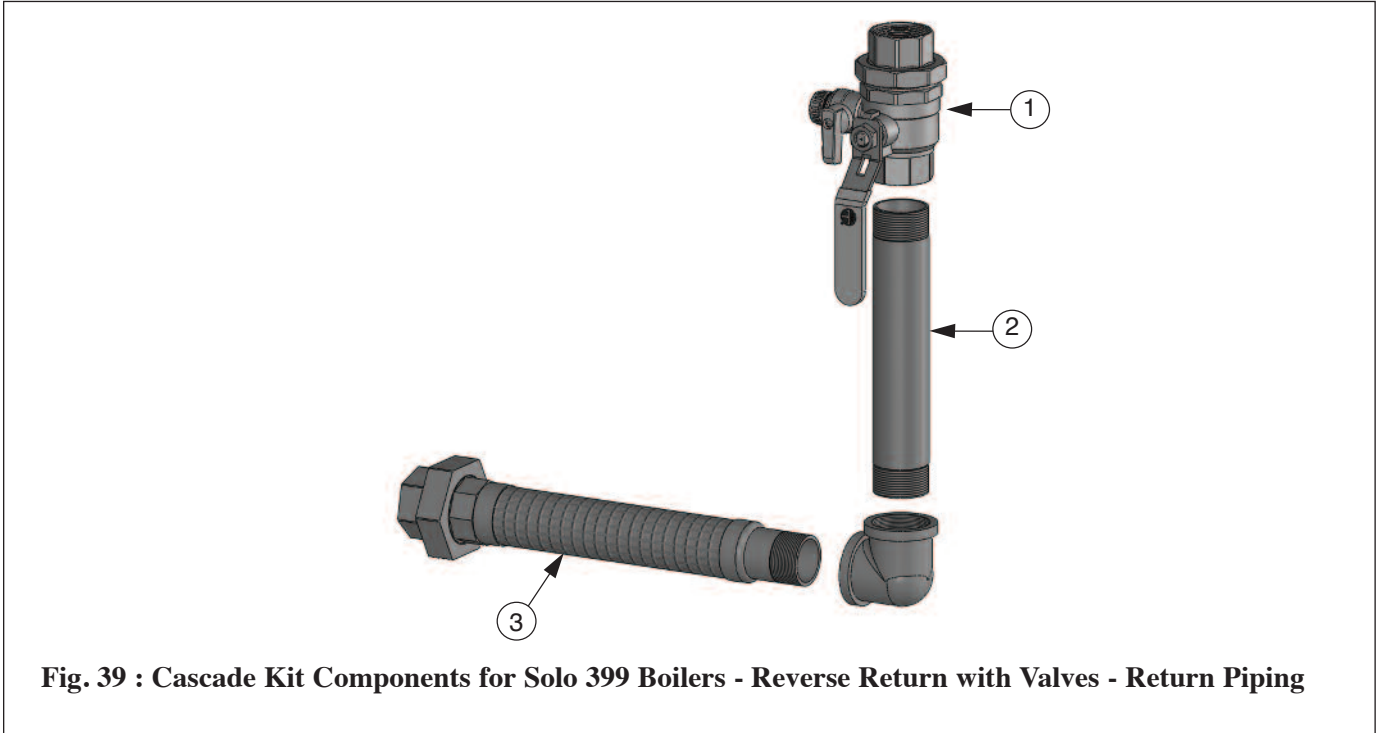

Fig. 39 : Cascade Kit Components for Solo 399 Boilers - Reverse Return with Valves - Return Piping

Item	Part #	Description
1	PSVLV12	1-1/2" NPT Union/Drain/Shut Off Valve Assembly
2	PSNIP07	1-1/2" NPT x 10" Pipe - RR with Valves
	PSNIP04	1-1/2" NPT x 13-1/2" Pipe - RR
3	PSHOS01	1-1/2" NPT x 15" Flexible Hose/Union Assembly

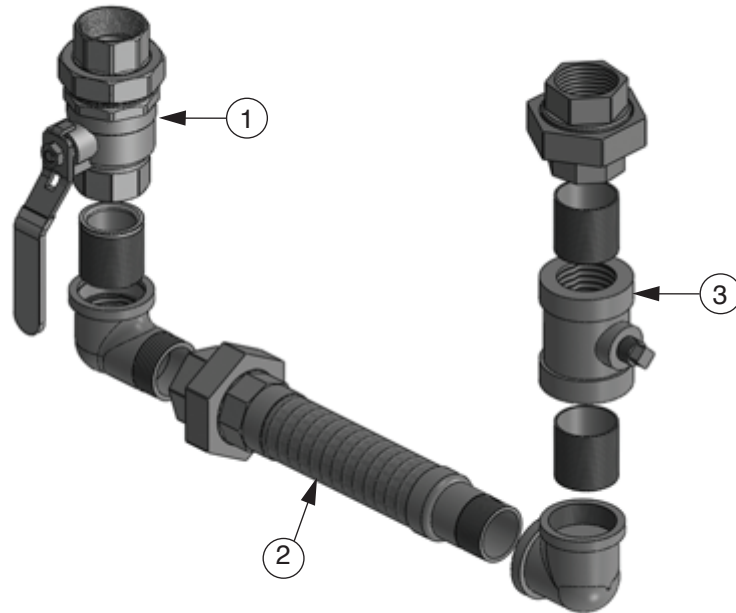

Fig. 40: Cascade Kit Components for Solo 399 Boilers - Primary Secondary Supply Piping

Item	Part #	Description
1	PSVLV11	1-1/2" NPT Union/Shut Off Valve Assembly
2	PSHOS01	1-1/2" NPT x 15" Flexible Hose/Union Assembly
3	PSTEE04	1-1/2" NPT x 1/2" NPT x 1-1/2" NPT Inline Reducing Tee



Fig. 41: Cascade Kit Components for Solo 399 Boilers - Primary/Secondary Return Piping

Item	Part #	Description
1	PSVLV09	1-1/2" NPT Drain/Shut-Off Valve/Circulator Flange Assembly
2	PSCIR01	Circulator - Grundfos UPS26-99FC
3	PSVLV10	1-1/2" NPT Circulator Flange/Shut Off Valve Assembly
4	PSHOS01	1-1/2" NPTx 15" Flexible Hose/Union Assembly

Part N°	"A"
CPS 500	86"
CPS 1000	154"

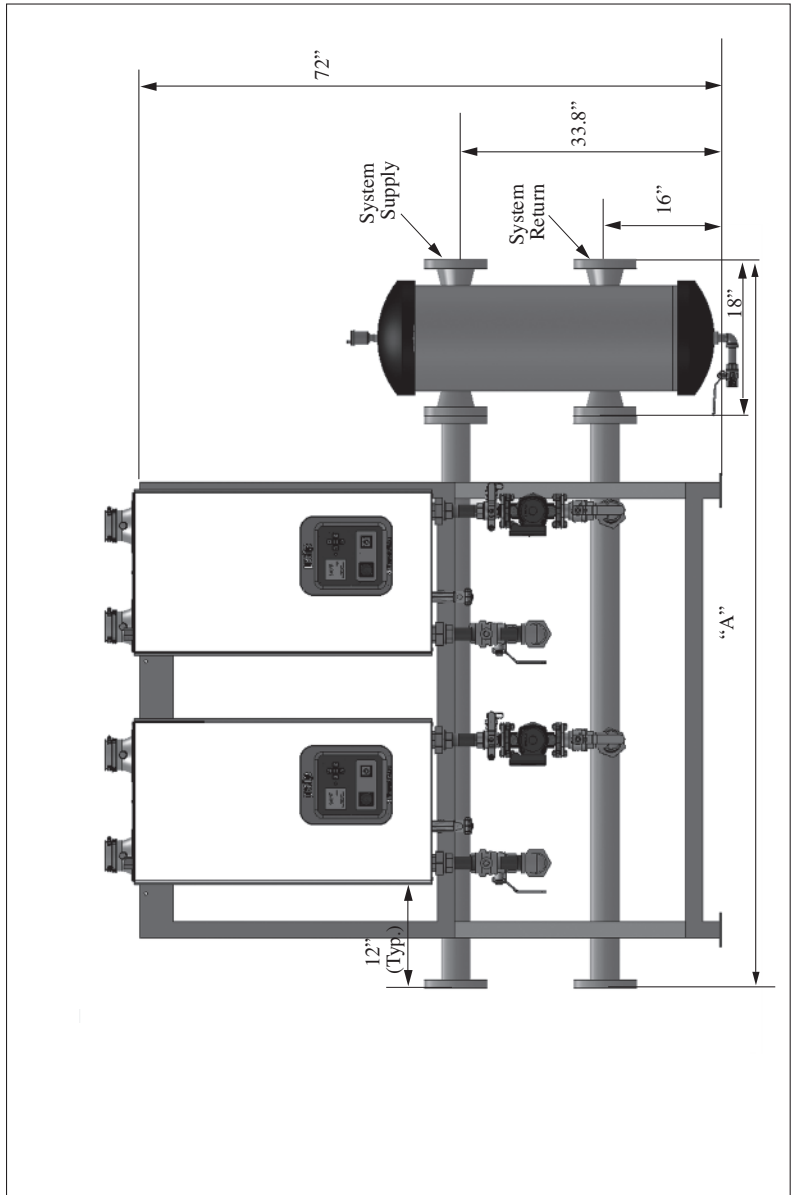
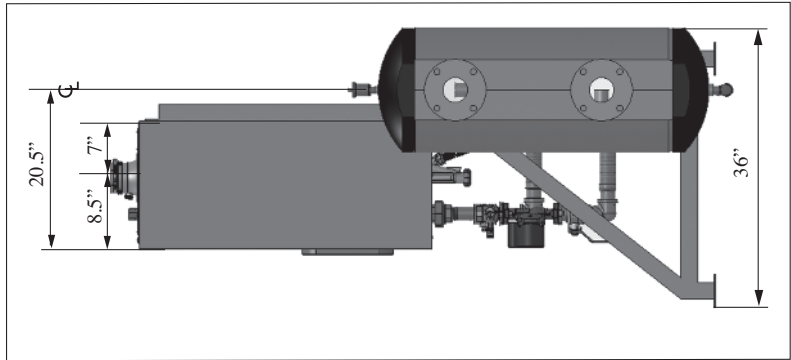
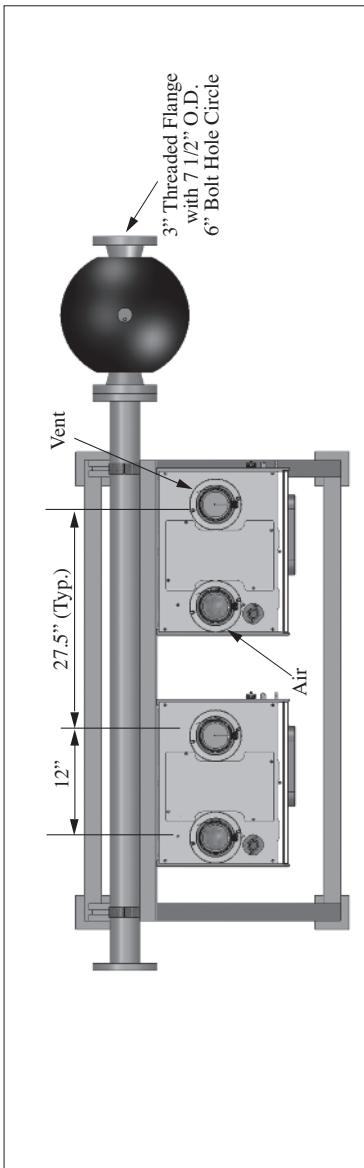

Fig. 42: Dimensions CPS for Solo 250 Boilers

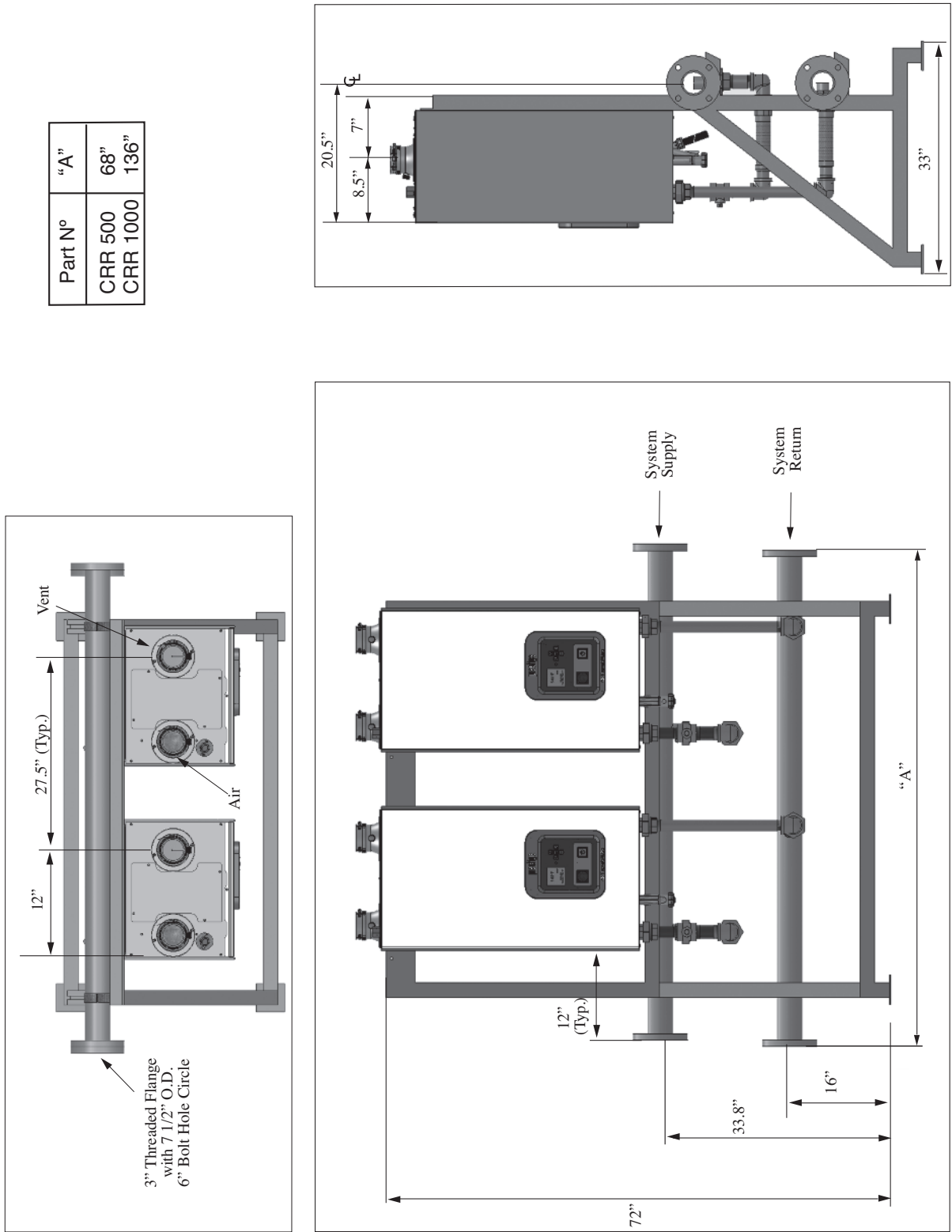

Fig. 43: Dimensions CRR for Solo 250 Boilers

Part No	"A"
CPS 800	86"
CPS 1200	113"
CPS 1600	154"
CPS 2000	181"

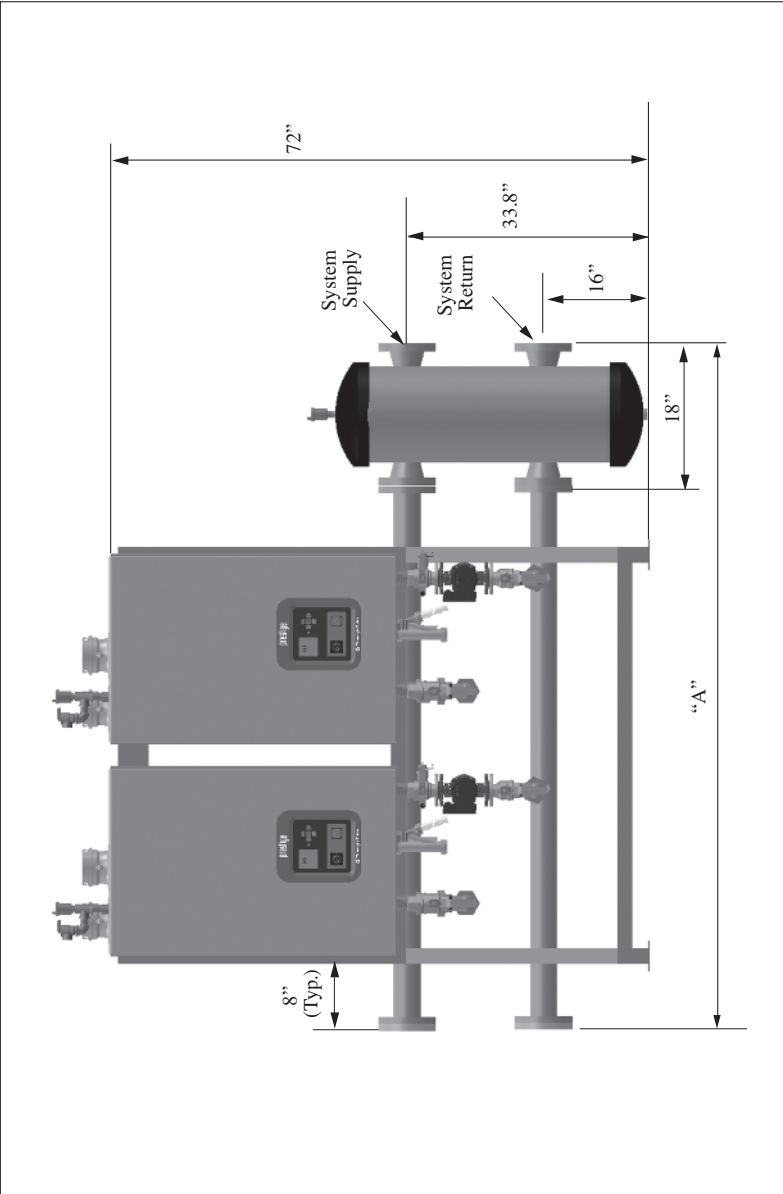
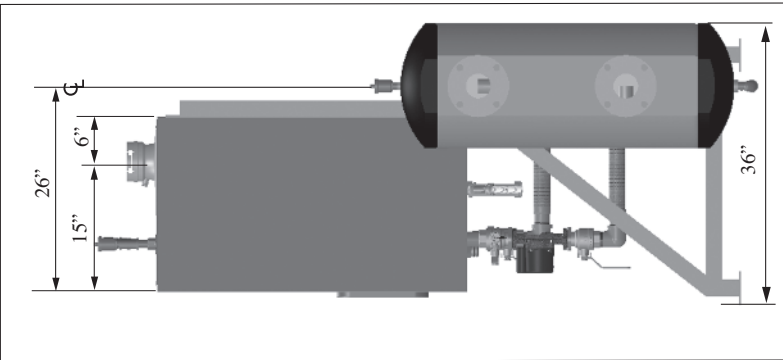
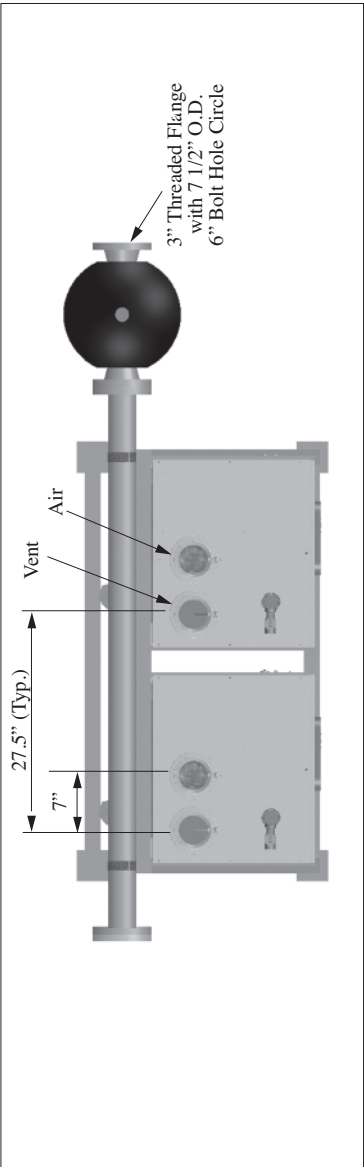

Fig. 44: Dimensions CPS for Solo 399 Boilers

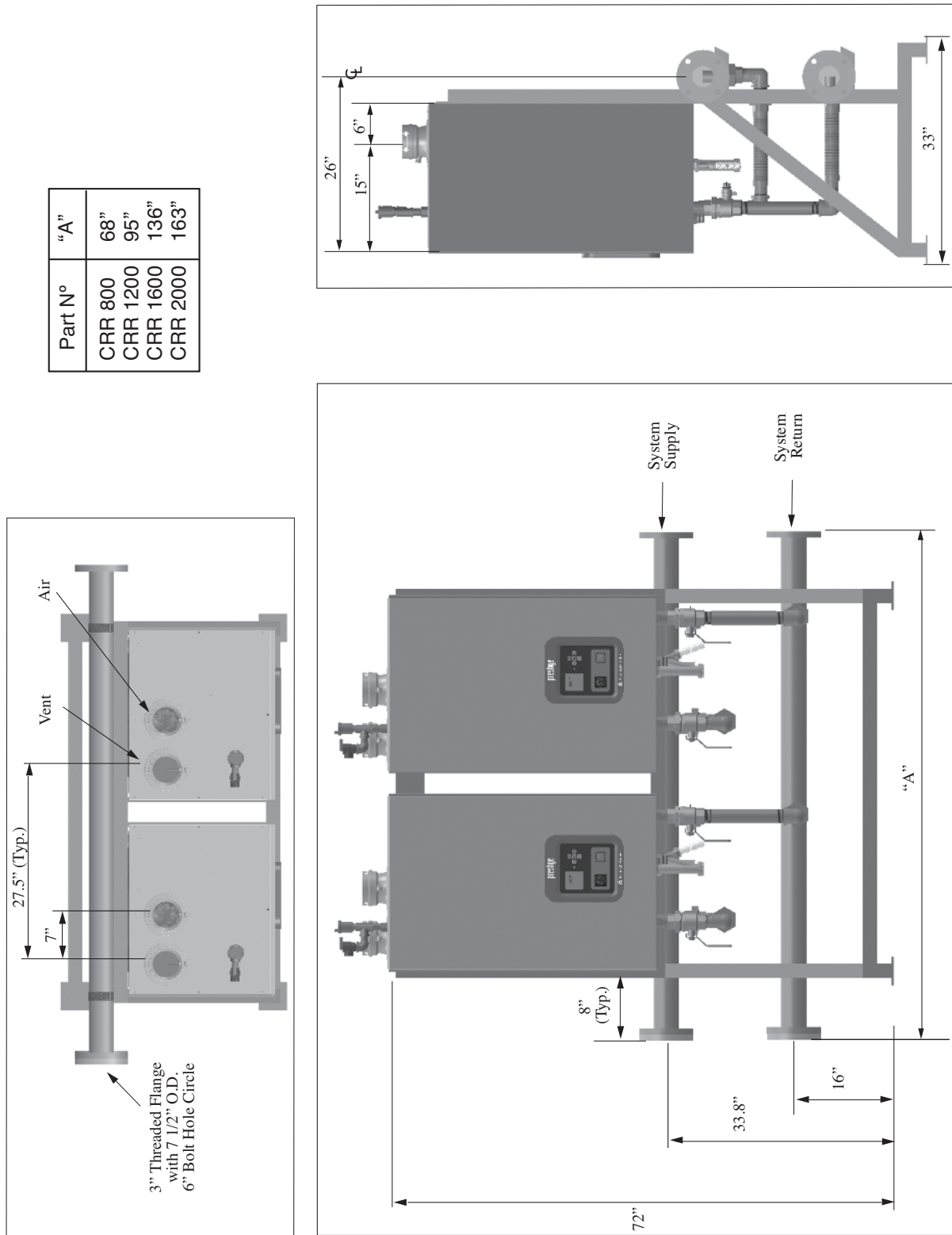

Fig. 45: Dimensions CRR for Solo 399 Boilers

Product Specifications

Cascade Kit P/N	# of Manifolds	# of Solo 250 or 399 Boilers	Total Input MBH Note 1	Total Output MBH Note 1 & 2	Total Net IBR Rating MBH Note 3	Total EDR Water Ft 2 Note 4	Total Output Boiler Horse-Power	Minimum Recommended System Iron Pipe Size Note 5	Minimum Recommended Natural Gas Header Size Note 6
C(PS or RR) 500	1	2 (250)	65 - 490	446	388	2,588	13.3	2"	2"
C(PS or RR) 800	1	2 (399)	112 - 798	758	659	4,396	22.6	3"	2"
C(PS or RR)1000	2	4 (250)	65 - 980	892	776	5,176	26.6	3"	2.5"
C(PS or RR)1200	1	3 (399)	112 - 1,197	1,138	990	6,603	34.0	4"	2.5"
C(PS or RR)1600	2	4 (399)	112 - 1,596	1,518	1,320	8,804	45.3	4"	3"
C(PS or RR)2000	2	5(399)	112 - 1,995	1,897	1,650	11,006	56.7	4"	3"

Component	Individual Water Content Gal	Individual Shipping Weight Lbs
Prestige 250	4.1	167
Prestige 399	7	225
2 Boiler Manifold	6.6	267
3 Boiler Manifold	9.3	326
Hydronic Junction	8	124

Cascade Kit P/N	Total Water Content Gal.	Total Shipping Weight Lbs
CPS 500	23	725
CPS 800	29	841
CPS 1000	38	1,326
CPS 1200	39	1,125
CPS 1600	50	1,558
CPS 2000	59	1,842

Cascade Kit P/N	Total Water Content Gal.	Total Shipping Weight Lbs.
CRR 500	15	601
CRR 800	21	717
CRR 1000	30	1,202
CRR 1200	31	1,001
CRR 1600	42	1,434
CRR 2000	51	1,718

Note1: Input and output ratings are shown for sea level applications. The PRESTIGE Solo automatically derates the input at approximately 2% for every 1,000 feet of altitude. No alteration to the boiler or burner system is required.

Note 2: PRESTIGE Solo 399 output ratings are based off a thermal efficiency of 95.1%. Prestige Solo 250 output rating is based on DOE heating capacity.

Note 3: The IBR rating is based on piping and pick up allowance of 1.15. This allowance should be sufficient for the standard radiation requirements for a building load.

Note 4: Equivalent Direct Radiation (EDR) is based on 150 Btu/h per square foot EDR at 170°F average supply temperature and total net IBR rating.

Note 5: Minimum recommended system iron pipe size is based on temperature differential of 20°F.

Note 6: Minimum recommended natural gas header size is based on using schedule 40 metallic pipe 0.30" w.c. pressure drop and 100 feet of total equivalent length at a gas inlet pressure of less than 2 psi. Consult National Fuel Gas Code for alternate sizing.

CRR 500 and CRR 800 Pressure Drop Curve

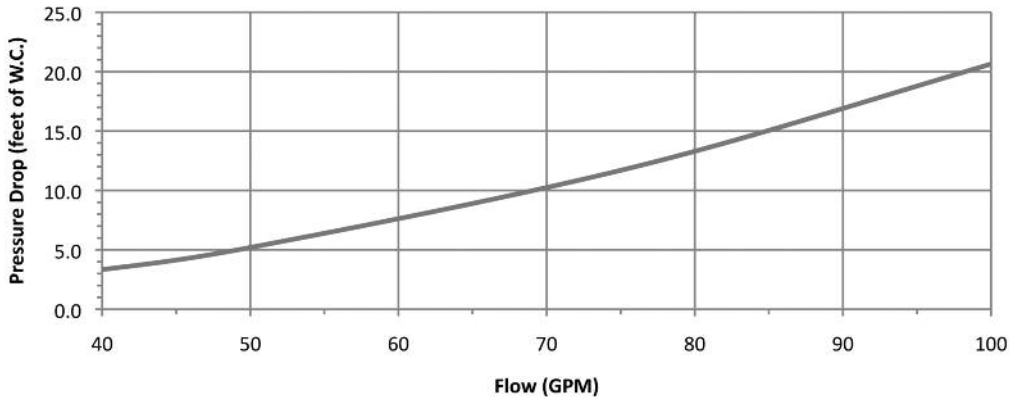

Graph 1: Pressure Loss Through CRR 500 and CRR 800

CRR 1200 Pressure Drop Curve

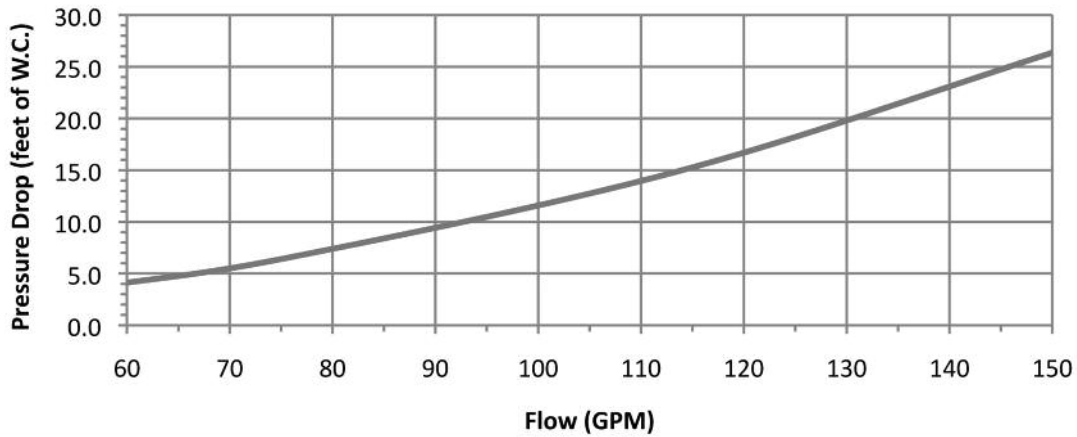

Graph 2: Pressure Loss Through CRR1200

CRR 1000 and CRR 1600 Pressure Drop Curve

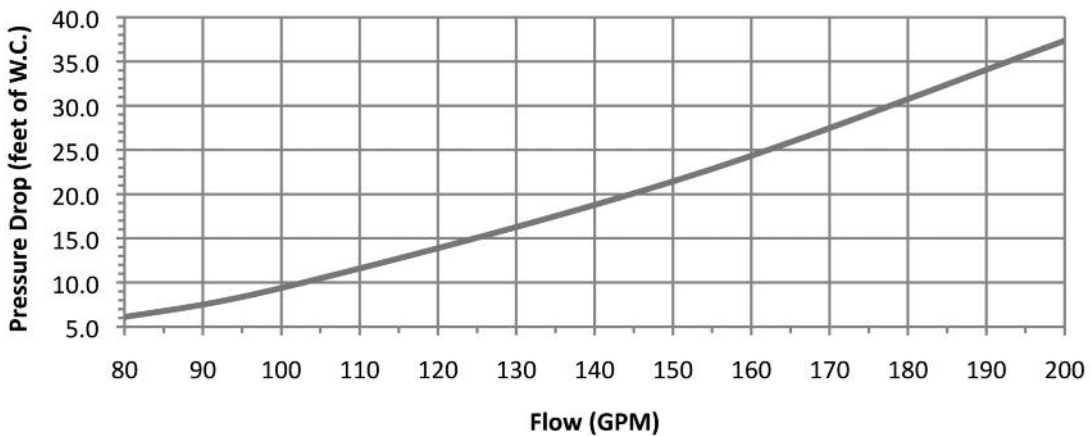

Graph 3: Pressure Loss Through CRR 1000 and CRR 1600

CRR2000 Pressure Drop Curve

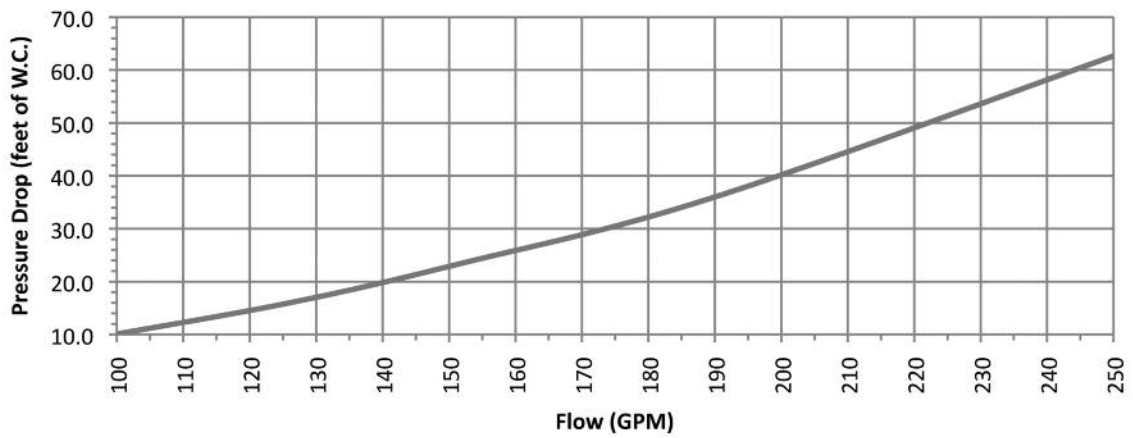

Graph 4: Pressure Loss Through CRR2000

Optional Strainer Pressure Drop Curve - PSCAS24

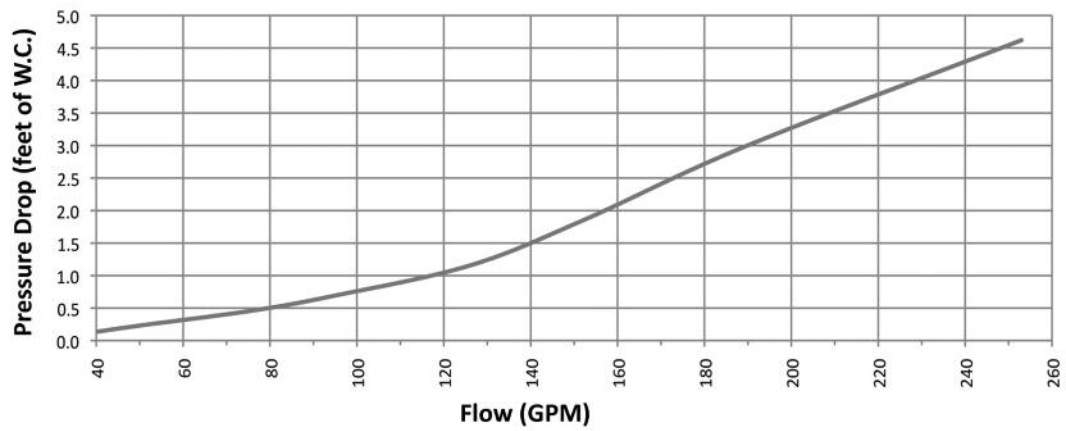

Graph 5: Pressure Loss Through Optional Strainer

Hydronic Junction System Pressure Drop Curve

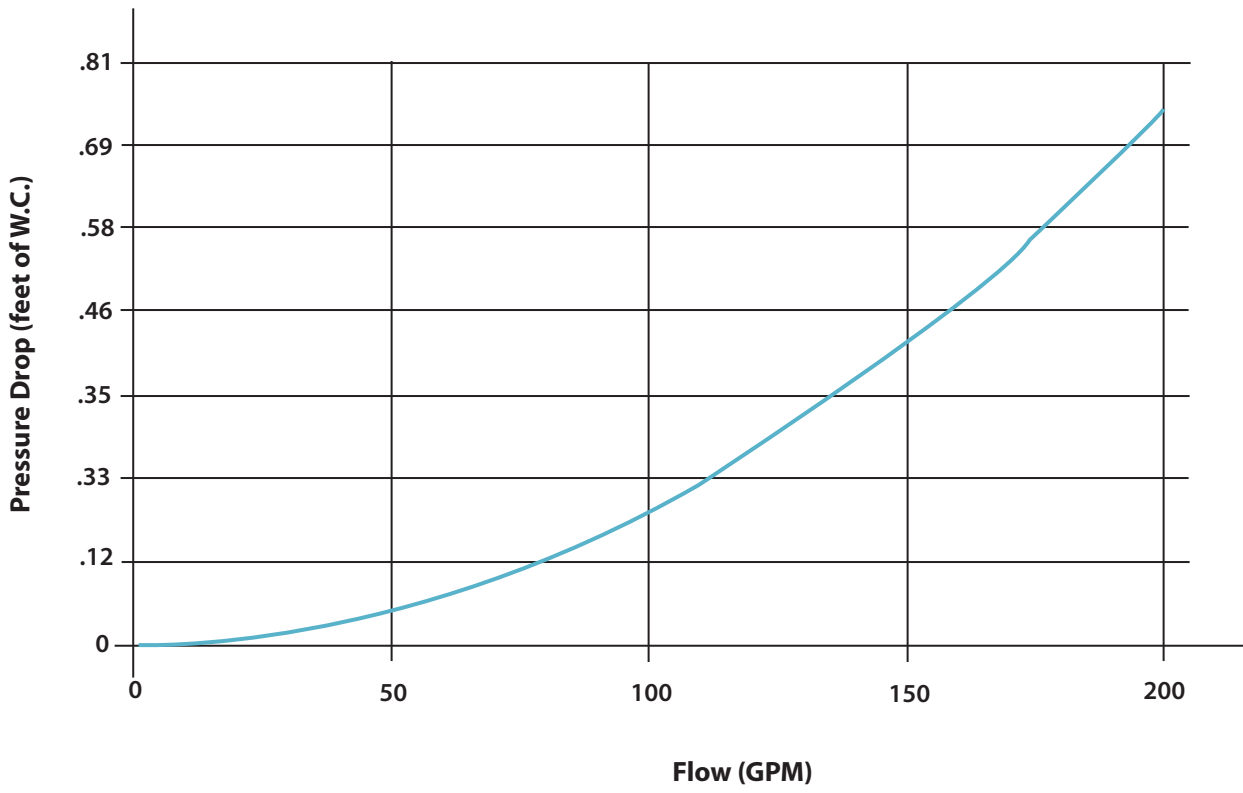

Graph 6: Pressure Loss Through Hydronic Junction System Piping

Additional quality water heating equipment available from Triangle Tube

PRESTIGE CONDENSING WALL MOUNTED BOILER



- 95% AFUE
- Fully modulating
- Natural gas or propane
- Stainless Steel Construction
- Direct vent with standard schedule 40 PVC
- Outdoor Reset

SMART SERIES INDIRECT FIRED WATER HEATERS



- Exclusive tank-in-tank design
- Stainless steel construction
- Available in 8 sizes and 2 models
- Limited LIFETIME residential warranty
- 15 year limited commercial warranty
- Self cleaning/self descaling design

TTP BRAZED PLATE HEAT EXCHANGERS

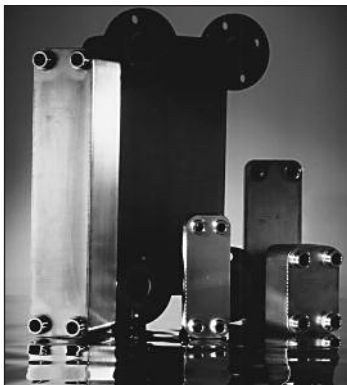

- For domestic water, snow melting, radiant floor, refrigeration
- Plates made of stainless steel, with a 99.9 % copper and brazed, ensuring a high resistance to corrosion
- Self cleaning and self descaling
- Computerized sizing available from Triangle Tube/Phase III
- Available in capacities from 25,000 BTU/hr to 5,000,000 BTU/hr



Freeway Center - 1 Triangle Lane - Blackwood, NJ 08012
Tel: (856) 228 8881 - Fax: (856) 228 3584
E-mail: sales@triangletube.com

