

Exalt Solo/Combi

Propane Gas (LP) to Natural Gas (NG) Conversion Instructions

These instructions shall be kept with the appliance literature for future reference.

 **WARNING**

Do not use the appliance with Natural Gas (NG) unless these Conversion Instructions have been fully implemented.

This conversion kit shall be installed by a qualified installer, service agency, or the gas supplier in accordance with the manufacturer's instructions and all applicable codes and requirements of the authority having jurisdiction.

If the information in these instructions is not followed exactly, a fire, an explosion, or production of carbon monoxide can result causing property damage, personal injury, or loss of life.

The qualified installer, service agency, or the gas supplier is responsible for the proper installation of this kit. The installation is not proper and complete until the operation of the converted appliance is checked as specified in this manufacturer's instructions supplied with the kit.

NOTICE

Whenever possible, conversion should be carried out before installing and connecting the boiler.

When you convert the appliance from Propane Gas (LP) to Natural Gas (NG), always make sure that all conversion work is complete before fully installing the air inlet piping.

DEFINITIONS

The following terms are used throughout this manual to bring attention to the presence of potential hazards or to important information concerning the product.

 **WARNING**

Indicates a potentially hazardous situation which, if ignored, can result in substantial property damage, serious injury, or death.

 **DANGER**

Indicates the presence of a hazardous situation which, if ignored, will result in substantial property damage, serious injury, or death.

NOTICE

Indicates special instructions on installation, operation or maintenance, which are important to the equipment but not related to personal injury hazards.

ideal
HEATING

ATTENTION
NATURAL GAS GAZ NATUREL

This appliance was converted on _____ (day/month/year)
Cet appareil a été converti le _____ (année/mois/jour)
to _____ gas (gas type)
pour fonctionner au gaz _____ (type de gaz)
with Kit No. _____ (reference number)
à l'aide de la trousse n° _____ (numéro de référence)

Combustion readings
Valeurs de combustion: _____% CO₂ _____% O₂ _____ ppm CO

by _____
par _____
Name and address of organization making this conversion - nom et adresse de l'organisme qui a effectué la conversion
that accepts the responsibility for the correctness of this conversion
qui accepte l'entière responsabilité de la qualité de la conversion

WARNING
THIS APPLIANCE WAS CONVERTED FROM PROPANE GAS TO NATURAL GAS
• Make sure the natural gas venturi and labels have been installed.
• Verify combustion readings are within the desired range specified in the Installation Manual.

AVERTISSEMENT
CET APPAREIL A ÉTÉ CONVERTI DU GAZ PROPANE AU GAZ NATUREL
• Assurez-vous que le venturi et les autocollants pour le fonctionnement au gaz naturel ont été installés.
• Vérifiez que les valeurs de combustion se situent dans la plage souhaitée, spécifiée dans les instructions de conversion ou le manuel d'installation des appareils.

EXALT	110	155	199
Conversion kit Trousse de conversion	EXRKIT07	EXRKIT09	EXRKIT11
Max/min inlet gas pressure Pression maxi/mini d'alim. gaz	13" WC MAX. 5" WC MIN.		
Manifold pressure Pression collecteur	0.04" WC		0.045" WC
Input rating Puissance	See existing rating plate Consulter la plaque signalétique existante		

241312 A01 Made in UK

Affix this conversion plate as close as possible to the existing rating plate
Coller cette plaque de conversion aussi près que possible de la plaque signalétique existante

NATURAL GAS GAZ NATUREL
ATTENTION ATTENTION
THIS GAS CONTROL VALVE HAS BEEN CONVERTED FOR USE WITH NATURAL GAS
CETTE COMMANDE/VANNE GAZ A ÉTÉ CONVERTIE POUR FONCTIONNER AU GAZ NATUREL

NG 

Installer Conversion Label (A)

To be filled in by the installer with relevant information and affixed close to the rating plate.

Gas Valve Conversion Label (B)

To be affixed on top of the gas control valve to indicate that conversion has been performed.

Controls Box Conversion Label (C)

To be affixed on top of the Controls Box to indicate that conversion has been performed.

Location of labels after conversion

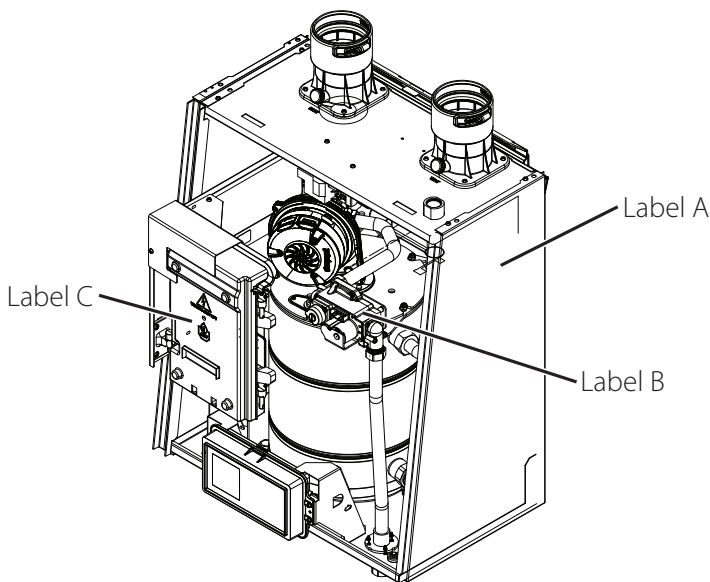

Figure 1 Exalt Wall Hung

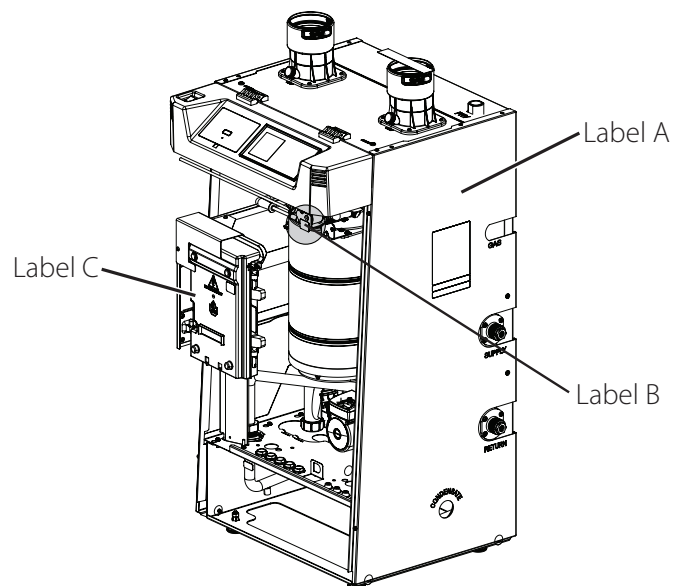



Figure 2 Exalt Floor Standing

The Natural Gas Rating Label (D) must be placed on top of the boiler performance data of the original rating label, leaving the top section of the original rating plate exposed.

SERIAL No:
IDEX155SAB0610



FOR YOUR SAFETY

Do not store or use gasoline or other flammable vapours and liquids in the vicinity of this or any other appliance.

223892 A05



EXALT SOLO 155

CATEGORY IV
FOR EITHER DIRECT VENT INSTALLATION OR FOR INSTALLATION USING INDOOR COMBUSTION AIR
FOR INSTALLTION ON WALL MOUNTING BRACKET
FOR ALCOVE OR CLOSET INSTALLATION

FUEL:	PROPANE
MAXIMUM GAS INLET PRESSURE:	13 In.WC [3.25kPa]
MINIMUM GAS INLET PRESSURE:	8 In.WC [1.99kPa]
MANIFOLD PRESSURE:	-0.05In.WC [-0.013kPa]
MAXIMUM OUTPUT:	140,000 Btu/h [41.0kW]
MAXIMUM INPUT:	155,000 Btu/h [45.4kW]
MINIMUM INPUT:	19,375 Btu/h [5.7kW]
ELEVATION (CANADA CSA 2.17):	0 - 4,500FT [0 - 1,370m]
MINIMUM RELIEF VALVE CAPACITY	140LBS PER HOUR
WORKING GAUGE PRESSURE HEATING	50 PSI [3.5 bar]

ELECTRICAL RATING 120V, 60Hz LESS THAN 12 AMPERES

TRIANGLE TUBE – MADE IN UK

<p>1240 FOREST PARKWAY, SUITE 100, WEST DEPTFORD, NEW JERSEY</p> <p>08066 04/18/2024 14:46:14</p>	<p>APPLIANCE CODES LP: X432</p>  <p>Intertek 5015379</p>	<p>COMPLIES WITH: ANSI Z21.13 - 2022 CSA 4.9 - 2022 ANSI Z21.10.3 - 2019 CSA 4.3 - 2019</p>
---	--	---

FUEL:	NATURAL GAS
MAXIMUM GAS INLET PRESSURE:	13 In.WC [3.25kPa]
MINIMUM GAS INLET PRESSURE:	5 In.WC [1.25kPa]
MANIFOLD PRESSURE:	-0.04In.WC [-0.010kPa]
MAXIMUM OUTPUT:	140,000 Btu/h [41.0kW]
MAXIMUM INPUT:	155,000 Btu/h [45.4kW]
MINIMUM INPUT:	19,375 Btu/h [5.7kW]
ELEVATION (CANADA CSA 2.17):	0 - 4,500FT [0 - 1,370m]
MINIMUM RELIEF VALVE CAPACITY	140LBS PER HOUR
WORKING GAUGE PRESSURE HEATING	50 PSI [3.5 bar]

ELECTRICAL RATING 120V, 60Hz LESS THAN 12 AMPERES

TRIANGLE TUBE – MADE IN UK

<p>1240 FOREST PARKWAY, SUITE 100, WEST DEPTFORD, NEW JERSEY</p> <p>08066 04/03/2024 15:38:27</p>	<p>APPLIANCE CODES NG: X431</p>  <p>Intertek 5015379</p>	<p>COMPLIES WITH: ANSI Z21.13 - 2022 CSA 4.9 - 2022 ANSI Z21.10.3 - 2019 CSA 4.3 - 2019</p>
---	--	---

Natural Gas Rating Label (D)

To be overlaid on top of the existing rating label.

GENERAL

Scope:

These instructions cover Propane Gas (LP) to Natural Gas (NG) conversion for Exalt Solo/Combi Wall Hung and Floor Standing boiler models. Each kit is supplied with one venturi suitable for use with that particular boiler model.

Kit Part Number:

EXRKIT07 (Exalt Solo 110)

EXRKIT09 (Exalt Solo/Combi 155)

EXRKIT11 (Exalt Solo/Combi 199)

Kit Contents:

- Installer Conversion Label **(A)**
- Gas Valve Conversion Label **(B)**
- Controls Box Conversion Label **(C)**
- Natural Gas Rating Label **(D)**
- Acoustic Foam (required for Solo 110 and Solo/Combi 155 models ONLY)
- Fibre Washers (2 off)
- Natural Gas Venturi (refer to Table 1 for venturi and injector diameters)

Table 1 - Natural Gas Conversion Venturis

Model	Venturi Diameter	Bottom Injector	Top Injector	Label Colour	Part No.
110 Solo	22mm	NG Ø3.40 mm	NG Ø3.50 mm	White	EXRKIT07
155 Solo	24mm	NG Ø3.90 mm	NG Ø3.95 mm	White	EXRKIT09
199 Solo	26mm	NG Ø5.00 mm	NG Ø4.20 mm	White	EXRKIT11
155 Combi	24mm	NG Ø3.90 mm	NG Ø3.95 mm	White	EXRKIT09
199 Combi	26mm	NG Ø5.00 mm	NG Ø4.20 mm	White	EXRKIT11

1.1 Applicability

Exalt Solo/Combi Wall Hung and Floor Standing Boiler models.

1.2 Safety Requirements



Failure to follow instructions provided in this document can result in substantial property damage, serious injury, or death.

- Instructions are for a qualified installer or service technician.
- Read all instructions before proceeding.

- Follow instructions in proper order.
- Make sure that the correct gas type is used.
- Contact the local Natural Gas (NG) supplier for recommended sizing of piping, tanks and 100 % lockup gas regulator.

1.3 Kit Installation

NOTICE

Upon completion of the conversion from to Propane Gas (LP) to Natural Gas (NG):

- Affix the new Natural Gas Rating Label **(D)** on top of the existing data plate.
- Affix the Gas Valve Conversion Label **(B)** onto the gas valve and the Controls Box Conversion Label **(C)** onto the controls box.
- Fill in and affix the Installer Conversion Label **(A)**.
- Refer to Figures 1 & 2 on page 2 for correct locations.

1.3.1 Required Tools and Material

- Adjustable Wrench / 10 mm Socket & Ratchet
- POZI Head Screwdriver
- Flat Head Screwdriver
- Calibrated Combustion Analyzer

1.3.2 Preliminary Instructions

1. Make sure that the venturi replacement kit is correct for the model and type of boiler. Refer to Kit Part Numbers.



FOR YOUR SAFETY:

- The gas supply shall be shut off prior to disconnecting the electrical power, before proceeding with the conversion,
 - The electrical power supply shall be turned off at external electric box prior to performing any operation on the internal parts of the boiler.
 - Failure to do so can result in substantial property damage, serious injury, or death.
2. Shut off the gas supply to the boiler at the main manual shut off valve.
 3. Disconnect electrical power at the external electric box.
 4. Remove the front panel of the boiler.

For the Floor Standing Boiler Model (FSB):

Remove the two securing screws on top of the control pod. Rotate the pod upwards. Lift the front panel to disengage the keyhole slots and remove the panel.

To Install the front panel - lower the front panel to engage the keyhole slots and re-fit the panel. Rotate the pod downwards and secure using the two screws.

For the Wall Hung Boiler Model:

Remove the securing screws holding the bottom of the front panel to the chassis. Pull the bottom of the front panel out and lift to disengage from the top mounting points.

To install the front panel - push the bottom of the front panel in to engage the top mounting points. Secure the bottom of the front panel to the chassis using the screw.

5. Use a voltmeter to make sure that there is no electrical power to the boiler. To do this apply the test equipment across the boiler's Live and Neutral voltage terminals, L and N.



ELECTRICAL SHOCK HAZARD
Always disconnect the electrical power before servicing the unit.

NOTICE

Do not remove the acoustic foam from the air inlet or the vent outlet. The air inlet does not need to be changed to convert from Propane to Natural Gas.

1.4 Removal of Propane Gas (LP) Venturi

1. Remove the air reference hose from the air inlet elbow. Then remove the air inlet elbow.
2. Rotate the venturi interface in a clockwise direction for approximately 60 degrees, to release the clamp mechanism. Then remove the venturi interface.
3. Loosen the nuts at each end of the gas valve to venturi pipe. Remove the gas valve to venturi pipe.



There are gaskets at both ends of the gas valve to venturi pipe. These gaskets must be reinstalled with the pipe. Refer to Figures 3, 4 & 5 for relevant boiler models. Do not cause damage to the gaskets.

4. Use a 10 mm socket and ratchet to remove the three (3) bolts that attach the venturi to the fan assembly. Remove the venturi from the fan assembly. When you remove the venturi from the fan assembly make sure that you do not cause damage to the O-ring gasket on the blower.

1.5 Install the Natural Gas (NG) Venturi



Always make sure that the O-ring gasket is correctly installed between the venturi and the blower. Failure to install the O-ring will cause a gas leak. Gas leaks can cause substantial property damage, serious injury, or death.

Always make sure that the two fibre washers are correctly installed between the gas valve, gas pipe and venturi. Failure to install the fibre washers will cause a gas leak. Gas leaks can cause substantial property damage, serious injury or death.

1. When you align the Natural Gas (NG) venturi, make sure that:

The UP arrow on the plastic housing points upward.

Before the gas pipe is installed, make sure that the threaded connection for the gas pipework is in the correct orientation.

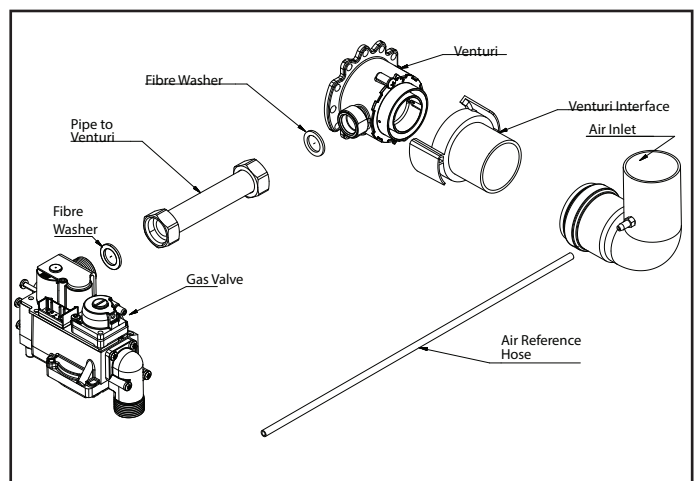

Figure 3 Exalt Solo 110 Gas Train

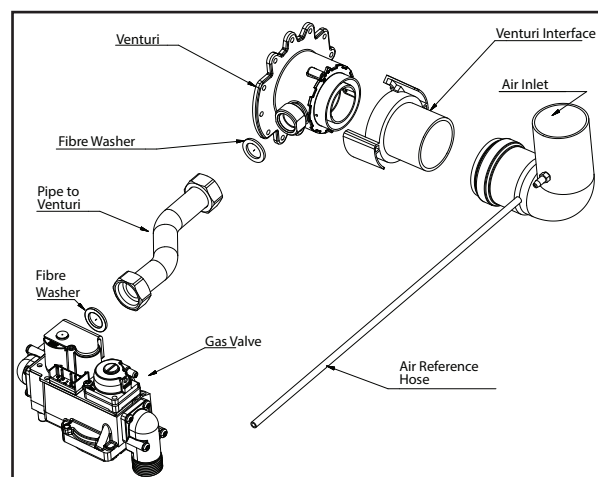

Figure 4 Exalt Solo/Combi 199 Gas Train

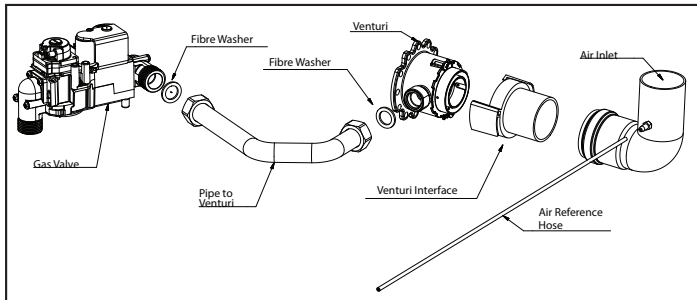

Figure 5 Exalt Solo/Combi 155 Gas Train

WARNING

Always make sure that the correct venturi for the model and variant is installed. Refer to Table 1 for the correct venturi and injector sizes.

- Propane (LP) venturi have a black manufacturer's label and an additional green Propane identification label.
- Natural Gas (NG) venturi have a white manufacturer's label and an additional yellow Natural Gas identification label (see below). The venturi used for this conversion must have these labels attached.



Failure to comply with this warning will affect the input rate and combustion of the boiler. This failure may cause substantial property damage, serious injury, or death.

NOTICE

Do not use adhesive on gaskets or O-rings during the assembly process.

2. Attach the venturi to the fan assembly with the three (3) bolts. Use a 10 mm socket and ratchet to tighten the bolts.
3. Assemble the venturi pipe to the gas valve and venturi. Always make sure that the gaskets are seated correctly before you tighten the nut.
4. Put the venturi interface on to the venturi. Rotate the venturi interface counterclockwise until it is in the locked position.
5. Install the air inlet elbow coupling. Then attach the air reference hose.
6. Place the Gas Conversion Label (B) on the gas valve and the Controls Box Conversion Label (C) onto the controls box (refer to Figures 1 & 2 on page 2 for the correct location).

WARNING

Failure to correctly install the air inlet elbow coupling and attach the air reference hose can affect combustion of the boiler. This type of failure may cause substantial property damage, serious injury, or death.

7. Open the manual gas shut off valve to the unit. Before the boiler is put into operation, each gas connection must be tested for leaks. Repair all leaks before the boiler is put into operation.

DANGER

- Prior to start-up and during initial operation, check for a gas leak using a combustible gas detector.
 - Do not check for gas leaks with an open flame. Use a bubble test.
 - Any leaks found shall be repaired immediately.
 - Do not proceed with the start-up if there is any indication of a gas leak.
 - Failure to comply with these instructions will result in substantial property damage, serious injury, or death.
8. Make sure the correct gas type is supplied to the boiler.
 9. Visually check the overall installation, checking around the unit for gas odour.

DANGER

If any gas leaks are found or suspected:

- Shut the unit down immediately.
- Use a gas detector or bubble test to locate the source of the gas leak and repair at once.
 - Do not check gas leaks with an open flame.
 - Do not operate the unit until the leak is corrected.
- Failure to comply with this procedure will result in substantial property damage, serious injury, or death.

1.6 Changing the Appliance Code

1. Refer to Figure 6. Press, and hold, the UP and DOWN buttons together.

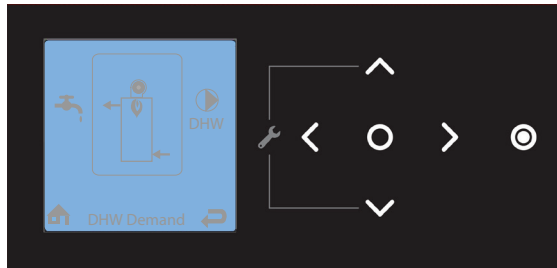

Figure 6 CTRLMax Navigation Control

2. Enter the access code 054:
 - Use the LEFT and RIGHT buttons to select a digit.
 - Use the UP and DOWN buttons to change the digit.
 - Press the center button to enter the access code.
3. With the CH/DHW SETTINGS icon highlighted, press the center button.
4. Press the down button to highlight the BOILER SETTINGS icon. Then press the center button.
5. Scroll down to highlight APPLIANCE SETTING. Then press the center button.
6. Enter the Natural Gas appliance code from the Natural Gas Rating Label (D).
 - Use the LEFT and RIGHT buttons to select a character.
 - Use the UP and DOWN buttons to change the character.
 - Press the center button to enter the appliance code.

1.7 Combustion Test and Adjustments



The installer MUST do a complete combustion check to make sure that the appliance meets the requirements of Table 2. These tests will make sure that combustion levels are correct at high and low input firing rates and that the burner will continue to operate efficiently.



Failure to comply with the requirements of this warning may cause injuries to personnel and substantial property damage.

- All combustion testing and adjustments must be done by a qualified installer, service agency or gas supplier.
- All combustion equipment measurements must be done with calibrated equipment.
- Always refer to Table 2 to check that the combustion measurements are within the acceptable range.



Failure to do a complete combustion test at both high and low input rates may result in incomplete combustion and the production of carbon monoxide. This can cause severe personal injury, death or substantial property damage.

1. Press the UP and DOWN buttons at the same time, for three seconds to get access to the installer functions menu. Refer to Figure 6.
2. Enter the access code 054:
 - Use the LEFT and RIGHT buttons to select a digit.
 - Use the UP and DOWN buttons to change the digit.
 - Press the center button to enter the access code.
3. Press the right-hand button to highlight the MANUAL OPERATION screen. Then press the center button.

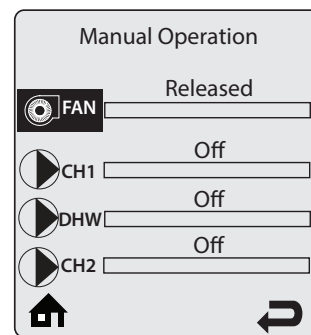

Figure 7 CTRLMax Manual Operation

4. Make sure that the FAN icon is highlighted. Press the center button to manually fire the burner and apply power to the CH circulator. Refer to Figure 7.
5. Adjust the Natural Gas (NG) supply regulator provided by the gas supplier for 13-inch W.C. maximum pressure at flow or no flow conditions to the burner. There must be a minimum 5-inch W.C. during flow conditions to the burner.

WARNING

Do not adjust or attempt to measure gas valve outlet pressure. The gas valve is factory-set for the correct outlet pressure. This setting is suitable for Natural Gas (NG) and Propane Gas (LP) and requires no field adjustment. Attempts by the installer to adjust or measure the gas valve outlet pressure can result in damage to the valve, causing substantial property damage, serious injury, or death.

WARNING

The Natural Gas (NG) venturi assembly must never be modified or replaced with a different assembly. Refer to Table 1 for the full specification. Failure to use the required Natural Gas (NG) venturi assembly can result in substantial property damage, serious injury or death.

NOTICE

There must be a sufficient CH load to dissipate heat generated during the combustion test. If a sufficient CH load is not available, an indirect water heater can be used to dissipate the heat. This will create a DHW demand which will start the DHW circulator.

6. Operating sequence:

Perform the following ignition operating sequence check prior to firing the boiler with a gas supply :

- a. Shut off the gas supply to the boiler.
- b. Adjust the thermostat demand to the highest setting
- c. Make sure the fan operates a prepurge function prior to activating the igniter.
- d. Once the igniter has deactivated, make sure the fan operates a postpurge function prior to reactivating the igniter.
- e. Adjust the thermostat to its lowest setting and proceed with the high fire check.

WARNING

Checking and adjusting high fire must be done before setting low fire. Failure to set high fire first may cause toxic gas combustion and can result in substantial damage, serious injury or death.

7. Press the right-hand button to adjust the firing rate to 100 % (high fire). Hold down the right-hand button to increase the firing rate.

8. If the combustion levels during high fire are outside the recommended combustion settings (refer to Table 2), use a flat-blade screwdriver to adjust the throttle screw (refer to Figure 8). Use the adjustments shown below to increase or decrease oxygen (O₂) and carbon dioxide (CO₂) levels within the unit.

Counter-clockwise adjustment of the throttle screw at High Fire (100% firing rate) will decrease O₂ levels and increase CO₂ levels.

Clockwise adjustment of the throttle screw at High Fire (100% firing rate) will increase O₂ levels and decrease CO₂ levels.

9. After the combustion level is set at high fire, manually put the boiler into LOW FIRE mode. To do this, press the left-hand button to adjust firing rate down to 1 % (low fire).

If the combustion levels (O₂ or CO₂) during low fire are outside the recommended combustion settings in Table 2, contact Triangle Tube Technical Support.

10. Press the center button while the FAN icon is highlighted to shut down the burner.
11. Press the LEFT or RIGHT buttons to highlight the HOME SCREEN icon to exit the service mode.
12. Replace the front panel and put the boiler back into operation.

Figure 8 Throttle Screw Location

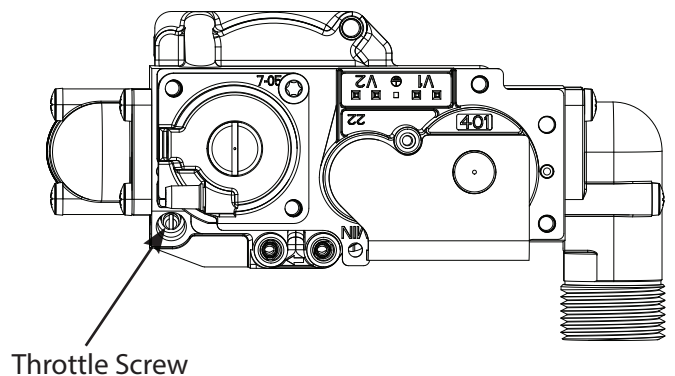

Table 2 - Combustion Settings

		Natural Gas 110, 155	Natural Gas 199
High Fire	CO ₂ Range	9.0 % to 10.5 %	8.5 to 10.5 %
	CO ₂ Target	9.5 %	
	O ₂ Range	4.85 % to 2.15%	5.75 % to 2.15 %
	O ₂ Target	3.95 %	
	CO Max	< 150ppm @ 9.5 % CO ₂	
Low Fire	CO ₂ Range	9.0 % to 10.0 %	8.5 % to 10.0 %
	CO ₂ Target	9.5 %	9.0 %
		Target values are equivalent to High Fire values. Make sure that all measured CO ₂ values are less than or equal to High Fire CO ₂ measurements.	
	O ₂ Range	4.85 % to 3.0 %	5.75 % to 3.0 %
	O ₂ Target	3.95 %	4.85 %
		Target values are equivalent to High Fire values. Make sure that all measured O ₂ values are higher than or equal to High Fire O ₂ measurements.	
	CO Max	10 ppm	



If combustion levels at high (100%) or low (1%) fire are not within the range of Table 2, shut the boiler down and contact Ideal USA Technical Support. Failure to comply with this requirement can result in substantial damage, serious injury or death.

1.8 Measure Input Rate - Natural Gas (NG)

NOTICE

This section can only be performed when a gas meter is present.

1. Press the **OK** button while the **FAN** icon is highlighted and Press the **RIGHT** button to adjust the firing rate to **100 %** (high fire).
2. Operate the unit for approximately 10 minutes.
3. Turn off all gas appliances within the building, except the EXALT appliance.
4. At the gas meter, record the time required to use one cubic foot of gas.

5. Calculate Natural Gas (NG) input using the following equation:
 $3600 \times 1000 / \text{number of seconds recorded for one cubic foot of gas} = \text{BTU/H.}$
6. The BTU/H calculated should approximate the input rating listed on the unit rating label and in the table below.
7. Press the **OK** button while the fan icon is highlighted to shutdown the burner.
8. Press the **LEFT** or **RIGHT** button to highlight the home screen icon and exit the service mode.

Boiler Model	Fuel	Input (Btu/h)
Exalt 110 Solo	Natural / Propane	13,750 - 110,000
Exalt 155 Solo	Natural / Propane	19,375 - 155,000
Exalt 199 Solo	Natural / Propane	24,875 - 199,000
Exalt 155 Combi	Natural / Propane	19,375 - 155,000
Exalt 199 Combi	Natural / Propane	24,875 - 199,000

NOTICE

Input and output ratings are shown for sea level applications. The EXALT features altitude compensation, altitude of the boiler must be inputted via the EXALT menu. Failure in selecting the correct altitude may compromise boiler ignition performance and will derate the boiler by 1.7 % per 1000 ft above sea level.

1.9 Follow -on Tasks

- Fill in the Installers conversion data label **(A)** with the required conversion information and with combustion values.
- Affix the completed Installers Conversion Label **(A)** and Natural Gas Rating Label **(D)** (refer to Figures 1 & 2 on page 2 for the correct location).