

Exalt Combustion Chamber Insulation Replacement

Kit Part Number	Description	Model
EXRKIT18	Insulation/Gasket Replacement	Exalt 110
EXRKIT19	Insulation/Gasket Replacement	Exalt 155 Models
EXRKIT20	Insulation/Gasket Replacement	Exalt 199 Models

Each Kit Includes:

- Combustion Chamber Insulation / Gasket

Recommended Tools:

- Adjustable Wrenches
- Phillips Head Screwdriver
- Torx Screwdrivers, T-10, T-20, T-25
- 10 mm Socket and/or 10 mm Open Ended Wrench

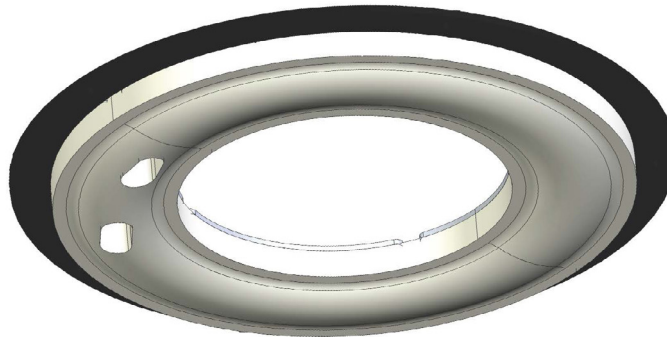

Fig. 1: Combustion Chamber insulation/gasket

WARNING

Indicates a potentially hazardous situation which, if ignored, can result in serious injury or substantial property damage.

NOTICE

Indicates special instructions on installation, operation or maintenance, which are important to equipment but not related to personal injury hazards.

WARNING

For your safety, turn off electrical power supply at service panel and allow unit to cool before proceeding to avoid possible electrical shock and scald hazard. Failure to do so can cause severe personal injury or death.

WARNING

Failure to follow instructions below can result in severe personal injury or damage if ignored.

- Instructions are for a qualified installer/ service technician only.
- Read all instructions before proceeding.
- Follow instructions in proper order.

Exalt

Combustion Chamber Insulation Replacement

1. Preliminary Instructions

1. Verify that the insulation replacement kit is correct for the model of boiler. See table on page 1.
2. Carefully open and unpack the PARTS BOX from its shipping carton.
3. Carefully remove and check for any damage.

NOTICE

Installing damaged insulation/gasket will cause malfunction of the boiler. Contact IdealUSA right away if the in-sulation/gasket is damaged in any way.

4. Turn off the electrical power supply to the boiler.
5. Close the manual gas shut off valve to the unit.

2. Removal of the old Combustion Chamber Insulation/Gasket

1. Turn power to the unit "OFF" and allow unit to cool.
2. Shut off gas supply to the inlet of the unit at the main manual shutoff valve to the unit.
3. Remove front jacket panel on the top of the boiler
4. Disconnect all the wires from the gas valve, blower and igniter.

NOTICE

Mark the proper location of all wires before removing them.

5. Remove the air inlet elbow from the venturi. Leave the elbow attached to the air inlet connection at the top of the boiler.
6. Disconnect the gas supply piping to the venturi. Unscrew the nut on either the venturi or the gas valve. Do not discard the gasket as they will be re-used.
7. Unbolt the four bolts securing blower from the burner mounting plate. Do NOT discard the blower gaskets. Do not discard the bolts as they will be re-used. Remove the blower/venturi/gas pipe assembly from the boiler.

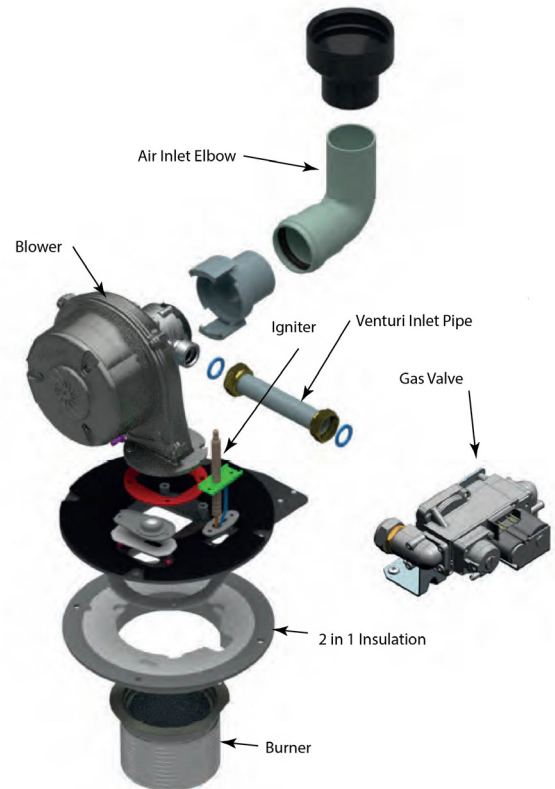

Fig. 1: Exalt 110 Burner Assembly

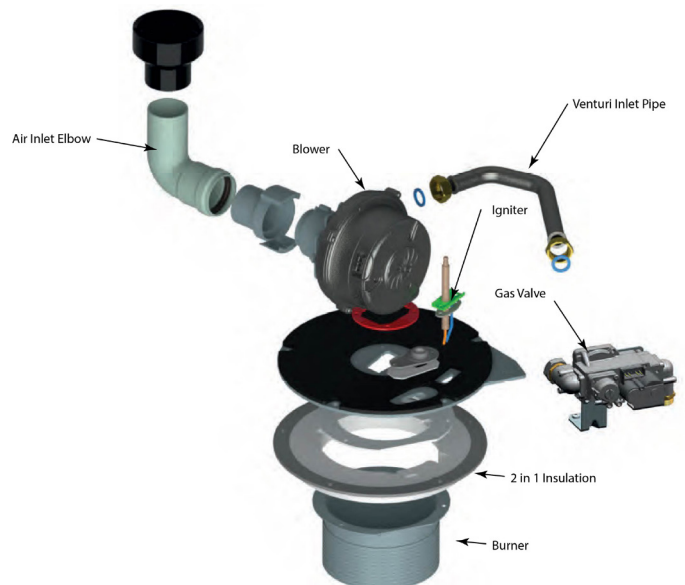

Fig. 2: Exalt 155 Burner Assembly

Exalt Combustion Chamber Insulation Replacement

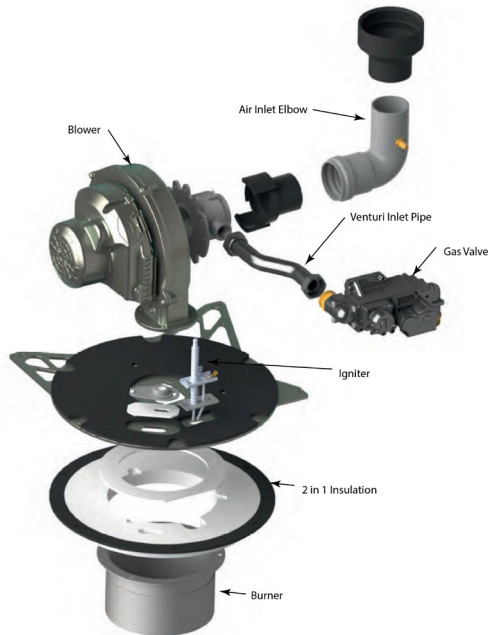

Fig. 3: Exalt 199 Burner Assembly

2. Carefully re-insert the burner assembly into the heat exchanger body. Align the burner assembly and igniter with the combustion chamber insulation to avoid insulation damage.

NOTICE

Ensure to not damage the igniter or burner head during re-installation.

3. Hand tighten the Burner Plate Mounting Nuts to hold the burner assembly in place. Then using a wrench tighten each nut to 44-53 in-lbs.

WARNING

Do not over tighten. Pinching or tearing of the burner plate gasket may occur causing the possible escape of combustion gases from the combustion chamber resulting in death, serious injury or substantial property damage.

4. Reinstall the blower gaskets onto the burning mounting plate and reattach the blower/venturi/gas line to the burner mounting plate. Tighten the blower bolts to 62-71 in-lbs of torque.

WARNING

Ensure the gasket is in place before reassembly. Failure to do so can result in death, serious injury or substantial property damage.

5. Reconnect the gas supply piping to the venturi. Ensure the pipe gasket is properly seated before tightening the nut.

WARNING

Ensure the gasket is in place before reassembly. Failure to do so can result in death, serious injury or substantial property damage.

6. Reattach the air inlet elbow to the venturi.
7. Reattach all the wires to the gas valve, blower and igniter.

8. Remove the nuts securing the burning mounting plate to the rear jacket panel. These screws are for shipping protection and can be discarded.
9. Remove the burner plate mounting nuts. Do not discard the nuts as they will be reused. Remove the burner mounting plate straight up from the heat exchanger body to ensure the igniter and burner head is not damaged. See Fig. 4

3. Installation of the new Combustion Chamber Insulation/Gasket

1. Install the combustion chamber insulation on the heat exchanger with the fabric side down and the igniter and sight glass cut outs line up with the cut-outs in the mounting plate.

NOTICE

For the reassembly process do not use adhesives on ANY gasket surface.

WARNING

Ensure the gasket is in place before reassembly. Failure to do so can result in death, serious injury or substantial property damage.

Exalt

Combustion Chamber Insulation Replacement

8. Turn on gas supply to the inlet of the unit at the main manual shutoff valve to the unit. Check and test all gas connections for leaks. Repair leaks if found.



Do not check for gas leaks with an open flame. Use a bubble test. Failure to check for gas leaks can cause severe personal injury, death or substantial property damage.

9. Turn power to the unit "ON". The unit is now ready to be placed back into service.