



prestige

Control Application Supplement - TriMax



! WARNING

This document is intended to be used by a factory trained and qualified heating contractor or service technician only. Read all instructions within this document and within the PRESTIGE Boiler Installation and Maintenance Manual before proceeding. It is recommended to follow the procedures in the steps given. Skipping or missing procedural steps could result in severe personal injury, death or substantial property damage.

Table of Contents

NOTICE

This Control Application Supplement applies to TriMax controls with the following software version numbers:

**Display SWv.1.14
Burner Controller SW v.0.14**

This software version numbers are displayed on the initial screen after turning on the unit.

Product and Safety Information	1
Operating Information	2
Entering Installer Access Code.....	3
Trimax Installer Menu Structure	4
CH Settings.....	5-13
DHW Settings.....	14-18
Boiler Settings.....	19-20
Reset All Settings	20
Factory Trimax Settings	21
Cascade Operating Information	22
Trimax Cascade Menu Structure	23
Cascade Installation	24-33
Cascade Information.....	34
Cascade Settings.....	35-40
Modbus Interface	41-42
Manual Operation.....	43

Product and Safety Information

IMPORTANT INFORMATION - READ BEFORE PROCEEDING

 **WARNING**

This document is intended to be used by a factory trained and qualified heating contractor or service technician only. Read all instructions within this document and within the **PRES-TIGE Boiler Installation and Maintenance Manual** before proceeding. It is recommended to follow the procedures in the steps given. Skipping or missing procedural steps could result in severe personal injury, death or substantial property damage.

DEFINITIONS

The following terms are used throughout this manual to bring attention to the presence of potential hazards or to important information concerning the product.

 **DANGER**

Indicates the presence of a hazardous situation which, if ignored, will result in death, serious injury or substantial property damage.

 **WARNING**

Indicates a potentially hazardous situation which, if ignored, can result in death, serious injury or substantial property damage.

 **CAUTION**

Indicates a potentially hazardous situation which, if ignored, may result in minor injury or substantial property damage.

NOTICE

Indicates special instructions on installation, operation or maintenance, which are important to the equipment but not related to personal injury hazards.

BEST PRACTICE

Indicates recommendations made by ACV-Triangle Tube for the installers which will help to ensure optimum operation and longevity of the equipment.

NOTICE

ACV-Triangle Tube reserves the right to modify the technical specifications and components of its product without prior notice.

Operating Information

OPERATING INFORMATION

The TriMax Boiler Management System is designed to be flexible yet easy to use. TriMax monitors and controls the Prestige to operate as efficiently as possible. TriMax monitors the boiler supply, return and flue gas temperatures and operates the igniter, gas valve and blower. TriMax uses this information to modulate the boiler's firing rate to maintain the required setpoint.

TriMax offers many advanced control options, which may be adjusted for various applications to achieve optimum boiler efficiency and operation.

- Two central / space heating (CH) call inputs with separate outdoor reset curves.
- Domestic Hot Water (DHW) call input with optional priority.
- System temperature sensing and control with an optional system temperature sensor.
- Cascade function allows up to six Prestige boilers to operate together in a single heating system.
- Modbus interface for integrating with building management systems.

These advanced features are adjustable in the Installer Menu after entering an access code.

Entering Installer Access Code

ENTERING INSTALLER ACCESS CODE

The **INSTALLER** button (the small round button) provides the installing contractor with full access to all available features after entering an access code.

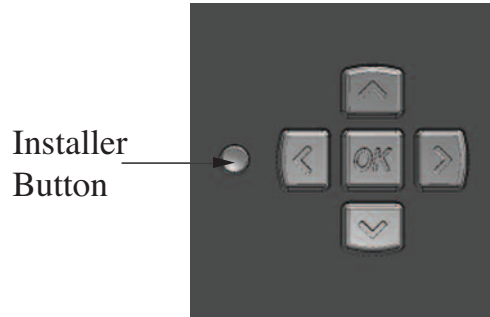

Fig. 1: TriMax Navigation Buttons





Entering installer access code procedure

1. Press the round **INSTALLER** button.
2. Enter the installer access code “054” by using the **LEFT** and **RIGHT** buttons to select a digit and the **UP** and **DOWN** buttons to change the digit. Press the **OK** button to enter the access code.
3. The Installer Menu will be displayed after successfully entering the access code. The Home Screen will be displayed if the access code is not entered correctly.

NOTICE

Entering the installer access code allows the installer to make adjustments for 30 minutes. After 30 minutes, the access code will need to be entered again to make any adjustments.

The Installer Menu is divided into four sections:

1. CH & DHW Settings  – Allows the installer to adjust the boilers central / space heating, domestic hot water and boiler settings for the application. See pages 5 through 20.
2. Manual Operation  – The burner and circulators can be manually enabled for testing. See page 43.
3. Reset All Settings  – Resets all CH, DHW, Boiler, and Cascade Settings back to the factory defaults. See pages 20 through 21.
4. Cascade  – Allows the installer to setup, adjust, and monitor the Cascade System. See pages 22 through 40.

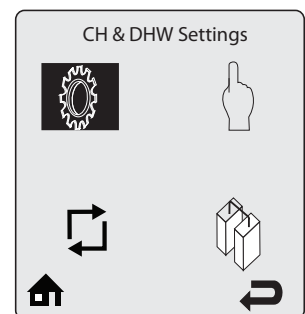

Trimax Installer Menu Structure

TriMax Installer Menu Structure

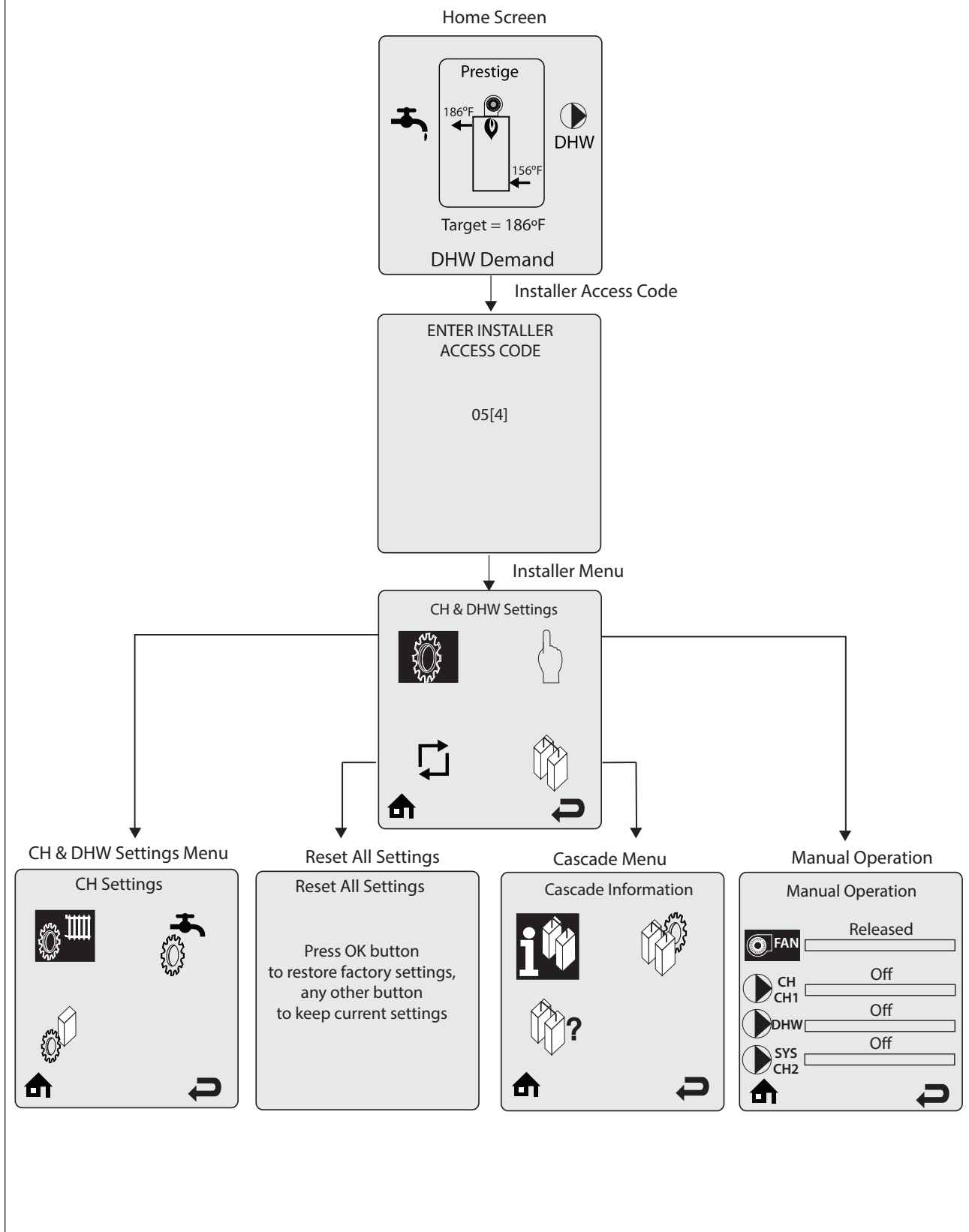

CH Settings

CH Settings

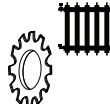

Navigation: Home Screen>Installer Menu>CH & DHW Settings>CH Settings

The CH Settings menu contains settings related to central heating operation. Each line contains a CH Setting followed by its current value. Six CH Settings are displayed on the screen at one time. Press the **UP** or **DOWN** buttons to scroll through additional CH Settings.

Heating Operation

Default: Enabled

Heating Operation allows the central heating function to be enabled and disabled. Press the **UP** or **DOWN** buttons to select Enabled or Disabled then press the **OK** button to store the setting.

- **Enabled** - The Prestige will respond to a central heating call.
- **Disabled** - The Prestige will not respond to a central heating call. The heating operation disabled icon  is displayed on the home screen when central heating operation has been disabled.

Demand Type

Default: Switch & Outdoor Reset

Demand Type allows the installer to select how a CH Demand is generated. Press the **UP** or **DOWN** buttons to select the CH Demand Type then press the **OK** button to store the setting. The CH Demand options are:

- **Switch & Outdoor Reset** – A central heating call from a dry contact switch will enable the Prestige and the setpoint will vary with the outdoor temperature for central heating calls
- **Switch & Setpoint** - A central heating call from a dry contact switch will enable the Prestige and the setpoint will be fixed for central heating calls
- **Constant & Outdoor Reset** - The Prestige will maintain setpoint and the central heating circulators will be constantly enabled without an external call from a dry contact switch. The central heating circulators will be disabled when the outdoor temperature exceeds the Warm Weather Shutdown Temperature setting. The setpoint will vary with the outdoor temperature for central heating calls.
- **Constant & Setpoint** - The Prestige will maintain setpoint and the central heating circulators will be constantly enabled without an external call from a dry contact switch. The central heating circulators will be disabled when the outdoor temperature exceeds the Warm Weather Shutdown Temperature setting. The setpoint will be fixed for central heating calls.
- **0-10V Modulation Signal** – This option allows the Prestige firing rate to be controlled by an external control system with a 0-10 VDC signal.

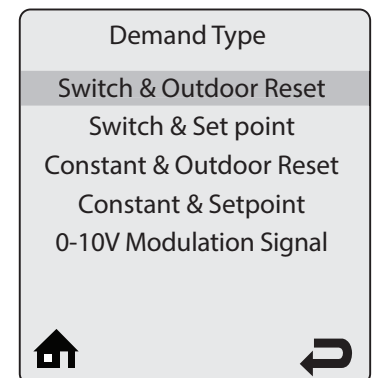
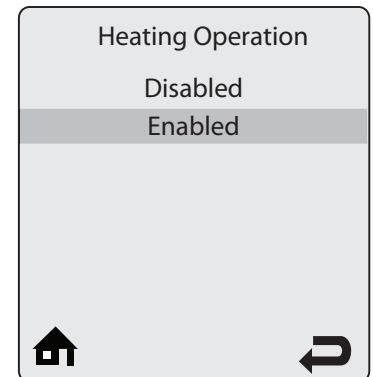
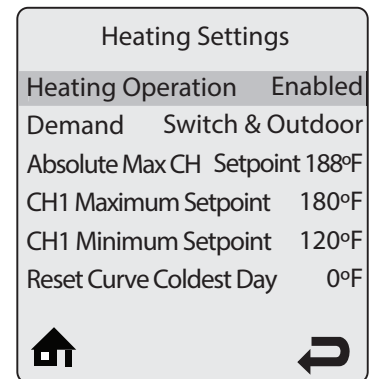

CH Settings

Absolute Max CH Setpoint

Default: 188°F [87°C]

Absolute Max CH Setpoint can be used to prevent a user from adjusting the central heating setpoint or outdoor reset curve above a safe operating temperature in the EZ Setup Menu. A warning screen will be displayed in EZ Setup if the user attempts to raise the setpoint above the Absolute Max CH Setpoint. The Absolute Max CH Setpoint will be displayed on the outdoor reset curve in EZ Setup if the user selects an outdoor reset curve which goes above the Absolute Max CH Setpoint. Press the **LEFT** or **RIGHT** buttons to adjust the Absolute Max CH Setpoint then press the **OK** button to store the setting.

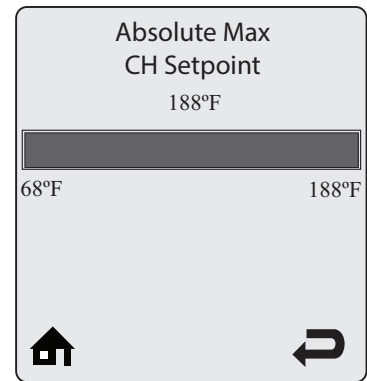

CH1 Maximum Setpoint

Default: 180°F [82°C]

CH1 Maximum Setpoint is the maximum setpoint for a CH1 heating call when an Outdoor Reset option is chosen in CH Demand. CH1 Maximum Setpoint is the fixed setpoint for a CH1 heating call when a Setpoint option is chosen in CH Demand. Press the **LEFT** or **RIGHT** buttons to adjust the CH1 Maximum Setpoint then press the **OK** button to store the setting.

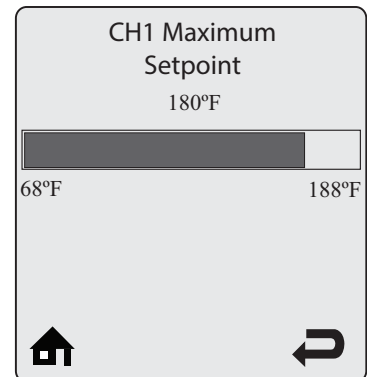

CH1 Minimum Setpoint

Default: 120°F [49°C]

CH1 Minimum Setpoint is the minimum setpoint for a CH1 heating call when an Outdoor Reset option is chosen in CH Demand. This setting is not applicable when a Setpoint option is chosen in CH Demand. CH1 Minimum Setpoint must be set equal to or below the CH1 Maximum Setpoint. Press the **LEFT** or **RIGHT** buttons to adjust the CH1 Minimum Setpoint then press the **OK** button to store the setting.

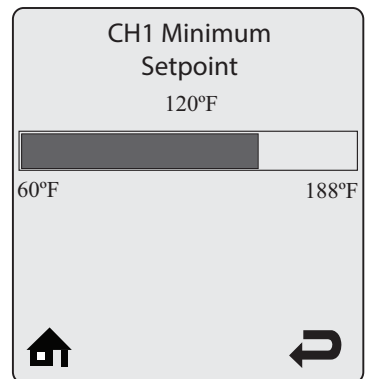

Reset Curve Coldest Day

Default: 0°F [-18°C]

Reset Curve Coldest Day is the coldest outdoor design temperature of the heating system when an Outdoor Reset option is chosen in CH Demand. This setting is not applicable when a Setpoint option is chosen in CH Demand. Press the **LEFT** or **RIGHT** buttons to adjust the Reset Curve Coldest Day then press the **OK** button to store the setting.

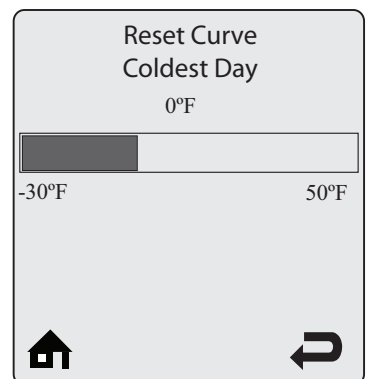

CH Settings

Reset Curve Warmest Day

Default: 64°F [18°C]

Reset Curve Warmest Day is the warmest outdoor design temperature of the heating system when an Outdoor Reset option is chosen in CH Demand. This setting is not applicable when a Setpoint option is chosen in CH Demand. Press the **LEFT** or **RIGHT** buttons to adjust the Reset Curve Warmest Day then press the **OK** button to store the setting.

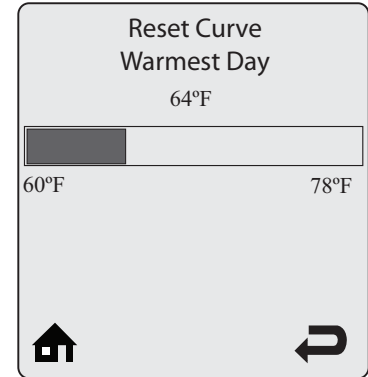

CH2 Circuit

Default: Enabled

CH2 Circuit allows the CH2 Maximum and Minimum Setpoints to be enabled and disabled. When disabled, the CH2 heating call will operate using the CH1 Maximum and Minimum Setpoints. Press the **UP** or **DOWN** buttons to select Enabled or Disabled then press the **OK** button to store the setting.

- **Enabled** – A CH2 heating call will use CH2 Maximum and Minimum Setpoints.
- **Disabled** – A CH2 heating call will use CH1 Maximum and Minimum Setpoints.

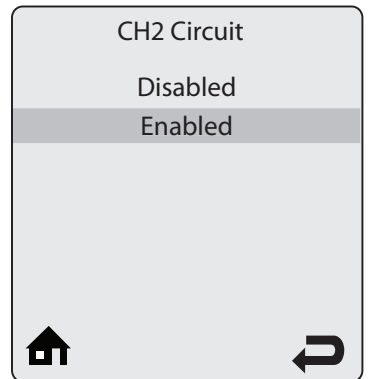

CH2 Maximum Setpoint

Default: 140°F [60°C]

CH2 Maximum Setpoint is the maximum setpoint for a CH2 heating call when an Outdoor Reset option is chosen in CH Demand. CH2 Maximum Setpoint is the fixed setpoint for a CH2 heating call when a Setpoint option is chosen in CH Demand. Press the **LEFT** or **RIGHT** buttons to adjust the CH2 Maximum Setpoint then press the **OK** button to store the setting.

CH2 Minimum Setpoint

Default: 80°F [27°C]

CH2 Minimum Setpoint is the minimum setpoint for a CH2 heating call when an Outdoor Reset option is chosen in CH Demand. This setting is not applicable when a Setpoint option is chosen in CH Demand. CH2 Minimum Setpoint must be set equal to or below the CH2 Maximum Setpoint. Press the **LEFT** or **RIGHT** buttons to adjust the CH2 Minimum Setpoint then press the **OK** button to store the setting.

Warm Weather Shutdown

Default: OFF

Warm Weather Shutdown allows the installer to enter an optional outdoor temperature at which to disable the central heating function and any circulators placed into constant circulation with the Pump Constant Circulation setting. The Prestige will continue to respond to a domestic hot water call or a 0-10V Modulation Signal when the outdoor temperature exceeds the Warm Weather Shutdown Temperature setting. Press the **LEFT** or **RIGHT** buttons to adjust the Warm Weather Shutdown Temperature then press the **OK** button to store the setting. The Warm Weather Shutdown icon  is displayed on the home screen when the outdoor temperature reaches the Warm Weather Shutdown Temperature.

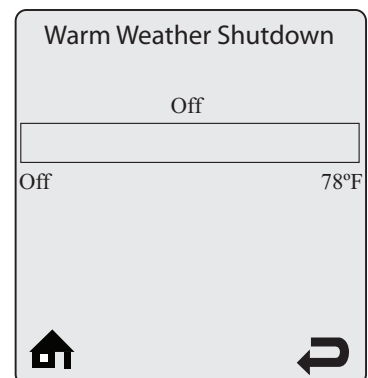

CH Settings

Pump Constant Circulation

Default: Disabled

Pump Constant Circulation allows the central heating circulators to be constantly enabled even without a central heating call. Pump Constant Circulation can be disabled by the Warm Weather Shutdown function. A domestic hot water call will cause the circulators to be disabled during the domestic call as long as DHW Priority is enabled. Press the **UP** or **DOWN** buttons to select Enabled or Disabled then press the **OK** button to store the setting.

- **Enabled** – The central heating circulators will be enabled for constant circulation without a central heating call.

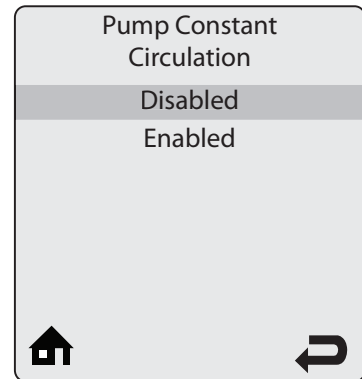

Table 1: Circulator Operation with Constant Circulation = Enabled

Prestige Model	CH2 Pump/ System Pump	Auxillary Boiler Pump	DHW Pump	CH (1) Pump
Solo	ON	ON	OFF	ON
Excellence	ON	ON	OFF	OFF

- **Disabled** – The central heating circulators will only be enabled during a central heating call.

CH Post Pump Time

Default: 1 Minute

CH Post Pump Time sets how long the central heating circulators will continue to operate at the completion of a heating call. Reference System Pump in CH Settings on page 10 to determine which circulators will continue to operate. Any call during the CH Post Pump Time will be ignored until the post pump has completed. The CH Post Pump feature allows the heat remaining in the boiler at the completion of a call to be sent to the heating system, which will improve the overall efficiency of the system. Press the **LEFT** or **RIGHT** buttons to adjust the CH Post Pump Time then press the **OK** button to store the setting.

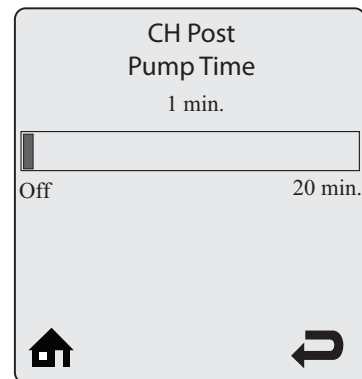

Freeze Protection

Default: Enabled

Freeze Protection allows the freeze protection feature to be enabled and disabled. Press the **UP** or **DOWN** buttons to select Enabled or Disabled then press the **OK** button to store the setting.

- **Enabled** – The Freeze Protection feature is enabled to protect the boiler from freezing. This feature monitors the boiler water temperature and responds as follows when no call is present:
 - 46°F [8°C] – Auxiliary Boiler Pump ON
 - 42°F [6°C] – CH(1), Auxiliary Boiler & System Pumps ON. Burner operates at low fire.
 - 60°F [15°C] – Freeze protection ends. Burner & all pumps OFF after completing CH Post Pump Time.
- **Disabled** – The Freeze Protection feature is disabled.



CH Settings

WARNING

Freeze Protection should only be disabled when the system contains antifreeze to prevent the system from freezing. Serious damage could occur to the Prestige as well as the entire heating system if Freeze Protection is disabled without antifreeze in the system.

WARNING

The Prestige should NEVER be installed in a location where freezing could occur. Subjecting the Prestige to freezing conditions could lead to freezing of the condensate possibly causing serious injury or death.

Frost Protection Setpoint

Default: -22°F [-30°C]

Frost Protection will enable the central heating circulators if the outdoor temperature falls below the Frost Protection Setpoint and no call is present. This feature requires using the outdoor temperature sensor and is always active and cannot be disabled. Press the **LEFT** or **RIGHT** buttons to adjust the Frost Protection Setpoint then press the **OK** button to store the setting.



Table 2: Frost Protection Circulator Operation

Prestige Model	CH2 Pump/ System Pump	Auxillary Boiler Pump	DHW Pump	CH (1) Pump
Solo	ON	ON	OFF	ON
Excellence	ON	ON	OFF	OFF

Parallel Shift Value

Default: 0°F [0°C]

Parallel Shift allows the CH setpoint to be externally adjusted when a Constant option is chosen in CH Demand. When a Constant option is chosen in CH Demand, continuous CH1 and CH2 heating calls are generated. Simultaneous CH1 and CH2 calls will result in the Prestige operating at the highest CH1 or CH2 setpoint. The CH1 or CH2 Thermostat terminals with the highest setpoint will be used to adjust the setpoint. If the Thermostat terminals with the highest setpoint are open, the CH setpoint will decrease by the Parallel Shift Value. If the Thermostat terminals with the highest setpoint are closed, the CH setpoint will return to the highest CH1 or CH2 setpoint. Press the **LEFT** or **RIGHT** buttons to adjust the Parallel Shift Value then press the **OK** button to store the setting.

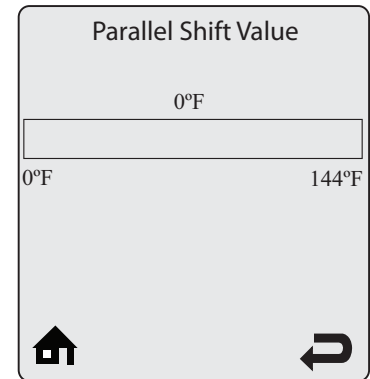

CH Call Blocking

Default: 1 Minute

CH Call Blocking sets the minimum time between burner firings for central heating calls. At the completion of a burner firing, the CH Call Blocking time will begin. The burner will not fire again until after the CH Call Blocking time has elapsed. The CH Call Blocking time only prevents the burner from firing, the central heating circulators will respond to a central heating call. This blocking time has no affect on domestic hot water calls. The CH Call Blocking feature prevents short cycling of the burner and extends the life of the burner components. Press the **LEFT** or **RIGHT** buttons to adjust the CH Call Blocking time then press the **OK** button to store the setting.

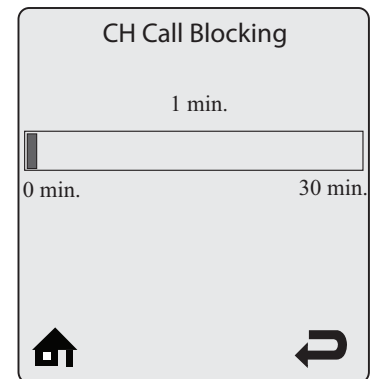

CH Settings

System Pump

Default: CH1/CH2

System Pump allows the system pump operation to be adjusted for the application. Press the **UP** or **DOWN** buttons to select the desired System Pump operation then press the **OK** button to store the setting. The System Pump options are:

- **CH1/CH2/DHW** – The system pump will be enabled for any CH1, CH2, or DHW call. Figure 2, page 11 illustrates a typical existing system requiring this setting.

Table 3: Circulator Operation with System Pump = CH1/CH2/DHW

	CH2 Pump/ System Pump	Auxillary Boiler Pump	DHW Pump	CH (1) Pump
CH 1 Call	ON	ON	OFF (Note 1)	ON
CH 2 Call	ON	ON	OFF (Note 1)	ON
DHW Call	ON	ON	ON	OFF (Note 1)

- **CH1/CH2** – The system pump will only be enabled for a CH1 or CH2 central heating call. Figure 3, page 12 illustrates a system zoned with zone valves requiring this setting.

Table 4: Circulator Operation with System Pump = CH1/CH2

	CH2 Pump/ System Pump	Auxillary Boiler Pump	DHW Pump	CH (1) Pump
CH 1 Call	ON	ON	OFF (Note 1)	ON
CH 2 Call	ON	ON	OFF	ON
DHW Call	OFF (Note 1)	ON	ON	OFF (Note 1)

- **CH2** – The system pump will only be enabled for a CH2 central heating call. The CH(1) pump will only be enabled for a CH1 central heating call. Figure 4, page 13 illustrates a system zoned with zone circulators requiring this setting.

Table 5: Circulator Operation with System Pump = CH2

	CH2 Pump/ System Pump	Auxillary Boiler Pump	DHW Pump	CH (1) Pump
CH 1 Call	OFF	ON	OFF (Note 1)	ON
CH 2 Call	ON	ON	OFF (Note 1)	OFF
DHW Call	OFF (Note 1)	ON	ON	OFF (Note 1)

Note 1: Domestic Hot Water Priority can be disabled which allows the CH and DHW circulators to operate at the same time.

NOTICE

The circulator operation shown above only applies when Prestige Model is set to Solo. System Pump only allows the system pump operation to be adjusted when Prestige Model is set to Excellence.

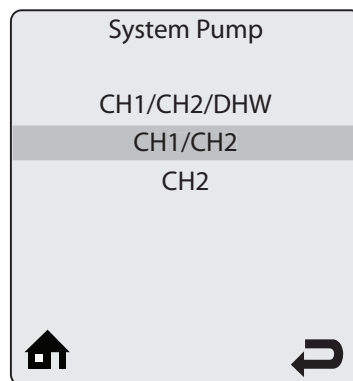

CH Settings

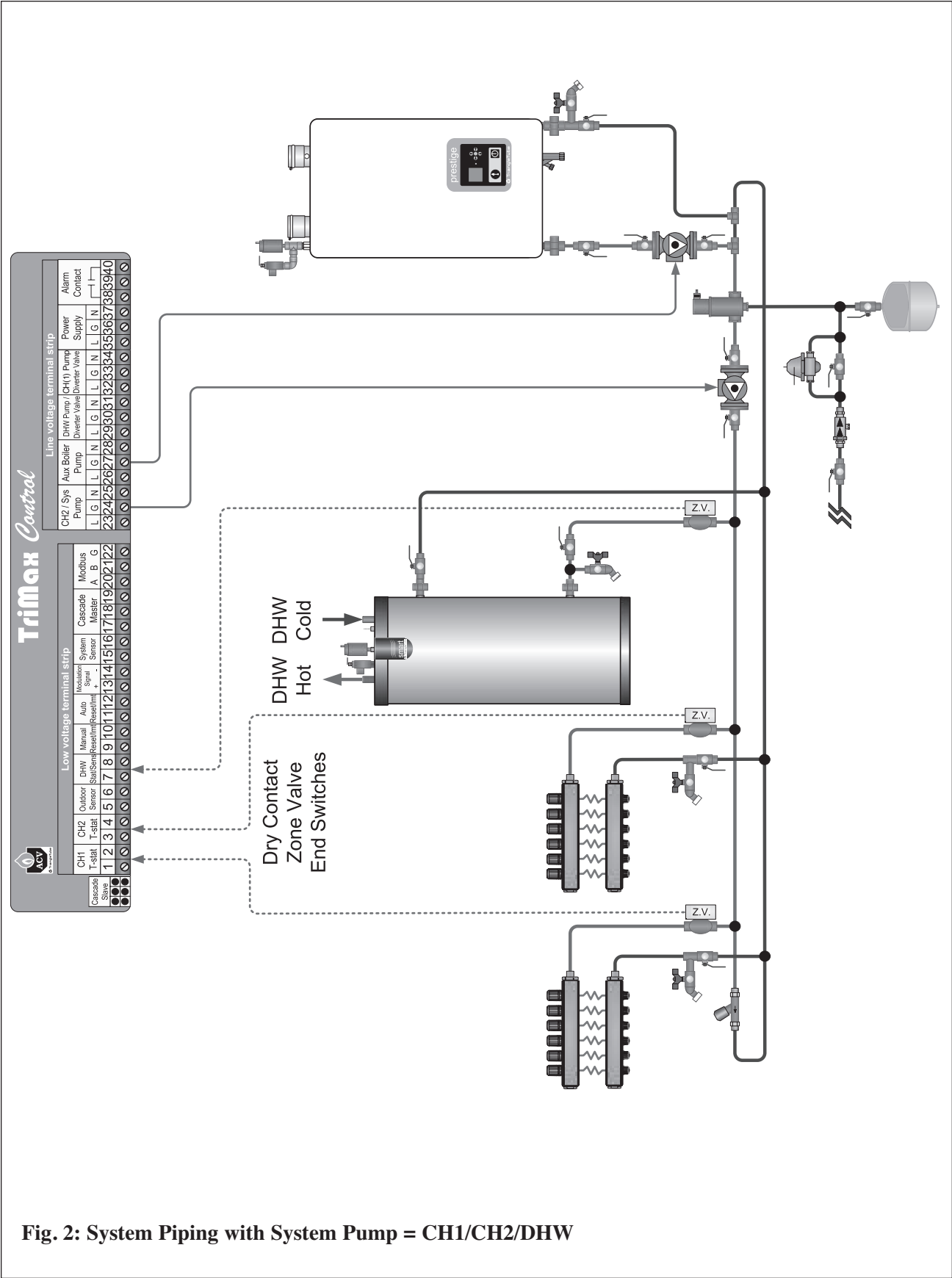

Fig. 2: System Piping with System Pump = CH1/CH2/DHW

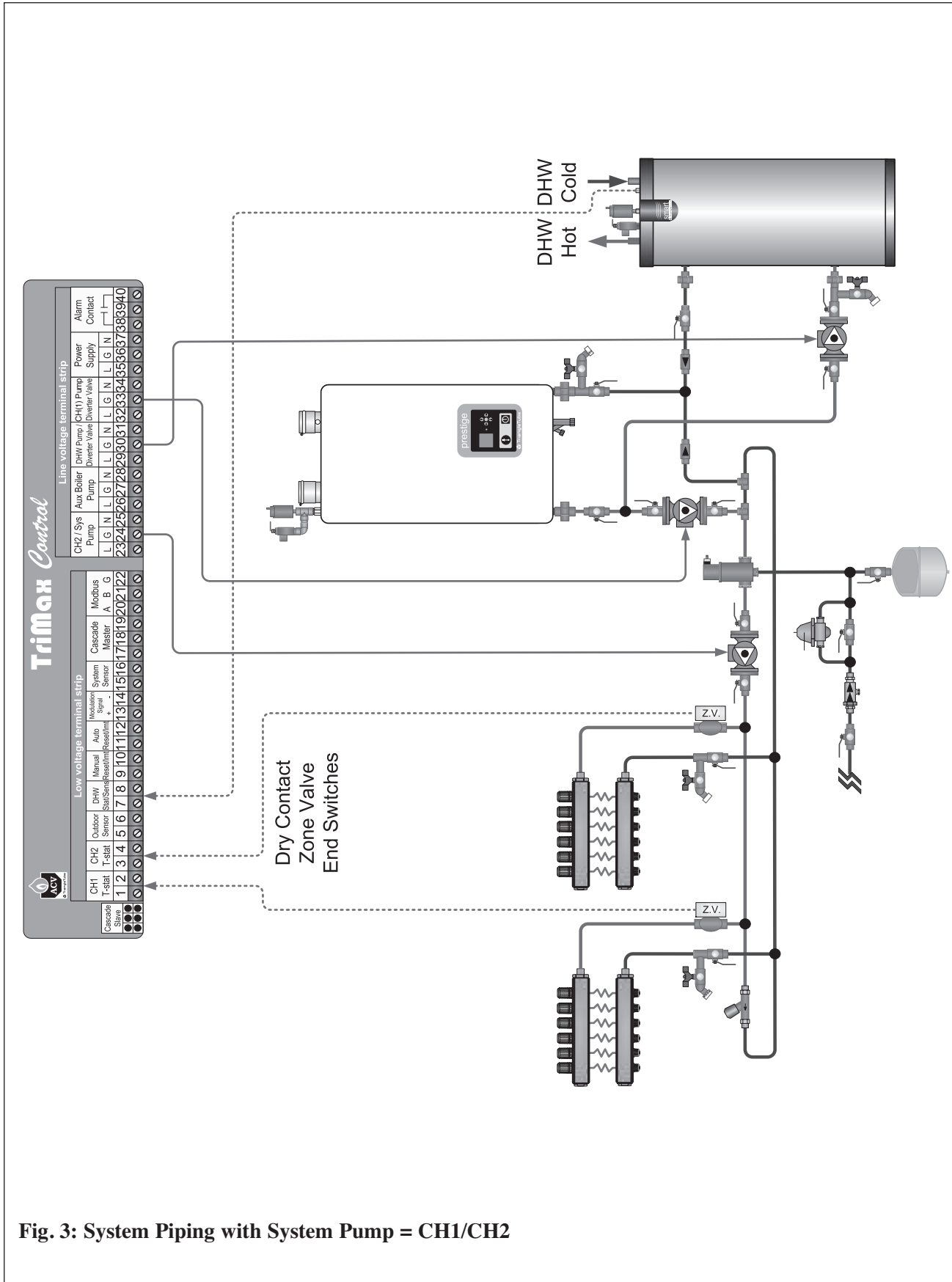

Fig. 3: System Piping with System Pump = CH1/CH2

DHW Settings

DHW Settings



Navigation: Home Screen>Installer Menu>CH & DHW Settings>DHW Settings

The DHW Settings menu contains settings related to domestic hot water operation. Each line contains a DHW Setting followed by its current value. Six DHW Settings are displayed on the screen at one time. Press the **UP** or **DOWN** buttons to scroll through additional DHW Settings.

DHW Settings	
DHW Operation	Enabled
Demand	Switch
Boiler DHW Setpoint	186°F
DHW Storage Setpoint	140°F
DHW On Differential	6°F
DHW Storage Adder	46°F

DHW Operation

Default: Enabled

DHW Operation allows the domestic hot water function to be enabled and disabled. Press the **UP** or **DOWN** buttons to select Enabled or Disabled then press the **OK** button to store the setting.

- **Enabled** - The Prestige will respond to a domestic hot water call.
- **Disabled** - The Prestige will not respond to a domestic hot water call. The domestic hot water operation disabled icon  is displayed on the home screen when domestic hot water operation has been disabled.

DHW Operation	
Disabled	
Enabled	

Demand Type

PRESTIGE Solo Default: Switch

PRESTIGE Excellence Default: Sensor

Demand Type allows the installer to select the type of device which will generate a domestic hot water call. Press the **UP** or **DOWN** buttons to select the DHW Demand Type then press the **OK** button to store the setting. The DHW Demand options are:

- **Switch** - A domestic hot water call from an aquastat or dry contact switch will enable the Prestige with a fixed setpoint for a domestic hot water call.
- **Sensor** - This option requires the use of Indirect Water Heater Sensor PSRKIT22 which is included with every PRESTIGE Solo. The PRESTIGE Excellence utilizes an Indirect Water Heater Sensor. The Prestige will monitor the DHW storage temperature and generate a domestic hot water call when the temperature drops below the DHW Storage Setpoint - DHW On Differential.

Demand Type	
Switch	
Sensor	

DHW Settings

Boiler DHW Setpoint

Default: 186°F [86°C]

Boiler DHW Setpoint is the fixed boiler setpoint temperature during a domestic hot water call when the Switch option is chosen in DHW Demand. Press the **LEFT** or **RIGHT** buttons to adjust the Boiler DHW Setpoint then press the **OK** button to store the setting.

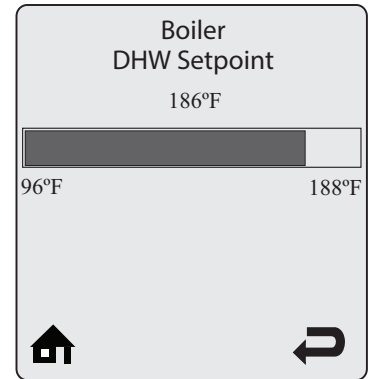

DHW Storage Setpoint

Default: 140°F [60°C]

DHW Storage Setpoint is the domestic hot water storage setpoint temperature when the Sensor option is chosen in DHW Demand. Press the **LEFT** or **RIGHT** buttons to adjust the DHW Storage Setpoint then press the **OK** button to store the setting.

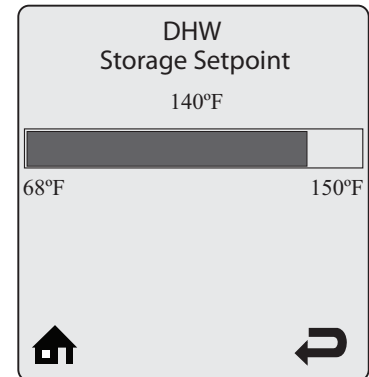

NOTICE

The boiler setpoint is automatically set to the DHW Storage Setpoint + DHW Storage Adder when the Sensor option is chosen in DHW Demand.

DHW On Differential

Default: 6°F [3°C]

DHW On Differential sets how far the DHW storage temperature must fall below the DHW Storage Setpoint to create a domestic hot water call when the Sensor option is chosen in DHW Demand. The domestic hot water call will end when the DHW storage temperature rises above the DHW Storage Setpoint. Press the **LEFT** or **RIGHT** buttons to adjust the DHW On Differential then press the **OK** button to store the setting.

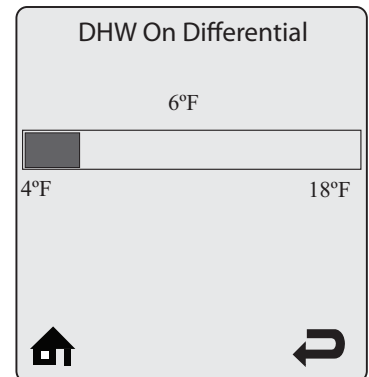

DANGER

The DHW On Differential setting greatly affects the production of domestic hot water. A low setting could result in a rapid response to a domestic hot water call resulting in a potential scald hazard. It is strongly recommended that the installer utilize a thermostatic mixing valve on the hot water outlet of the Indirect Water Heater. Failure to comply could result in severe personal injury, death, or substantial property damage.

DHW Settings

DHW Storage Adder

Default: 46°F [25°C]

DHW Storage Adder is used to compute the boiler setpoint when the Sensor option is chosen in DHW Demand. The boiler setpoint will be DHW Storage Setpoint + DHW Storage Adder for a domestic hot water call. Press the **LEFT** or **RIGHT** buttons to adjust the DHW Storage Adder then press the **OK** button to store the setting.

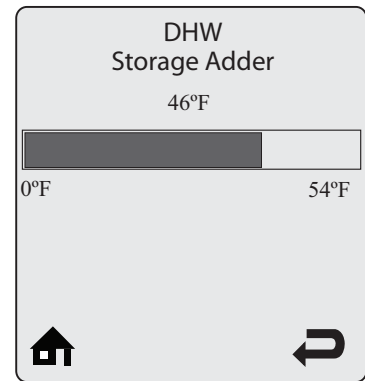

DHW Post Pump Time

Default: 1 Minute

DHW Post Pump Time sets how long the domestic hot water circulator will continue to operate at the completion of a domestic hot water call. Any call during the DHW Post Pump Time will be ignored until the post pump has completed. The DHW Post Pump feature allows the heat remaining in the boiler at the completion of a call to be sent to the Indirect Water Heater, which will improve the overall efficiency of the system. Press the **LEFT** or **RIGHT** buttons to adjust the DHW Post Pump Time then press the **OK** button to store the setting.

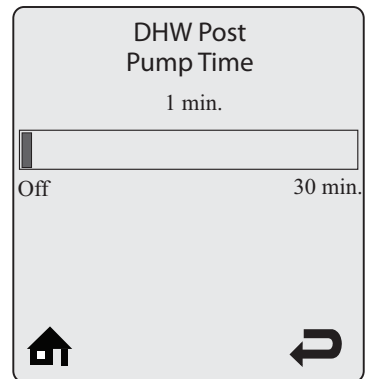

DHW Priority Timeout

Default: Off

DHW Priority Timeout allows the installer to enter an optional time limit that a domestic hot water call has priority over a central heating call when DHW Priority is set to Enabled. Press the **LEFT** or **RIGHT** buttons to adjust the DHW Priority Timeout then press the **OK** button to store the setting.

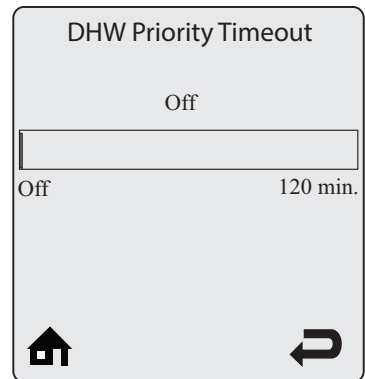

DHW Priority

Default: Enabled

DHW Priority allows the domestic hot water priority function to be enabled and disabled. Press the **UP** or **DOWN** buttons to select Enabled or Disabled then press the **OK** button to store the setting.

- **Enabled**- Domestic hot water calls will have priority over a central heating call. The boiler setpoint will be set to the domestic hot water setpoint during a domestic hot water call. The DHW circulator will be enabled and the heating circulators will be disabled during a domestic hot water call.
- **Disabled** - Domestic hot water calls will not have priority over a central heating call. The boiler setpoint will be set to the domestic hot water setpoint when only a domestic hot water call is present.

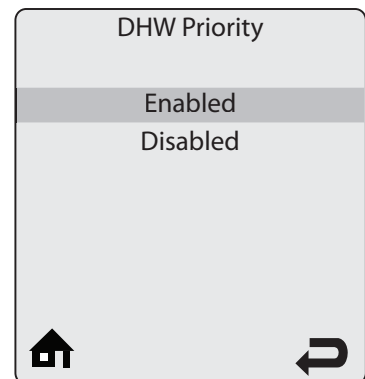

DHW Settings

The boiler setpoint will be set to the highest setpoint when simultaneous domestic hot water and central heating calls are present. The DHW circulator will be enabled during a domestic hot water call. The heating circulators will be enabled during a central heating call.

WARNING

Simultaneous domestic hot water and central heating calls will result in the PRESTIGE operating at the highest target temperature when DHW Priority is set to Disabled. The use of a mixing device on the lower temperature zones such as the Triangle Tube Optima Series SMV Control may be required to protect the lower temperature zones from damage.

NOTICE

DHW Priority should only be set to Disabled when Prestige Model is set to Solo. Setting DHW Priority to Disabled when Prestige Model is set to Excellence will not disable DHW Priority.

DHW Call Blocking

Default: 0 Minute

DHW Call Blocking sets the minimum time between burner firings for domestic hot water calls. At the completion of a burner firing, the DHW Call Blocking time will begin. The burner will not fire again until after the DHW Call Blocking time has elapsed. The DHW Call Blocking time only prevents the burner from firing, the domestic hot water circulator will respond to a domestic hot water call. This blocking time has no affect on central heating calls. The DHW Call Blocking feature prevents short cycling of the burner and extends the life of the burner components. Press the **LEFT** or **RIGHT** buttons to adjust the DHW Call Blocking time then press the **OK** button to store the setting.

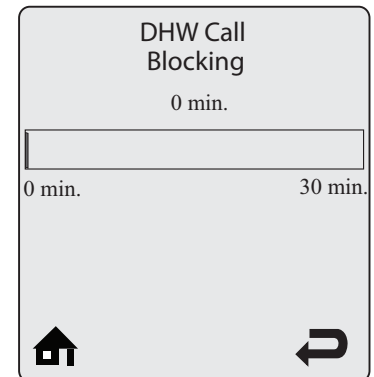

DHW To CH Call Blocking

Default: 1 Minute

DHW To CH Call Blocking sets the minimum time between a DHW burner firing and a CH burner firing. At the completion of a DHW burner firing, the DHW to CH Call Blocking time will begin. The burner will not fire again for a central heating call until after the DHW To CH Call Blocking time has elapsed. The DHW To CH Call Blocking time only prevents the burner from firing, the central heating circulators will respond to a central heating call. This blocking time has no affect on domestic hot water calls. The DHW To CH Call Blocking feature prevents the burner from firing when switching from a domestic hot water call to a central heating call. This allows the remaining heat in the heat exchanger to be dissipated and potentially satisfy the central heating call. Press the **LEFT** or **RIGHT** buttons to adjust the DHW To CH Call Blocking time then press the **OK** button to store the setting.

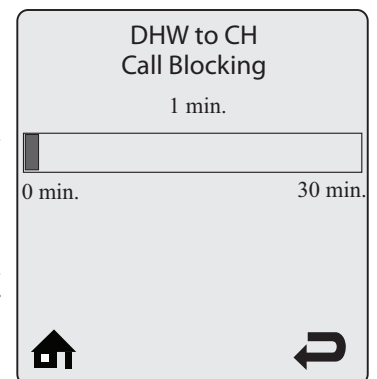

DHW Settings

Antilegionella Function

Default: Disabled

The Antilegionella Function ensures that an Indirect Water Heater is heated at least once per week to prevent the growth of Legionella bacteria. Press the **UP** or **DOWN** buttons to select Enabled or Disabled then press the **OK** button to store the setting.

- **Enabled**- When the Switch option is chosen in DHW Demand, a domestic hot water call is generated for 15 minutes once per week to heat the Indirect Water Heater. When the Sensor option is chosen in DHW Demand, a domestic hot water call is generated until the DHW storage temperature reaches 140°F [60°C] once per week. When the Sensor option is chosen in DHW Demand, the weekly timer is reset whenever the DHW storage temperature reaches 140°F [60°C] to prevent unnecessary firings. This function will be active even if DHW Operation has been set to Disabled.
- **Disabled** - The Prestige will only fire in DHW mode when a domestic hot water call is received.

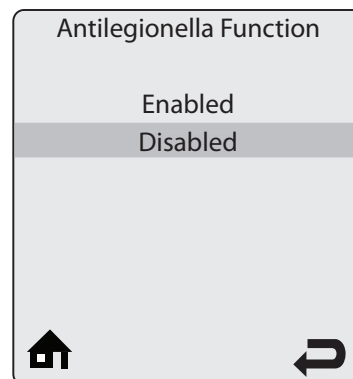

WARNING

The Antilegionella Function should only be enabled when an Indirect Water Heater is installed. Enabling the Antilegionella Function without an Indirect Water Heater will result in the Prestige firing once per week in DHW mode. This could cause a Manual Reset Hard Lockout resulting in substantial property damage.

BEST PRACTICE

The Antilegionella Function is most effective when the Sensor option is chosen in DHW Demand. The use of an Indirect Water Heater Sensor ensures that the domestic hot water is heated to 140°F [60°C] at least once per week.

Boiler Settings

Boiler Settings

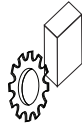

Navigation: Home Screen>Installer Menu>CH & DHW Settings>Boiler Settings

The Boiler Settings menu contains settings related to general boiler operation. Each line contains a Boiler Setting followed by its current value.

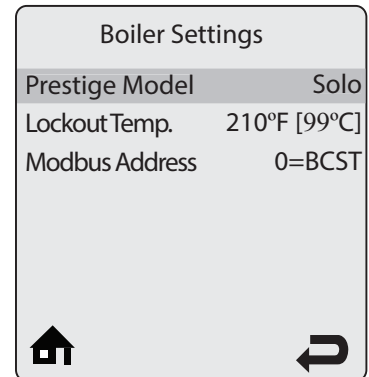

Prestige Model

PRESTIGE Solo Default: Solo
PRESTIGE Excellence Default: Excellence

Prestige Model selects how the circulator / diverter valve line voltage terminals will operate. Press the **UP** or **DOWN** buttons to select Solo or Excellence then press the **OK** button to store the setting.

- **Solo** - The circulator / diverter valve terminals can be used to operate CH(1), DHW, Auxiliary Boiler, and System circulators.
- **Excellence** - The CH(1), DHW, and Auxiliary Boiler circulator / diverter valve terminals will operate the internal boiler circulator and diverter valve. Only the System circulator terminals are available for operating a system circulator.



NOTICE

Excellence units also require setting Demand Type to Sensor for correct DHW operation.

Lockout Temp.

Default: 210°F [99°C]

Lockout Temp. allows the High Boiler Temperature lockout (E3) to be temporarily adjusted down to 102°F [39°C] for inspector demonstration. Press the **UP** or **DOWN** buttons to select 210°F [99°C] or 102°F [39°C] then press the **OK** button to store the setting.

- **102°F [39°C]** – A High Boiler Temperature lockout (E3) will occur when the boiler temperature reaches 102°F [39°C].
- **210°F [99°C]** – A High Boiler Temperature lockout (E3) will occur when the boiler temperature reaches 210°F [99°C].

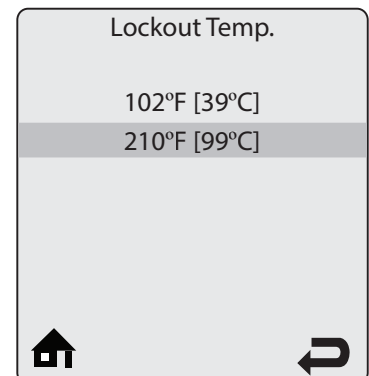

Reset All Settings

Modbus Address

Default:0=BCST

Modbus Address assigns the boiler with a unique address in the Modbus control system. Press the **LEFT** or **RIGHT** buttons to change the Modbus Address then press the **OK** button to store the setting. See Pages 41 & 42 for Modbus Interface information.

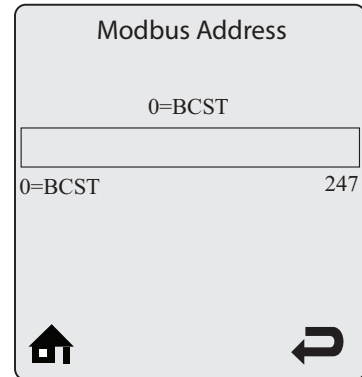

Reset All Settings

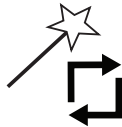

Navigation: Home Screen>Installer Menu>Reset All Settings

Reset All Settings allows the installer to reset all CH, DHW, Boiler and Cascade settings back to the original PRESTIGE Solo factory defaults. Follow the onscreen instructions to reset all settings back to the original factory defaults

NOTICE

PRESTIGE Excellence units require setting Prestige Model to Excellence and DHW Demand Type to Sensor after using the Reset All Settings function.

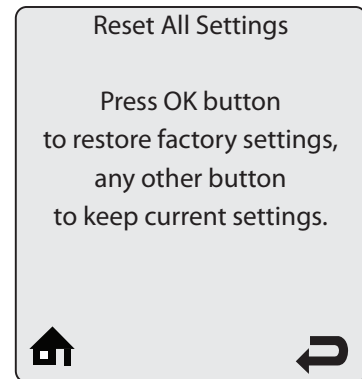

Factory Trimax Settings

Factory Trimax Settings

HEATING SETTING	FACTORY DEFAULT	MINIMUM SETTING	MAXIMUM SETTING	EZ SETUP RESET	INSTALLER RESET
Heating Operation	Enabled				✓
Demand	Switch & Outdoor Reset			✓	✓
Absolute Max CH Setpoint	188°F [87°C]	68°F [20°C]	188°F [87°C]		✓
CH1 Maximum Setpoint	180°F [82°C]	68°F [20°C]	188°F [87°C]	✓	✓
CH1 Minimum Setpoint	120°F [49°C]	60°F [15°C]	188°F [87°C]	✓	✓
Reset Curve Coldest Day	0°F [-18°C]	-30°F [-34°C]	50°F [10°C]		✓
Reset Curve Warmest Day	64°F [18°C]	60°F [15°C]	78°F [25°C]		✓
CH2 Circuit	Enabled				✓
CH2 Maximum Setpoint	140°F [60°C]	68°F [20°C]	188°F [87°C]	✓	✓
CH2 Minimum Setpoint	80°F [27°C]	60°F [15°C]	188°F [87°C]	✓	✓
Warm Weather Shutdown	OFF	OFF	78°F [25°C]	✓	✓
Pump Constant Circulation	Disabled				✓
CH Post Pump Time	1 minute	OFF	20 minute		✓
Freeze Protection	Enabled				✓
Frost Protection Setpoint	-22°F [-30°C]	-22°F [-30°C]	50°F [10°C]		✓
Parallel Shift Value	0°F [0°C]	0°F [0°C]	144°F [80°C]		✓
CH Call Blocking	1 minute	0 minute	30 minutes		✓
System Pump	CH1/CH2				✓
DOMESTIC SETTING	FACTORY DEFAULT	MINIMUM SETTING	MAXIMUM SETTING	EZ SETUP RESET	INSTALLER RESET
DHW Operation	Enabled				✓
Demand	Switch			✓	✓
Boiler DHW Setpoint	186°F [86°C]	96°F [35°C]	188°F [87°C]	✓	✓
DHW Storage Setpoint	140°F [60°C]	68°F [20°C]	150°F [65°C]	✓	✓
DHW On Differential	6°F [3°C]	4°F [2°C]	18°F [10°C]		✓
DHW Storage Adder	46°F [25°C]	0°F [0°C]	54°F [30°C]		✓
DHW Post Pump Time	1 minute	OFF	30 minutes		✓
DHW Priority Timeout	OFF	OFF	120 minutes	✓	✓
DHW Priority	Enabled				✓
DHW Call Blocking	0 minute	0 minute	30 minutes		✓
DHW to CH Call Blocking	1 minute	0 minute	30 minutes		✓
Antilegionella Function	Disabled				✓
BOILER SETTING	FACTORY DEFAULT	MINIMUM SETTING	MAXIMUM SETTING	EZ SETUP RESET	INSTALLER RESET
Prestige Model	Solo				✓
Lockout Temperature	210°F [99°C]				✓
Modbus Address	0=BCST	0	247		✓
CASCADE SETTING	FACTORY DEFAULT	MINIMUM SETTING	MAXIMUM SETTING	EZ SETUP RESET	INSTALLER RESET
Stage Delay	60 seconds	0 second	255 seconds		✓
Minimum Firing Rate	30%	0%	100%		✓
Maximum Firing Rate	398 MBH [117kW]	0 MBH [0kW]	869 MBH [255kW]		✓
CH / DHW Boilers	0	0	6		✓
Automatic Rotation	Enabled				✓
CH Proportional Gain	7	1	255		✓
CH Integral Gain	245	1	255		✓
DHW Proportional Gain	7	1	255		✓
DHW Integral Gain	245	1	255		✓



Cascade Operating Information

Cascade Operating Information

The TriMax Boiler Management System includes a Cascade function which allows multiple Prestige boilers to operate together without the need for an external controller. One Prestige will be selected as the Master and will be wired to accept all the low voltage control signals. The other Prestige boilers will be designated as Slaves and will only have a communication cable connecting them to the other boilers in the Cascade System.

- The Cascade function allows up to six identical Prestige boilers to operate together in a single heating system.
- Parallel Modulation fires as many boilers as possible to maximize system efficiency.
- Lead Stage Automatic Rotation rotates the lead boiler to ensure even wear on each boiler in the Cascade System. This function can be disabled by the Automatic Rotation Setting.

The Cascade Menu is divided into three sections

1. Cascade Information  – Provides real time operating information of the Cascade System. See page 34.
2. Cascade Settings  – Allows the installer to adjust the Cascade System settings for the application. See pages 35 through 40.
3. Cascade Autodetection  – Automatically finds and configures each boiler of the Cascade System. See page 26.

Trimax Cascade Menu Structure

Trimax Cascade Menu Structure

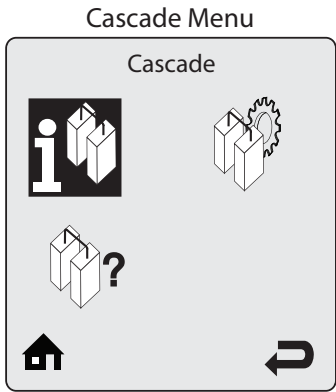
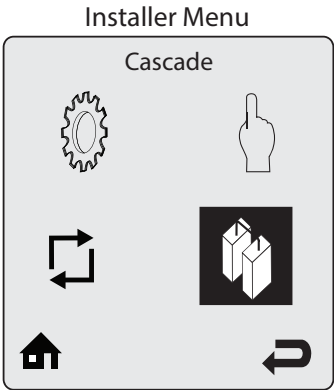

Cascade Information Menu

Cascade Information	
Cascade Role	Master
System Temp.	86°F
Active Boilers	0
Total Boilers	2
Cascade Firing Rate	--



Cascade Settings Menu

Cascade Settings	
Stage Delay	60 sec
Minimum Firing Rate	30%
Maximum Firing Rate	398 MBH
CH / DHW Boilers	0
Automatic Rotation	Enabled
CH Proportional Gain	7



Cascade Autodetection

Cascade Autodetection

Press OK Button to begin Cascade Autodetection, any other button to cancel

Cascade Installation

Cascade Installation – System Piping

Standard Cascade installations will utilize a balanced manifold system as the primary / secondary connection to the system piping as shown in Figure 7, page 28 or a reverse return piping arrangement as shown in Figure 9, page 30. Split Cascade installations will utilize a balanced manifold system as the primary / secondary connection to the central heating loop. Each boiler configured to respond to a domestic hot water call will also have a direct connection to the indirect water heater as shown in Figure 11, page 32. Reference the Prestige Installation and Maintenance Manual for general boiler installation and piping requirements.

Cascade Installation – System Sensor Installation

Cascade operation requires a System Temperature Sensor to be installed on the common supply header downstream of all boilers in the system. Place the System Temperature Sensor within 10' of the last boiler in the Cascade System for an accurate temperature reading. Proper placement and installation of the System Temperature Sensor is critical for reliable cascade operation. The type of System Temperature Sensor chosen also greatly affects the accuracy of the system temperature readings.

Three types of System Temperature Sensor are available:

- Direct Immersion - A direct immersion temperature sensor (MDRKIT05) is the recommended type since it will provide the most accurate water temperature readings. Install the 1/2" NPT direct immersion temperature sensor in a tee on the common supply header downstream of all boilers in the system. Ensure that the temperature sensor probe is directly in the water flow but not touching the opposite side of the tee. Wire the sensor to terminals 15 & 16 of the Master boiler.
- Dry Well Installation – A temperature sensor (PSRKIT22) installed in a dry well will measure up to 10°F [5°C] lower than the actual water temperature. All water setpoints must be lowered at the Master boiler by 10°F [5°C] from the desired setpoints for reliable Cascade operation. Install a 3/8" ID drywell in the common supply header downstream of all boilers in the system. The drywell should be long enough to be directly in the water flow for the most accurate temperature reading. Insert the temperature sensor into the well and wire to terminals 15 & 16 of the Master boiler.
- Pipe Mounted Installation – A temperature sensor (PTSENS12) mounted to the outside of the pipe will measure up to 20°F [11°C] lower than the actual water temperature. All water setpoints must be lowered at the Master boiler by 20°F [11°C] from the desired setpoints for reliable Cascade operation. The Pipe Mounted temperature sensor can be directly strapped to the outside of a 1" to 3" metallic pipe. Install the temperature sensor as follows:
 1. Remove the white plastic cover from the sensor
 2. Cut a small slit in the seal gasket on the end of the sensor.

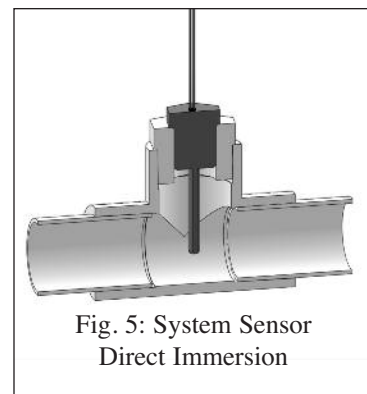

Fig. 5: System Sensor
Direct Immersion

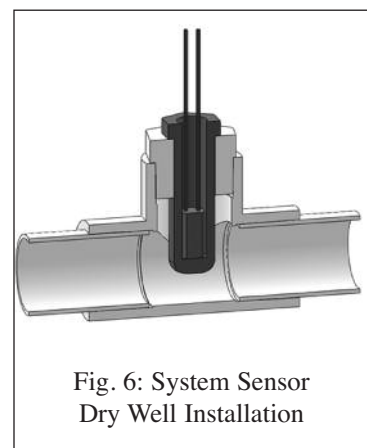

Fig. 6: System Sensor
Dry Well Installation

Cascade Installation

3. Route 18 AWG 2-wire cable or similar cable through the seal gasket into the enclosure.
4. Push down on the orange wire terminal retainers to insert the wires into the sensor terminals. Release the orange wire terminal retainers and confirm that the wires are firmly attached to the sensor terminals.
5. Select a location for the sensor on the common supply header downstream of all boilers in the system. Clean the pipe with fine sandpaper or emery cloth to ensure the pipe is clean and sensor will make good contact with the pipe.
6. Press the white cover onto the sensor and strap the sensor to the pipe using the included wire tie.
7. Wire the sensor to terminals 15 & 16 of the Master boiler.

Cascade Installation – Cascade Communication Cable

- A communication cable PTCAB01 must be installed between each boiler in the Cascade System. The cable has a 6 pin molex connector on one end and bare wires on the other end. The molex connector plugs into the Cascade Slave connector of the Slave boiler. The bare wires terminate on the Cascade Master terminals of the Master boiler or prior Slave boiler in cascades of three or more boilers. Reference Figure 8,10,12 on pages 29, 31, 33 for wiring details. The connections are as follows:

Red Wire to Terminal #17

White Wire to Terminal #18

Black Wire & Cable Shielding to Terminal #19

Cascade Installation – Low Voltage Wiring Connections

- Thermostat Wiring – CH1 and CH2 calls must be wired into the Cascade Master.
- Outdoor Sensor Wiring – The outdoor temperature sensor must be wired into the Cascade Master.
- Domestic Hot Water Wiring – A DHW call must be wired into the Cascade Master.
- Additional Boiler Limits – Boiler Limits must be wired into each boiler in the Cascade System. When a boiler limit opens, that particular boiler will lockout and will be removed from Cascade System operation. The other boilers in the Cascade System will continue to operate if they are not in a lockout.
- External Modulation Control – An External Modulation Signal must be wired into the Cascade Master. The modulation signal will control the firing rate of the entire Cascade System, not just the Cascade Master.
- Modbus Wiring – A building management system (BMS) connection must be wired into the Cascade Master.

Cascade Installation

Cascade Installation – Line Voltage Wiring Connections

- Circulator Wiring - Reference Figures 8,10,12 on pages 29, 31, 33 for circulator wiring required for each type of Cascade System. The circulator connections used will depend on the systems piping layout.

NOTICE

Each circulator is individually fused with a 2.5A fuse located in the terminal strip. The total combined amp draw of the CH (1), DHW, and Auxiliary Boiler Circulators must not exceed 4 amps at any time for the PRESTIGE Solo 60, 110, 175, or 250. The total combined amp draw of the CH (1), DHW, and Auxiliary Boiler Circulators must not exceed 3 amps at any time for the PRESTIGE Solo 399. Use an isolation relay to lower the total combined amp draw if exceeding these limits.

- Power Supply – A dedicated 120 VAC / 15A minimum service must be used to power the boilers in the Cascade System. Multiple boilers in the Cascade System can be placed on the same electrical circuit. Each boiler can draw a maximum of 8 amps.
- Alarm Wiring – The alarm contact closes whenever that particular Prestige is in a soft or hard lockout. The alarm contact will also close on the Master boiler when any of the Slave boilers are locked out.

Cascade Installation – Cascade Autodetection

Navigation: Home Screen>Installer Menu>Cascade>Cascade Autodetection

The Cascade System must be configured after wiring is completed and any required adjustments are made in Cascade Settings. The Cascade Autodetection function automatically finds and configures all boilers in the Cascade System. This eliminates the need to manually configure each boiler of the Cascade System. Select Cascade Autodetection on the Master boiler then follow the onscreen instructions to perform Cascade Autodetection. Once Cascade Autodetection is finished, a message will be displayed indicating how many boilers have been found. If the number of boilers found is correct, press **OK** to finish Cascade Autodetection. If the number of boilers found is not correct, check the cascade communication cables between the boilers and repeat Cascade Autodetection.

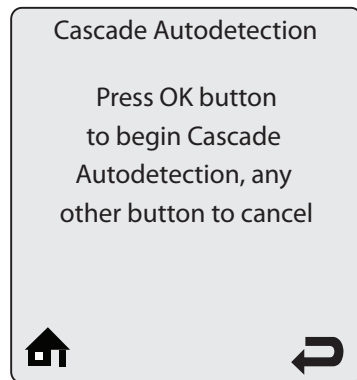

Cascade Installation

Cascade Operation – Lockouts

If a lockout occurs to a boiler in a Cascade System, it will be removed from Cascade System operation. The remainder of the Cascade System continues to operate and the next available boiler will fire if necessary. The Lockout Screen will be displayed on the locked out boiler as well as the Master boiler. The Master boiler Lockout Screen will also indicate which boiler in the Cascade System is locked out.

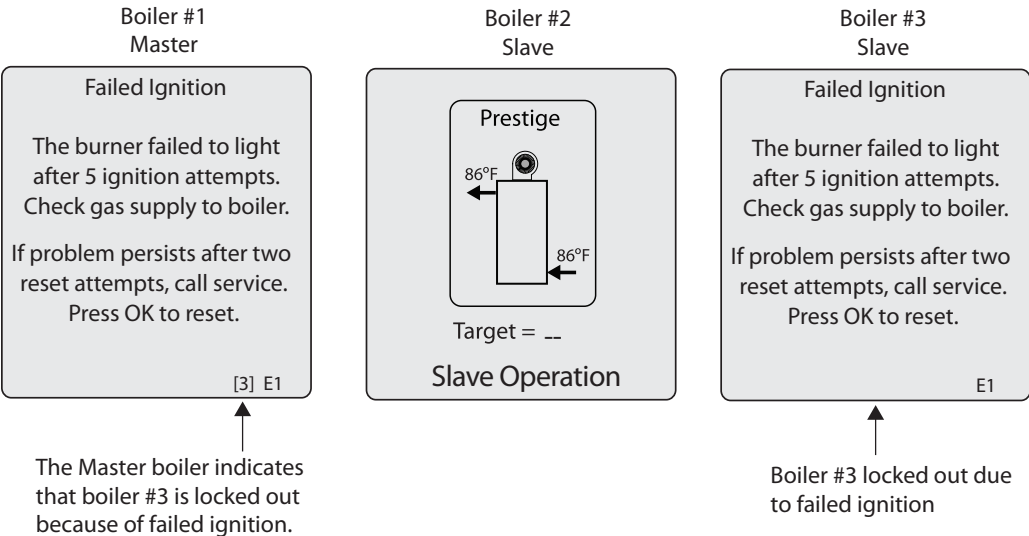

Cascade Installation

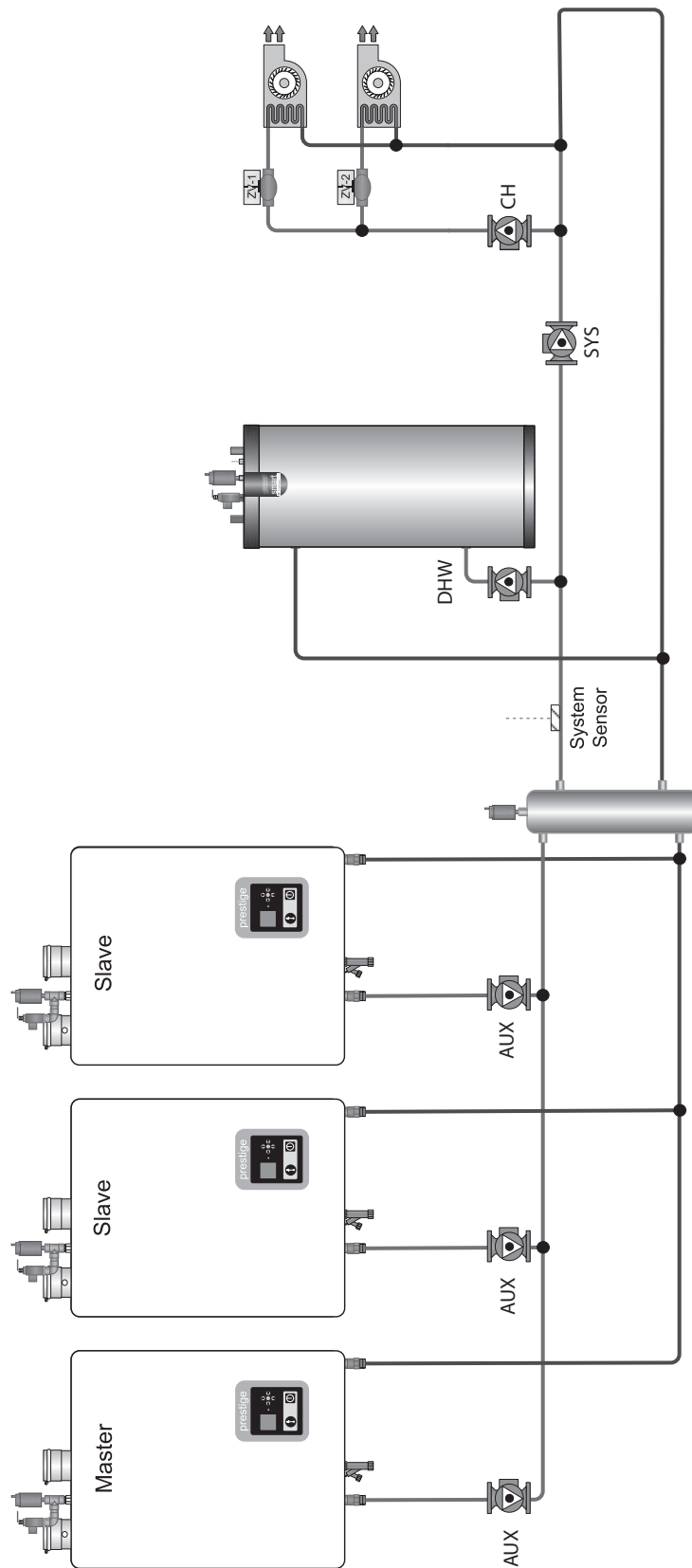
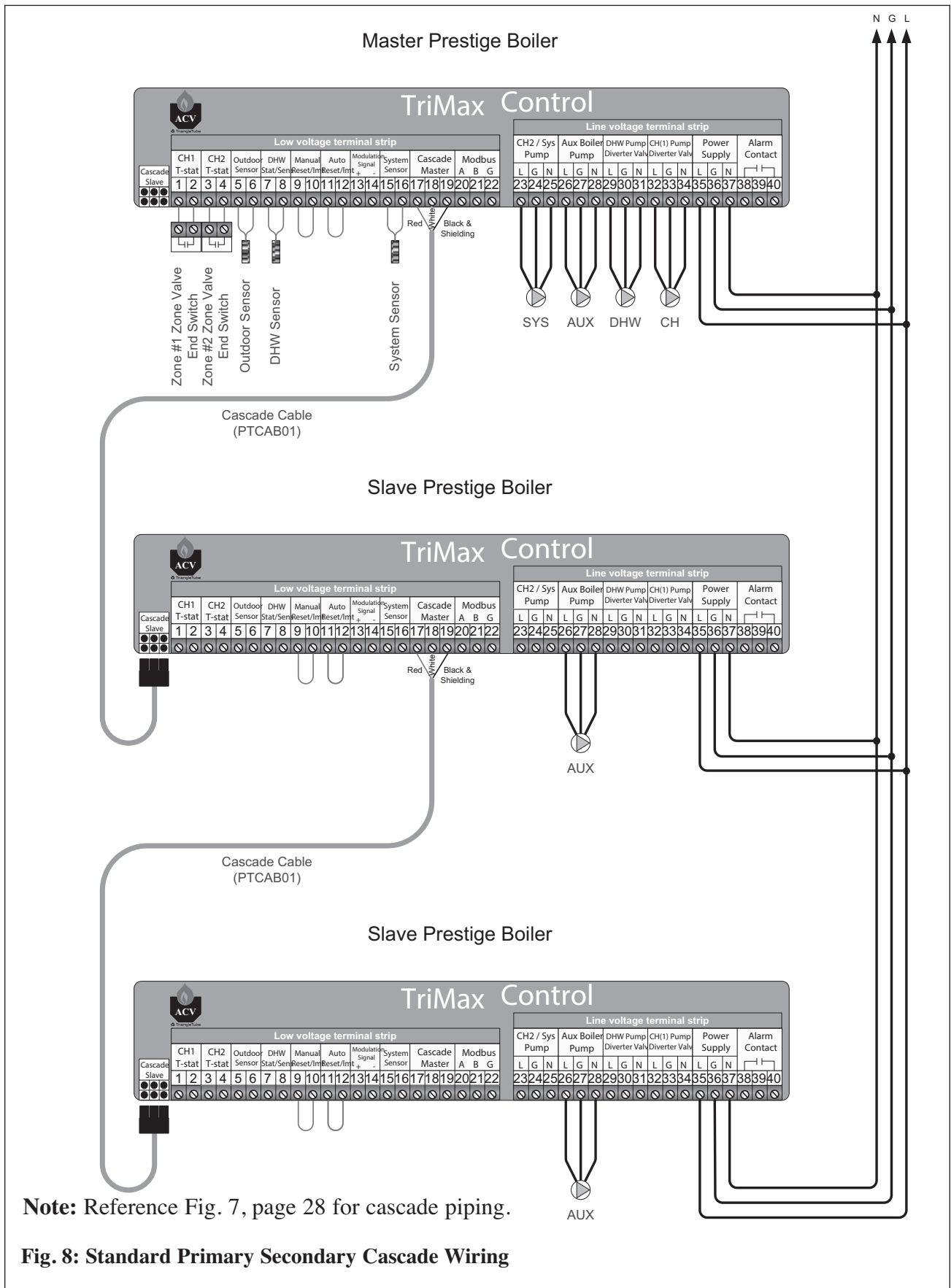

Fig. 7: Standard Primary Secondary Cascade System

Note: Reference Fig. 8, page 29 for cascade wiring.

Cascade Installation



Cascade Installation

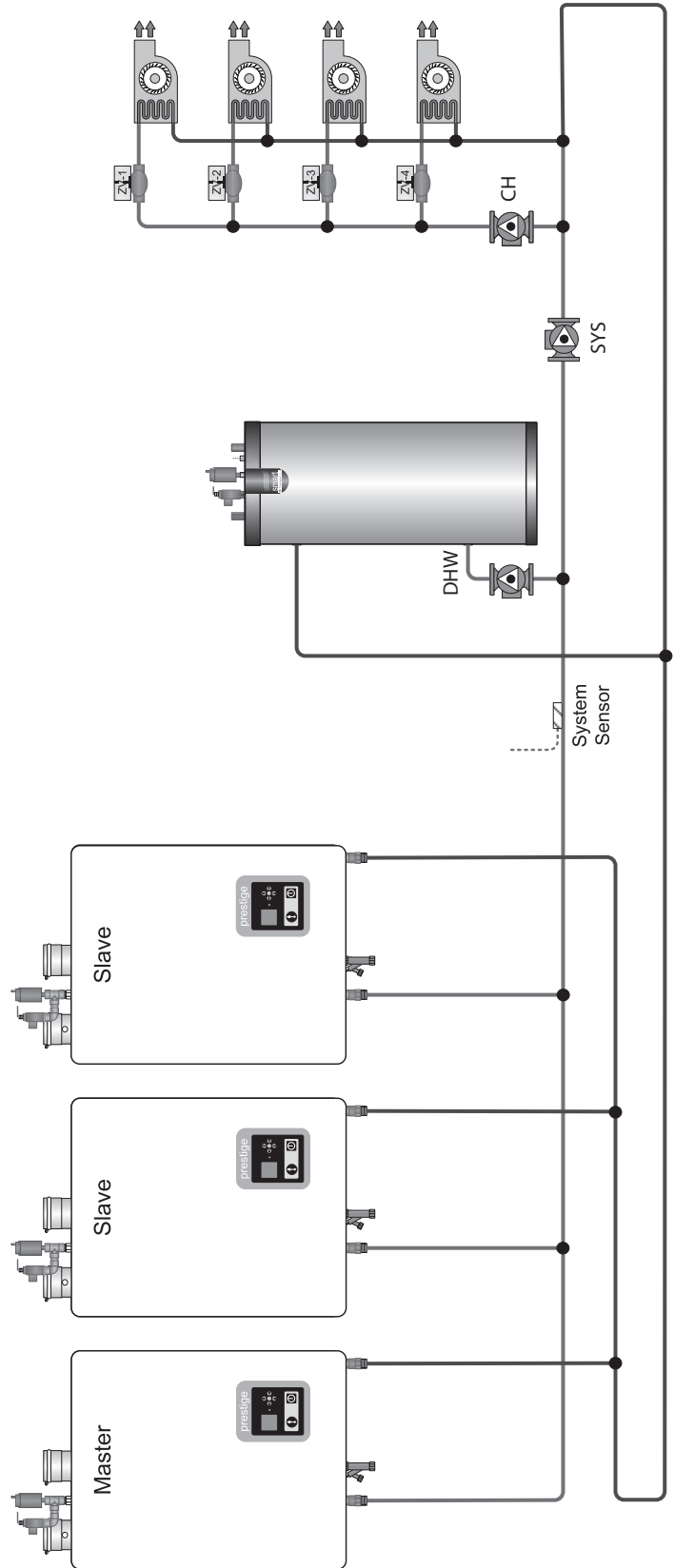
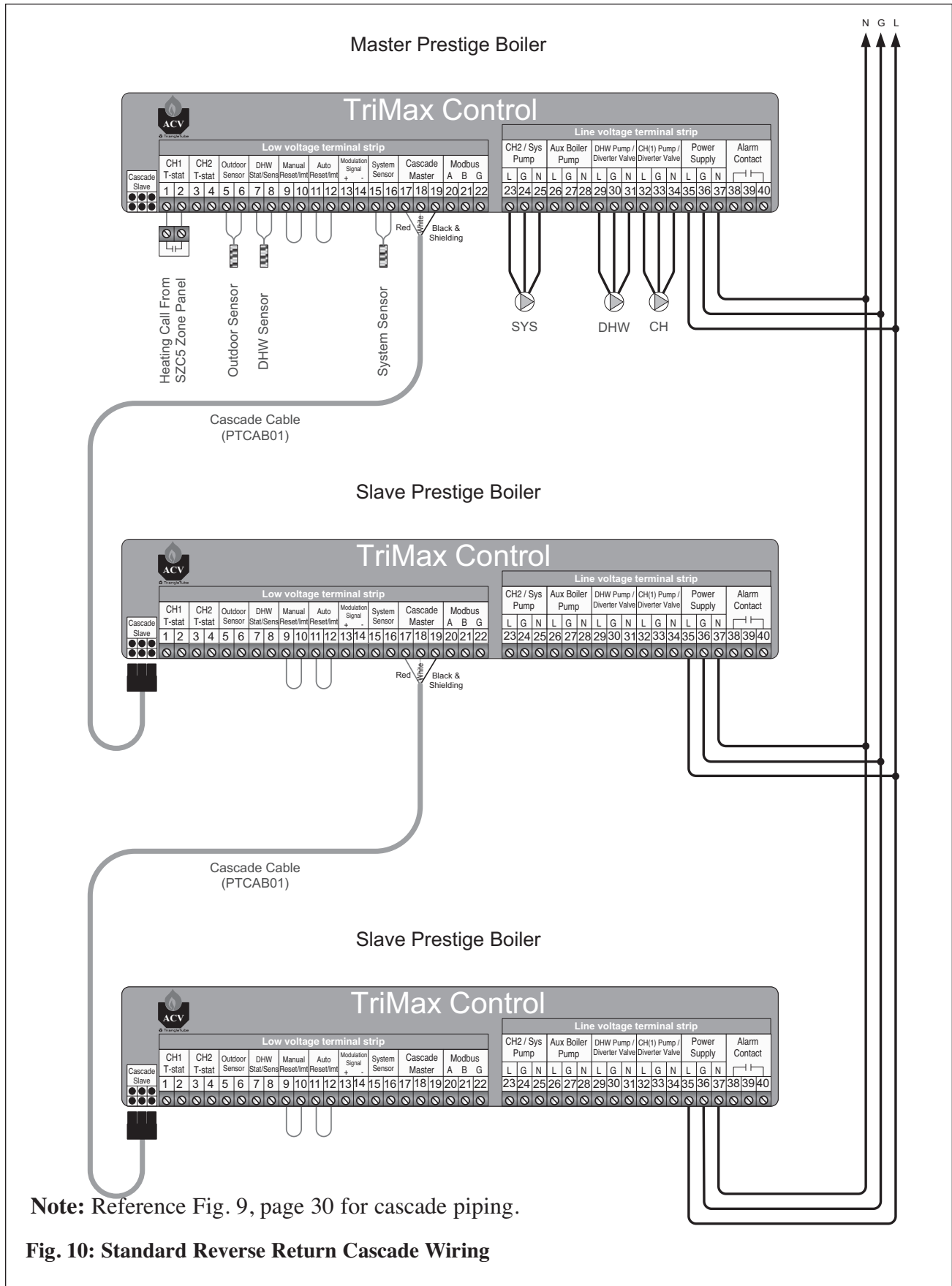

Fig. 9: Standard Reverse Return Cascade System

Note: Reference Fig. 10, page 31 for cascade wiring.

Cascade Installation



Note: Reference Fig. 9, page 30 for cascade piping.

Fig. 10: Standard Reverse Return Cascade Wiring

Cascade Installation

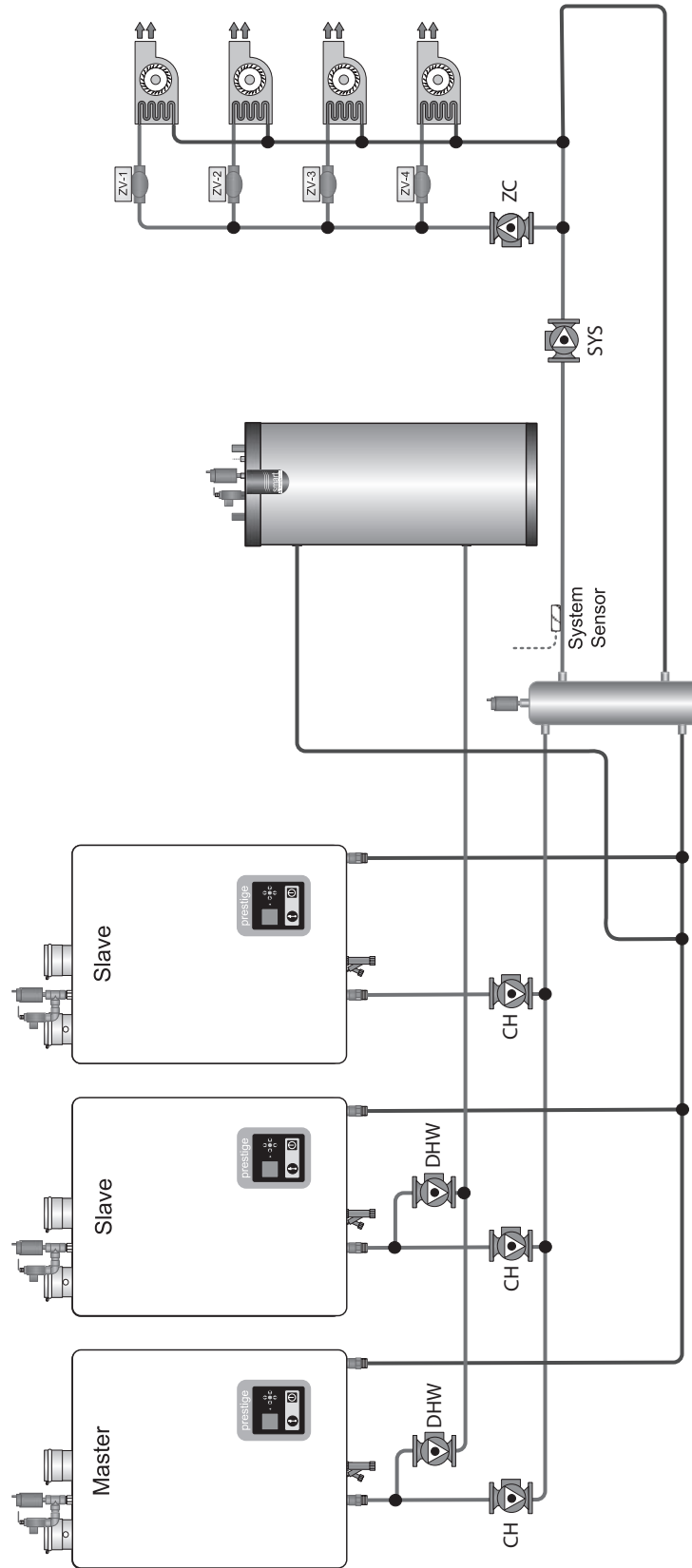
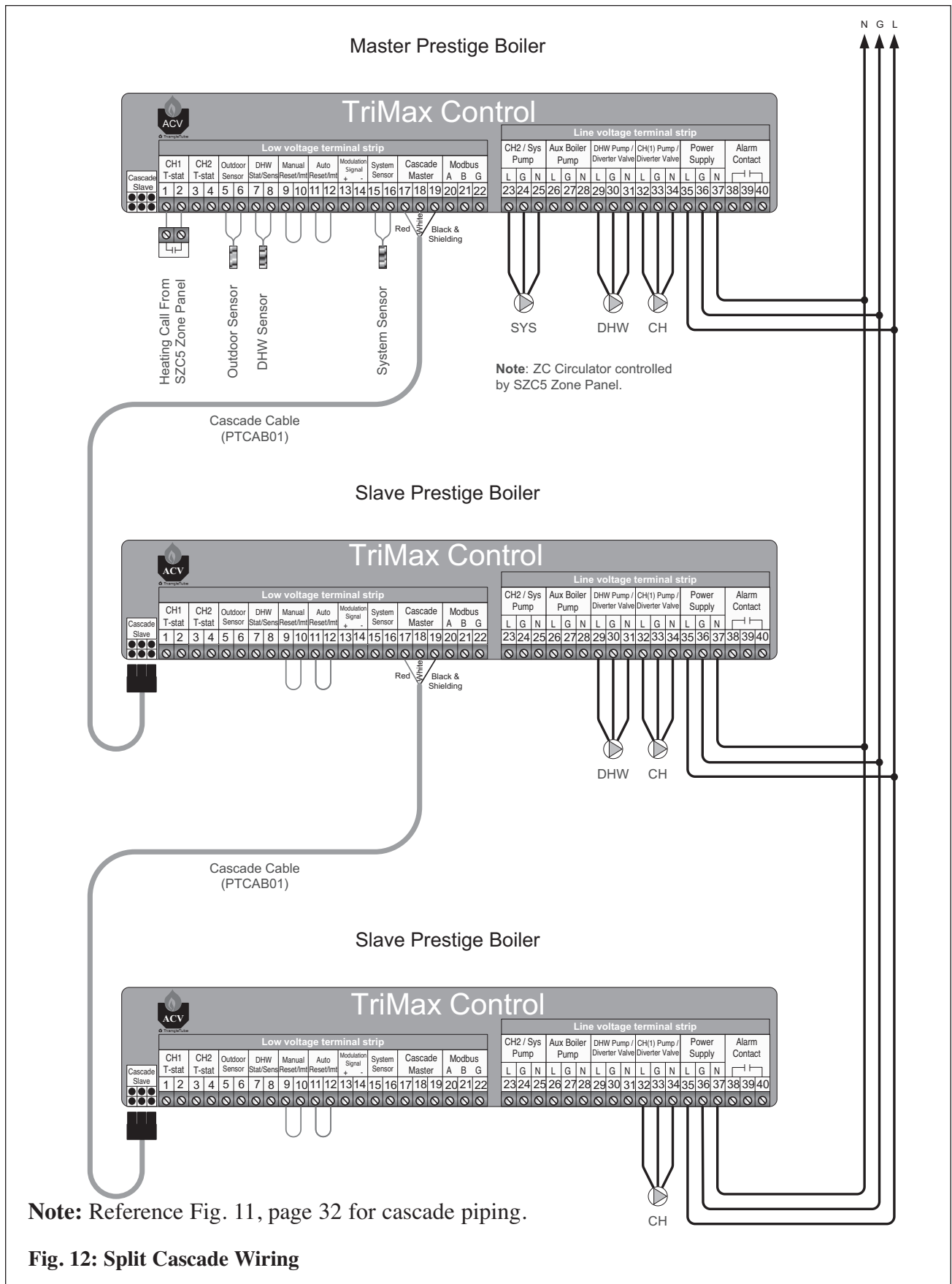

Fig. 11: Split Cascade System

Note 1: Reference Fig. 12, page 33 for cascade wiring.

Note 2: DHW Priority must be set to Enabled in DHW Settings of the Cascade Master for proper operation.

Cascade Installation



Cascade Information

Cascade Information

Navigation: Home Screen>Installer Menu>Cascade>Cascade Information

Cascade Information provides real time operating information of the Cascade System. Each line contains an information item followed by its current value. See below for a list of all Cascade Information items.

Cascade Information	
Cascade Role	Master
System Temp.	86°F
Active Boilers	0
Total Boilers	2
Cascade Firing Rate	--

System Temperature Logging

System Temperature has a logging function which records one sample every 12 minutes to produce a graph of the last 24 hours. Select System Temperature in Cascade Information then press the **OK** button to view the graph.

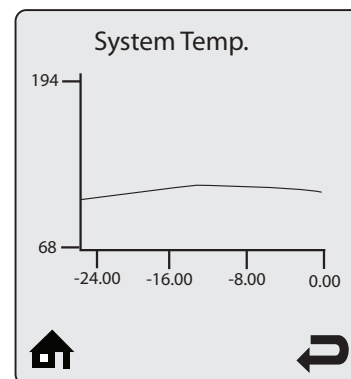

Cascade Information Items

Information Item	Description
Cascade Role	Displays the current role of the Prestige in the Cascade System. Cascade Role will be one of the following: <ul style="list-style-type: none"> Master – Indicates this Prestige is the Master boiler in the Cascade System. Slave – Indicates this Prestige is a Slave boiler in the Cascade System. Standalone – Indicates this Prestige is not part of a Cascade System.
System Temperature	Displays the current system temperature reading wired to the Master boiler. If the system sensor is not wired in to the Master boiler, "--" is displayed.
Active Boilers	Displays the current number of boilers fired in the Cascade System.
Total Boilers	Displays the total number of boilers in the Cascade System.
Cascade Firing Rate	Displays the current firing rate of the entire Cascade System.

Cascade Settings

Cascade Settings



Navigation: Home Screen>Installer Menu>Cascade>Cascade Settings

The Cascade Settings menu contains settings related to cascade operation. Each line contains a Cascade Setting followed by its current value. Six Cascade Settings are displayed on the screen at one time. Press the **UP** or **DOWN** buttons to scroll through additional Cascade Settings.

NOTICE

Cascade Setting changes must be made on the Cascade Master. Cascade Autodetection must be performed after making any changes to a Cascade Setting before the change will take effect.

Stage Delay

Default: 60 Seconds

Stage Delay sets the time delay before enabling or disabling a boiler in the Cascade System. The Stage Delay begins once the Master boiler determines that a boiler must be enabled to reach the setpoint or when the Master boiler determines a boiler should be disabled because of a decreasing load. Press the **LEFT** or **RIGHT** buttons to adjust the Stage Delay then press the **OK** button to store the setting. Adjusting the Stage Delay will have the following effects:

- **Increase Stage Delay**

- Reaching the setpoint could take longer due to a longer delay between enabling boilers.
- Overshooting the setpoint could occur due to boilers staying on longer before being disabled.

- **Decrease Stage Delay**

- Overshooting the setpoint could occur due to boilers being enabled quicker.
- Boilers will be disabled quicker, possibly increasing boiler cycling and decreasing runtimes.

Minimum Firing Rate

Default: 30%

Minimum Firing Rate is the minimum firing rate of a single boiler in the Cascade System. The Master boiler uses this setting to determine when boilers can be enabled and disabled. Setting the Minimum Firing Rate below the recommended minimum will result in boilers being enabled too quickly which may cause sharp increases in temperature from the Cascade System. Setting the Minimum Firing Rate above the recommended minimum will delay the enabling of boilers which may lower the system efficiency. Press the **LEFT** or **RIGHT** buttons to adjust the Minimum Firing Rate then press the **OK** button to store the setting. The minimum recommended settings are:

Prestige Model	Minimum Firing Rate
Solo 60	28%
Solo 110 Natural Gas	29%
Solo 110 Propane Gas	27%
Solo 175	31%
Solo 250	28%
Solo 399	30%

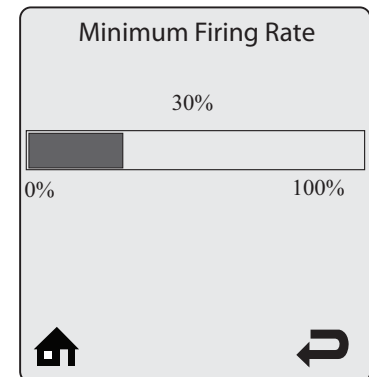
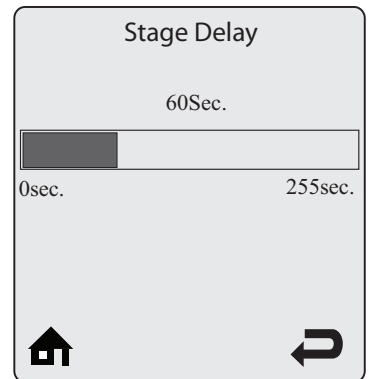
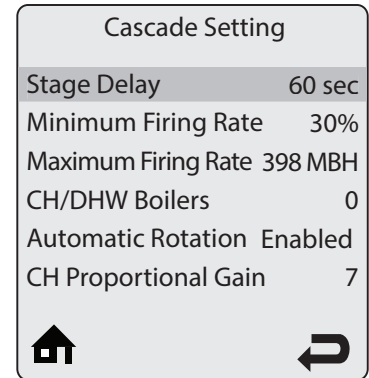

Cascade Settings

Boiler Enabling Algorithm

The Master boiler uses the following algorithm to determine when the next boiler can be enabled:

$$\frac{\text{Number of Boilers Firing} + 1}{\text{Number of Boilers Firing}} \times \text{Minimum Firing Rate} = \text{Individual Boiler Firing Rate}$$

Once the currently fired boilers reach the calculated firing rate, the next boiler can be enabled without affecting the overall cascade firing rate. For example, the calculation for a Cascade System consisting of two PRESTIGE Solo 399s would be:

$$\frac{1 + 1}{1} \times 30\% = 60\%$$

Once the first PRESTIGE Solo 399 firing rate reaches 60%, the second PRESTIGE Solo 399 can be enabled. Both will then fire at the minimum 30% firing rate so that the overall output from the Cascade System remains the same.

Boiler Disabling Algorithm

Once the firing rate of all currently fired boilers decreases to the Minimum Firing Rate, a boiler can be disabled. The boilers which continue to fire will increase their firing rate if required to replace the output of the disabled boiler.

NOTICE

Stable cascade operation requires that all boilers in a Cascade System be the same size. Mixing boiler sizes in a Cascade System could lead to temperature fluctuations and erratic cascade operation.

Maximum Firing Rate

Default: 398 MBH

Maximum Firing Rate is the maximum firing rate of a single boiler in the Cascade System. Press the **LEFT** or **RIGHT** buttons to adjust the Maximum Firing Rate then press the **OK** button to store the setting. The recommended settings are:

Prestige Model	Maximum Firing Rate
Solo 60	57 MBH
Solo 110 Natural Gas	109 MBH
Solo 110 Propane Gas	95 MBH
Solo 175	170 MBH
Solo 250	245 MBH
Solo 399	398 MBH

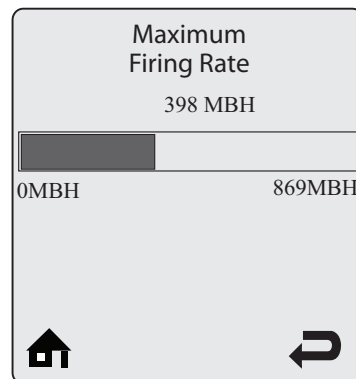

NOTICE

Stable cascade operation requires that all boilers in a Cascade System be the same size. Mixing boiler sizes in a Cascade System could lead to temperature fluctuations and erratic cascade operation.

Cascade Settings

CH/DHW Boilers

Default: 0

The CH/DHW Boilers setting specifies how many boilers in a Split Cascade System will respond to a domestic hot water call. The CH/DHW Boilers always include the Master boiler. The remaining boilers will only respond to central heating calls. This allows the Cascade System to satisfy both central heating and domestic hot water calls at the same time. At the completion of a domestic hot water call, the CH/DHW Boilers will again be available to respond to central heating calls. Press the **LEFT** or **RIGHT** buttons to adjust the CH/DHW Boilers setting then press the **OK** button to store the setting.

NOTICE

Splitting the Cascade System into CH only and CH/DHW boilers requires the boilers to be piped as shown in Figure 11, page 32. The CH/DHW boilers must be piped to both CH and DHW loads directly for proper operation.

NOTICE

DHW Priority must be set to Enabled in DHW Settings of the Cascade Master for proper operation.

NOTICE

All CH/DHW Boilers will respond to a domestic hot water call. It is important that the domestic load is capable of transferring all of the heat generated to prevent excessive boiler cycling.

Automatic Rotation

Default: Enabled

Automatic Rotation allows the lead stage automatic rotation function to be disabled. Press the **UP** or **DOWN** buttons to select Enabled or Disabled then press the **OK** button to store the setting.

- **Enabled** – The lead boiler automatically rotates every time a call for heat is received when a Switch option is chosen in CH Demand or every 24 hours when a Constant option is chosen in CH Demand.
- **Disabled** – The lead boiler is always the Master boiler followed by each Slave boiler.

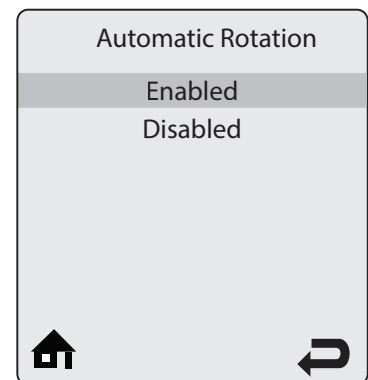
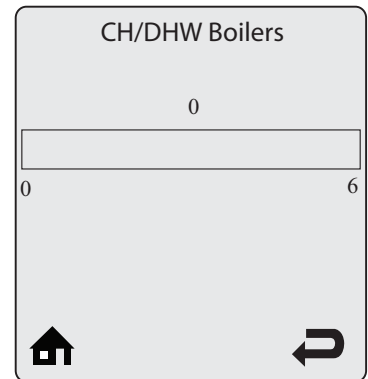

Cascade Settings

CH Proportional Gain

Default: 7

CH Proportional Gain allows the cascade response to be adjusted for a central heating call. CH Proportional Gain has the greatest influence when the system temperature is far away from the setpoint. Press the **LEFT** or **RIGHT** buttons to adjust the CH Proportional Gain then press the **OK** button to store the setting.

- **Increase CH Proportional Gain**

- The Cascade System will reach setpoint faster, but overshooting the setpoint may occur.
- To reach the setpoint faster, increase the CH Proportional Gain value by 2. Perform Cascade Autodetection and initiate a central heating call. Observe the cascade response and make further adjustments if necessary.

- **Decrease CH Proportional Gain**

- The Cascade System will take longer to reach the setpoint, but setpoint overshooting is minimized.
- If the setpoint is reached too quickly, decrease the CH Proportional Gain value by 2. Perform Cascade Autodetection and initiate a central heating call. Observe the cascade response and make further adjustments if necessary.

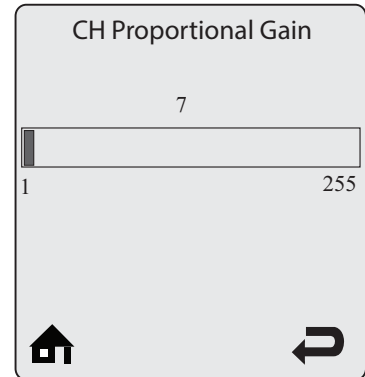

NOTICE

Only make adjustments to this setting after consulting ACV-Triangle Tube Technical Support. Improper adjustment of CH Proportional Gain could lead to temperature fluctuations and erratic cascade operation.

CH Integral Gain

Default: 245

CH Integral Gain allows the cascade response to be adjusted for a central heating call. CH Integral Gain has the greatest influence when the system temperature is close to the setpoint. Press the **LEFT** or **RIGHT** buttons to adjust the CH Integral Gain then press the **OK** button to store the setting.

- **Increase CH Integral Gain**

- The Cascade System will take longer to reach the setpoint, but setpoint overshooting is minimized.
- If the setpoint is reached too quickly, increase the CH Integral Gain value by 2. Perform Cascade Autodetection and initiate a central heating call. Observe the cascade response and make further adjustments if necessary.

- **Decrease CH Integral Gain**

- The Cascade System will reach setpoint faster, but overshooting the setpoint may occur.

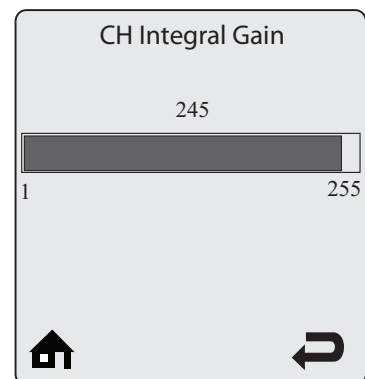

Cascade Settings

- To reach the setpoint faster, decrease the CH Integral Gain value by 2. Perform Cascade Autodetection and initiate a central heating call. Observe the cascade response and make further adjustments if necessary.

NOTICE

Only make adjustments to this setting after consulting ACV-Triangle Tube Technical Support. Improper adjustment of CH Integral Gain could lead to temperature fluctuations and erratic cascade operation.

DHW Proportional Gain

Default: 7

DHW Proportional Gain allows the cascade response to be adjusted for a domestic hot water call. DHW Proportional Gain has the greatest influence when the system temperature is far away from the setpoint. Press the **LEFT** or **RIGHT** buttons to adjust the DHW Proportional Gain then press the **OK** button to store the setting.

- **Increase DHW Proportional Gain**

- The Cascade System will reach setpoint faster, but overshooting the setpoint may occur.
- To reach the setpoint faster, increase the DHW Proportional Gain value by 2. Perform Cascade Autodetection and initiate a domestic hot water call. Observe the cascade response and make further adjustments if necessary.

- **Decrease DHW Proportional Gain**

- The Cascade System will take longer to reach the setpoint, but setpoint overshooting is minimized.
- If the setpoint is reached too quickly, decrease the DHW Proportional Gain value by 2. Perform Cascade Autodetection and initiate a domestic hot water call. Observe the cascade response and make further adjustments if necessary.

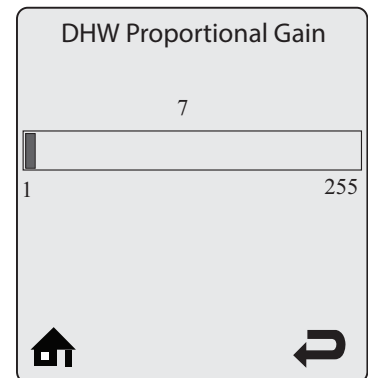

NOTICE

Only make adjustments to this setting after consulting ACV-Triangle Tube Technical Support. Improper adjustment of DHW Proportional Gain could lead to temperature fluctuations and erratic cascade operation.

Cascade Settings

DHW Integral Gain

Default: 245

DHW Integral Gain allows the cascade response to be adjusted for a domestic hot water call. DHW Integral Gain has the greatest influence when the system temperature is close to the setpoint. Press the **LEFT** or **RIGHT** buttons to adjust the DHW Integral Gain then press the **OK** button to store the setting.

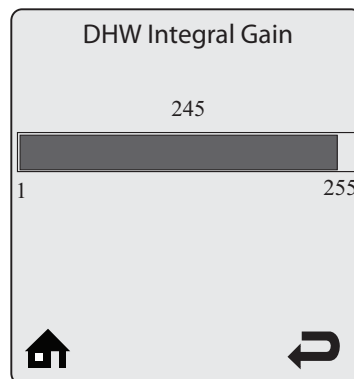

- **Increase DHW Integral Gain**

- The Cascade System will take longer to reach the setpoint, but setpoint overshooting is minimized.
- If the setpoint is reached too quickly, increase the DHW Integral Gain value by 2. Perform Cascade Autodetection and initiate a domestic hot water call. Observe the cascade response and make further adjustments if necessary.

- **Decrease DHW Integral Gain**

- The Cascade System will reach setpoint faster, but overshooting the setpoint may occur.
- To reach the setpoint faster, decrease the DHW Integral Gain value by 2. Perform Cascade Autodetection and initiate a domestic hot water call. Observe the cascade response and make further adjustments if necessary.

NOTICE

Only make adjustments to this setting after consulting ACV-Triangle Tube Technical Support. Improper adjustment of DHW Integral Gain could lead to temperature fluctuations and erratic cascade operation.

Modbus Interface

Modbus Interface

The Modbus Interface allows a Building Management System (BMS) to directly connect to the Prestige. A BMS can read information from the boiler to determine its operating state, lockout status, sensor readings, etc. A BMS can also operate the boiler by providing a setpoint.

Protocol	MODBUS RTU
Baud Rate	38400bps
Data Length	8
Parity	None
Stop Bits	1
Physical Layer	RS485 (2 wire)

DEC	HEX	Description
03	0x03	Read Holding Registers
04	0x04	Read Input Registers
06	0x06	Write Single Register
16	0x10	Write Multiple Registers
17	0x11	Report Slave ID

Address DEC (HEX)	Supported Commands	Description	Byte: Format	Notes
512 (0x0200)	0x03 0x06 0x10	CH Demand	MB:U8 LB:U8	<p>Writing 0= Modbus CH1 Demand has priority over a DHW call 255 = DHW call has priority over a Modbus CH1 Demand</p> <p>Reading 0 = No CH Calls Present 255 = CH1 or CH2 Call Present</p> <p>Writing 0 = End CH1 Demand 255= Begin CH1 Demand A CH1 Demand lasts for 30 seconds from the last successful write.</p>
513 (0x201)	0x03 0x06 0x10	Maximum Firing Rate	LB:U8	Value = Maximum Firing Rate % This register becomes active when 255 is written to register 512 (0x0200)
514 (0x202)	0x03 0x06 0x10	CH Setpoint	LB:U8	Value = CH Setpoint °C This register becomes active when 255 is written to register 512 (0x0200)
1280 (0x0500)	0x03	CH1 Maximum Setpoint	LB:U8	Value = °C
1281 (0x0501)	0x03	DHW Storage Setpoint	LB:U8	Value = °C

Modbus Interface

Table 9: Input Registers (Read Only)

Address DEC (HEX)	Supported Commands	Description	Byte: Format	Notes
0 (0x0000)	0x04	Boiler Status	LB: Flag8	Bit: Description 0: PC Manual Mode 1: DHW Mode 2: CH Mode 3: Freeze Protection Mode 4: Flame Present 5: CH(1) Pump 6: DHW Pump 7: System / CH2 Pump 0 = Off, 1 = On
1 (0x0001)	0x04	Lockout Status	MB: Flag8 LB:U8	Bit: Description 1: Lockout Code Type 0 = Automatic Reset Lockout 1 = Manual Reset Lockout Value = Lockout Code
2 (0x0002)	0x04	Lockout Status	LB:U8	0 = Single / Master Boiler 1 = Slave 1 2 = Slave 2 3 = Slave 3 4 = Slave 4 5 = Slave 5 F = Single / Master Display
768 (0x0300)	0x04	Boiler Supply Temperature / System Temperature	S16	Value = 0.1°C Invalid Value = 32768 (0x8000) Value is the Boiler Supply Temperature unless the System Temperature Sensor is installed
769 (0x0301)	0x04	Boiler Return Temperature	LB:S8	Value = °C Invalid Value = 65472 (0xFFC0)
770 (0x0302)	0x04	DHW Storage Temperature	LB:S8	Value = °C Invalid Value = 32768 (0x8000)
771 (0x0303)	0x04	Boiler Flue Temperature	LB:S8	Value = °C Invalid Value = 65472 (0xFFC0)
772 (0x0304)	0x04	Outdoor Temperature	LB:S8	Value = °C Invalid Value = 32768 (0x8000)
773 (0x0305)	0x04	Future Use	LB:U8	
774 (0x0306)	0x04	Flame Ionization Current	LB:U8	Value = Flame Current µA
775 (0x0307)	0x04	Boiler / Cascade Firing Rate	LB:U8	Value = Firing Rate %
776 (0x0308)	0x04	Boiler Setpoint	LB:U8	Value = °C Invalid Value = 32768 (0x8000)

Manual Operation

Manual Operation



Navigation: Home Screen>Installer Menu>Manual Operation

The Manual Operation Screen allows the burner and circulators to be manually enabled for testing.

Fan

Press the **OK** button while the FAN icon is highlighted to manually fire the burner and power the CH (1) circulator. Press the **LEFT** and **RIGHT** buttons to adjust the firing rate from 1 % (Low Fire) to 100% (High Fire). Hold down the **LEFT** or **RIGHT** buttons to rapidly increase or decrease the firing rate. Press the **OK** button again while the FAN icon is highlighted to shutdown the burner when finished.

NOTICE

An adequate CH load must be present to dissipate the heat generated while the burner is manually fired. If an adequate CH load is not available, an indirect water heater can be used to dissipate the heat by creating a domestic hot water call which will enable the DHW circulator.

CH CH1

Press the **OK** button while the CH CH1 icon is highlighted to manually power the CH (1) circulator. Press the **OK** button again while the CH CH1 icon is highlighted to shutdown the CH (1) circulator.

NOTICE

The Auxiliary Boiler circulator is also powered when the CH (1) circulator is manually enabled.

DHW

Press the **OK** button while the DHW icon is highlighted to manually power the DHW circulator. Press the **OK** button again while the DHW icon is highlighted to shutdown the DHW circulator.

NOTICE

The Auxiliary Boiler circulator is also powered when the DHW circulator is manually enabled.

SYS CH2

Press the **OK** button while the SYS CH2 icon is highlighted to manually power the System circulator. Press the **OK** button again while the SYS CH2 icon is highlighted to shutdown the System circulator.

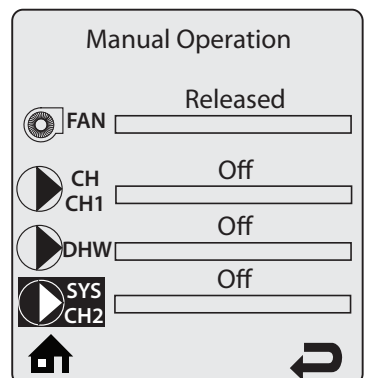
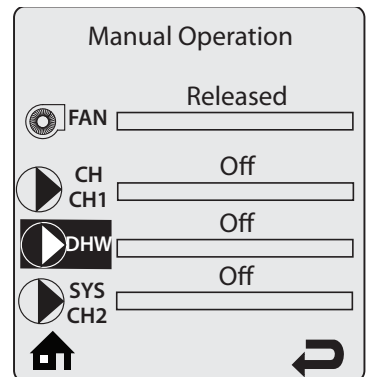
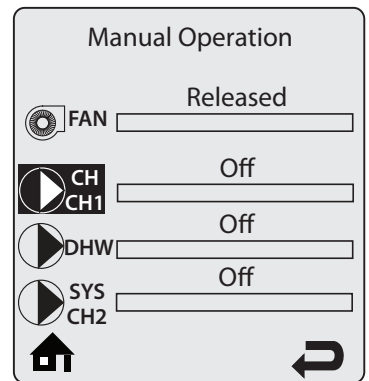
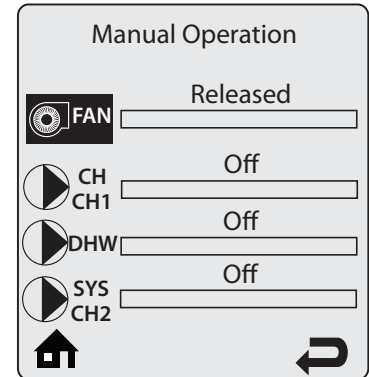

Additional quality water heating equipment available from ACV- Triangle Tube

MAXI-FLO AND SPA HEAT EXCHANGERS



- Construction of high quality corrosion resistant stainless steel (AISI 316) or titanium
- Specially designed built-in flow restrictor to assure maximum heat exchange
- Compact and light weight
- Available in 8 sizes that can accommodate any size pool or spa

SMART INDIRECT FIRED WATER HEATERS



- Exclusive tank-in-tank design
- Stainless steel construction
- Available in 7 sizes
- Limited LIFETIME residential warranty
- 6 year Limited commercial warranty
- Self cleaning/self descaling design

TTP BRAZED PLATE HEAT EXCHANGERS

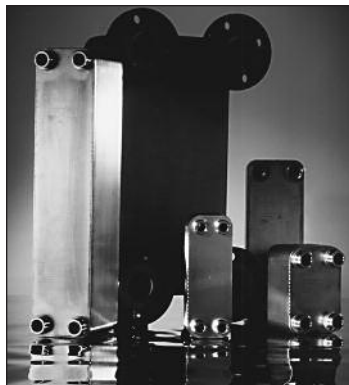

- For domestic water, snow melting, radiant floor, refrigeration
- Plates made of stainless steel, with a 99.9 % copper and brazed, ensuring a high resistance to corrosion
- Self cleaning and self descaling
- Computerized sizing available from ACV- Triangle Tube
- Available in capacities from 25,000 BTU/hr to 5,000,000 BTU/hr



Triangle Tube - 1 Triangle Lane - Blackwood, NJ 08012 - Tel: (856) 228 8881 - Fax: (856) 228 3584
E-mail: sales@triangletube.com