

VARMAX TWIN SERIES BOILERS

**Gas condensing boiler
with modulating burner**

INSTALLATION, COMMISSIONING AND SERVICING INSTRUCTIONS

Models: 550 kW, 640 kW, 780 kW and 900 kW

*NATURAL GAS
PROPANE GAS*

IMPORTANT NOTE

**THESE INSTRUCTIONS MUST BE READ
AND UNDERSTOOD BEFORE INSTALLING,
COMMISSIONING, OPERATING OR
SERVICING EQUIPMENT**

CONTENTS

1. WARNINGS AND RECOMMENDATIONS	4
1.1. VARMAX TWIN supply limits.....	4
1.2. Transport and storage.....	4
1.3. Symbols used in this document.....	4
1.4. Qualification of personnel for installation, adjustment, use and maintenance.....	5
1.5. Safety instructions.....	5
1.6. Water characteristics.....	5
2. APPROVALS	6
2.1. Compliance with European Directives.....	6
2.2. Regulatory installation conditions.....	6
2.3. Environmental compatibility.....	6
2.4. Gas category.....	6
2.5. Gas supply pressures.....	7
3. TECHNICAL SPECIFICATIONS	8
3.1. Dimensions.....	8
3.2. Doorway.....	9
3.3. Combustion at 15°C and 1013 mbar.....	9
3.4. Operating conditions.....	11
3.5. Electrical connection.....	11
4. INSTALLATION	12
4.1. Positioning the air filters and the filtering layers.....	12
4.2. Installing the boiler.....	12
4.3. Installing the LPB bus cable trays.....	14
4.4. Opening / closing the casing doors.....	15
4.5. Removing the control panels (MMI).....	15
4.6. Installing / removing the casing doors.....	15
4.7. Installing / removing the side panels.....	15
4.8. Installing / removing the upper panels.....	15
4.9. Step.....	15
4.10.Changing the gas type (G20 to G31).....	15
4.11.Exhaust connection.....	16
4.12.Hydraulic connection.....	20
4.13.Gas connection.....	23
4.14.Electrical connection.....	23
5. START-UP (COMMISSIONING)	25
6. CHECKS AFTER COMMISSIONING	25
7. MAINTENANCE OPERATIONS	25
8. HYDRAULIC DIAGRAMS AND CONFIGURATIONS	26
9. SPARE PARTS LIST	56

1. WARNINGS AND RECOMMENDATIONS

PLEASE READ THIS MANUAL CAREFULLY BEFORE INSTALLING, MAINTAINING AND USING THE BOILER. IT CONTAINS IMPORTANT SAFETY INFORMATION.

1.1. VARMAX TWIN supply limits

The VARMAX TWIN boiler you have received is composed of:

- 2 VARMAX type generators with the same power to be connected to each other
- 1 450 mm common exhaust flue between the generators
- 4 Teflon plates (to help position the generators)
- 2 LPB bus cable trays with holding screws
- 1 LPB bus cable
- 2 OCI 345 communication modules with holding screws
- 1 QAZ 36 flow sensor



INFORMATION:

The hydraulic connection elements to be added according to the diagram are not supplied (refer to chapters 4.12 and 8).

This manual describes the specific features of the assembly. Everything which relates to one of the 2 generators (internal accessibility, settings, maintenance, spare parts, etc.) is described in the particular generator's manual. The following data must therefore be used:

- For the VARMAX TWIN 550, see the information for the VARMAX 275,
- For the VARMAX TWIN 640, see the information for the VARMAX 320,
- For the VARMAX TWIN 780, see the information for the VARMAX 390,
- For the VARMAX TWIN 900, see the information for the VARMAX 450.

1.2. Transport and storage

The generators:

- must be arranged horizontally in a place where the temperature is between 0 °C and +50 °C and whose relative humidity is between 5% and 95%.
- must not be stacked,
- must be protected from humidity.

1.3. Symbols used in this document



INFORMATION:

This symbol draws attention to comments.



IMPORTANT:

Failure to comply with these instructions may cause damage to the installation or to other objects.

**WARNING:**

Failure to comply with these instructions may cause injury and serious material damage.

**WARNING:**

Failure to comply with these instructions may cause electrocution.

1.4. Qualification of personnel for installation, adjustment, use and maintenance

The operations to install, adjust and maintain the boiler must be carried out by qualified and approved professionals in accordance with current local and national regulations. These operations may require intervention under voltage, with the casing doors (located on the front of the generators) open. The basic usage operations must be carried out with the casing doors closed.

1.5. Safety instructions

- Always remove the power supply to the boiler and shut off the overall gas supply to it before carrying out any work on it.
- Check that there are no gas leaks on the installation after any intervention on the boiler (maintenance or repair).

**WARNING:****If you smell gas:**

- Do not use any naked flames, smoke or activate any contacts or electric switches.
- Switch off the gas supply.
- Ventilate the premises.
- Look for the leak and correct it.

**WARNING:****If any smoke is released:**

- Switch off the generators.
- Ventilate the premises.
- Look for the leak and correct it.

**WARNING:**

This boiler's earth continuity is provided by link cables (green/yellow) and specific holding screws. During any disassembly operations, make sure that the cables in question are reconnected; you **MUST** also reuse the original holding screws.

1.6. Water characteristics

Refer to the VARMAX generator's installation, use and maintenance manual.

2. APPROVALS

2.1. Compliance with European Directives

- Low voltage (2006/95/CE)

This appliance is not intended for use by persons (including children) whose physical, sensory or mental abilities are reduced, or persons without experience or knowledge, unless they have been able to

benefit, through someone responsible for their safety, from supervision or prior instruction concerning the use of the appliance.

Children must be supervised to ensure they do not play with the appliance.

- Electromagnetic compatibility (2004/108/CEE)

- Efficiency (92/42/CEE)

- Gas appliances (2009/142/CE)

- WEEE (2012/19/UE)

Waste Electrical and Electronic Equipment.

2.2. Regulatory installation conditions

The appliance must be installed and maintained by a qualified professional, in accordance with the regulations and current regulatory practices in the country where the boiler is installed.

2.3. Environmental compatibility



This appliance contains electrical and electronic elements which must not be thrown away with household waste.

Local legislation must be complied with.

2.4. Gas category

This boiler has been adjusted in the factory to work with **group H (type G20) natural gas with a supply pressure of 20 mbar.**



INFORMATION: Any work on a sealed component will lead to loss of the guarantee.

	Category GB, IE
VARMAX TWIN 550 and 640	II _{2H3P}
VARMAX TWIN 780 and 900	I _{2H}

2.5. Gas supply pressures

**INFORMATION:**

The pressures provided below must be taken at the input to the gas valve (20 mbar).

	Natural gas H G20 20 mbar	G31 Propane gas (for VARMAX TWIN 550 and 640)
Nominal pressure (mbar)	20	37
Minimum pressure (mbar)	17	25
Maximum pressure (mbar)	25	45

3. TECHNICAL SPECIFICATIONS

3.1. Dimensions

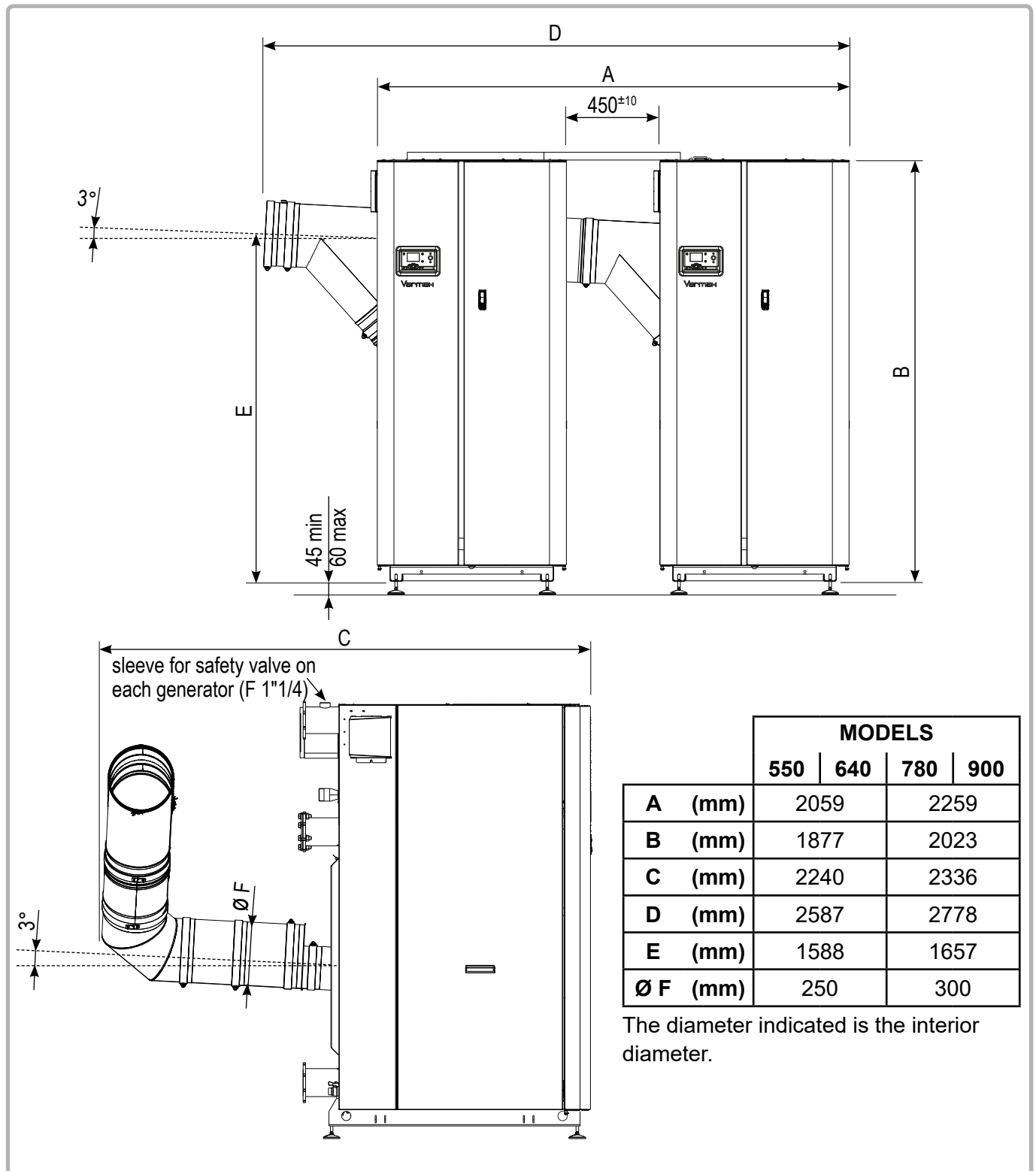

figure 1 - Dimensional characteristics



IMPORTANT:

The dimension of 450 mm between the 2 generators must be respected to assemble the exhaust flue (it is not a minimum or maximum dimension).

3.2. Doorway

Refer to the VARMAX generator's installation, use and maintenance manual.

3.3. Combustion at 15°C and 1013 mbar

		MODELS			
		550	640	780	900
Nominal power Pn (80/60°C)	kW	536	624	762	878
Nominal power when condensing Pn (50/30°C)	kW	580	676	830	956
Rated heat input Qn	kW	550	640	780	900
Min heat input Qmin	kW	66	66	87	87
Gas flow rate at Pn (15 °C) *	m ³ /h	58.2	67.72	82.6	95.2
CO ₂ value range	%	at Qmin: 8.3 % < CO ₂ < 8.7 % at Qmax: 8.8 % < CO ₂ < 9.2 %			
Exhaust mass flow rate at Qn / Qmin (80/60°C) *	g/s	240.1 / 31	257.7 / 30.9	352 / 43	398 / 44
Exhaust mass flow rate at Qn / Qmin (50/30°C) *	g/s	225.9 / 26	239.5 / 26.6	327 / 41	378 / 42
Exhaust temperature at Qn / Qmin (80/60°C) *	°C	61 / 54.7	60.8 / 55.1	60.3 / 54.5	62.1 / 55.6
Exhaust temperature at Qn / Qmin (50/30°C) *	°C	35.4 / 30.7	37.1 / 31	36 / 29.3	36 / 30.4
Firebox pressure at nominal Qcal (B23)	Pa	132	162	152	203
Exhaust outlet interior diameter	mm	250	250	300	300
Maximum allowable nozzle pressure (B23P) at Qn / Qmin (80/60°C)*	Pa	127 / 3	151 / 3	177 / 3	200 / 3
Maximum allowable nozzle pressure (B23P) at Qn / Qmin (50/30°C)*	Pa	104 / 3	123 / 3	149 / 3	178 / 3
Combustion air flow rate at Qn * (15°C)	m ³ /h	704.8	820.2	999.6	1153.4
NOx class		6			
Smoke removal and air inlet type classifications		B23, B23P			

* values corresponding to a G20 setting.

3.3.1. G31 Propane Gas (for relevant models and destination countries)

		MODELS	
		550	640
Nominal power P _n (80/60°C)	kW	536	624
Nominal power when condensing P (50/30°C)	kW	580	676
Nominal heat input Q _n	kW	550	640
Minimum heat input Q _{min}	kW	90	90
Gas flow rate at P _n	m ³ /h	22.5	26.2
CO ₂ value ranges	%	at Q _{min} : 9.8 % < CO ₂ < 10.2 % at Q _{max} : 10.4 % < CO ₂ < 10.8 %	
Flue-gas mass flow rate at Q _n / Q _{min} (80/60°C)	g/s	244 / 42	284 / 42
Flue-gas mass flow rate at Q _n / Q _{min} (50/30°C)	g/s	234 / 39	272 / 40
Flue-gas temperature at Q _n / Q _{min} (80/60°C)	°C	63 / 58	65.4 / 58.4
Flue-gas temperature at Q _n / Q _{min} (50/30°C)	°C	40 / 29	41.4 / 31.3
Appliance pressure at nominal Q _{cal} (B23)	Pa	123	165
Inside diameter of flue-gas output	mm	250	250
Maximum allowable nozzle pressure (B23P) at Q _n / Q _{min} (80/60°C)	Pa	93 / 11	132 / 11
Maximum allowable nozzle pressure (B23P) at Q _n / Q _{min} (50/30°C)	Pa	84 / 16	118 / 13
Combustion air flow rate at Q _n	m ³ /h	705	820
NO _x class		6	
Flue-gas removal and air inlet type classifications		B23, B23P	

3.4. Operating conditions

		MODELS			
		550	640	780	900
Max flow temperature setting	°C	85			
Max flow temperature	°C	88			
Maximum safe temperature	°C	110			
Max service pressure	hPa (bar)	6000 (6)			
Min cold pressure	hPa (bar)	1000 (1)			
Hydraulic pressure loss at ΔT 20 per generator 2 or 3 tapping version 4 tapping version Main exchanger Condenser	daPa				
		820	1185	770	970
		790 50	1060 65	660 190	840 230
Nominal water flow rate (P/20) VARMAX TWIN	m ³ /h	23	26.8	32.8	37.8
Nominal water flow rate (P/20) per generator	m ³ /h	11.5	13.4	16.4	18.9
Maximum water flow rate (P/10) per generator	m ³ /h	23.0	26.8	32.8	37.8
Total water content (2 generators)	L	478	478	574	574
Total weight without water (2 generators)	kg	1050	1050	1240	1240
Installation premises temperature (min / max)	°C	5 / 45			
Installation premises relative humidity		between 5% and 95%			
Protection level		IP20			
Maximum installation altitude	m	2000			

3.5. Electrical connection

		MODELS			
		550	640	780	900
Electrical supply	V	230 V AC (+10% -15%), 50Hz			
Electrical power consumed at Qn (excluding accessory) VARMAX TWIN	W	476	704	960	1320
Electrical power consumed in standby mode VARMAX TWIN	W	10			
Maximum length of sensor cables	m	DHW sensor: 10 Outdoor sensor: 40 in 0.5 mm ² (120 in 1.5 mm ²) Ambient thermostat: 200 in 1.5 mm ² Room thermostat: 200 in 1.5 mm ²			
Power terminal output per generator	V	230V AC (+10%, -15%)			
	A	5 mA at 1A			

4. INSTALLATION

4.1. Positioning the air filters and the filtering layers



IMPORTANT: The air filters provided with the generators **MUST** be installed.

The air filters must be installed before the gas lines are connected. Refer to the VARMAX generator's installation, usage and maintenance manual, paragraph "4-1 Positioning the air filter and the layer").

4.2. Installing the boiler

The VARMAX TWIN boilers must not be installed on a flammable surface (wooden floor, plastic floor covering, etc.).

Recommended distances relative to walls and ceiling:

Sufficient clearances must be provided to permit easy maintenance operations on the boilers.

The **minimum** values (in mm) are indicated in figure 2 and in the table below.

	A*	B*	C	H
MODELS	550	450	600	263
	640	450	600	263
	780	450	700	427
	900	450	700	427

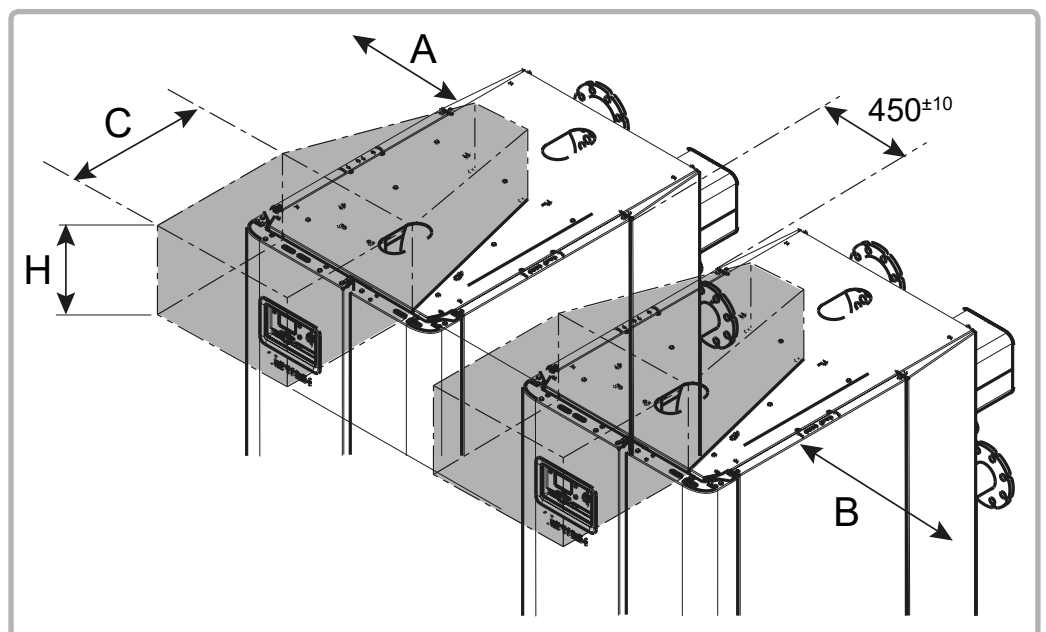

figure 2 - Peripheral clearance

The greyed out zone above the boiler must remain free of any obstacles to enable the burner to be inspected and cleaned.

These values cannot be substituted for the specific regulatory requirements.



IMPORTANT:

- The 2 VARMAX generators must be positioned horizontally using a spirit level to enable effective gas release for the exchanger body (use the base as the reference surface).
- The space between the 2 VARMAX generators must be $450^{\pm 10}$ mm.
- A 2 cm free space must also be left above the side panels to allow for their disassembly and reassembly.
- The 2 generators must be in the same alignment and on the same horizontal level.

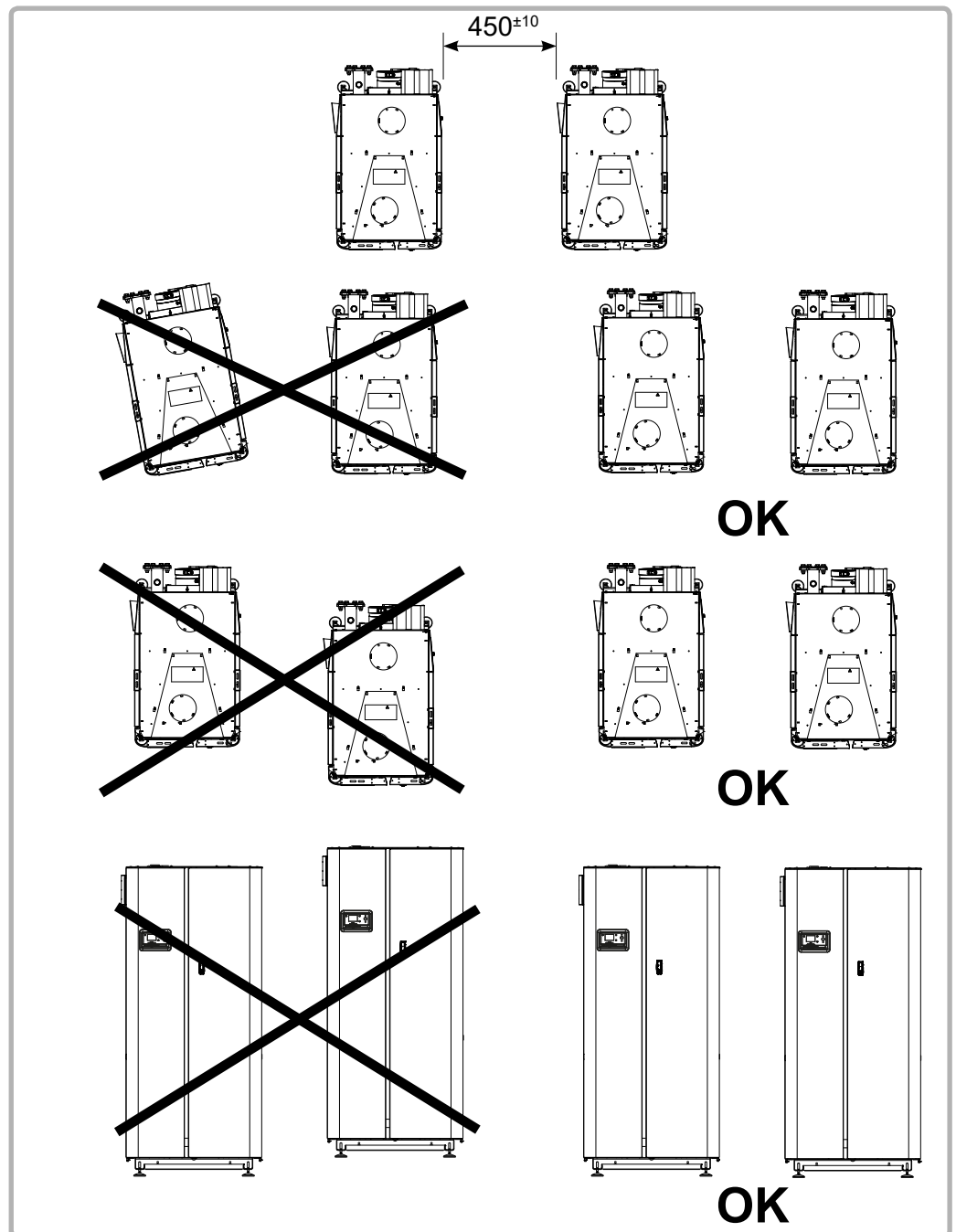

figure 3 - Generator positioning

To adjust the flush level, screw or unscrew the 4 adjustable feet, using a 17 mm wrench.

4 Teflon plates are provided to facilitate the introduction of the 2 generators in relation to each other:

- Put one plate under each of the 4 feet of the generator to be moved,

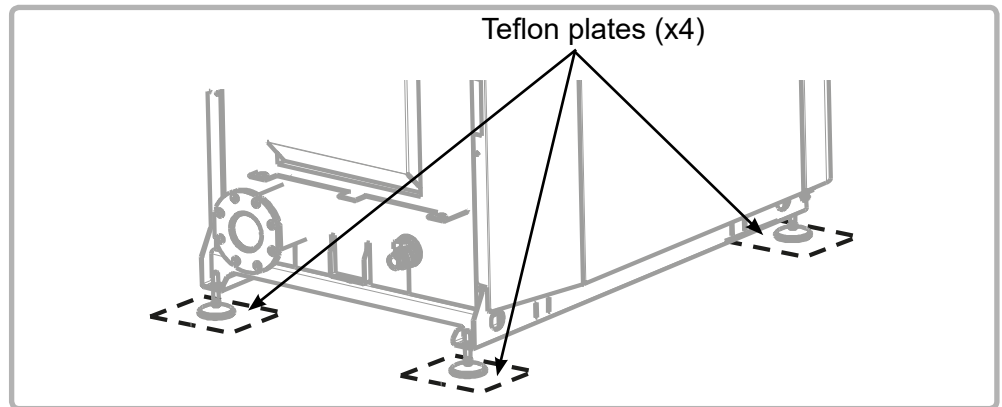

figure 4 - Teflon plate positioning

- Position the generator,
- Remove the Teflon plates.

4.3. Installing the LPB bus cable trays

Position the 2 trays for the LPB bus cable on the rear of the 2 generators and secure them using the 4 self-tapping screws provided.

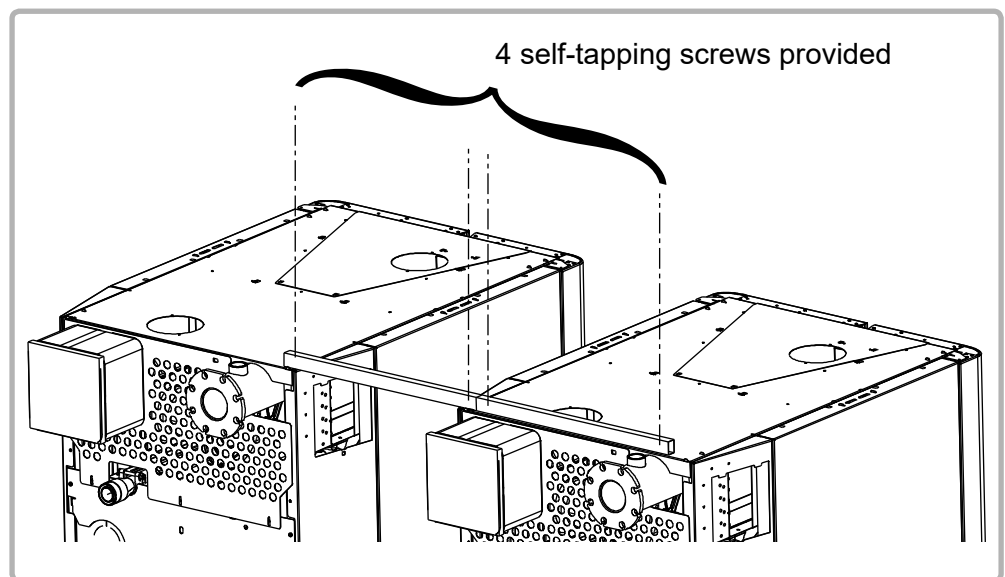

figure 5 - cable trays

The roof of each generator must be drilled (\varnothing 4 bit); to do so, use the trays as scale.

4.4. Opening / closing the casing doors

Refer to the VARMAX generator's installation, use and maintenance manual.

4.5. Removing the control panels (MMI)

Refer to the VARMAX generator's installation, use and maintenance manual.

4.6. Installing / removing the casing doors

Refer to the VARMAX generator's installation, use and maintenance manual.

4.7. Installing / removing the side panels

Refer to the VARMAX generator's installation, use and maintenance manual.

4.8. Installing / removing the upper panels

Refer to the VARMAX generator's installation, use and maintenance manual.

4.9. Step

Refer to the VARMAX generator's installation, use and maintenance manual.

4.10. Changing the gas type (G20 to G31)



WARNING:

Changing the type of gas used must be performed on the two VARMAX generators.



WARNING:

The use of Propane gas is forbidden on the 780 and 900 VARMAX TWIN models.

Refer to the VARMAX generator's installation, use and maintenance manual.

4.11. Exhaust connection



IMPORTANT:

There is a specific connection for the exhausts to the VARMAX TWIN boilers. Do not refer to the VARMAX generator's installation, use and maintenance manual.

The size of the chimney pipes must be determined taking account of combustion gas pressure on boiler output equal to 0 Pa (see table § 3.3). You must comply with the regulatory texts and rules of the art that apply in the country where the boiler will be installed, i.e.:

One exhaust temperature sensor per generator guarantees the protection of the combustion product evacuation ducts.

The VARMAX TWIN boilers are approved to be connected to:

- a B23 chimney (all models)
- a B23P chimney (all models)



INFORMATION:

The duct lengths provided below are in linear metres (ml). The total length of all the ducts is rounded to a straight-line length (the curves have a straight-line equivalent).

4.11.2. Installing the exhaust flue

The flue provided may be installed either to the right or the left of the VARMAX TWIN boiler.

Example with exhaust outlet to the left:

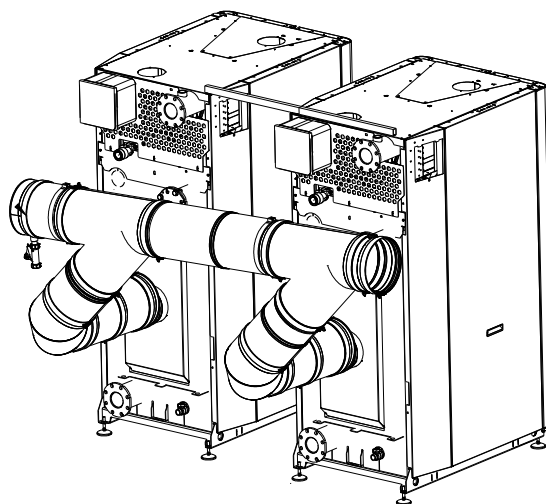

figure 6 - Flue orientation



INFORMATION:

When assembling the flue, we recommend fitting the assembly on the ground then installing it on the 2 generators. At least 3 people are required to handle and secure the assembly.

ITEM	MODELS		DESCRIPTIONS	QTY
	550 - 640 kW	780 - 900 kW		
1	AC-250-180	AC-300-200	Offset increase	2
2	ED 250-250 CD	ED 250-300 CD	Straight element length 250	4
3	EC 90-250 CD	EC 90-300 CD	90° curved element	2
4	ER 26/40 250 CD	ER 26/40 300 CD	Adjustable element length 260-400	2
5	T 135-250 CD	T 135-300 CD	T 135°	2
6	EPMF 250	EPMF 300	Measurement element	1
7	ER 55/90 250	ER 55/90 300	Adjustable element length 550-900	1
8	CEPL 250 CD	CEPL 300 CD	Side drain buffer	1
9	SIPHON 1"	SIPHON 1"	Siphon	1
10	JOINT-CD-250	JOINT-CD-300	Seal	19
11	--	--	Tube of grease for seals	1

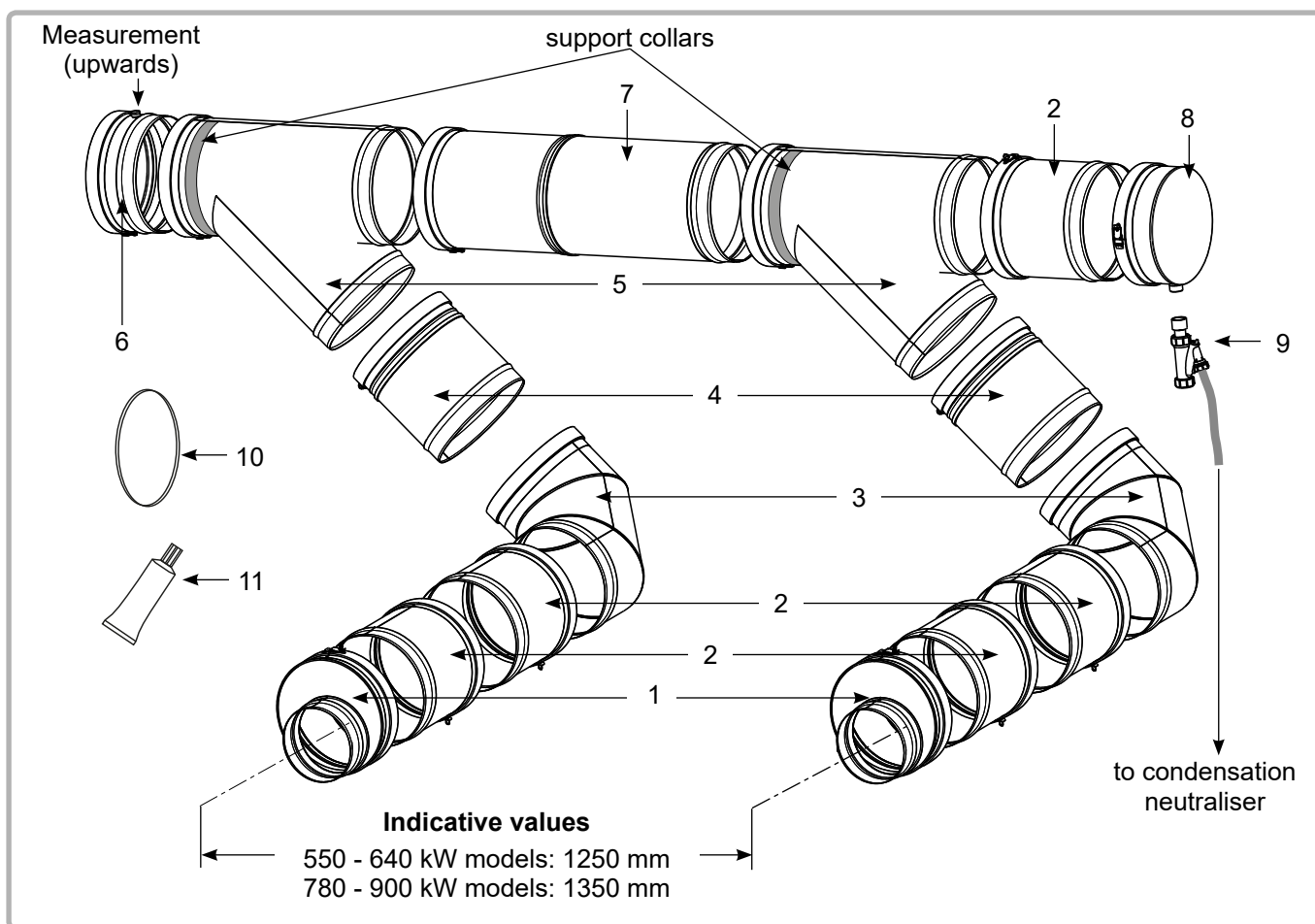

figure 7 - Flue assembly



IMPORTANT:

The 2 collars delivered with the smoke works kit may be used to support the assembly either on the ceiling or on the ground (their position is "greyed out" on each T at 135° - figure 7).



IMPORTANT:

During final connection to the generator exhaust outlet nozzles, make sure that there are not too many mechanical demands on the 2 offset increases (item 1) as this may create seal losses for the exhaust.

4.11.3. Connection to a B23 chimney

B23 type connection:

Air from the installation premises, gas evacuation through the roof via a natural draft pipe.



IMPORTANT:

Check that the boiler installation premises have high and low ventilation, that it conforms to current regulations and that it is not obstructed.

The size of the chimney pipes must be determined taking account of combustion gas pressure on boiler output equal to 0 Pa (see table § 3.3).

The exhaust extraction ducts must be made in a material resistant to the condensate that can form when the boiler is operating. These materials must also be able to withstand exhaust temperatures up to 120°C. Horizontal pipes must be avoided to limit condensation build-up.

Check that the combustion gas is evacuated via a sealed connection.

VARMAX TWIN boilers are high performance boilers with very low exhaust temperatures; consequently to retain a favourable draft the ducts must run upwards from the boiler outlet.



WARNING:

Check:

1. That the flue is not under pressure, with both generators operating.
2. If one of the generators is operating at minimum power, that the other generator does not discharge into it.

Dimensioning recommendations based on a POUJOLAT type (Condensor type) supply:

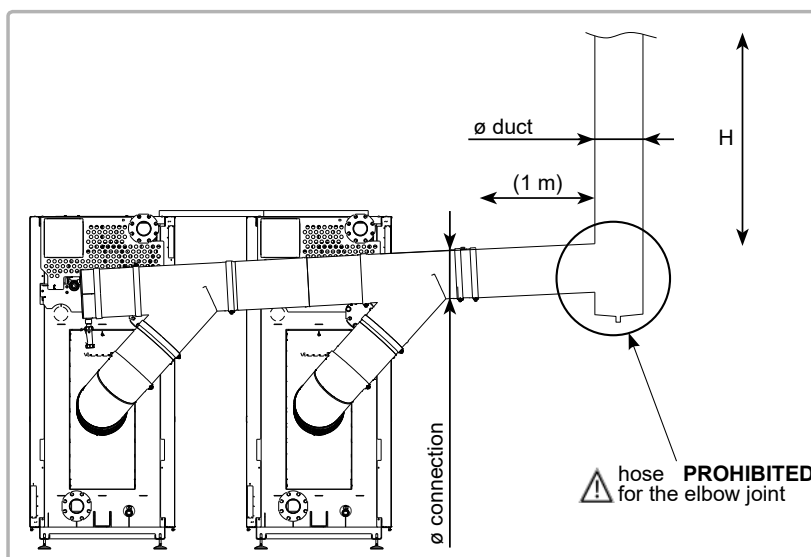

figure 8 - Sizing recommendations

Exhaust duct height in linear metres (ml)
(in 50/30°C operating regime)

Ø connection Ø duct Gas type	250 mm				300 mm				
	300 mm		350 mm		350 mm		400 mm		
	G20	G31	G20	G31	G20	G31	G20	G31	
MODELS	550	15 to 50	16 to 50	3 to 50	3 to 50	--	--	--	--
	640	16 to 50	--	3 to 50	5 to 50	--	--	--	--
	780	--	--	--	--	15 to 50	--	5 to 50	--
	900	--	--	--	--	33 to 50	--	6 to 50	--

WARNING:

The values below are provided for information purposes. They must be checked by calculation.

WARNING:

The VARMAX TWIN flue must not be made to support the exhaust duct's weight.

4.11.4. Connection to a B23P chimney

B23P type connection:

Air from the installation premises, gas evacuation through the roof via a pressurised duct.

IMPORTANT:

Check that the boiler installation premises have high and low ventilation, that it conforms to current regulations and that it is not obstructed.

WARNING:

For B23P type connection, it is VITAL to use ducts with CONDENSOR (Poujoulat) type CSTB notice (pressurised ducts).

WARNING:

The combustion product extraction duct must be dimensioned by using the parameters set out in the table in chapter 3.3. Depending on the actual configuration of the duct, a calculation is required to check that the pressures at the boiler outlet do not exceed the maximum allowable values (200 Pa). Values corresponding to the 50/30°C regime are to be used for this calculation.

Dimensioning recommendations based on a POUJOLAT (Condensor type) supply: See the figure on the previous page.

Exhaust duct height in linear metres (ml)
(in 50/30°C operating regime)

	Ø connection Ø duct Gas type	250 mm 250 mm		300 mm 300 mm	
		G20	G31	G20	G31
		MODELS	550	1 to 100	1 to 100
640	1 to 100		1 to 100	--	--
780	--		--	1 to 100	--
900	--		--	1 to 100	--



WARNING:

The values below are provided for information purposes. They must be checked by calculation.



WARNING:

The VARMAX TWIN flue must not be made to support the exhaust duct's weight.

4.12. Hydraulic connection

A water circulation pump integrated into each generator and a smart regulation logic enable optimum operation up to $P_{inst}/30$ (P_{inst} = Instant output power expressed as Th/h - $1Th/h = 1.163$ kW).

Below this rate of $P_{inst}/30$, the generators will continue to operate, but will gradually reduce their power (shutdown below $P_{inst}/46$).

In the main exchanger, as in the condenser on each generator, you must ensure that the rates recommended in paragraph 3.4 are not exceeded (i.e. Output power in nominal Th/h generator / 10).

Therefore, a differential pressure valve must be integrated into the circuit according to the diagram.

Sizing the pipes connecting the boiler to the installation must be done carefully, to minimise the pressure losses and so avoid oversized circulating pumps.

In some cases the diameter of the connection pipes will be greater than the diameter of the boiler tapings. The diameter increase can then be made advantageously after the union connectors, the stop valves, and/or the hydraulic balancing valves.

Tichelmann assembly encourages a natural balance of the flow rate between the 2 generators.

The VARMAX TWIN boilers are equipped with the following elements:

- A drainage valve on each generator's main exchanger,
- A drainage valve on each generator's condenser.

In accordance with the diagram, it is imperative to fit the boiler and its installation with the following components:

- powered isolating valve (with an end of run contact*) on the flow tapping on each generator's main exchanger,
- balancing / isolating valve on each generator's return tapping,
- anti-return flap,
- filters,
- mud cup,
- expansion vessel,
- effective drain mechanism,
- safety valve set at 6 bars, **on each generator**, sized according to each generator's heat output (see location figure 1 page 8).
- disconnecter on the boiler's filling circuit in relation to the supply network.

(*) The end of run contact only allows the generator to start up when full opening is reached.

The VARMAX TWIN are delivered either in 2/3 tapping connection version or in 4 tapping connection version. A 2/3 tapping version cannot be converted into a 4 tapping version and vice versa.

4.12.1. Hydraulic connection using 2 tappings

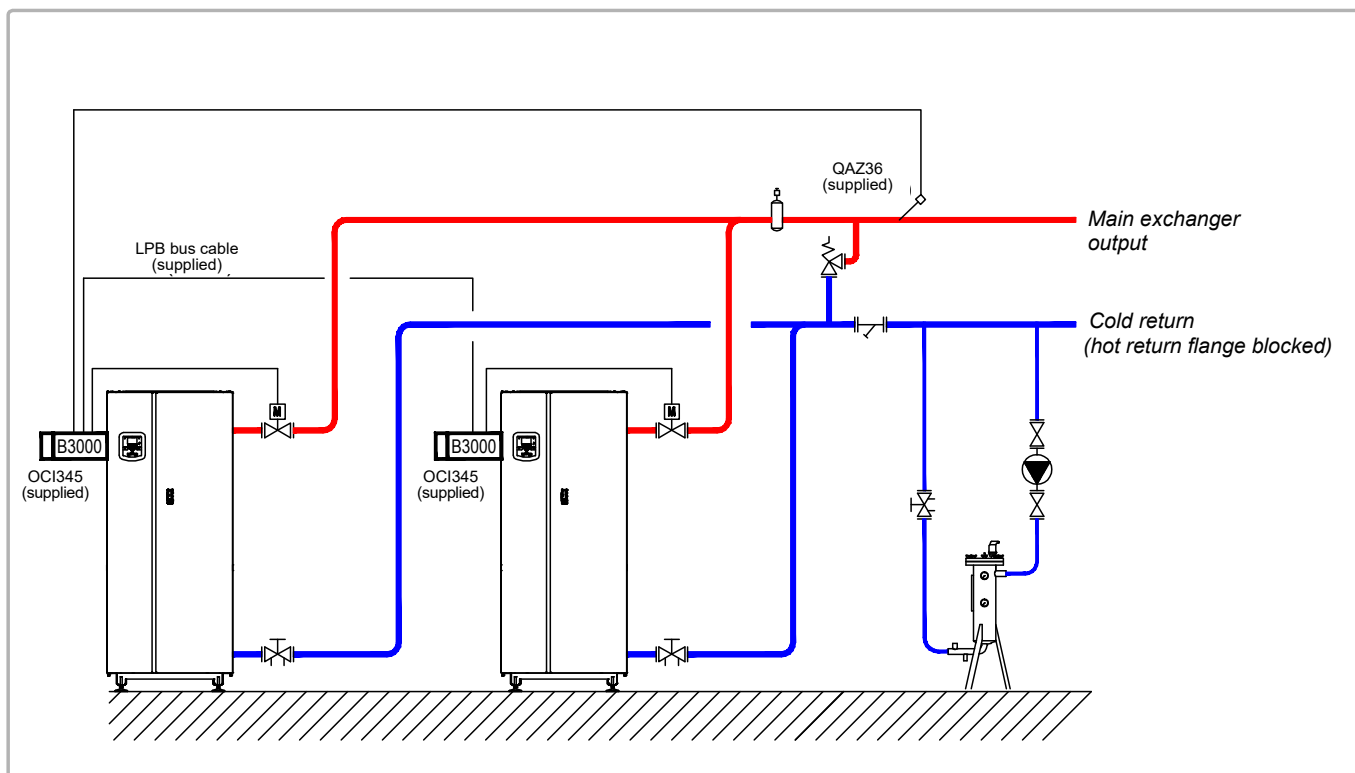

figure 9 - Hydraulic connection using 2 tappings

4.12.2. Hydraulic connection using 3 tappings

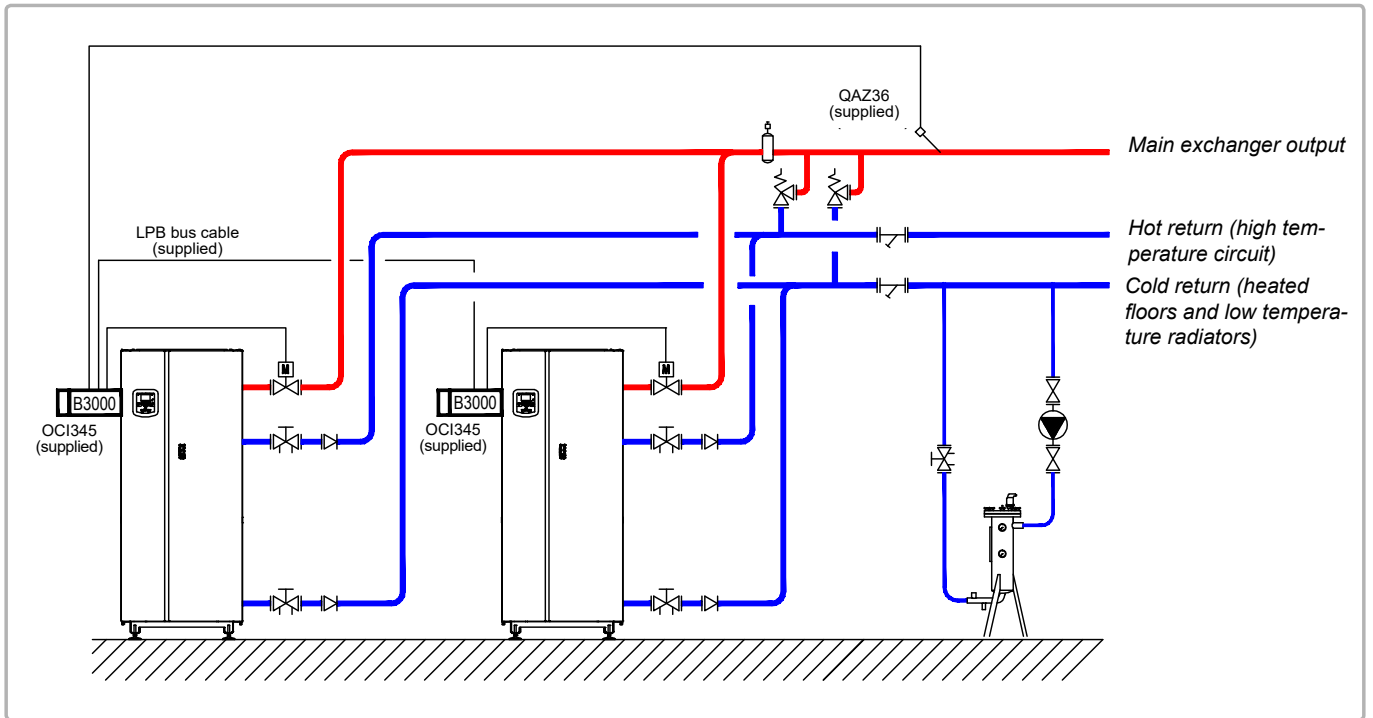

figure 10 - Hydraulic connection using 3 tappings

4.12.3. Hydraulic connection using 4 tappings

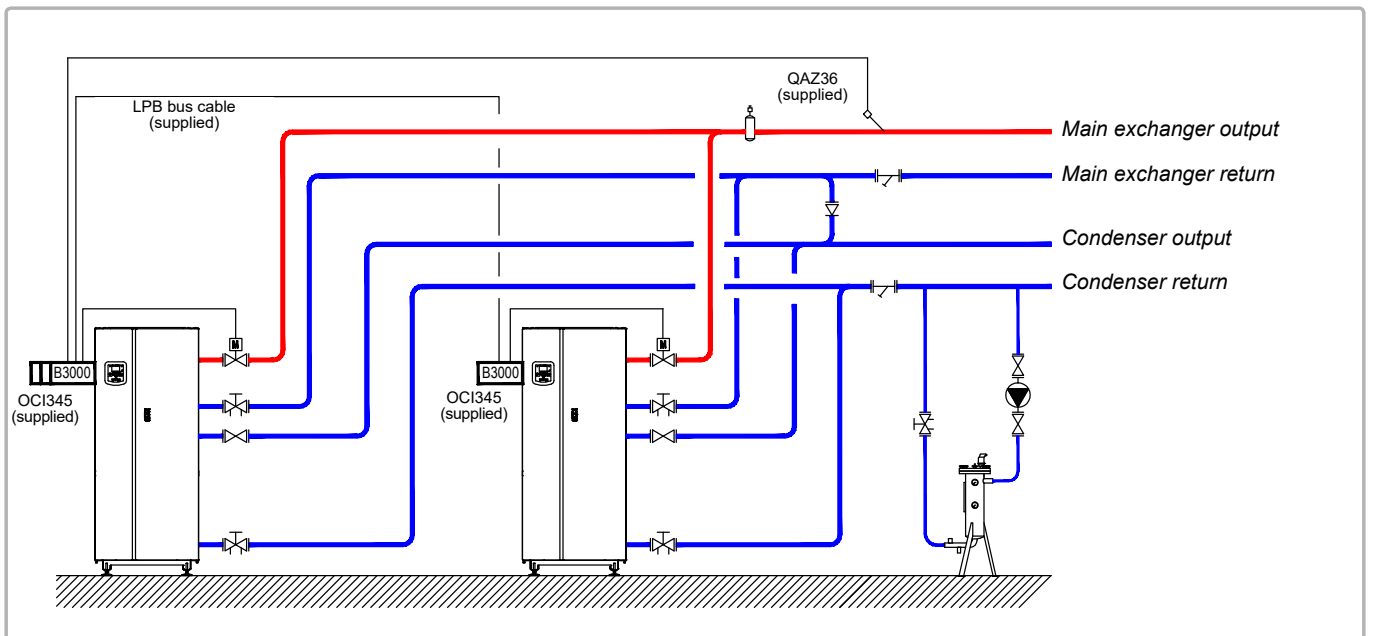

figure 11 - Hydraulic connection using 4 tappings

4.13. Gas connection



IMPORTANT:

- The gas must be connected on the 2 VARMAX generators
- The use of Propane is prohibited on the VARMAX TWIN 780 and 900 boilers.

Refer to the VARMAX generator's installation, use and maintenance manual.

4.14. Electrical connection



WARNING:

Ensure that the general electrical power supply has been cut off before starting any repair work.



WARNING:

You must respect the live (L) - neutral (N) polarity during electrical connection.



IMPORTANT:

The VARMAX generators must be connected to the earth and the national standards concerning low voltage electric installations in the country must be respected.

Provide a two pole circuit breaker upstream of EACH VARMAX GENERATOR (distance between contacts: 3.5 mm minimum). Fitting the electrical installation with a 30 mA differential protective device is strongly advised.

Please refer to the installation and usage manual for the NAVISTEM B3000 boiler controller for information about the electrical connections to the control panel (electricity supply characteristics, cable section and connection to terminal blocks).

Refer to the VARMAX generator's installation, usage and maintenance manual for all information about accessing the generators' control panel and the cable runs.

4.14.1. Connecting the OCI345 communication modules

4.14.1.1. Installing the communication modules

The modules are installed on the NAVISTEM B3000 boiler controllers, located in the control panel for the 2 VARMAX generators.

On each VARMAX generator:

- Access the control panel and remove its protective cover.
- Secure the module to the boiler controller with the 2 screws supplied.

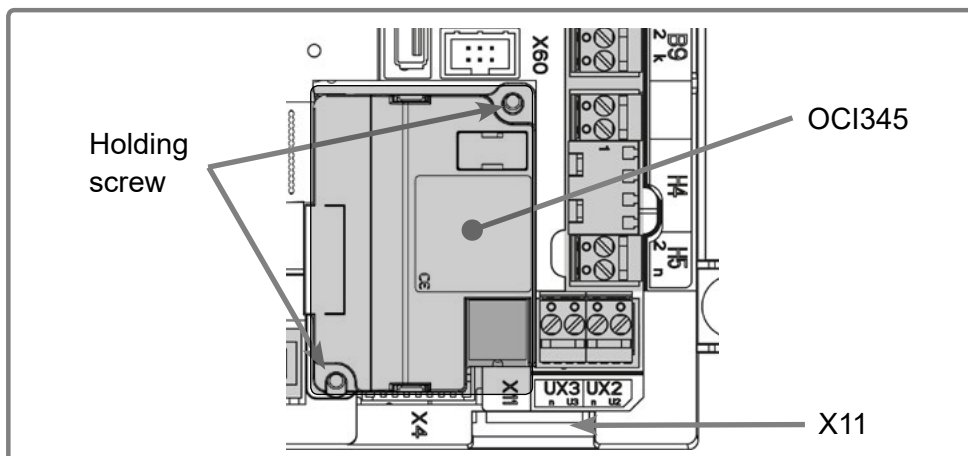

figure 12 - OCI345 attachment

- Connect the communication layer from the OCI345 module to the boiler controller's X11 connector (see previous figure).



IMPORTANT: Proceed carefully during connection.

4.14.1.2. Electrical connection

- Connect the VARMAX generators via the LPB bus (the LPB bus connects to the OCI345 communication module's DB and MB terminal blocks).

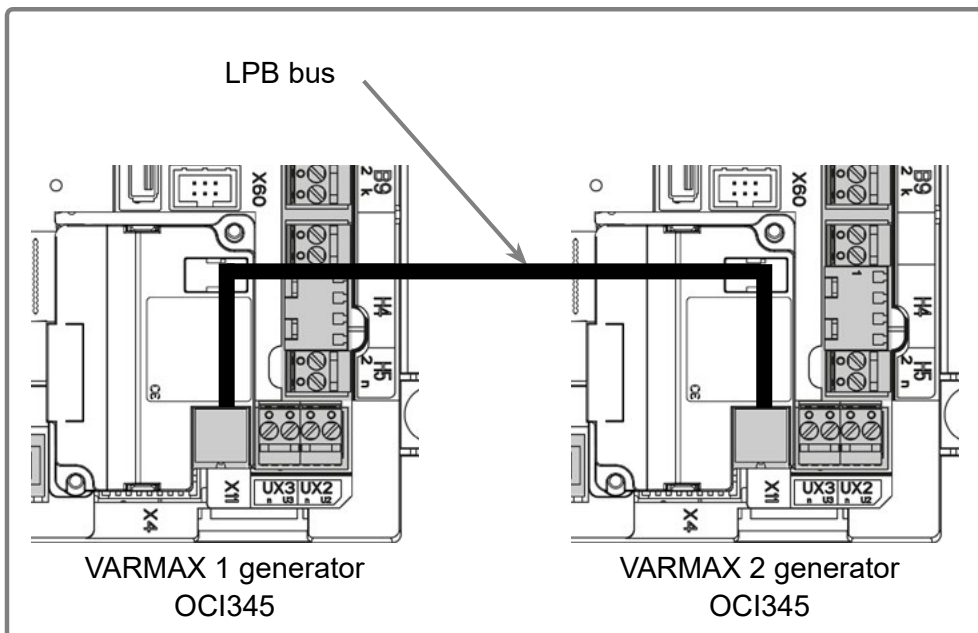

figure 13 - LPB bus connection



WARNING: The "LPB bus" cable must be run from generator 1's control panel to generator 2's control panel via the 2 generators' "low current" trays and via the "LPB bus cable run" trays (see § 4.3). Hold the cable using the cable clamps.

4.14.2. Connecting the QAZ36 flow sensor

4.14.2.1. Installing the sensor

The sensor must be placed in a pocket as close as possible to the 2 generators' common hydraulic output.

4.14.2.2. Electrical connection

- Connect the QAZ36 flow sensor to terminal block BX2 on generator 1's NAVISTEM B3000 boiler controller (see chapter 8).



WARNING:

The sensor cable must be run to generator 1's control panel via the "low current" tray. Hold the cable using the cable clamps.

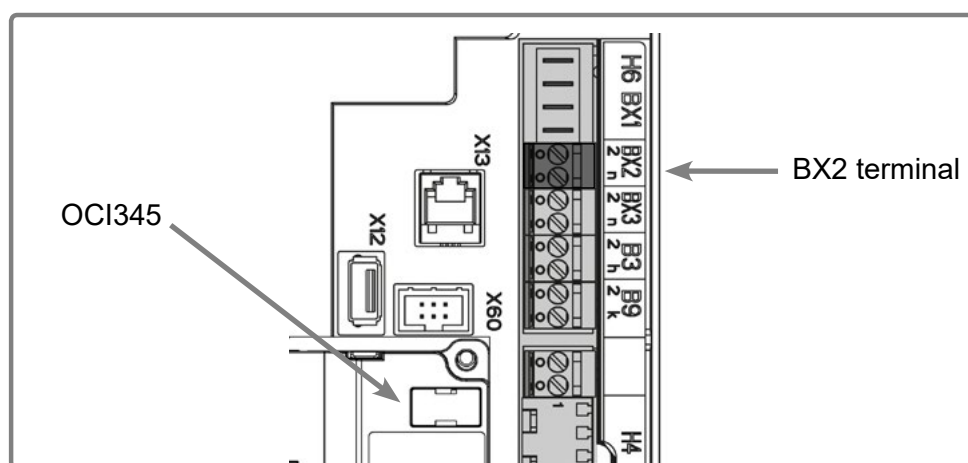

figure 14 - Flow sensor connection

4.14.3. Connection to the boiler controller's terminal blocks

Refer to the NAVISTEM B3000 boiler controller's manual.

5. START-UP (COMMISSIONING)

Refer to the VARMAX generator's installation, use and maintenance manual.

6. CHECKS AFTER COMMISSIONING







Refer to the VARMAX generator's installation, use and maintenance manual.

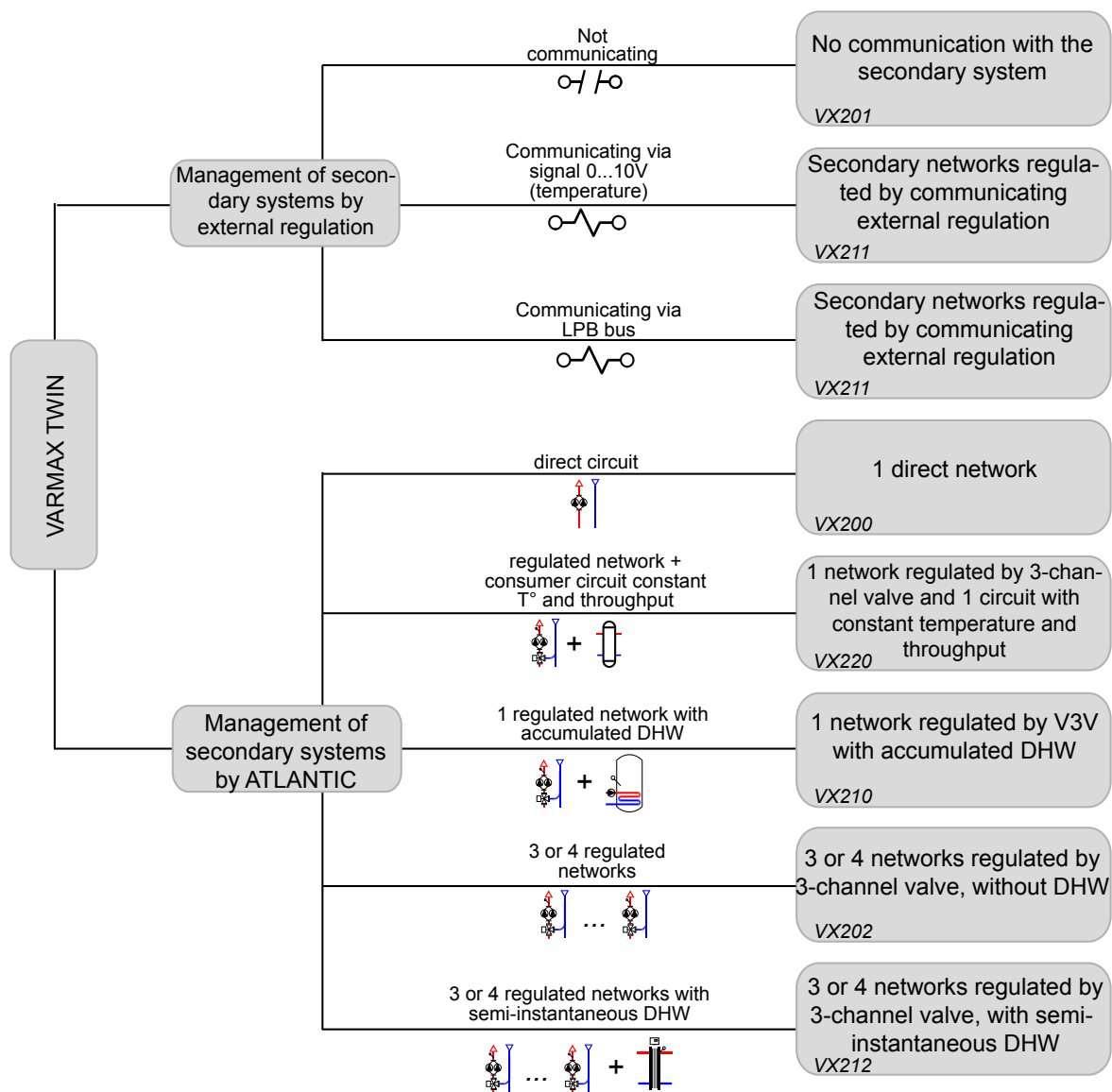





7. MAINTENANCE OPERATIONS

Refer to the VARMAX generator's installation, use and maintenance manual.

8. HYDRAULIC DIAGRAMS AND CONFIGURATIONS



Symbol	Function
	Isolation valve open
	2-channel powered valve
	Filter
	Safety unit
	Mud cup
	External sensor

Symbol	Function
	Balancing valve
	3-channel powered valve
	Anti-return flap
	Pump
	Bleed valve
	Temperature sensor

<p><i>1 direct network, no communication with the secondary</i></p>	<p>Diagram VX200 VX201 page 1 / 6</p>
---	---

A. MAIN AND VARIANT HYDRAULIC DIAGRAMS

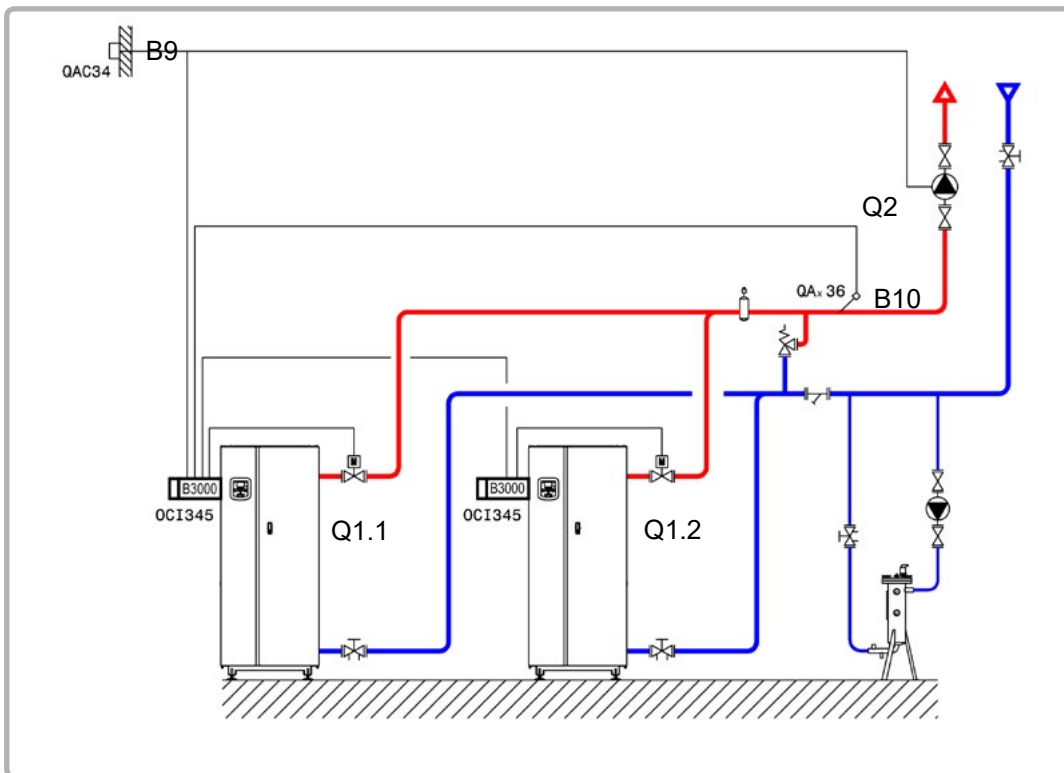

figure 15 - VX200 diagram

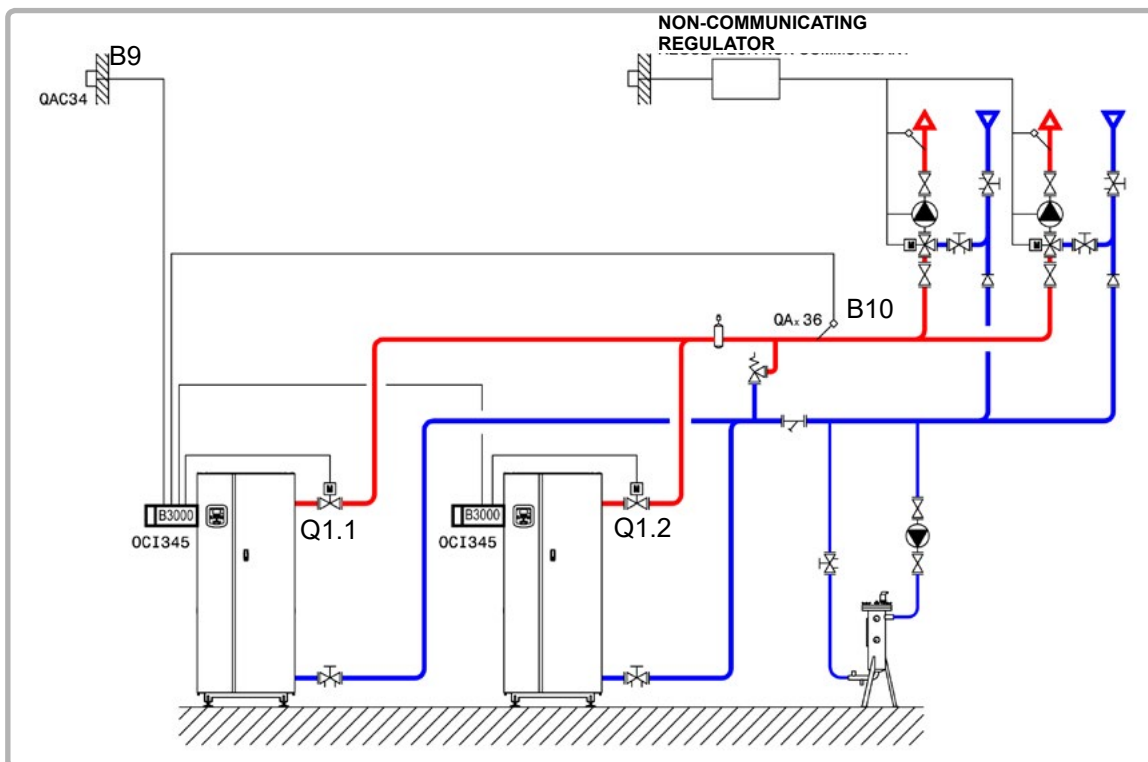

figure 16 - VX201 diagram (variant)

B. REGULATION ACCESSORIES REQUIRED

	Quantity	Appliance reference	Order No.
Communication kit	2	OCI 345	supplied
Communication cable	1	LPB BUS	supplied
Output sensor kit	1	QAZ 36	supplied
Output sensor kit	1	QAC 34	059260

C. CUSTOMER'S ELECTRICAL CONNECTION

Generator No. 1:



INFORMATION:

If the isolation valve is not equipped with an automatic reset valve, connect the Q1.1 isolating valve's closure contact to Y2.

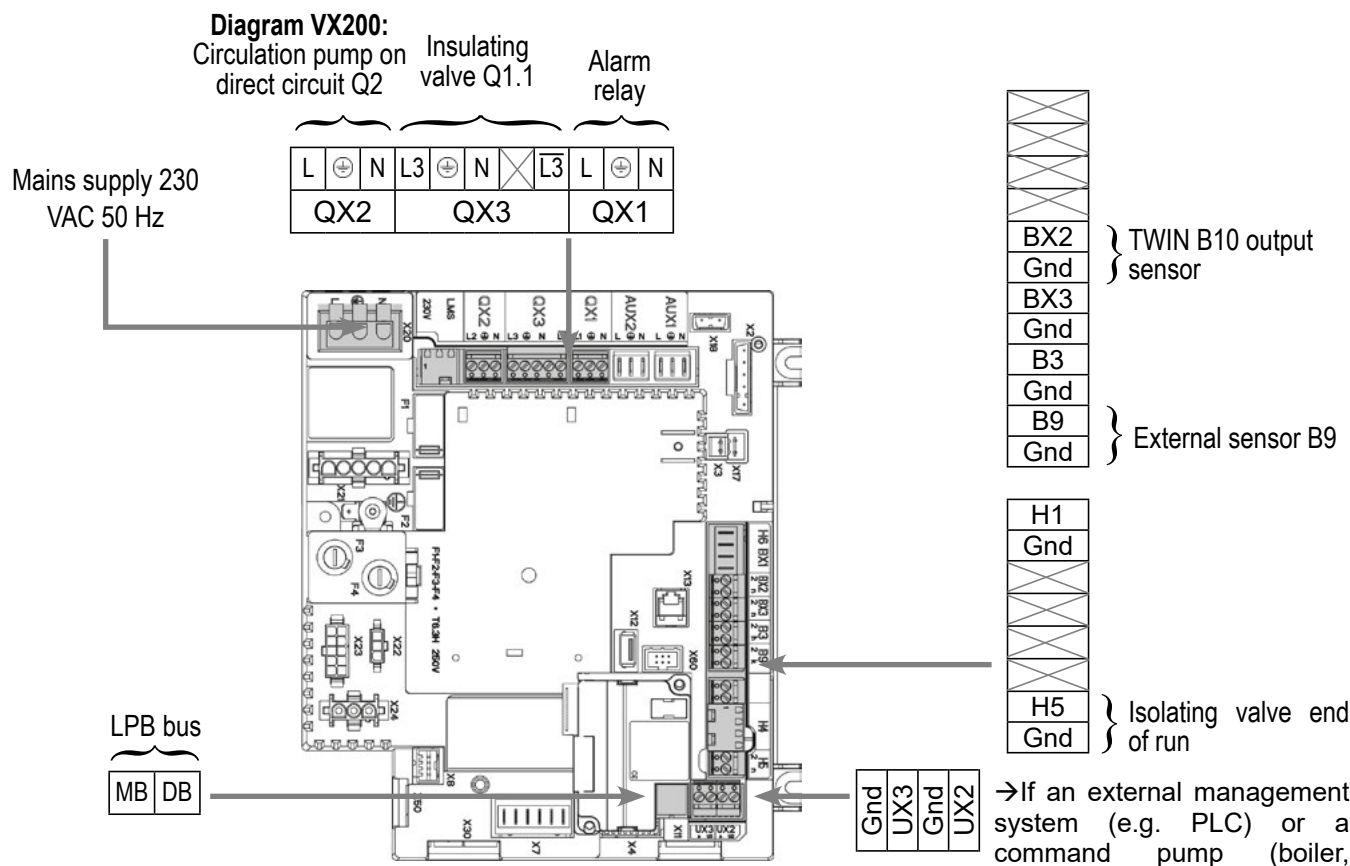

Generator No. 2:



INFORMATION:

If the isolation valve is not equipped with an automatic reset valve, connect the Q1.2 isolating valve's closure contact to Y2.

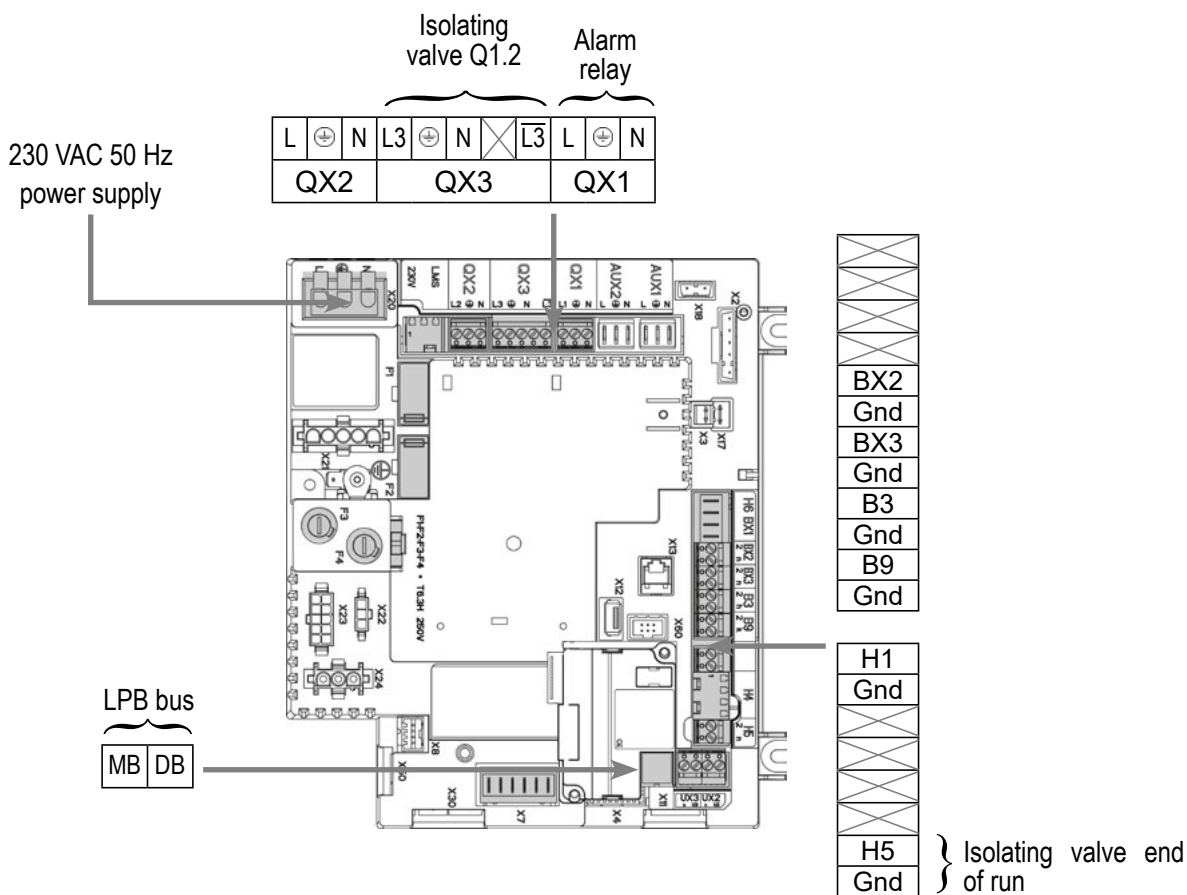

D. SPECIFIC START-UP PROCEDURE

- ☞ Make the accessories' electrical connections.
- ☞ Start up the generator on its own.
- ☞ Make the following settings:

On generator No. 1

	<i>Line No.</i>	<i>Value</i>
• Set the date and time: <u>Time and date</u> menu		
Set the time	Hour / minute (1)	HH.MM
Set the date	Day / month (2)	DD.MM
Set the year	Year (3)	YYYY
• Configure the isolating valve and its end of run: <u>Configuration</u> menu		
Valve command	Relay output QX3 (5892)	K37 exhaust flap
End of run	Input H5 (5977)	Exhaust flap info return
• <u>Configuration</u> menu		
Start up heating circuit 1	Heating circuit 1 (5710)	Start

	Line No.	Value
VX200 diagram only:		
Configure pump Q2	Relay output QX2 (5891)	Pump CC1 Q2
All diagrams:		
Configure TWIN B10 output sensor	BX2 sensor input (5931)	Common flow sensor B10
• Configure as generator No. 1: <u>LPB network</u> menu		
Appliance number	Appliance address (6600)	1
Segment number	Segment address (6601)	0
Adjust the bus supply	Bus supply function (6604)	Automatic
Adjust the clock rate	Clock operation (6640)	Master
Return the messages from generator 2	Display system messages (6610)	Yes
Activate relay K10 if generator 2 is at fault	Syst messages alarm relay (6611)	Yes
• Adjust the heating circuit <u>Heating circuit 1</u> menu		
Adjust the comfort setting	Comfort setting temperature (710)	---
Adjust the curve slope	Heating curve slope (720)	---
• Switch the heating regime to permanent comfort		
On generator No. 2		
• Configure the isolating valve and its end of run: <u>Configuration</u> menu		
Valve command	Relay output QX3 (5892)	K37 exhaust flap
End of run	Input H5 (5977)	Exhaust flap info return
• Configure as generator No. 2: <u>LPB network</u> menu		
Appliance number	Appliance address (6600)	2
Segment number	Segment address (6601)	0
Adjust the bus supply	Bus supply function (6604)	Automatic
Adjust the clock rate	Clock operation (6640)	Slave without adjustment
• Make sure that the communication cable is fully connected between the 2 generators (⚠ respect the polarity).		
• Switch off and back on again generator 2. If the communication has been correctly established, the clock is updated correctly.		

E. ELECTRICAL AND HYDRAULIC VALIDATION

On generator No. 1

	<i>Line No.</i>	<i>Value</i>
• <i>Flow diagnostic</i> menu		
Validate the presence of all the generators	Gener 1 status (8100)	Released / not released
	Gener 2 status (8101)	Released / not released
	
• <i>Inputs/outputs test</i> menu		
Check the outputs		
Alarm relay	Relay test (7700)	Relay output QX1
Pump Q2 (VX200 diagram)	Relay test (7700)	Relay output QX2
Isolating valve Q1.1	Relay test (7700)	Relay output QX3
Reset the outputs	Relay test (7700)	No test
Check the sensor values		
External sensor B9	External T° B9 (7730)	in °C
TWIN B10 output sensor	BX2 sensor T° (7821)	in °C
• <i>Configuration</i> menu		
Check the hydraulic diagram		
	Generator 1 inspection No. (6212)	14
	Generator 2 inspection No. (6213)	0
	DHW information (6215)	0
	Information about heating circuits 3, 2 and 1 (6217)	1

On generator No. 2

• <i>Inputs/outputs test</i> menu		
Check the outputs		
Alarm relay	Relay test (7700)	Relay output QX1
Isolating valve Q1.2	Relay test (7700)	Relay output QX3
Reset the outputs	Relay test (7700)	No test
• <i>Configuration</i> menu		
Check the hydraulic diagram		
	Generator 1 inspection No. (6212)	14
	Generator 2 inspection No. (6213)	0
	DHW information (6215)	0
	Information about heating circuits 3, 2 and 1 (6217)	0

F. CONFIGURATION OPTIMISATION

On generator No. 1

Heating circuit optimisation:

	<i>Line No.</i>	<i>Value</i>
• <u>Heating circuit 1</u> menu		
Adjust the reduced setting	Reduced setting temperature (712)	---
• <u>Heating circuit 1 timer programme</u> menu		
Preselection	Preselection (500)	---
Adjust the timer programming	On / off phases (501...506)	---
• <u>Heating circuit 1 holiday</u> menu		
Preselection	Preselection (641)	---
Adjust the timer programming	On / off phases (642--643)	---
Switch the heating regime to automatic		Auto

VARMAX TWIN optimisation:

The Varmax Twin may be optimised as necessary using the parameters in the **Flow** menu. Refer to the NAVISTEM B3000 boiler's controller manual for more details.

Maintenance optimisation

A maintenance message may be generated that does not set the generator to fault. This maintenance message may be displayed after the following 3 counters have expired:

- Time since last maintenance (or commissioning): set parameter 7044 to 12 months (**Maintenance / Special regime** menu)
- Burner's operating hours (parameter 7040 - menu **Maintenance / Special regime** menu)
- Number of starts (parameter 7042 - menu **Maintenance / Special regime** menu)

These last 2 parameters are dependent on the boiler's hydraulic installation. We recommend using at least parameter 7044 for annual maintenance.

Secondary networks regulated by external regulator communicating over LPB bus or 0...10V temperature

Diagram
VX211

page 1 / 6

A. HYDRAULIC DIAGRAM

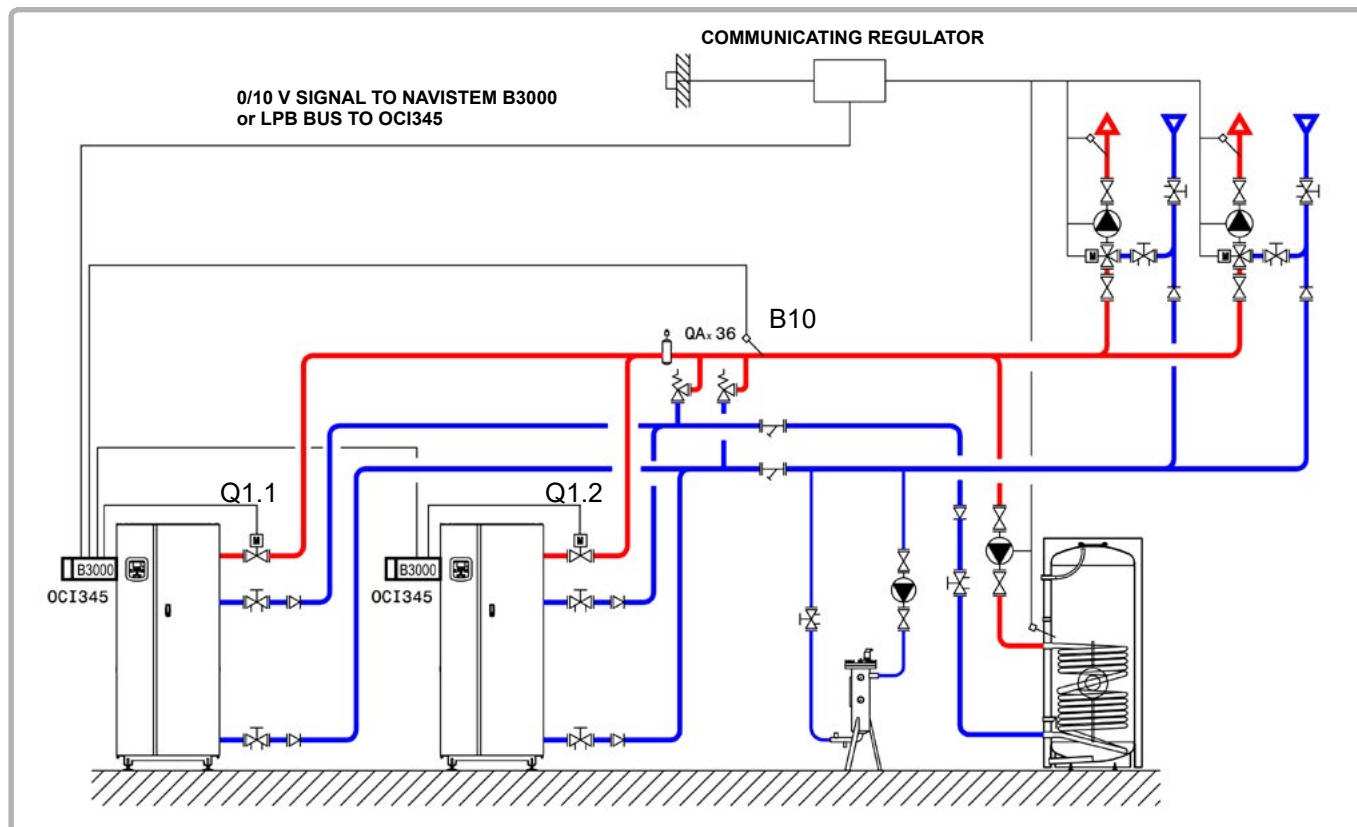

figure 17 - VX211 diagram

B. REGULATION ACCESSORIES REQUIRED

	Quantity	Appliance reference	Order No.
Communication kit	2	OCI 345	supplied
Communication cable	1	LPB BUS	supplied
Output sensor kit	1	QAZ 36	supplied

C. CUSTOMER'S ELECTRICAL CONNECTION

Generator No. 1:



INFORMATION:

If the isolation valve is not equipped with an automatic reset valve, connect the Q1.1 isolating valve's closure contact to Y2.

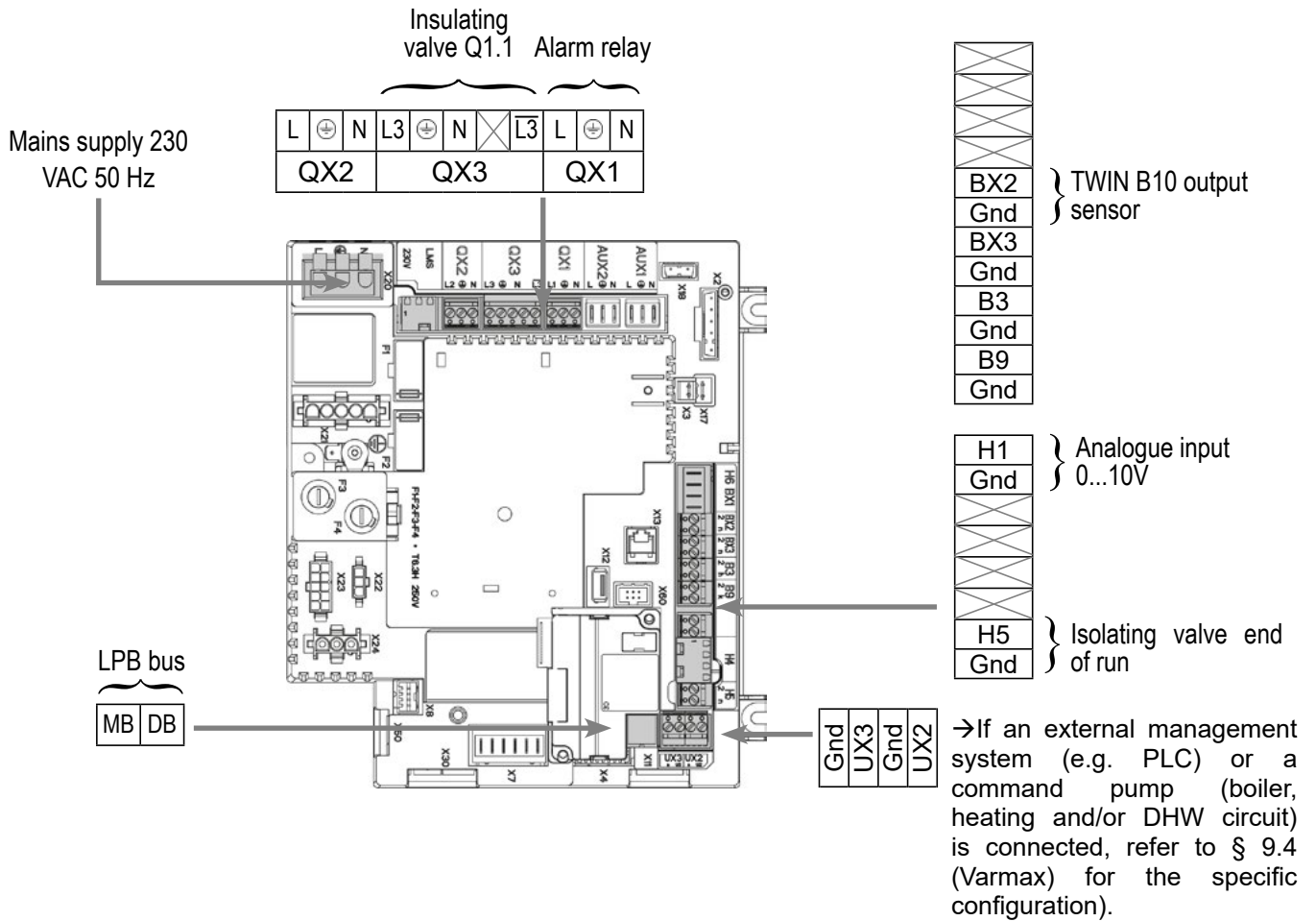

Generator No. 2:



INFORMATION:

If the isolation valve is not equipped with an automatic reset valve, connect the Q1.2 isolating valve's closure contact to Y2.

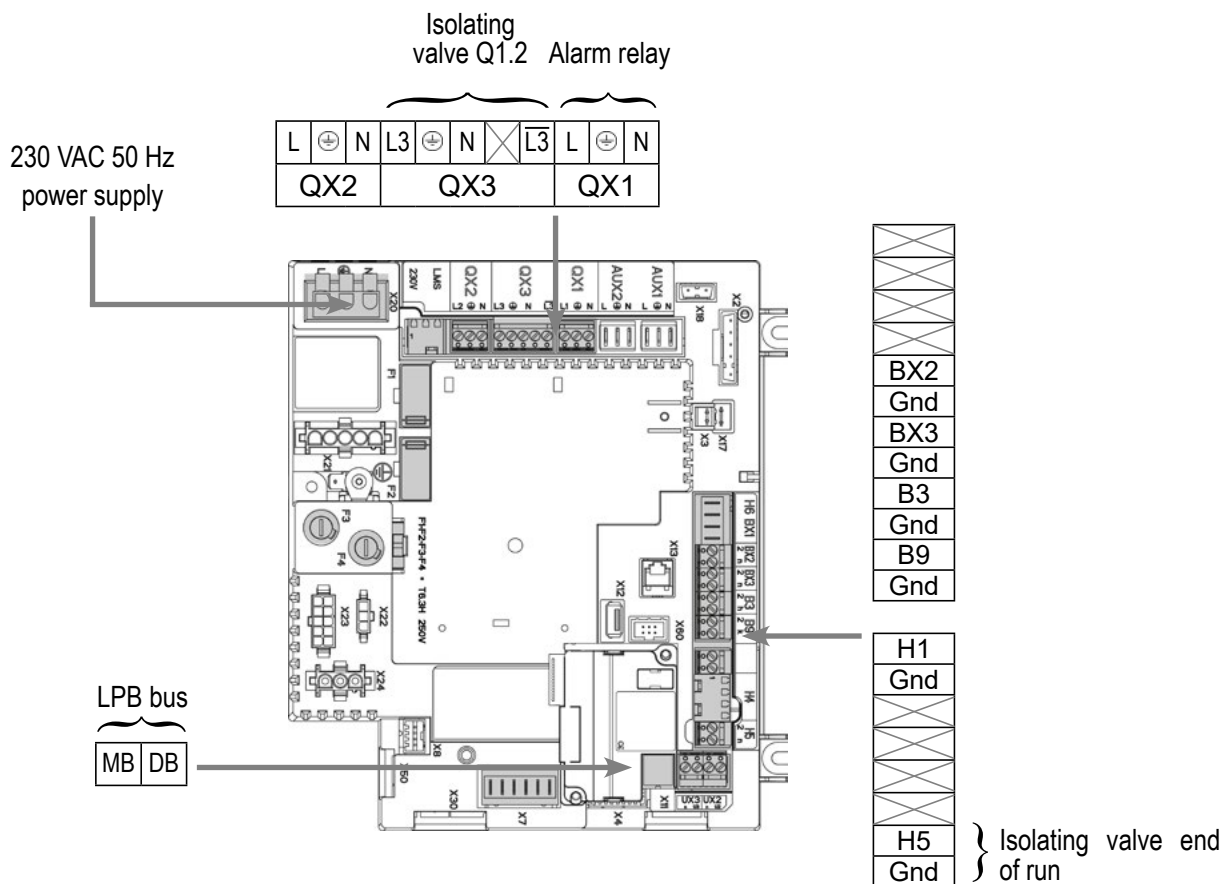

D. SPECIFIC START-UP PROCEDURE

- ☞ Make the accessories' electrical connections.
- ☞ Start up the generator on its own.
- ☞ Make the following settings:

On generator No. 1

• **Time and date menu**

- Set the time
- Set the date
- Set the year

Line No.	Value
Hour / minute (1)	HH.MM
Day / month (2)	DD.MM
Year (3)	YYYY
Relay output QX3 (5892)	K37 exhaust flap
Input H5 (5977)	Exhaust flap info return
BX2 sensor input (5931)	Common flow sensor B10

• **Configure the isolating valve and its end of run: Configuration menu**

- Valve command
- End of run

• **Configuration menu**

- Configure the TWIN B10 output sensor

	Line No.	Value
For a request via 0...10V input		
Configure the H1 input	H1 input function (5950)	10V consumption circ. request
	H1 voltage 1 value (5953)	0.0
	H1 function value (5954)	0
	H1 voltage 2 value (5955)	10.0
	H1 function 2 value (5956)	1000 (for equivalence 10 V = 100 °C)
For a request via LPB		
Check that the secondary regulatory is defined on an LPB segment other than 0 (reserved for the generators)		
In all cases (<u>LPB network</u> menu)		
Configure as generator No. 1	Appliance address (6600)	1
	Segment address (6601)	0
	Bus supply function (6604)	Automatic
	Clock operation (6640)	Master
Return the messages from generator 2	Display system messages (6610)	Yes
Activate relay K10 if generator 2 is at fault	Syst messages alarm relay (6611)	Yes
On generator No. 2		
• Configure the isolating valve and its end of run: <u>Configuration</u> menu		
Valve command	Relay output QX3 (5892)	K37 exhaust flap
End of run	Input H5 (5977)	Exhaust flap info return
• <u>LPB network</u> menu		
Configure as generator No. 2	Appliance address (6600)	2
	Segment address (6601)	0
	Bus supply function (6604)	Automatic
	Clock operation (6640)	Slave without adjustment
<ul style="list-style-type: none"> • Make sure that the communication cable is fully connected between the 2 generators (⚠ respect the polarity). • Switch off and back on again generator 2. If the communication has been correctly established, the clock is updated correctly. 		

E. ELECTRICAL AND HYDRAULIC VALIDATION

On generator No. 1

	<i>Line No.</i>	<i>Value</i>															
<ul style="list-style-type: none"> • <i>Flow diagnostic</i> menu <ul style="list-style-type: none"> Validate the presence of all the generators <table style="width: 100%; border-collapse: collapse; margin-top: 5px;"> <tr> <td style="width: 50%;"></td> <td style="width: 20%; text-align: center;">Gener 1 status (8100)</td> <td style="width: 30%;">Released / not released</td> </tr> <tr> <td></td> <td style="text-align: center;">Gener 2 status (8101)</td> <td>Released / not released</td> </tr> <tr> <td></td> <td style="text-align: center;">.....</td> <td></td> </tr> </table> 				Gener 1 status (8100)	Released / not released		Gener 2 status (8101)	Released / not released								
	Gener 1 status (8100)	Released / not released															
	Gener 2 status (8101)	Released / not released															
																
<p>For a request via 0...10V input</p> <ul style="list-style-type: none"> • <i>Inputs/outputs test</i> menu <ul style="list-style-type: none"> Voltage in H1 <table style="width: 100%; border-collapse: collapse; margin-top: 5px;"> <tr> <td style="width: 50%;"></td> <td style="width: 20%; text-align: center;">H1 voltage signal (7840)</td> <td style="width: 30%;">To be validated with the voltage sent by the boiler room's PLC</td> </tr> </table> 				H1 voltage signal (7840)	To be validated with the voltage sent by the boiler room's PLC												
	H1 voltage signal (7840)	To be validated with the voltage sent by the boiler room's PLC															
<p>For a request via LPB</p> <p>If the boiler room's regulator is configured as slave clock, it must retrieve the date and time.</p>																	
<ul style="list-style-type: none"> • <i>Inputs/outputs test</i> menu <ul style="list-style-type: none"> Check the outputs <table style="width: 100%; border-collapse: collapse; margin-top: 5px;"> <tr> <td style="width: 50%;">Alarm relay</td> <td style="width: 20%; text-align: center;">Relay test (7700)</td> <td style="width: 30%;">Relay output QX1</td> </tr> <tr> <td>Isolating valve Q1.1</td> <td style="text-align: center;">Relay test (7700)</td> <td>Relay output QX3</td> </tr> <tr> <td>Reset the outputs</td> <td style="text-align: center;">Relay test (7700)</td> <td>No test</td> </tr> </table> Check the sensor values <table style="width: 100%; border-collapse: collapse; margin-top: 5px;"> <tr> <td style="width: 50%;">External sensor B9</td> <td style="width: 20%; text-align: center;">External T° B9 (7730)</td> <td style="width: 30%;">in °C</td> </tr> <tr> <td>B1 flow sensor</td> <td style="text-align: center;">BX2 sensor T° (7821)</td> <td>in °C</td> </tr> </table> 			Alarm relay	Relay test (7700)	Relay output QX1	Isolating valve Q1.1	Relay test (7700)	Relay output QX3	Reset the outputs	Relay test (7700)	No test	External sensor B9	External T° B9 (7730)	in °C	B1 flow sensor	BX2 sensor T° (7821)	in °C
Alarm relay	Relay test (7700)	Relay output QX1															
Isolating valve Q1.1	Relay test (7700)	Relay output QX3															
Reset the outputs	Relay test (7700)	No test															
External sensor B9	External T° B9 (7730)	in °C															
B1 flow sensor	BX2 sensor T° (7821)	in °C															
<ul style="list-style-type: none"> • <i>Configuration</i> menu <ul style="list-style-type: none"> Check the hydraulic diagram <table style="width: 100%; border-collapse: collapse; margin-top: 5px;"> <tr> <td style="width: 50%;"></td> <td style="width: 20%; text-align: center;">Generator 1 inspection No. (6212)</td> <td style="width: 30%;">14</td> </tr> <tr> <td></td> <td style="text-align: center;">Generator 2 inspection No. (6213)</td> <td>0</td> </tr> <tr> <td></td> <td style="text-align: center;">DHW information (6215)</td> <td>0</td> </tr> <tr> <td></td> <td style="text-align: center;">Information about heating circuits 3, 2 and 1 (6217)</td> <td>0</td> </tr> </table> 				Generator 1 inspection No. (6212)	14		Generator 2 inspection No. (6213)	0		DHW information (6215)	0		Information about heating circuits 3, 2 and 1 (6217)	0			
	Generator 1 inspection No. (6212)	14															
	Generator 2 inspection No. (6213)	0															
	DHW information (6215)	0															
	Information about heating circuits 3, 2 and 1 (6217)	0															

On generator No. 2

	<i>Line No.</i>	<i>Value</i>
• <u>Inputs/outputs test</u> menu		
Check the outputs		
Alarm relay	Relay test (7700)	Relay output QX1
Isolating valve Q1.2	Relay test (7700)	Relay output QX3
Reset the outputs	Relay test (7700)	No test
• <u>Configuration</u> menu		
Check the hydraulic diagram	Generator 1 inspection No. (6212)	14
	Generator 2 inspection No. (6213)	0
	DHW information (6215)	0
	Information about heating circuits 3, 2 and 1 (6217)	0

F. CONFIGURATION OPTIMISATION

VARMAX TWIN optimisation:

The Varmax Twin may be optimised as necessary using the parameters in the **Flow** menu. Refer to the NAVISTEM B3000 boiler's controller manual for more details.

Maintenance optimisation

A maintenance message may be generated that does not set the generator to fault. This maintenance message may be displayed after the following 3 counters have expired:

- Time since last maintenance (or commissioning): set parameter 7044 to 12 months (**Maintenance / Special regime** menu)
- Burner's operating hours (parameter 7040 - menu **Maintenance / Special regime** menu)
- Number of starts (parameter 7042 - menu **Maintenance / Special regime** menu)

These last 2 parameters are dependent on the boiler's hydraulic installation. We recommend using at least parameter 7044 for annual maintenance.

<p><i>1 network regulated by three-channel valve, DHW production, or 1 direct circuit with constant temperature and flow rate</i></p>	<p>Diagram VX210 VX220 page 1 / 8</p>
---	---

A. HYDRAULIC DIAGRAM

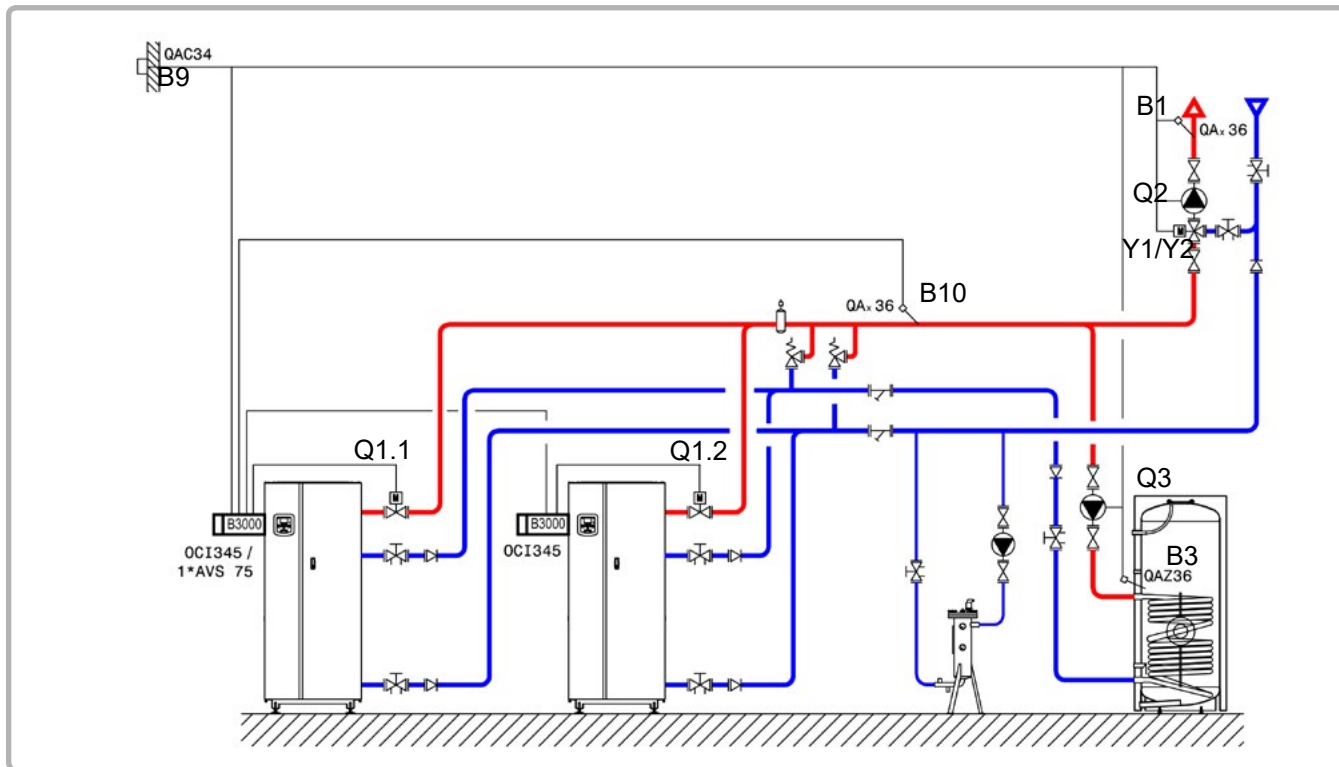

figure 18 - VX210 diagram

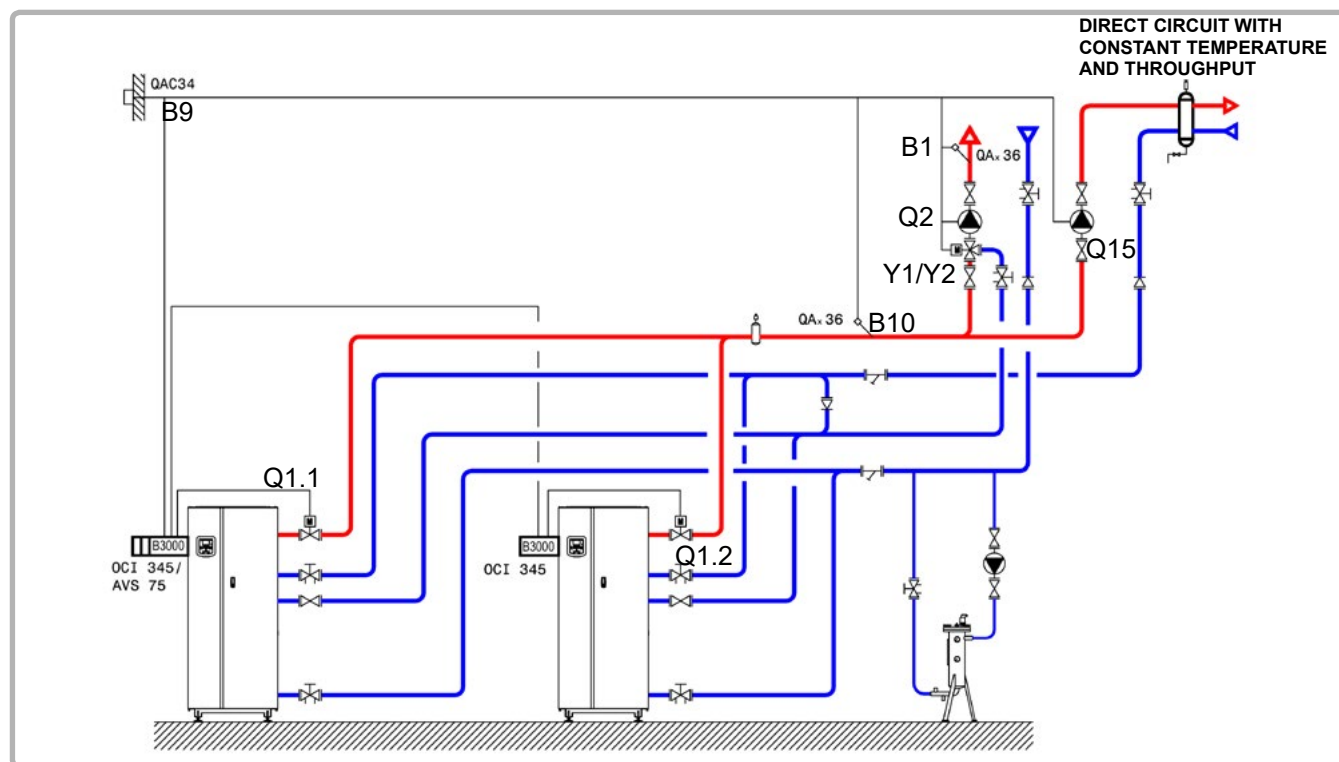

figure 19 - VX220 diagram

B. REGULATION ACCESSORIES REQUIRED

	Quantity	Appliance reference	Order No.
Extension module kit (delivered with a network sensor QAD 36)	1	AVS 75	059751
Communication kit	2	OCI 345	supplied
Communication cable	1	LPB BUS	supplied
Output sensor kit	1	QAZ 36	supplied
DHW sensor kit (diagram VX210)	1	QAZ 36	059261
Output sensor kit	1	QAC 34	059260

C. CUSTOMER'S ELECTRICAL CONNECTION

Generator No. 1:



INFORMATION:

If the isolation valve is not equipped with an automatic reset valve, connect the Q1.1 isolating valve's closure contact to Y2.

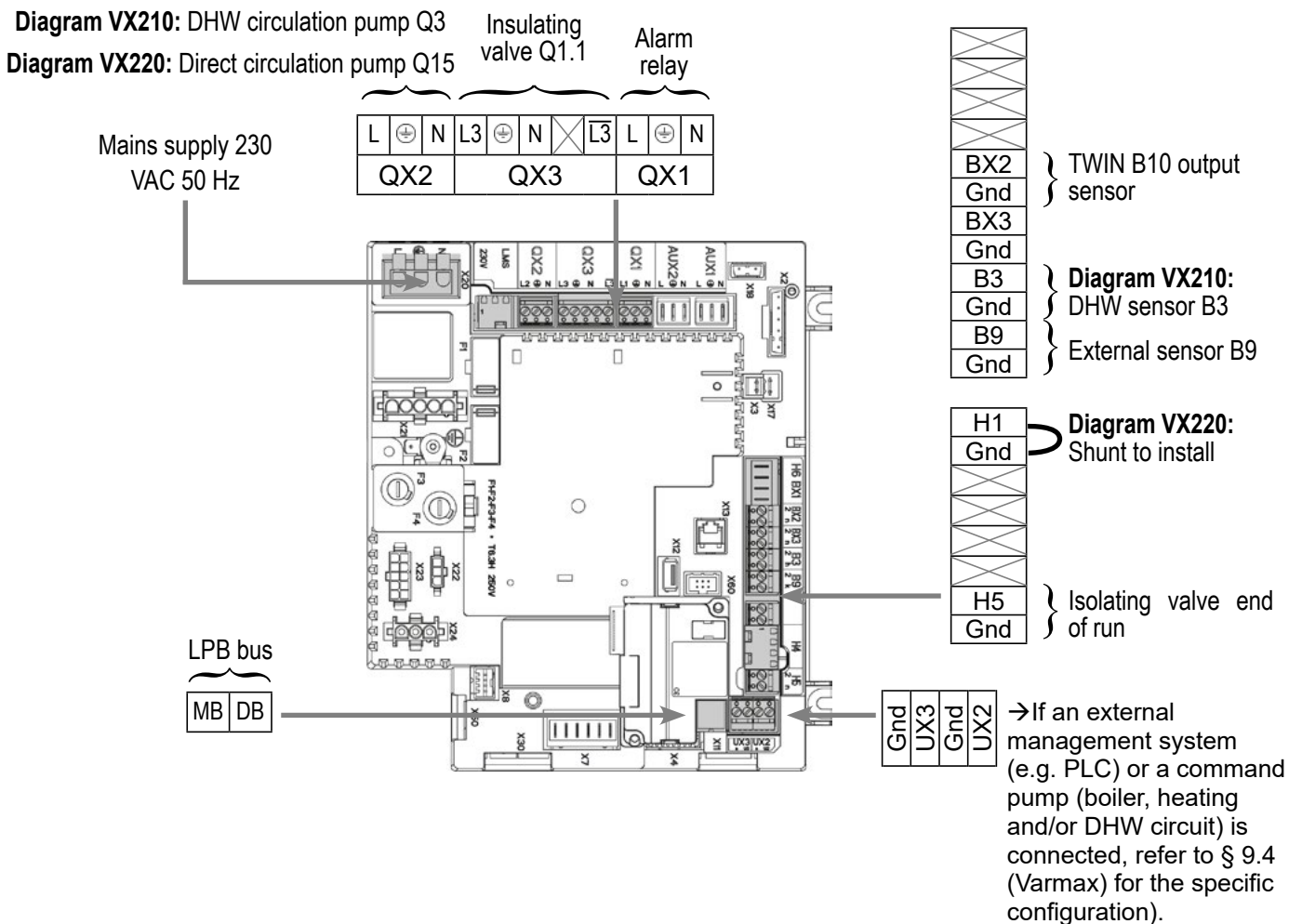

Diagrams: VX210 / VX220 page 3 / 8

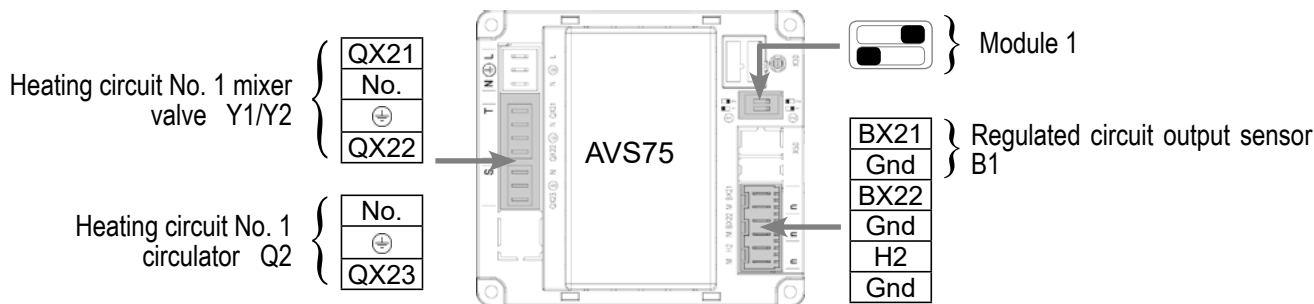

Generator No. 2:



INFORMATION:

If the isolation valve is not equipped with an automatic reset valve, connect the Q1.2 isolating valve's closure contact to Y2.

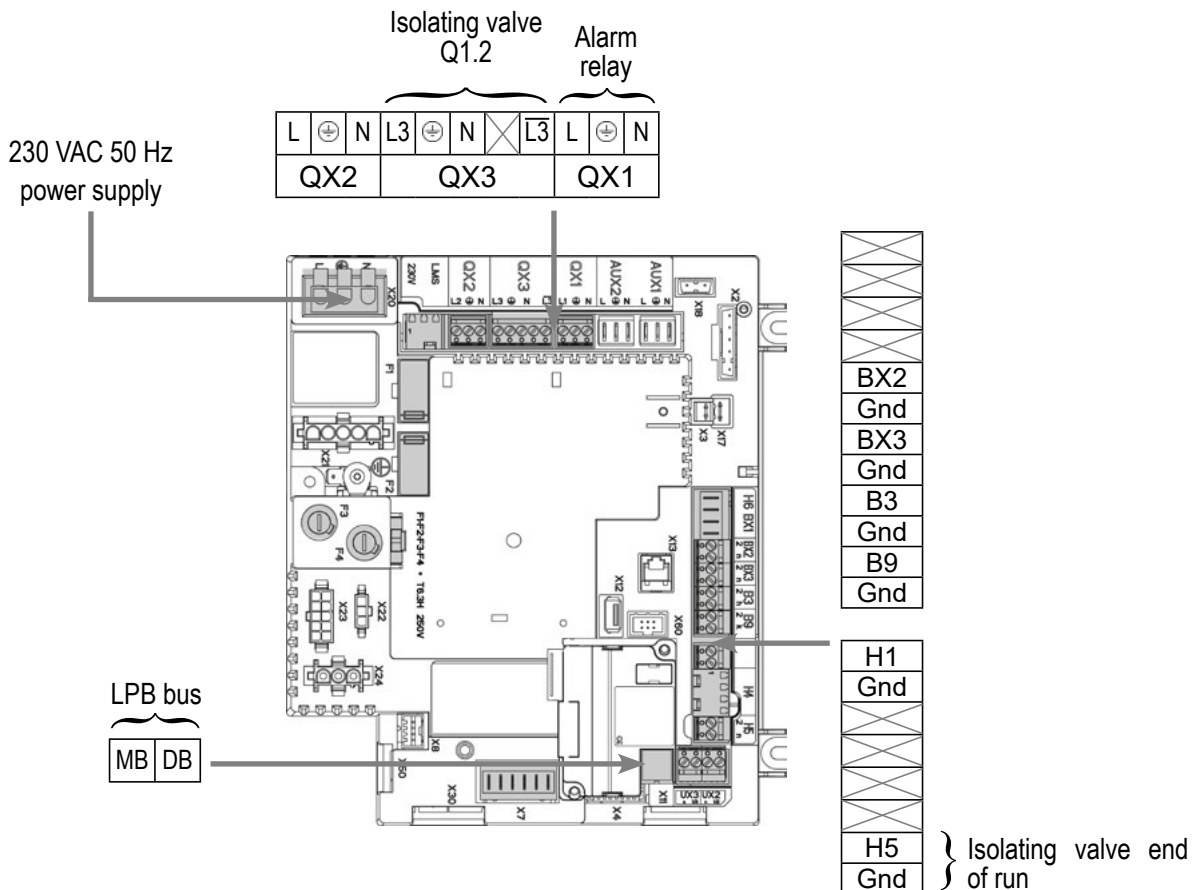

D. SPECIFIC START-UP PROCEDURE

☞ Make the accessories' electrical connections.



IMPORTANT: Configure the switches on the AVS75 extension module.



☞ Start up the generator on its own.

☞ Make the following settings:

On generator No. 1

	<i>Line No.</i>	<i>Value</i>
• <u>Time and date</u> menu		
Set the time	Hour / minute (1)	HH.MM
Set the date	Day / month (2)	DD.MM
Set the year	Year (3)	YYYY
• Configure the isolating valve and its end of run: <u>Configuration</u> menu		
Valve command	Relay output QX3 (5892)	K37 exhaust flap
End of run	Input H5 (5977)	Exhaust flap info return
• <u>Configuration</u> menu		
Configure the DHW pump (VX210 diagram)	Relay output QX2 (5891)	DHW pump/valve Q3
Configure the Q15 pump (VX220 diagram)	Relay output QX2 (5891)	Consumption circuit pump 1 Q15
Configure the TWIN B10 output sensor	BX2 sensor input (5931)	Common flow sensor B10
Configure the H1 input (VX220 diagram)	H1 input function (5977)	Consumption circuit 1 request
Configure the extension module	Extension module 1 function 1 (6020)	Heating circuit 1
• Configure as generator No. 1: <u>LPB network</u> menu		
Appliance number	Appliance address (6600)	1
Segment number	Segment address (6601)	0
Adjust the bus supply	Bus supply function (6604)	Automatic
Adjust the clock rate	Clock operation (6640)	Master
Return the messages from generator 2	Display system messages (6610)	Yes
Activate relay K10 if generator 2 is at fault	Syst messages alarm relay (6611)	Yes

Diagrams: VX210 / VX220	page 5 / 8
--------------------------------	------------

	<i>Line No.</i>	<i>Value</i>
<ul style="list-style-type: none"> • <u>Heating circuit 1</u> menu 		
Adjust the comfort setting	Comfort setting temperature (710)	---
Adjust the curve slope	Heating curve slope (720)	---
• Switch the heating regime to permanent comfort		
VX210 diagram only:		
<ul style="list-style-type: none"> • <u>Domestic hot water</u> menu 		
Adjust the comfort setting	Comfort setting (1610)	---
• Activate the DHW mode		
VX220 diagram only:		
<ul style="list-style-type: none"> • <u>Consumption circuit 1</u> menu 		
Set the output setting to be taken into account if the consumption circuit is requested	Cons request output T° (1859)	---
 On generator No. 2		
<ul style="list-style-type: none"> • Configure the isolating valve and its end of run: <u>Configuration</u> menu 		
Valve command	Relay output QX3 (5892)	K37 exhaust flap
End of run	Input H5 (5977)	Exhaust flap info return
<ul style="list-style-type: none"> • Configure as generator No. 2: <u>LPB network</u> menu 		
Appliance number	Appliance address (6600)	2
Segment number	Segment address (6601)	0
Adjust the bus supply	Bus supply function (6604)	Automatic
Adjust the clock rate	Clock operation (6640)	Slave without adjustment
<ul style="list-style-type: none"> • Make sure that the communication cable is fully connected between the 2 generators ( respect the polarity). • Switch off and back on again generator 2. If the communication has been correctly established, the clock is updated correctly. 		

E. ELECTRICAL AND HYDRAULIC VALIDATION

On generator No. 1

	Line No.	Value
• <u>Flow diagnostic</u> menu		
Validate the presence of all the generators	Gener 1 status (8100)	Released / not released
	Gener 2 status (8101)	Released / not released
	
• <u>Inputs/outputs test</u> menu		
Check the outputs		
Alarm relay	Relay test (7700)	Relay output QX1
DHW pump Q3 (VX210 diagram)	Relay test (7700)	Relay output QX2
Constant circuit pump Q15 (VX220 diagram)	Relay test (7700)	Relay output QX2
Heating circuit 3-channel valve opening	Relay test (7700)	Relay output QX21 module 1
Heating circuit 3-channel valve closure	Relay test (7700)	Relay output QX22 module 1
Heating circuit pump	Relay test (7700)	Relay output QX23 module 1
Reset the outputs	Relay test (7700)	No test
Check the sensor values		
External sensor B9	External T° B9 (7730)	in °C
DHW sensor B3	DHW temperature B3/B38 (7750)	in °C
B1 flow sensor	Temperature sensor BX21 module 1 (7830)	in °C
• <u>Configuration</u> menu		
Check the hydraulic diagram	Generator 1 inspection No. (6212)	14
	Generator 2 inspection No. (6213)	0
	DHW information (6215)	4 (VX210 diagram) 0 (VX220 diagram)
	Information about heating circuits 3, 2 and 1 (6217)	3

On generator No. 2

	<i>Line No.</i>	<i>Value</i>
• <u>Inputs/outputs test</u> menu		
Check the outputs		
Alarm relay	Relay test (7700)	Relay output QX1
Isolating valve Q1.2	Relay test (7700)	Relay output QX3
Reset the outputs	Relay test (7700)	No test
• <u>Configuration</u> menu		
Check the hydraulic diagram		
	Generator 1 inspection No. (6212)	14
	Generator 2 inspection No. (6213)	0
	DHW information (6215)	0
	Information about heating circuits 3, 2 and 1 (6217)	0

F. CONFIGURATION OPTIMISATION

Heating circuit optimisation:

• <u>Heating circuit 1</u> menu		
Adjust the reduced setting	Reduced setting temperature (712)	---
• <u>Heating circuit 1 timer programme</u> menu		
Preselection	Preselection (500)	---
Adjust the timer programming	On / off phases (501...506)	---
• <u>Heating circuit 1 holiday</u> menu		
Preselection	Preselection (641)	---
Adjust the timer programming	On / off phases (642--643)	---
• Switch the heating regime to automatic		Auto

DHW optimisation:

• <u>Domestic hot water</u> menu		
Adjust the comfort setting	Reduced setting (1612)	---

Adjust the DHW release mode	DHW release (1620)	Timer program 4/ DHW
	Line No.	Value
<ul style="list-style-type: none"> • <u>Timer programme 4/DHW</u> menu 		
Preselection	Preselection (560)	---
Adjust the timer programming	On / off phases (561...566)	---
<ul style="list-style-type: none"> • <u>DHW tank</u> menu 		
Adjust the over value	Output setting temperature over value (5020)	---
<u>VX210 diagram only:</u>		
<ul style="list-style-type: none"> • <u>Domestic hot water</u> menu 		
Configure an Anti-Legionnaires' Disease function	Anti-Legionnaires' Disease function (1640)	---
	Periodic Anti-Legionnaires' Disease function (1641)	---
	Day week Anti-Legionnaires' Disease function (1642)	---
	Anti-Legionnaires' Disease setting temperature (1645)	---
	Anti-Legionnaires' Disease function duration (1646)	---

VARMAX TWIN optimisation:

The Varmax Twin may be optimised as necessary using the parameters in the **Flow** menu. Refer to the NAVISTEM B3000 boiler's controller manual for more details.

Maintenance optimisation

A maintenance message may be generated that does not set the generator to fault. This maintenance message may be displayed after the following 3 counters have expired:

- Time since last maintenance (or commissioning): set parameter 7044 to 12 months (**Maintenance / Special regime** menu)
- Burner's operating hours (parameter 7040 - menu **Maintenance / Special regime** menu)
- Number of starts (parameter 7042 - menu **Maintenance / Special regime** menu)

These last 2 parameters are dependent on the boiler's hydraulic installation. We recommend using at least parameter 7044 for annual maintenance.

<p><i>3 or 4 networks regulated by three-channel valve, with or without DHW production</i></p>	<p>Diagram VX202 VX212 page 1 / 9</p>
--	---

A. MAIN AND VARIANT HYDRAULIC DIAGRAMS

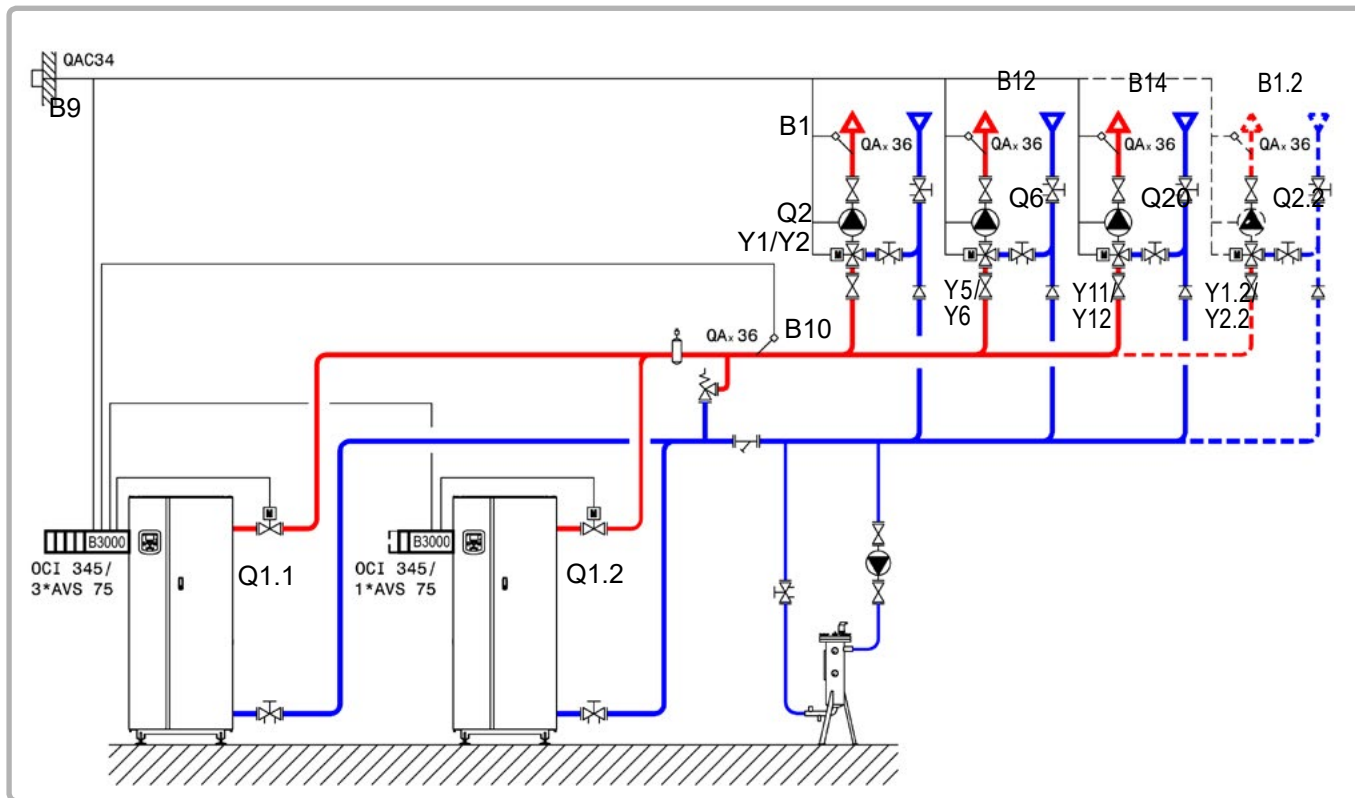

figure 20 - VX202 diagram

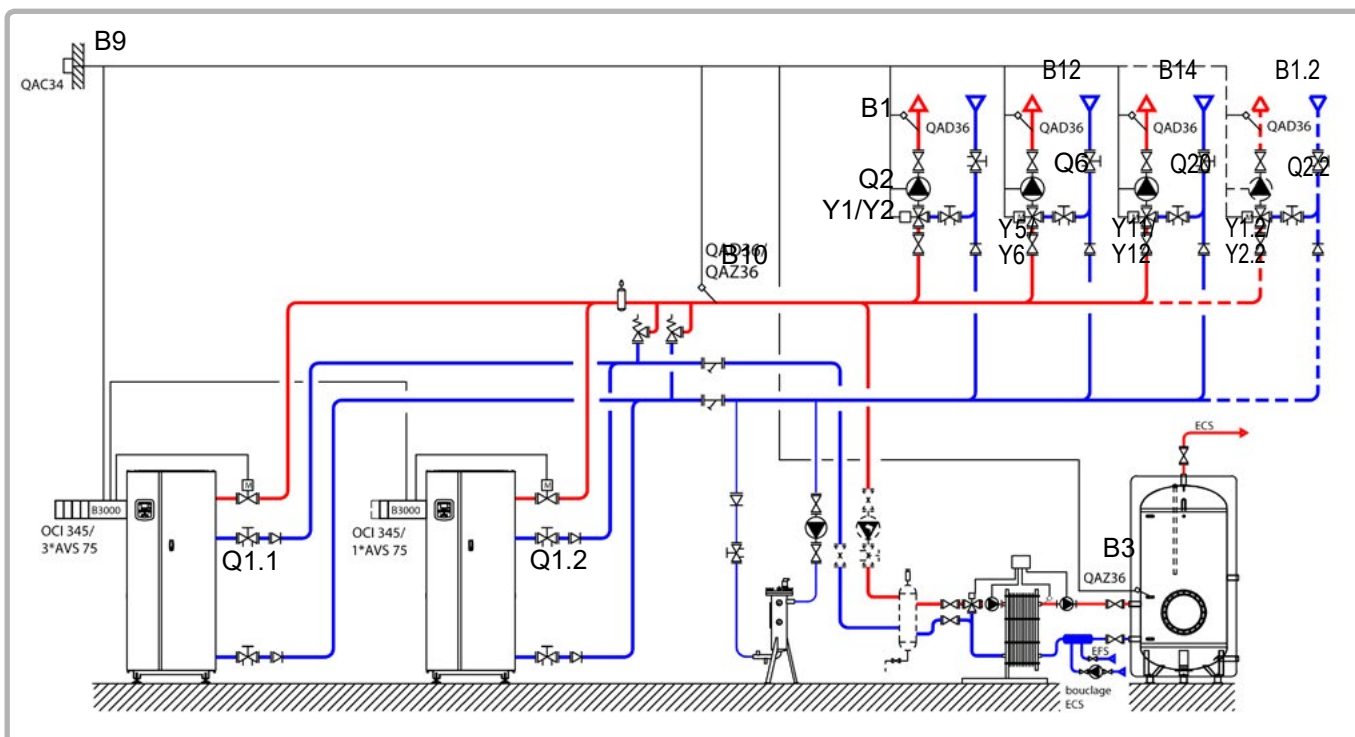

figure 21 - VX212 diagram (variant)

B. REGULATION ACCESSORIES REQUIRED

	Quantity	Appliance reference	Order No.
Extension module kit (delivered with a network sensor QAD 36)	3 (4)	AVS 75	059751
Communication kit	2	OCI 345	supplied
Communication cable	1	LPB BUS	supplied
Output sensor kit	1	QAZ 36	supplied
Output sensor kit	1	QAC 34	059260
DHW sensor kit (VX212 diagram)	1	QAZ 36	059261

C. CUSTOMER'S ELECTRICAL CONNECTION

Generator No. 1:



INFORMATION:

If the isolation valve is not equipped with an automatic reset valve, connect the Q1.1 isolating valve's closure contact to Y2.

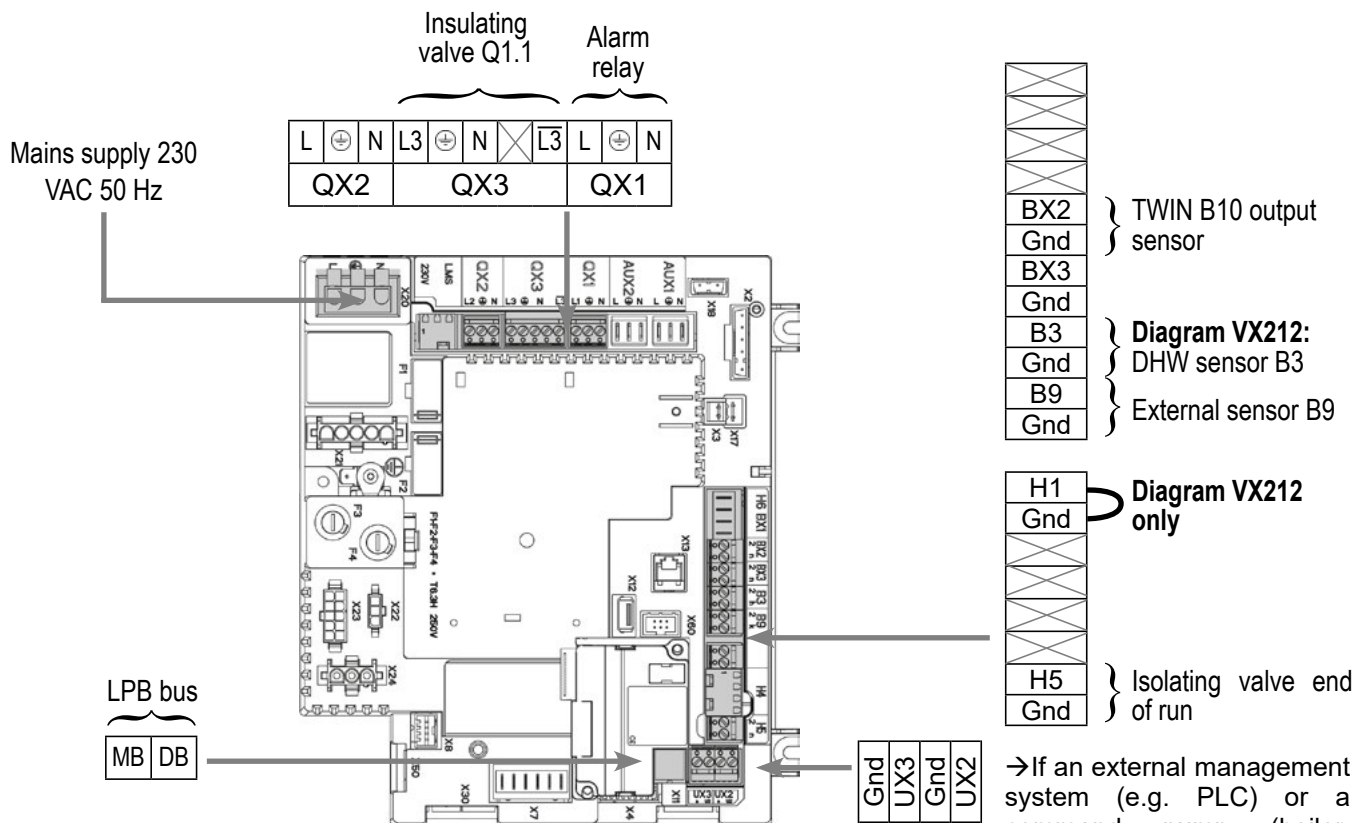

→ If an external management system (e.g. PLC) or a command pump (boiler, heating and/or DHW circuit) is connected, refer to § 9.4 (Varmax) for the specific configuration.

Diagrams: VX202 / VX212 page 3 / 9

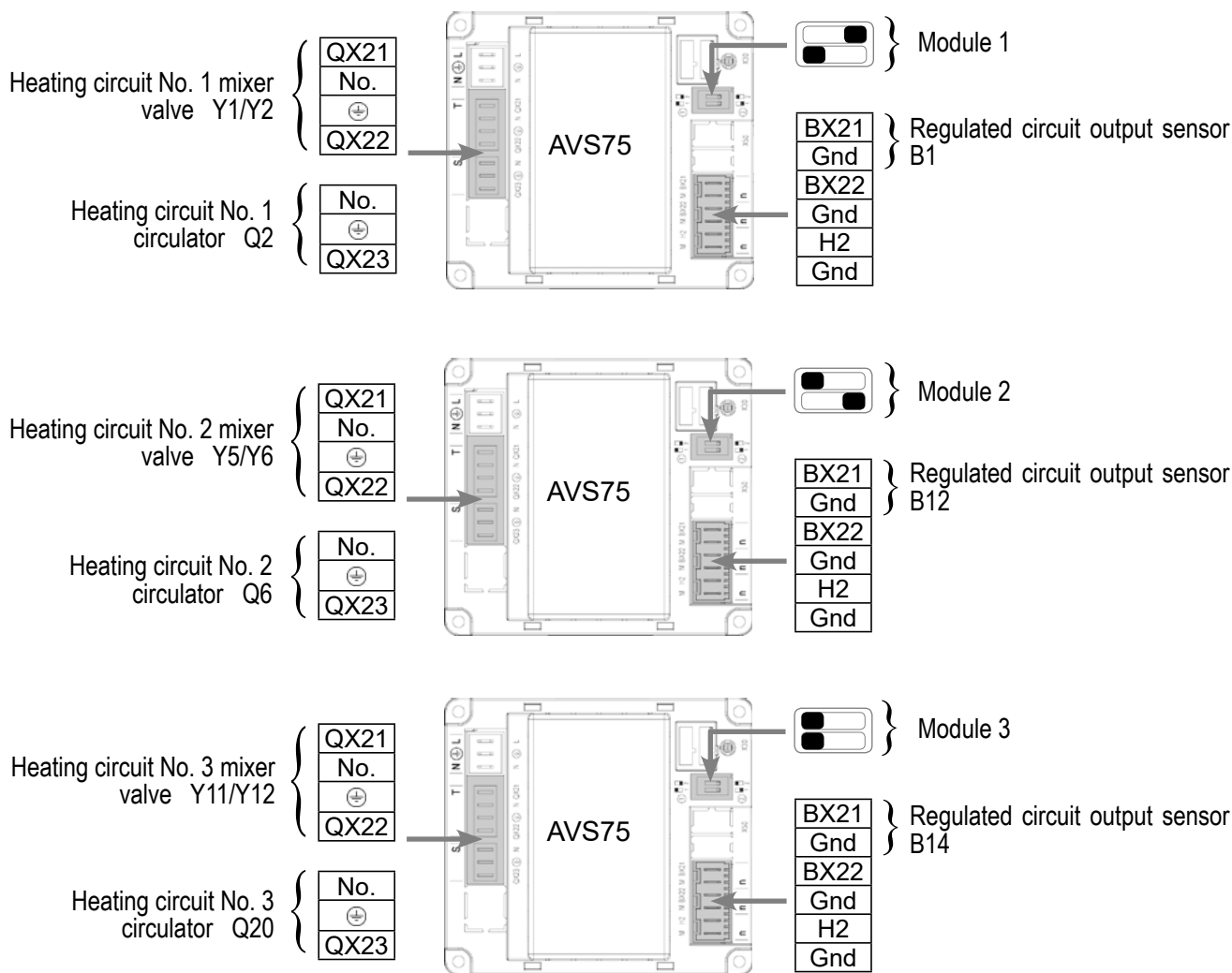

Generator No. 2:



INFORMATION:

If the isolation valve is not equipped with an automatic reset valve, connect the Q1.2 isolating valve's closure contact to Y2.

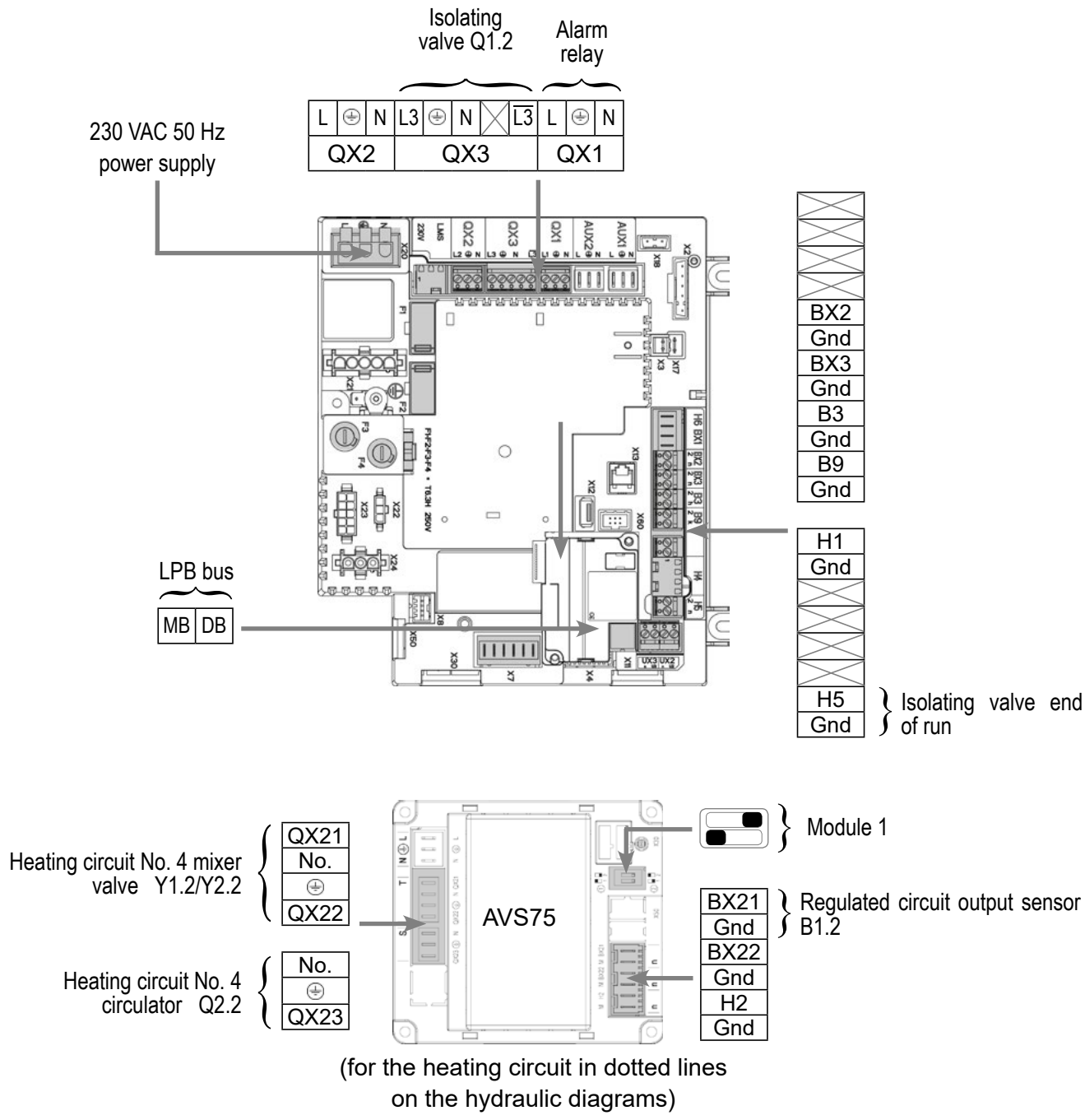

D. SPECIFIC START-UP PROCEDURE

☞ Make the accessories' electrical connections.





IMPORTANT: Configure the switches on the AVS75 extension modules.

☞ Start up the generator on its own.

☞ Carry out the adjustments below.

On generator No. 1

	<i>Line No.</i>	<i>Value</i>
• <u>Time and date</u> menu		
Set the time	Hour / minute (1)	HH.MM
Set the date	Day / month (2)	DD.MM
Set the year	Year (3)	YYYY
• Configure the isolating valve and its end of run: <u>Configuration</u> menu		
Valve command	Relay output QX3 (5892)	K37 exhaust flap
End of run	Input H5 (5977)	Exhaust flap info return
• <u>Configuration</u> menu		
Start up heating circuit 1	Heating circuit 2 (5710)	Start
Start up heating circuit 2	Heating circuit 2 (5715)	Start
Start up heating circuit 3	Heating circuit 3 (5721)	Start
VX212 diagram only:		
Define a low heel	H1 input function (5950)	Consumption circuit 1 request .
Position a shunt on H1 OR reverse the contact direction	Contact type (5951)	Normally-closed contact (NC)
For the DHW to be effective, an activator must be defined, even if it is not connected	Relay output QX2 (5891)	DHW pump/valve Q3
Configure pump Q1	Relay output QX3 (5892)	Boiler pump Q1
Configure TWIN B10 output sensor	BX2 sensor input (5931)	Common flow sensor B10
Configure the extension modules	Extension module 1 function 1 (6020)	Heating circuit 1
	Extension module 2 function 1 (6021)	Heating circuit 2
	Extension module 3 function 1 (6022)	Heating circuit 3
• Configure as generator No. 1: <u>LPB network</u> menu		
Appliance number	Appliance address (6600)	1
Segment number	Segment address (6601)	0
Adjust the bus supply	Bus supply function (6604)	Automatic
Adjust the clock rate	Clock operation (6640)	Master
Return the messages from generator 2	Display system messages (6610)	Yes
Activate relay K10 if generator 2 is at fault	Syst messages alarm relay (6611)	Yes

	<i>Line No.</i>	<i>Value</i>
<ul style="list-style-type: none"> • Heating circuit 1 / 2 / 3 menu 		
Adjust the comfort setting	Comfort setting temperature (710/1010/1310)	---
Adjust the curve slope	Heating curve slope (720/1020/1320)	---
<ul style="list-style-type: none"> • Switch the heating regime to permanent comfort 		
VX212 diagram only:		
<ul style="list-style-type: none"> • <u>Consumption circuit 1</u> menu 		
Set the output setting to be taken into account if the consumption circuit is requested	Cons request output setting (1859)	60 °C (depends on the Rubis setting)
<ul style="list-style-type: none"> • <u>Domestic hot water</u> menu 		
Adjust the comfort setting	Comfort setting (1610)	55 °C
Adjust the DHW release mode	DHW release (1620)	24/24
<ul style="list-style-type: none"> • Activate the DHW mode 		
On generator No. 2		
<ul style="list-style-type: none"> • Configure the isolating valve and its end of run: <u>Configuration</u> menu 		
Valve command	Relay output QX3 (5892)	K37 exhaust flap
End of run	Input H5 (5977)	Exhaust flap info return
<ul style="list-style-type: none"> • <u>Configuration</u> menu 		
<i>If 4th heating circuit present:</i> Start up heating circuit 1		
Configure the extension module	Heating circuit 1 (5710) Extension module 1 function 1 (6020)	Start Heating circuit 1
<ul style="list-style-type: none"> • Configure as generator No. 2: <u>LPB network</u> menu 		
Appliance number	Appliance address (6600)	2
Segment number	Segment address (6601)	0
Adjust the bus supply	Bus supply function (6604)	Automatic
Adjust the clock rate	Clock operation (6640)	Slave without adjustment

	<i>Line No.</i>	<i>Value</i>
<i>If 4th heating circuit present:</i>		
• Adjust the heating circuit <u>Heating circuit 1</u> menu		
Adjust the comfort setting	Comfort setting temperature (710)	---
Adjust the curve slope	Heating curve slope (720)	---
• Switch the heating regime to permanent comfort		
• Make sure that the communication cable is fully connected between the 2 generators (respect the polarity).		
• Switch off and back on again generator 2. If the communication has been correctly established, the clock is updated correctly.		

E. ELECTRICAL AND HYDRAULIC VALIDATION

On generator No. 1

	<i>Line No.</i>	<i>Value</i>
• <u>Flow diagnostic</u> menu		
Validate the presence of all the generators		
	Gener 1 status (8100)	Released / not released
	Gener 2 status (8101)	Released / not released
	
• <u>Inputs/outputs test</u> menu		
Check the outputs		
Alarm relay	Relay test (7700)	Relay output QX1
Isolating valve Q1.1	Relay test (7700)	Relay output QX3
All the extension module relays	Relay test (7700)	Relay output QX2... module ...
Reset the outputs	Relay test (7700)	No test
Check the sensor values		
External sensor B9	External T° B9 (7730)	in °C
DHW sensor B3 (VX212 diagram)	DHW temperature B3/B38 (7750)	in °C
TWIN B10 output sensor	BX2 sensor T° (7821)	in °C
B1 flow sensor	Temperature sensor BX21 module 1 (7830)	in °C

	Line No.	Value
B12 flow sensor	Temperature sensor BX21 module 2 (7832)	in °C
B14 flow sensor	Temperature sensor BX21 module 3 (7834)	in °C
VX212 diagram only:		
Check the status of contact H1	Status of contact H1 (7841)	Closed if the shunt is in place
• <u>Configuration</u> menu		
Check the hydraulic diagram	Generator 1 inspection No. (6212)	14
	Generator 2 inspection No. (6213)	0
	DHW information (6215)	0 (VX202 diagram) 4 (VX212 diagram)
	Information about heating circuits 3, 2 and 1 (6217)	30303
On generator No. 2		
• <u>Inputs/outputs test</u> menu		
Check the outputs		
Alarm relay	Relay test (7700)	Relay output QX1
Isolating valve Q1.2	Relay test (7700)	Relay output QX3
Reset the outputs	Relay test (7700)	No test
Check the sensor values (if 4th heating circuit present)		
B1.2 flow sensor	Temperature sensor BX21 module 1 (7830)	in °C
• <u>Configuration</u> menu		
Check the hydraulic diagram	Generator 1 inspection No. (6212)	14
	Generator 2 inspection No. (6213)	0
	DHW information (6215)	0
	Information about heating circuits 3, 2 and 1 (6217)	3 (if 4th heating circuit present)

F. CONFIGURATION OPTIMISATION

On generators 1 and 2

Heating circuit optimisation

• Heating circuit 1 / 2 / 3 menu

Adjust the reduced setting	Reduced setting temperature (712/1012/1312)	---
----------------------------	---	-----

	<i>Line No.</i>	<i>Value</i>
• <u>Heating circuit 1 / 2 / 3 timer programme</u> menu		
Preselection	Preselection (500/520/540)	---
Adjust the timer programming	On / off phases (501...506) (521...526) (541...546)	---
• <u>Heating circuit 1 / 2 / 3 holiday</u> menu		
Preselection	Preselection (641/651/661)	---
Adjust the timer programming	On / off phases (642--643) (652-653) (662-663)	---
Switch the heating regime to automatic		Auto

DHW optimisation:

• <u>DHW tank</u> menu		
Adjust the over value	Output setting temperature over value (5020)	16 °C

VARMAX TWIN optimisation:

The Varmax Twin may be optimised as necessary using the parameters in the **Flow** menu. Refer to the NAVISTEM B3000 boiler's controller manual for more details.

Maintenance optimisation

A maintenance message may be generated that does not set the generator to fault. This maintenance message may be displayed after the following 3 counters have expired:

- Time since last maintenance (or commissioning): set parameter 7044 to 12 months (**Maintenance / Special regime** menu)
- Burner's operating hours (parameter 7040 - menu **Maintenance / Special regime** menu)
- Number of starts (parameter 7042 - menu **Maintenance / Special regime** menu)

These last 2 parameters are dependent on the boiler's hydraulic installation. We recommend using at least parameter 7044 for annual maintenance.

9. SPARE PARTS LIST

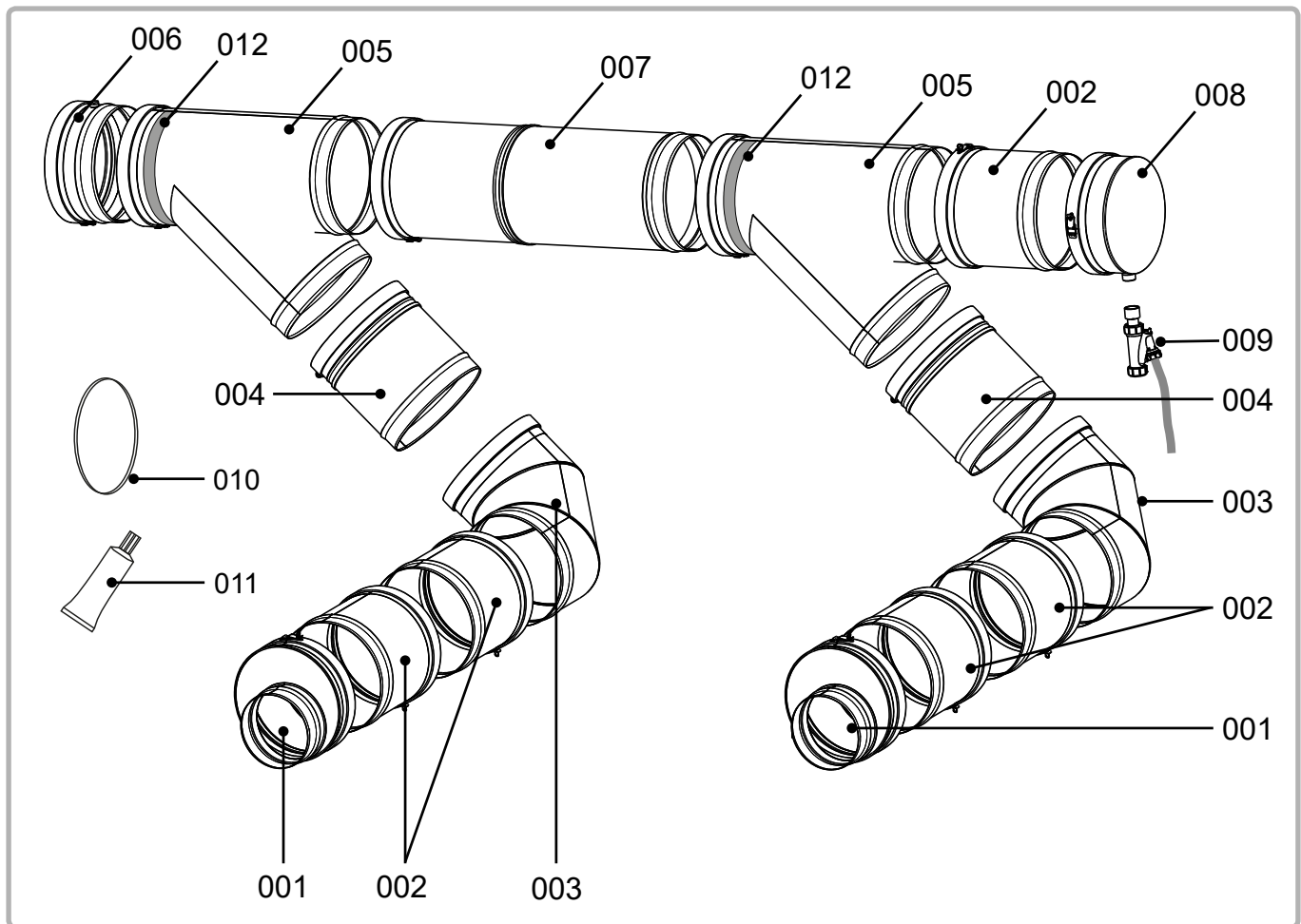

ITEM	DESIGNATION	REF. FOR MODELS			
		550	640	780	900
001	Offset increase with seal and grease	76479		76480	
002	250 mm long straight element with seal and grease	76481		76482	
003	90° curved element with seal and grease	76483		76484	
004	260-400 mm long adjustable element with seal and grease	76485		76486	
005	135° T with seal and grease	76487		76488	
006	Measuring element with seal and grease	76489		76490	
007	550 - 900 mm long adjustable element with seal and grease	76491		76492	
008	Side drain buffer with seal and grease	76493		76494	
009	Siphon	76477			
010	Set of 5 seals with grease	76495		76496	
011	30 ml tube of silicon grease	76478			
012	Suspension collar for flue support	76497		76498	
--	OCI 345 communication module	76168			
--	LPB bus cable	76452			
--	QAZ 36 sensor	62864			
--	Set of 2 LPB bus cable trays with screws	76453			
--	Set of 4 Teflon plates	76454			



Hamworthy Heating Accredited Agents

North West England (Sales & Service)

Gillies Modular Services

210-218 New Chester Road, Birkenhead, Merseyside L41 9BG

tel: 0151 666 1030 fax: 0151 647 8101

Scotland (Sales & Service)

McDowall Modular Services

14-46 Lomond Street, Glasgow, Scotland G22 6JD

tel: 0141 336 8795 fax: 0141 336 8954

Southern Ireland (Sales & Service)

HEVAC Limited

Naas Road, Dublin 12, Ireland

tel: 00 353 141 91919 fax: 00 353 145 84806

North East England (Service)

Allison Heating Products

12 Sunnyside Lane, Cleadon Village, Sunderland SR6 7XB

tel: 0191 536 8833 fax: 0191 536 9933

Northern Ireland (Sales & Service)

HVAC Supplies Limited

Unit A6, Dargan Court, Dargan Crescent, Belfast BT3 9JP

tel: 02890 747737 fax: 02890 741233

Hamworthy Heating Customer Service Centre

Sales

tel: 0845 450 2865

Technical Enquiries

tel: 0845 450 2865

Servicing

tel: 01202 662555

Spares

tel: 0845 450 2866



Customer Service Centre

Hamworthy Heating Limited,

Fleets Corner, Poole,

Dorset BH17 0HH.

Telephone: 0845 450 2866

Fax: 01202 662522

Email: aftersales@hamworthy-heating.com

Website: www.hamworthy-heating.com