

# Prestige Trimax 175 Ignition Kit - Installation Instructions

## 1.1. Applicability

Prestige boilers with "PT"-prefixed serial number, as indicated on data plate.

Kit Part Number	Model
PTRKIT302	PT 175

Table 1 - PT Ignition Kit Numbers

## 1.2. Purpose

This kit (see *Fig. 3* for details) replaces the existing TriMax control module, the igniter and wiring, the internal venting tube and the heat exchanger insulation.

## 1.3. Initial tasks

Confirm the replacement kit is appropriate for the boiler to be worked on (see *Table 1*).

Write down all the appliance settings, including the cascade settings (if the boiler is in a cascade) for reference before bringing any change to the appliance. A reference table is provided on the last page of this document.

## 1.4. Boiler preparation

### 1.4.1 Required Tools and Material

- Screwdriver, flat head
- Screwdriver, cross head
- 10 mm socket/wrench
- Wrench, Torx 20
- Flue gas analyzer

### 1.4.2 Preparation Procedure

1. Turn the boiler off by pressing the on/off power switch.
2. Allow boiler to cool down.
3. Disconnect electrical power at the external electric box



- **Avoid electrical shock by disconnecting the electrical supply prior to performing any operation on the internal parts of the boiler.**



- **Before any operation on the internal components of the appliance, allow the appliance to cool down to room temperature. Some components can be very hot.**
  - **Failure to comply will result in substantial property damage, serious injury, or death.**
4. Shut off the gas supply to the boiler at the main manual shut off valve.
  5. Remove boiler front panel as follows:
    - Remove the thumb screw along the upper edge of the unit.
    - Lift the panel up and tilt back slightly to remove the front panel.
  6. Slide left and right tabs of control panel inward and lower control panel. See *Fig. 1*.

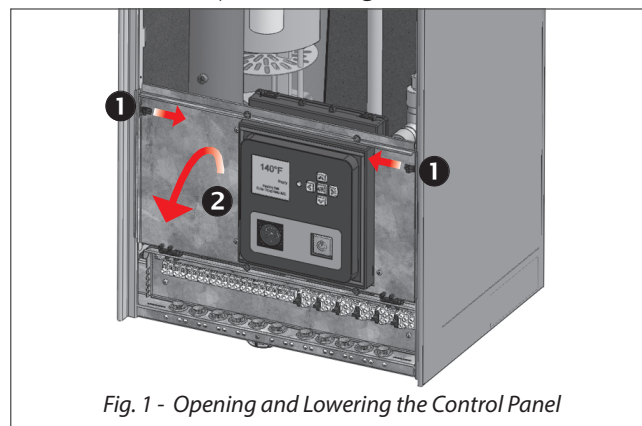

Fig. 1 - Opening and Lowering the Control Panel

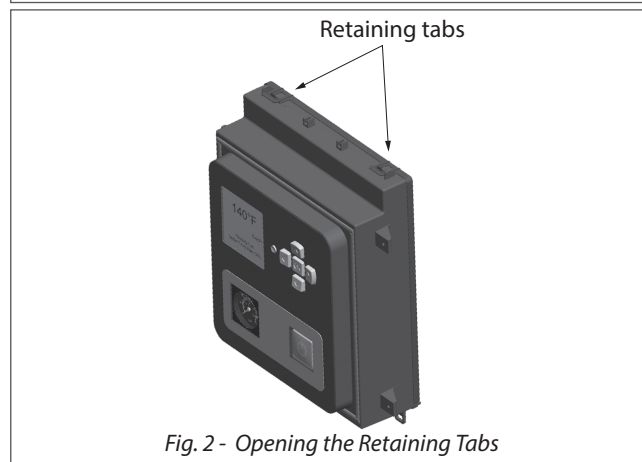

Fig. 2 - Opening the Retaining Tabs

# PRESTIGE IGNITION KIT - INSTALLATION INSTRUCTIONS

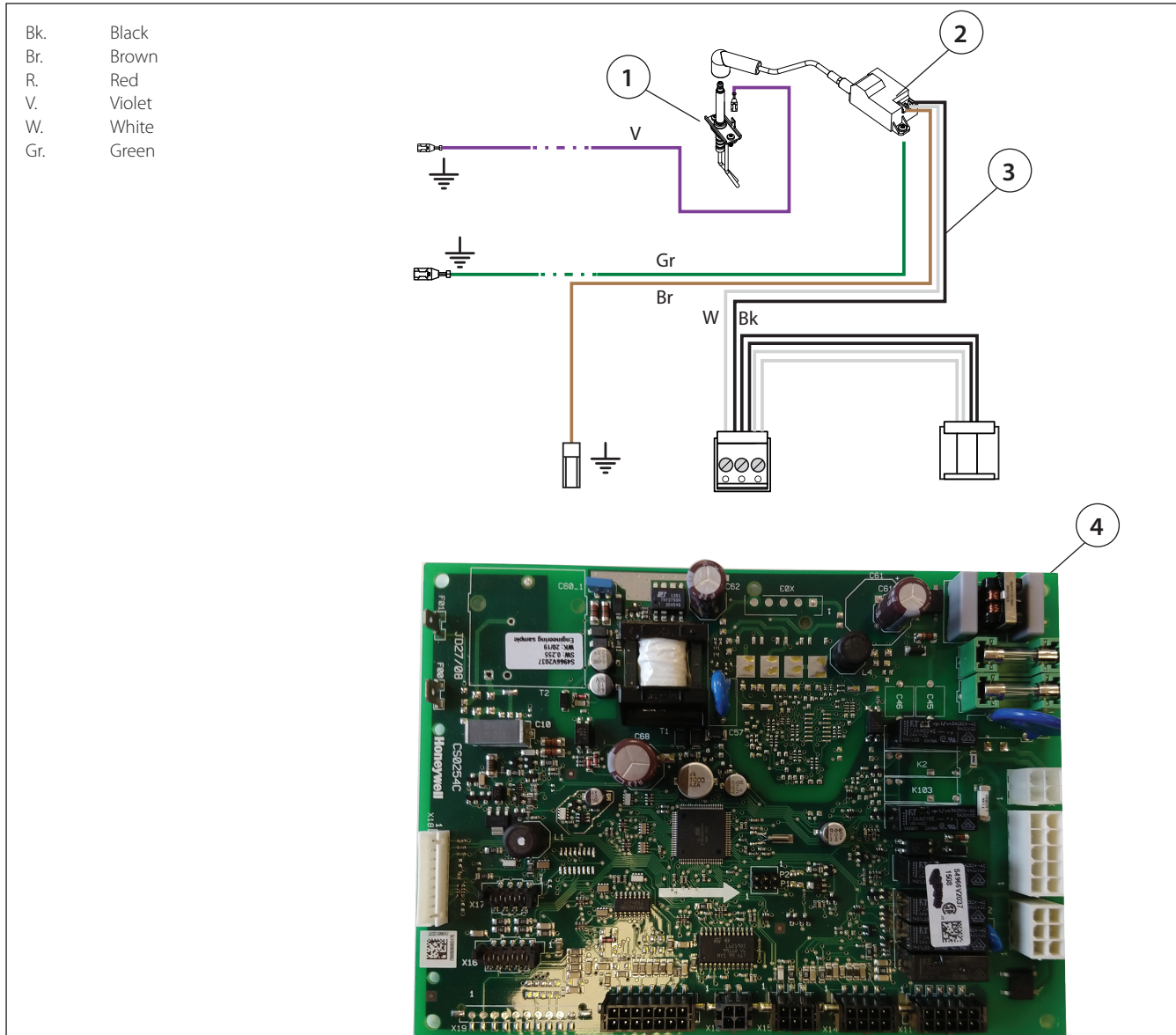

Fig. 3 - Prestige Solo & Excellence - Ignition Kit

Item	Description	Qty
	Igniter	1
1	Screws, igniter	2
	Gasket, igniter	1
	Bracket, spark generator (not illustrated)	1
2	Spark generator	1
3	Wiring, spark generator	1
4	Control Module, TriMax	1
	Burner insulation (not illustrated)	1
	"PU" Sticker, S/N adaptation (not illustrated)	1

## PRESTIGE IGNITION KIT - INSTALLATION INSTRUCTIONS

### NOTICE

*Before disconnecting any wire connections, mark and label all connections and location of the connections.*

7. Pull the retaining tabs on top of the rear cover to remove the rear control box cover. See *Fig. 2*.
8. Disconnect the ignition cable by grasping the ignition terminal and pulling firmly upwards from the back of the control module.
9. Remove all (8) Molex wiring connectors from the Control Module.
10. Support TriMax Control Module with one hand while removing individual Molex connectors, pressing tabs on Molex plugs for quick release. See *Fig. 4 below*.

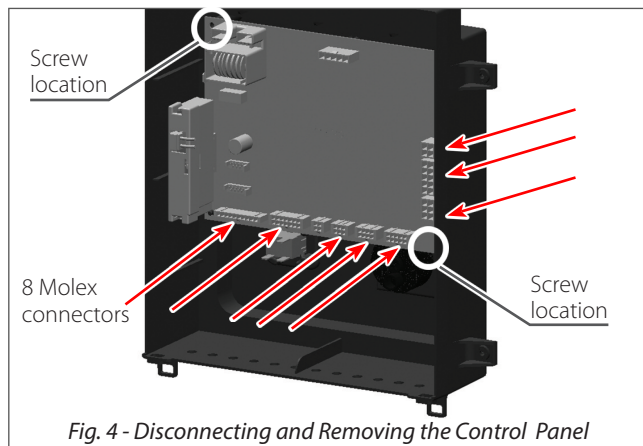

*Fig. 4 - Disconnecting and Removing the Control Panel*

### 1.5. Burner Insulation and Igniter Replacement

#### 1.5.1 Required Tools and Material

- Flat head screwdriver
- Extended Phillips/Torx head screwdriver
- Torx wrench
- Cord saw or similar tool to cut venting pipe

#### 1.5.2 Removal of Internal components

1. See *Fig. 5* for reference. Remove air intake (3) from venturi. Retain for reinstallation.

### NOTICE

*Before disconnecting any wire connections, mark and label all connections and location of the connections.*

2. Open top access panels by removing top access panel (1) located above the heat exchanger on the top jacket panel.

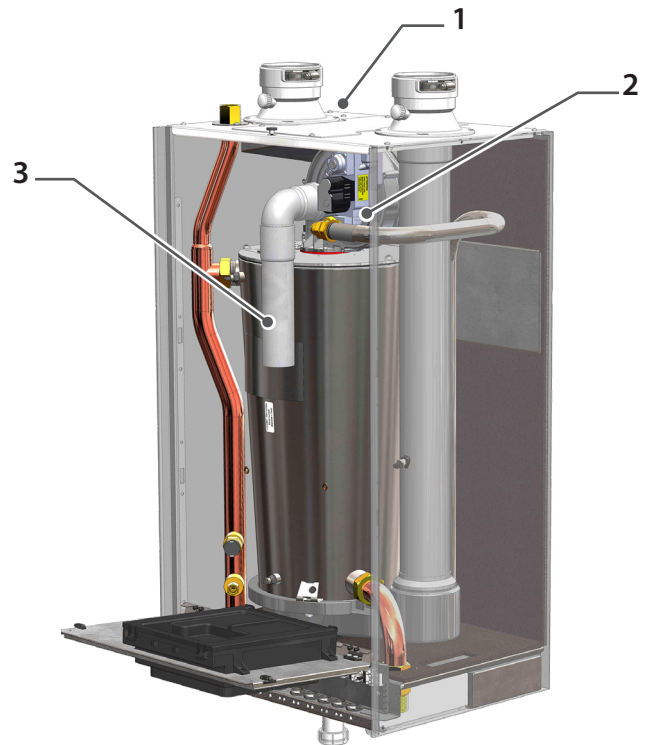

*Fig. 5 - Boiler Components*

3. Disconnect all connectors from the blower and the gas valve.
4. Using 2 wrenches, disconnect the gas supply piping (2) inside the boiler at the brass union located just below the gas valve. The gas piping can remain inside the boiler or be removed for additional clearance / access.
5. Holding the gas valve/venturi assembly with one hand, release the mounting screws that secure the venturi to the blower.
6. Remove the gas valve/venturi assembly and hardware from the blower. Retain for reinstallation.

#### 1.5.3 Checking the Orifice Size

1. Remove 3 screws securing the gas valve to the venturi and check the presence of an orifice and its size, if any.
2. Make sure that the correct orifice (see *Table 2*, if any is required, is installed on the boiler. Replace or install one as required.
3. Reassemble gas valve and venturi and set assembly aside for later reinstallation.

## PRESTIGE IGNITION KIT - INSTALLATION INSTRUCTIONS

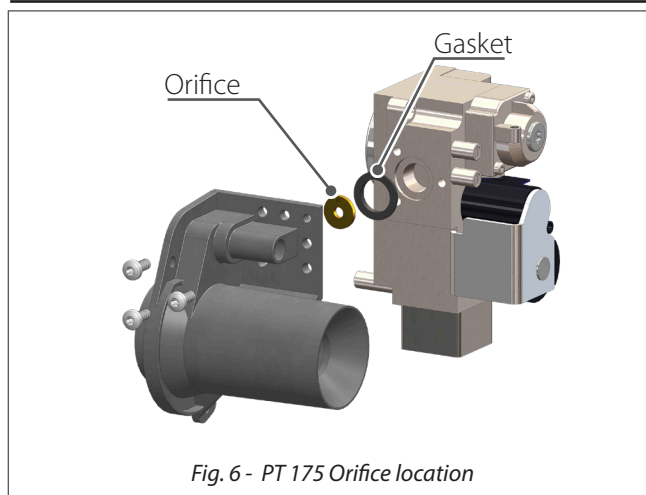

Fig. 6 - PT 175 Orifice location

PT version	NG	LP
175	None Required	0.221" – 5.6mm

Table 2 - Orifice Sizes

### 1.5.4 Removing the Burner and Insulation

1. Remove heat exchanger bracket located at the back of the heat exchanger. Discard bracket.
2. Remove burner plate nuts securing the burner mounting plate to the heat exchanger using a socket wrench.
3. Remove burner plate/burner and blower by release 4 screws securing the blower to the burner plate. Retain for later reinstallation. Then remove blower from burner plate.
4. Remove insulation from burner. Discard according to applicable local regulations.
5. Disconnect the igniter wiring from the igniter. Discard.
6. Using the Torx wrench, release two screws and remove the igniter and gasket from the burner mounting plate. Discard all.

#### **NOTICE**

*If the gasket is stuck on the igniter support, use a flat head tool and release it carefully from the surface. Be careful not to scratch the surface.*

7. Clean combustion chamber. Refer to the installation manual of the appliance.

### 1.5.5 Installation of new Insulation and Burner

1. Slide the newly supplied burner insulation over the existing burner tube.
2. Install the new igniter (See Fig. 7), with its new gasket, on the burner mounting plate support, paying attention not to damage the new insulation.

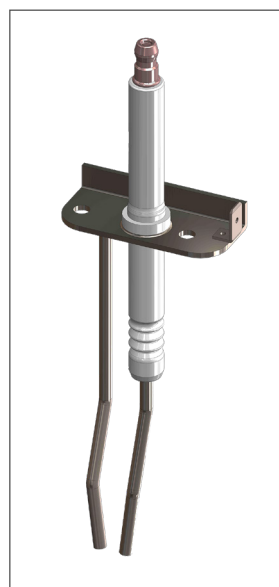

Fig. 7 - Prestige Trimax - New Igniter

3. Tighten 2 igniter screws by hand, then torque screws between 13 and 18 lbf-in.

#### **NOTICE**

*Do not exceed the recommended max. torque value for the igniter attachment screws to prevent the igniter stems from distorting.*

4. Place burner/burner plate/insulation assembly carefully in position. Do not secure the assembly just yet.
5. If removed previously, reinstall the blower and gasket.
6. Secure burner plate using the retained nuts. Torque at 50 lbf-in.
7. Reinstall the venturi/gas valve assembly on blower using retained screws.
8. Reconnect the gas pipe to the gas valve connection.

### 1.5.6 Installation of Spark Generator

1. Install spark generator on bracket using 2 screws.
2. Locate the spark generator with bracket (A) on the blower (B). (See Fig. 9), and secure using 2 of the venturi-to-blower screws.
3. Connect the spark generator cable with connector (C) to the new igniter.

## PRESTIGE IGNITION KIT - INSTALLATION INSTRUCTIONS

### 1.5.7 Control Module Replacement

1. Remove the 2 screws securing the Control Module into the enclosure and remove the Control Module. Retain screws for new Control Module installation. See **Fig. 4**.
2. Discard Control Module according to applicable local regulations.
3. Install new TriMax control module with 2 retained screws.
4. Reinstall the rear cover of the control module.

### 1.5.8 Wiring Connection (See Fig. 12)

1. Reconnect all disconnected plugs to blower, gas valve and sensors, as required.
2. Reconnect light green grounding cable (disconnected from old igniter) to the gas valve grounding tab.
3. Connect new brown cable to ignition transformer and to control module grounding tab F01. See **Fig. 12**.
4. Connect new violet wire to igniter grounding tab and to control module grounding tab F00.
5. Reconnect all disconnected Molex wiring connectors to the Control module, except X02.
6. Connect spark generator wiring to the control module and to unconnected Molex connector.
7. Connect new green grounding wire to one of the left grounding tabs on the casing.
8. Connect green grounding cable that used to be connected to F00 to the grounding tab on the new violet cable connection.

### 1.5.9 Checking the Combustion Settings

1. Turn boiler on.
2. Allow the appliance to stabilize and insert the gas analyzer probe in the top vent adapter measuring port.
3. Check combustion values as follows (please reference the Installation Manual of the appliance for more details on the controls):
  - Press the round INSTALLER button.
  - Enter the installer access code "054" by using the LEFT and RIGHT buttons to select a digit and the UP and DOWN buttons to change the digit. Press the OK button to confirm.
  - Using the RIGHT button, highlight the Manual Operation icon, then press the OK button.
  - Press the OK button while the FAN icon is highlighted to manually fire the burner and power the CH circulator.
  - Press the RIGHT button to adjust the firing rate from 1% to 100%.

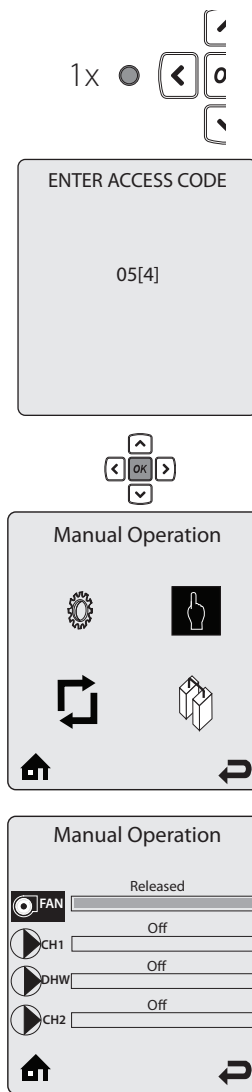

**Fig. 8 - Accessing the Combustion Adjustment Interface**

- If the CO<sub>2</sub> level during high fire (100%) differs by more than 0.4% from the recommended combustion setting (See **Table 3**) adjust the throttle screw (see **Fig. 10**) as follows:
  - Counter-clockwise rotation of the throttle screw at High Fire : O<sub>2</sub> decreases, CO<sub>2</sub> increases
  - Clockwise rotation of the throttle screw at High Fire : O<sub>2</sub> increases, CO<sub>2</sub> decreases.
- Once the combustion level is set at high fire (100%), manually place the boiler into low fire (1%) mode by pressing the LEFT button to adjust firing rate down.

# PRESTIGE IGNITION KIT - INSTALLATION INSTRUCTIONS

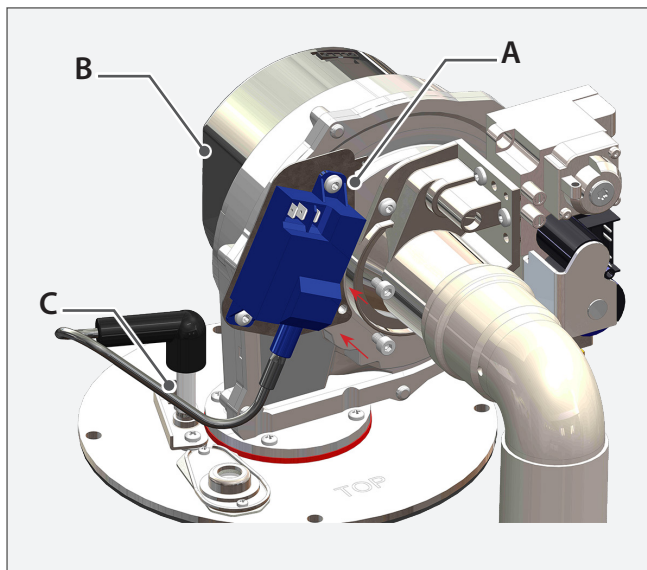

Fig. 9 - Spark Generator and Bracket (PT 175)

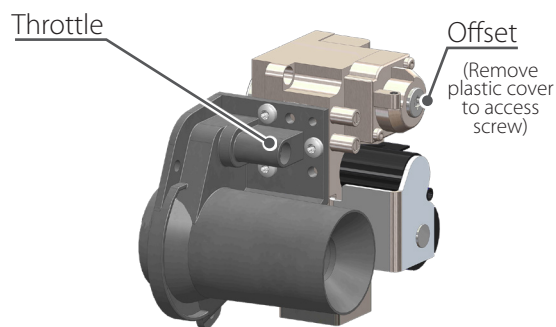

Fig. 10 - Throttle and Offset Locations

		NG	LP
High Fire	CO <sub>2</sub>	9.5%	11.2%
	O <sub>2</sub>	4.0%	4.0%
	CO	< 100 ppm	<100 ppm
Low Fire	CO <sub>2</sub>	9.5%	11.2%
	O <sub>2</sub>	4.0%	4.0%

Table 3 - Recommended Combustion Levels

- If the CO<sub>2</sub> combustion level during low fire (1%) differs by more than 0.4% from the recommended combustion setting (See **Table 3**), remove plastic cover from Offset screw (See **Fig. 10**) and adjust as follows:
  - Counter-clockwise adjustment of the offset screw at Low Fire : O<sub>2</sub> increases, CO<sub>2</sub> decreases
  - Clockwise adjustment of the offset screw at Low Fire : O<sub>2</sub> decreases, CO<sub>2</sub> increases.

## 1.5.10 Return to Service

1. Reinstall the air intake on the venturi.
2. Close top access panel, as required.
3. Check that all wiring connections are secure.
4. Check that the gas connection is tight.
5. Supply power to the boiler through the external electric box.
6. Open gas supply.
7. Turn boiler on using the boiler On/Off switch.
8. Perform any required configuration change in the Tri-Max setup according to the initial settings indicated in **"Default Values and Adjustments"** on page 8.
9. Reinstall the boiler front panel.
10. On the rating plate of the appliance, install the sticker provided with the kit. This will indicate that the boiler has been upgraded with the ignition kit, for future reference.

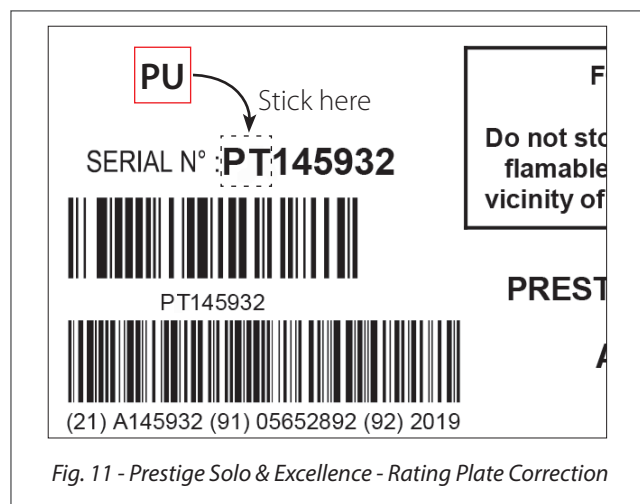
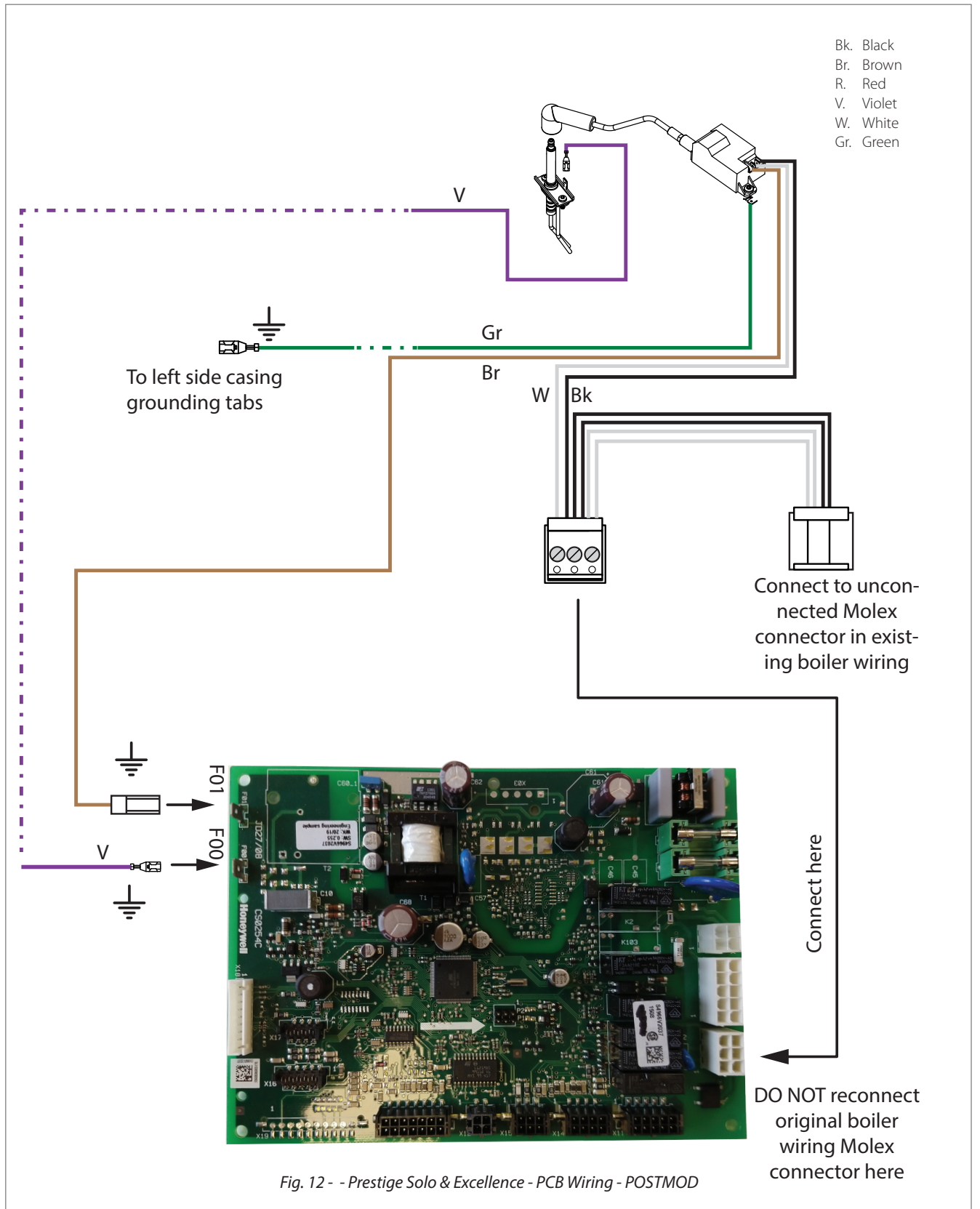

Fig. 11 - Prestige Solo & Excellence - Rating Plate Correction

# PRESTIGE IGNITION KIT - INSTALLATION INSTRUCTIONS



# PRESTIGE IGNITION KIT - INSTALLATION INSTRUCTIONS

## 1.6. Default Values and Adjustments

HEATING SETTING	FACTORY DEFAULT	MINIMUM SETTING	MAXIMUM SETTING	EXISTING SETTING
Heating Operation	Enabled			
Demand	Switch & Outdoor Reset			
Absolute Max CH Setpoint	188°F [87°C]	68°F [20°C]	188°F [87°C]	
CH1 Maximum Setpoint	180°F [82°C]	68°F [20°C]	188°F [87°C]	
CH1 Minimum Setpoint	120°F [49°C]	60°F [15°C]	188°F [87°C]	
Reset Curve Coldest Day	0°F [-18°C]	-30°F [-34°C]	50°F [10°C]	
Reset Curve Warmest Day	64°F [18°C]	60°F [15°C]	78°F [25°C]	
CH2 Circuit	Enabled			
CH2 Maximum Setpoint	140°F [60°C]	68°F [20°C]	188°F [87°C]	
CH2 Minimum Setpoint	80°F [27°C]	60°F [15°C]	188°F [87°C]	
Warm Weather Shutdown	OFF	OFF	78°F [25°C]	
Pump Constant Circulation	Disabled			
CH Post Pump Time	1 minute	OFF	20 minute	
Freeze Protection	Enabled			
Frost Protection Setpoint	-22°F [-30°C]	-22°F [-30°C]	50°F [10°C]	
Parallel Shift Value	0°F [0°C]	0°F [0°C]	144°F [80°C]	
CH Call Blocking	1 minute	0 minute	30 minutes	
System Pump	CH1/CH2			

DOMESTIC SETTING	FACTORY DEFAULT	MINIMUM SETTING	MAXIMUM SETTING	EXISTING SETTING
DHW Operation	Enabled			
Demand	Switch			
Boiler DHW Setpoint	186°F [86°C]	96°F [35°C]	188°F [87°C]	
DHW Storage Setpoint	140°F [60°C]	68°F [20°C]	150°F [65°C]	
DHW On Differential	6°F [3°C]	4°F [2°C]	18°F [10°C]	
DHW Storage Adder	46°F [25°C]	0°F [0°C]	54°F [30°C]	
DHW Post Pump Time	1 minute	OFF	30 minutes	
DHW Priority Timeout	OFF	OFF	120 minutes	
DHW Priority	Enabled			
DHW Call Blocking	0 minute	0 minute	30 minutes	
DHW to CH Call Blocking	1 minute	0 minute	30 minutes	
Antilegionella Function	Disabled			

BOILER SETTING	FACTORY DEFAULT	MINIMUM SETTING	MAXIMUM SETTING	EXISTING SETTING
Prestige Model	Solo			
Lockout Temperature	210°F [99°C]			
Modbus Address	0=BCST	0	247	

CASCADE SETTING	FACTORY DEFAULT	MINIMUM SETTING	MAXIMUM SETTING	EXISTING SETTING
Stage Delay	60 seconds	0 second	255 seconds	
Minimum Firing Rate	30%	0%	100%	
Maximum Firing Rate	398 MBH [117kW]	0 MBH [0kW]	869 MBH [255kW]	
CH / DHW Boilers	0	0	6	
Automatic Rotation	Enabled			
CH Proportional Gain	7	1	255	
CH Integral Gain	245	1	255	
DHW Proportional Gain	7	1	255	
DHW Integral Gain	245	1	255	