

# **Cranborne THI 5-25c Wall Hung Gas Fired Condensing Boiler Room Sealed or Open Flue**

## **INSTALLATION, COMMISSIONING AND SERVICING INSTRUCTIONS**

**IMPORTANT NOTE: THESE INSTRUCTIONS MUST BE READ AND UNDERSTOOD BEFORE INSTALLING, COMMISSIONING, OPERATING OR SERVICING THIS APPLIANCE.**

**THE CRANBORNE THI 5-25c BOILER IS INTENDED FOR USE AS A DOMESTIC / LIGHT COMMERCIAL APPLIANCE FOR HEATING AND DOMESTIC HOT WATER INSTALLATIONS.**

**THIS BOILER IS FOR USE ON GROUP H NATURAL GAS (2<sup>ND</sup> FAMILY) I<sub>2H</sub>. PLEASE ENSURE RELEVANT INFORMATION REQUIRED WITHIN DOCUMENT IS FOUND RELATING TO SPECIFIC GAS TO BE FIRED BEFORE FIRING BOILER.**

THIS BOILER COMPLIES WITH ALL RELEVANT EUROPEAN DIRECTIVES  
EC IDENTIFICATION No. CE-0085AQ0543

PUBLICATION NO. 500001116  
ISSUE 'B'  
AUGUST 2003

# CONTENTS

<b>I - PRESENTATION .....</b>	<b>5</b>
1 - DESCRIPTION .....	5
<b>II - TECHNICAL SPECIFICATIONS .....</b>	<b>6</b>
1 - CHARACTERISTICS .....	6
2 - PIPE CONNECTION DIAMETERS.....	7
3 - DIMENSIONS .....	8
3.1 - THI 5-25 C .....	8
4 - LIST OF COMPONENTS.....	10
4.1 - THI 5-25 C .....	10
4.6 - Control panel .....	15
5 - MODULATING PUMP CHARACTERISTICS.....	16
6 - PRESSURE DROP IN THE BOILER (HEATING CIRCUIT).....	17
7 - EXPANSION VESSEL CHARACTERISTICS .....	17
8 - THERMAL EFFICIENCY .....	18
<b>III - OPERATION .....</b>	<b>19</b>
1 - GENERAL OPERATING PRINCIPLE.....	19
2 - OPERATION OF THE LMU MANAGEMENT UNIT .....	20
2.1 - Normal operating conditions .....	20
2.2 - Operating diagram .....	20
2.3 - Principle of air/gas servo-control system .....	22
2.4 - Air pressure variation procedure .....	22
2.5 - Emission of pollutants .....	22
3 - FUNCTIONS.....	23
3.1 - Anti-freeze function .....	23
3.2 - Anti-legionella function .....	23
3.3 - Pump run-on after the end of heating .....	23
3.4 - Pump kick or selector valve kick .....	23
3.5 - Boiler overheat protection .....	23
3.6 - Monitoring of flue gas temperature .....	24
3.7 - Boiler return temperature control .....	24
3.8 - Monitoring of hydraulic pressure .....	24
3.9 - Anti-short burner cycle protection function .....	24
3.10 - Cleaning function .....	24
3.11 - Regulator shutdown function .....	24
3.12 - LMU programmable key .....	25
3.13 - Automatic summer/winter switching (only activated with outside sensor) .....	25
4 - DIFFERENT VERSIONS OF THE THI .....	26
4.1 - THI basic model (without outside sensor, without room sensor) .....	26
4.2 - THI with outside sensor only .....	26
4.3 - THI with outside and room sensors .....	29

<b>IV - INSTALLATION .....</b>	<b>30</b>
1 - GENERAL.....	30
2 - VENTILATION .....	31
2.1 - THI models with conventional flue connection .....	31
2.2 - THI models with balanced flue connection .....	31
3 - COMBUSTION PRODUCT FLUEING .....	32
3.1 - Conventional flue outlets (B23 model) .....	32
3.2 - Balanced flue outlet .....	33
4 - SUPPORT BRACKET.....	40
5 - HYDRAULIC CONNECTION .....	41
5.1 - Recommendations .....	41
5.2 - Accessories to connect, install or adjust .....	41
5.3 - Under-floor heating recommendations .....	42
5.4 - Heat exchanger flow rate .....	42
5.5 - Hydraulic connection for model THI 5-25 C .....	43
5.6 - Hydraulic connection for models THI C+ DHW production system of type BS .....	43
6 - GAS CONNECTION .....	46
7 - ELECTRICAL CONNECTION.....	46
7.1 - Mains connection .....	46
7.2 - Connection of the sensors to the LMU management unit .....	46
7.3 - Under-floor heating safety .....	46
7.4 - Wiring diagram .....	47
<b>V - SETTINGS OF THE INSTALLATION TYPES .....</b>	<b>48</b>
1 - SINGLE CIRCUIT .....	48
2 - DOUBLE CIRCUIT.....	49
2.1 - Without room sensor .....	50
2.2 - With room sensor .....	50
3 - ACCESS THE SETTINGS VIA THE QAA 73 ROOM SENSOR.....	50
3.1 - Access the lines 51 to 98 .....	50
3.2 - Access the lines 501 to 755 .....	51
<b>VI - COMMISSIONING .....</b>	<b>52</b>
1 - PROTECTION OF THE INSTALLATION.....	52
1.1 - Bionibal .....	52
1.2 - Bionibagel .....	52
2 - FILLING THE INSTALLATION WITH WATER .....	53
3 - PRESSURE SENSOR.....	53
4 - GAS SUPPLY .....	53
6 - SETTING THE MAXIMUM POWER IN HEATING MODE.....	54
7 - VERIFICATIONS PRIOR TO COMMISSIONING .....	54
8 - USER INFORMATION.....	54

9 - COMMISSIONING .....	55
10 - FLAME SETTING .....	56
11 - COMBUSTION PRODUCT CHECKING .....	56
<b>VII - GAS CONVERSION .....</b>	<b>57</b>
1 - SERVICE PRESSURE CONTROL.....	57
3 - GAS/CO2/CO/NOX FLOW CONTROL.....	58
3.1 - Surveillance procedure .....	58
3.2 - Setting table .....	59
<b>VIII - MAINTENANCE .....</b>	<b>60</b>
1 - SERVICING THE FAN AND THE BURNER.....	60
2 - SERVICING THE HEAT EXCHANGER OF THE BOILER SHELL.....	61
4 - CHECKING ACCESSORIES .....	61
5 - EXPANSION VESSEL PRE-INFLATION PRESSURE CHECK .....	61
6 - COMBUSTION PRODUCT CONDUITS .....	62
7 - DRAINING .....	62
8 - SENSOR RESISTANCES .....	62
<b>IX - OPERATING FAULTS .....</b>	<b>63</b>
<b>X - OPTIONS .....</b>	<b>65</b>
1 - REAR WALL SPACER .....	65
3 - SET-UP TAKING ROOM TEMPERATURE INTO ACCOUNT (REG 73) .....	66
4 - LPB COMMUNICATION CLIP-IN KIT (REG 130) .....	66
5 - 2ND HEATING CIRCUIT CLIP-IN KIT .....	66
6 - DOUBLE CIRCUIT KIT (REG 125).....	67
7 - PROGRAMMABLE RELAY CLIP-IN KIT (REG 127).....	67
8 - ZHTI 46 CONTROL UNIT (REG 129).....	67
9 - ZHTI 47 CONTROL UNIT (REG 128).....	68
11 - SELECTOR VALVE KIT FOR CONNECTING THI..C/BS .....	68
<b>XII - NOMENCLATURE .....</b>	<b>71</b>

## 1 - DESCRIPTION

---

**Standard description:** wall mounted condensation boiler for hot water heating, sealed combustion circuit, pre-mixing burner with air-gas supply, and linear power modulation connecting combustion product types B<sub>23</sub>, C<sub>13</sub>, C<sub>33</sub>, following EN 483 (04/00)

The THI boiler is pre-set in the factory for natural gas H (G20).

This boiler comprises all the necessary accessories for the correct working of a water based central heating circuit specifically:

- one boiler comprising:
  - a high performance double walled condensation exchanger,
- a pre-mixing burner, with stainless steel refractory grate,
- a variable speed 230 Volt fan controlled by the regulator,
- a 230 Volt two way gas valve controlled by the air pressure,
- electronic regulation which ensures power modulation depending on the demands for heating or DHW (LMU control unit),
  
- an outside sensor,
- an expansion vessel,
- a modulating pump PWM signal,
- a 3 bar safety-valve,
- a rear wall spacer,

### OPTIONAL:

- Horizontal flue kit (C<sub>13</sub>) allowing the boiler to be connected to a straight horizontal flue.
- Accessories for horizontal connection of the boiler (C<sub>13</sub>) - (extensions, elbows etc.).
- Flue adapter (C<sub>33</sub>) allowing the boiler to be connected to a vertical flue.
- Accessories for vertical connection of the boiler (C<sub>33</sub>) - (terminal, extensions, elbows etc.).
- Adjustment as a function of the room temperature (REG 73).
- 2nd heating circuit kit allowing the connection of a secondary heating circuit (REG 125).
- 2nd heating circuit clip-in allowing the connection of a secondary heating circuit.
- Clip-in LPB communication kit used for cascade or multi-circuit installations (REG 130).
- Clip-in programmable relay kit allowing a secondary pump to work in parallel (REG 127).
  
- Control unit ZHTi 46 (REG 129) controlling an additional heating circuit.
- Control unit ZHTi 47 (REG 128) allowing cascade management for two boilers.
  
- Selector valve kit for connecting THI..C/BS.

# II - TECHNICAL SPECIFICATIONS

## 1 - CHARACTERISTICS

Model				THI	
				5-25 C	
<b>Certification</b>				<b>CE0085AQ0543</b>	
<b>Category / Country of destination: GB</b>				<b>I<sub>2H</sub></b>	
heat output	30/50 °C 60/80 °C	kW kW	5.4/25.8 4.8/23.9		
Heat input		kW	5.0/24.5		
Efficiency Nett	30/50 °C 60/80 °C	% %	108.0/105.3 97.5/96.0		
Efficiency Gross	30/50 °C 60/80 °C	% %	97.2/94.5 87.8/86.5		
Efficiency according to 92/42 CEE directive (30%) load		%	108.5		
Useable gases (NG: Natural gas)				NG H	
Combustion product temperature	maxi	°C	80		
Over-heating safety of combustion products		°C	85		
Flow rate of combustion products	mini/maxi	kg/h	9.0/44.1		
Permitted back pressure (C <sub>13</sub> )	maxi	Pa	100		
Air flow required for combustion		m <sup>3</sup> /h	30		
NO <sub>x</sub>		mg/kWh	< 60		
CO		mg/kWh	< 50		
Heating service pressure	mini/maxi	bar	1/3		
Heating circuit water temperature				80	
Water overheating safety thermostat		°C	100		
Boiler water capacity		litre	2.5		
Primary water flow	60/80 °C	m <sup>3</sup> /h	1.03		
ΔP water (at nominal flow)		mbar	130		
Total capacity of expansion vessel		litre	8		
Useful capacity (with 5m static height)		litre	5		
Thermal losses (ΔT 30 K)		W	79		
Acoustic output at minimum heat output 5,1 kW		dBA	31,2		

Models		THI	
		5-25 C	
Absorbed electrical power in heating mode :			
Control alone		W	min. load: 23 max load: 37
Modulating pump	mini	W	30
	maxi	W	67
Stand By Position		W	9.2
Power supply/frequency		230 V (+ 10%. - 15%)/50 Hz	
Protection factor models B <sub>23</sub> model C <sub>13</sub> /C <sub>33</sub>		IP 24 IP 44	
Weight packaged		kg	63

## 2 - PIPE CONNECTION DIAMETERS

Models		THI	
		5-25 C	
∅ Combustion products	B <sub>23</sub>	mm	125
∅ Combustion products	C <sub>13</sub> C <sub>33</sub>	mm	75/110
		mm	80/125
∅ Gas inlet		inch	1
∅ Heating flow/return		inch	1
∅ Condensation outlet		mm	25
∅ Safety valve outlet		inch	3/4
∅ DHW production system connection (option § 11 - page 68) (* 3/4 with coupling)		inch	1*

### 3 - DIMENSIONS

#### 3.1 - THI 5-25 C

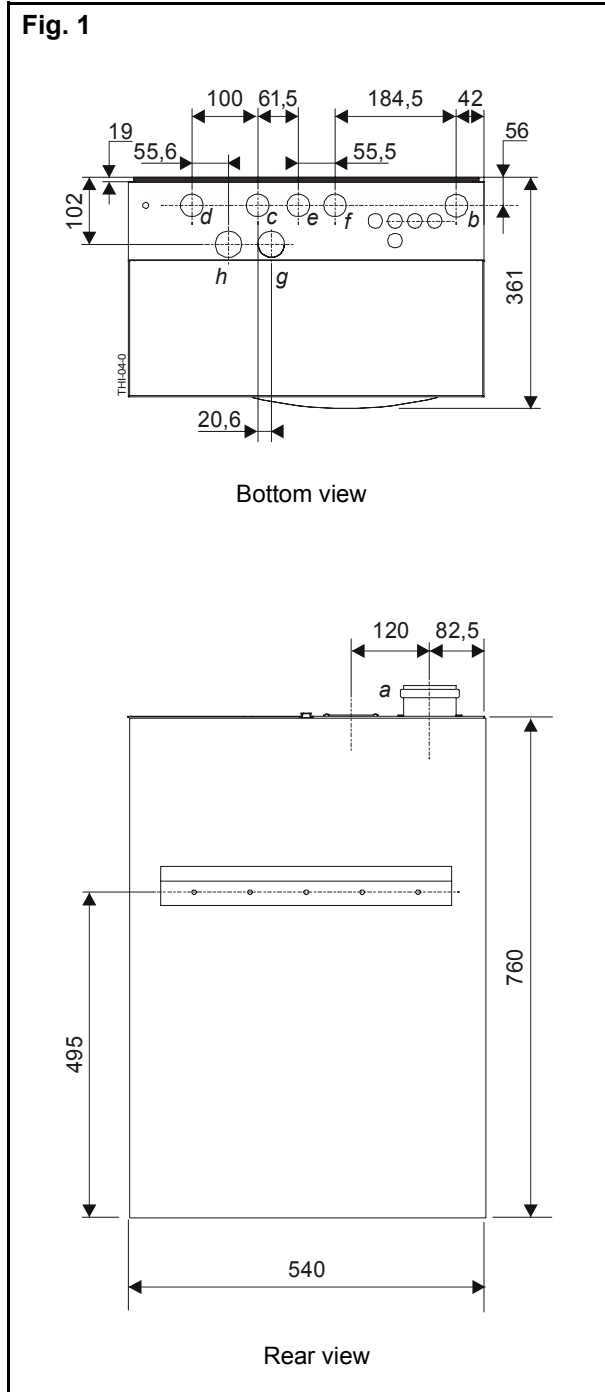

**Legend:**

- a: Combustion products outlet*
- b: Gas inlet*
- c: Heating flow*
- d: Heating return*

- f: Connection DHW production system (option) (THI C)*
- g: Condensate drain*
- h: Safety valve drain*



## 4 - LIST OF COMPONENTS

### 4.1 - THI 5-25 C

Fig. 5

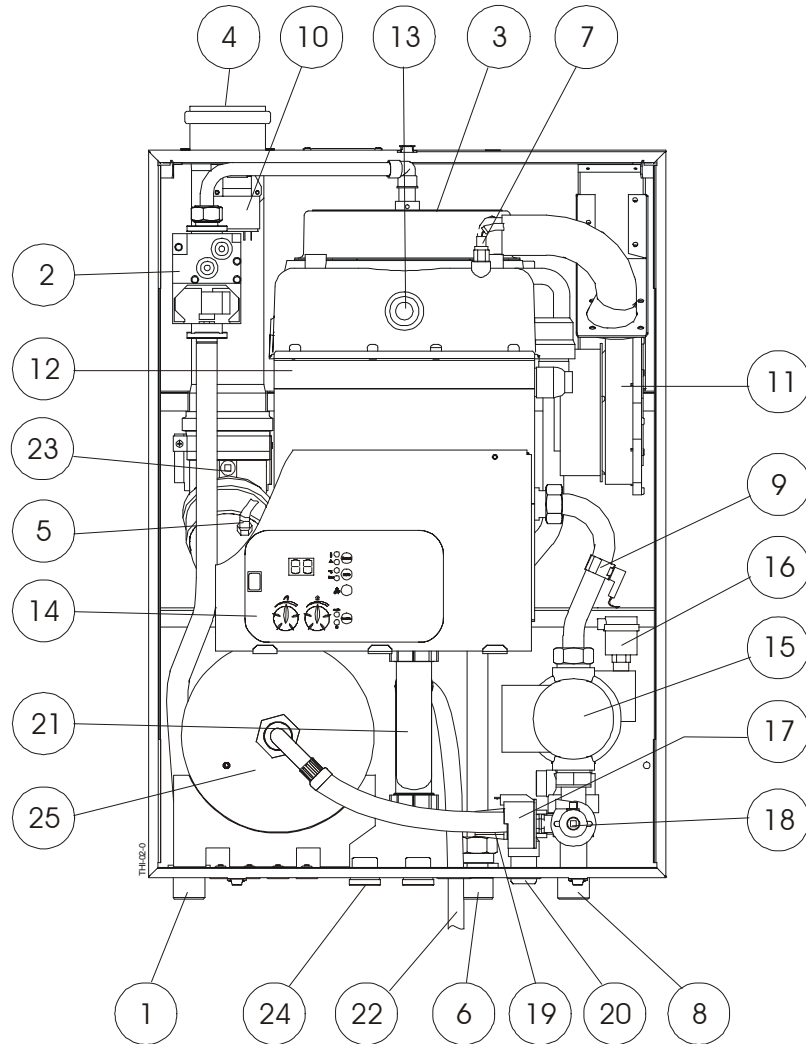

- |   |  |
|---|--|
| 1) Gas inlet                                | 15) 3 speed pump 230 V   |
| 2) Gas unit (solenoids and regulator) 230 V | 16) Air bleed  |
| 3) Gas burner                               | 17) Pressure sensor  |
| 4) Combustion products outlet               | 18) Filter and drain tap   |
| 5) Flue gas sensor                          | 19) Safety valve 3 bar   |
| 6) Heating flow                             | 20) Safety valve outlet  |
| 7) Heating outlet and safety sensor         | 21) Siphon trap  |
| 8) Heating return manifold                  | 22) Condensate drain   |
| 9) Boiler return sensor                     | 23) Combustion check window                                      |
| 10) Ignition transformer 230 V              | 24) Connection for domestic hot water production system (option) |
| 11) Fan 230 V                               | 25) Expansion vessel   |
| 12) Boiler shell                            |  |
| 13) Sight-glass                             |  |
| 14) Microprocessor control panel            |  |

4.6 - Control panel

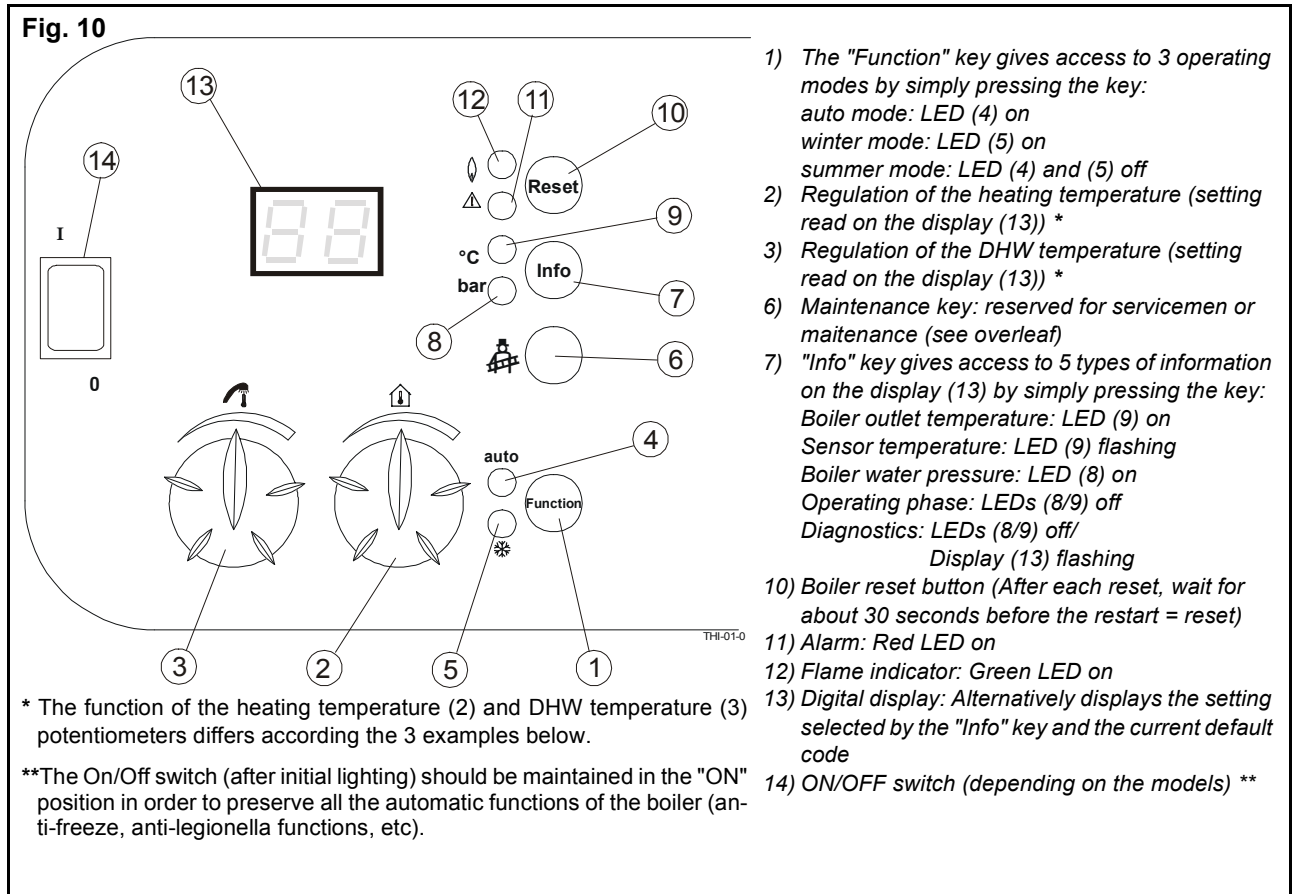

**THI Without room sensor or outside sensor**

The heating (2) and hot water (3) temperatures setting are manually set on the boiler control panel.

- The FUNCTION key (1) gives access to 2 operating modes:
  - Auto mode operation (4): no access
  - Winter mode operation: LED (5) on
  - Summer mode operation: LED (5) off

**THI Without room sensor and with outside sensor**

Possibility of correcting the heating temperature (2) computed automatically using the outside temperature and manual setting of the hot water temperature (3) on the boiler control panel. (The room temperature setting can be changed by + or - 3°C maximum according to the setting).

- The FUNCTION key (1) gives access to 3 operating modes:
  - Auto mode function:  
 auto winter = Leds (4) and (5) on  
 auto summer = Led (4) on + Led (5) off
  - Winter mode operation: LED (5) on
  - Summer mode operation: LEDs (4) and (5) off

**THI With room sensor and outside sensor**

Fitting the QAA73 room sensor cancels the functions of the heating temperature setting (2) and hot water setting (3) on the boiler control panel. All the temperatures required, together with the heating programmes, are set on the QAA 73 (refer to the sensor instructions).

## 5 - MODULATING PUMP CHARACTERISTICS

Advantages :

- Modulation allows a reduction in the electrical consumption of the pump by adapting its flow to the needs of the installation.
- Varying the flow and controlling the return temperature enables the boiler efficiency to be optimized.
- This modulating pump also reduces the noise created by the installation (circulation noise).



**The modulating pump option is only possible with a single heating circuit.**

**The modulation function can be deactivated via the KonfigRg7 parameter.**

It is possible to limit the modulation range via the parameters "NqmodNenn" (Max range) and "NqmodMin" (min. range) (fig. 12).

Action on the "min" allows the equilibrium of the installation to be adapted.

Note:

- A perfectly balanced installation makes for better use of the pump capacities.

Fig. 11

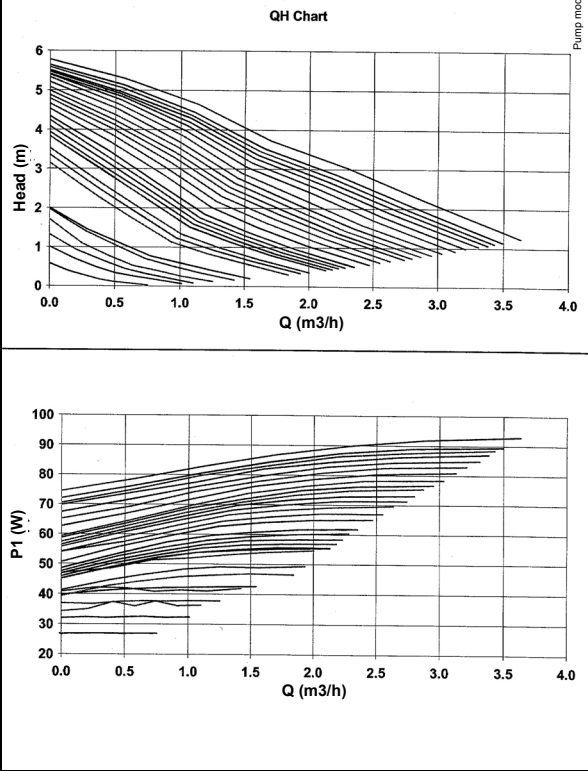
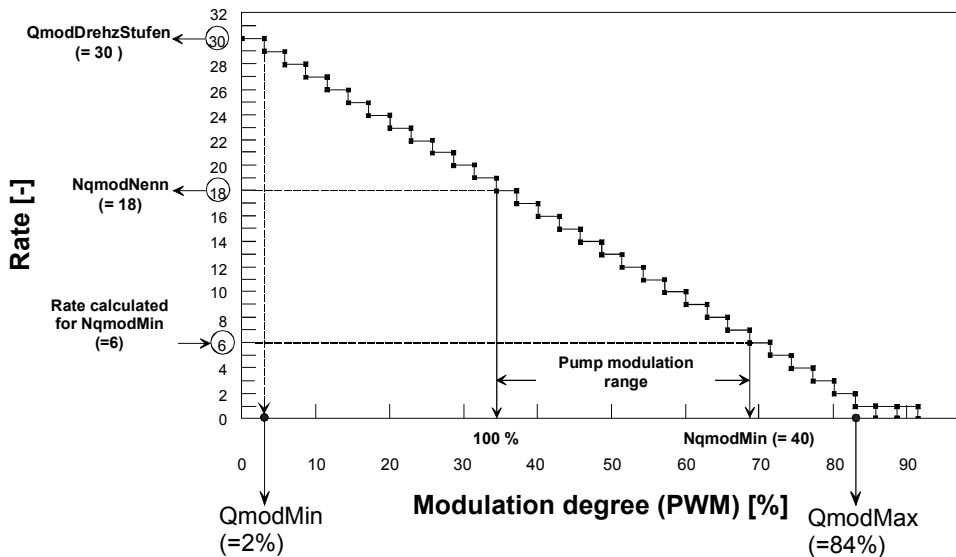
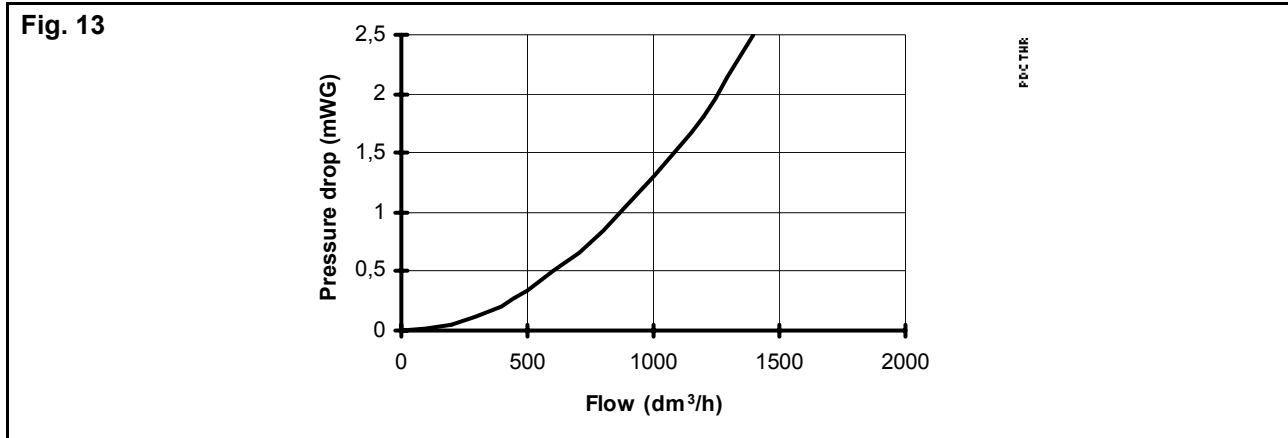

Fig. 12



## 6 - PRESSURE DROP IN THE BOILER (HEATING CIRCUIT)



## 7 - EXPANSION VESSEL CHARACTERISTICS

THI boilers are pre-equipped with an expansion vessel for an installation water capacity of approximately 100 liters.

The expansion vessel absorbs the increase in the water volume in the installation produced by the increase in temperature. The pre-inflation of the vessel sends the internal membrane to the side of the connection and the water dilation pushes on this membrane. Optimum efficiency is obtained when the inflation pressure is equal to the water pressure.

Note:

- The minimum water pressure necessary for the correct working of the installation is defined by the difference in levels between the boiler and the highest point in the installation (e.g. 8 m = 0.8 bar).

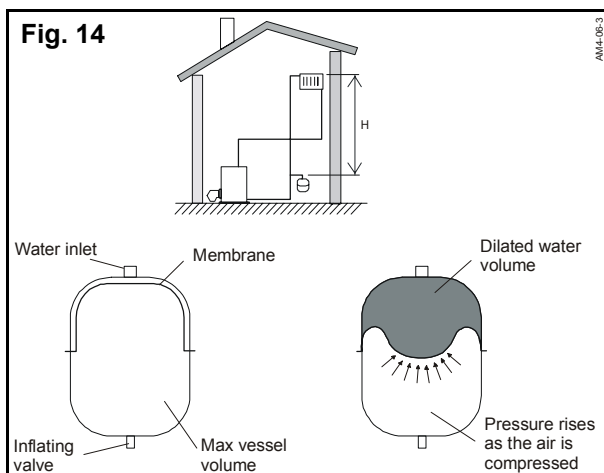

8 - THERMAL EFFICIENCY

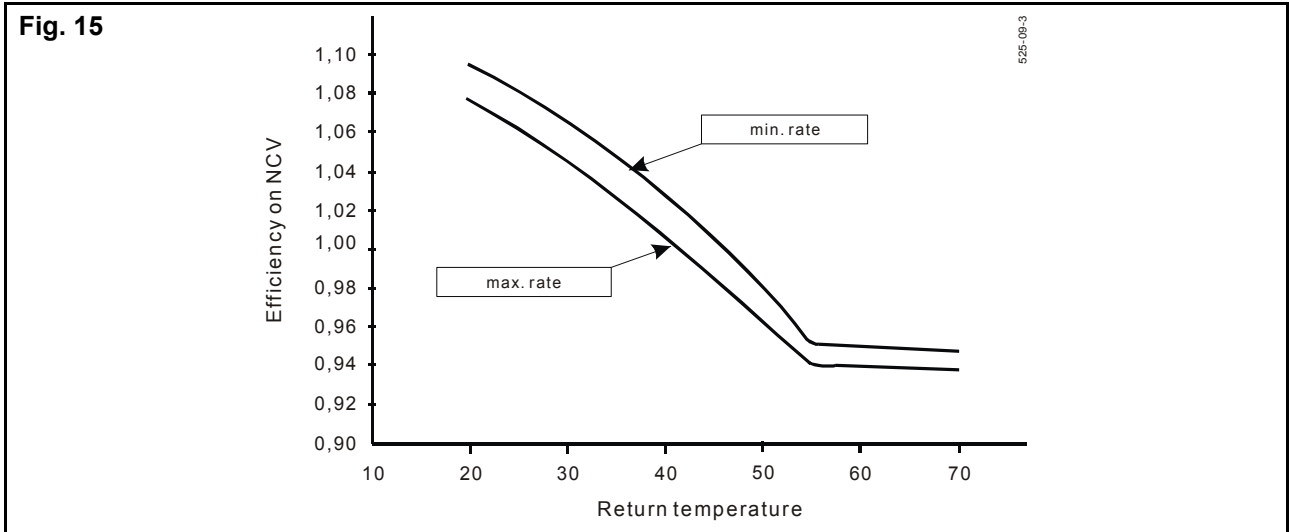

## 1 - GENERAL OPERATING PRINCIPLE

---

The THI boiler is a very high efficiency condensation boiler owing to the burner and heat exchanger that benefit from our longstanding experience.

The over-sized fin tube exchanger and its combustion chamber cooled by water in the upper section, combines the functions of heat exchanger and condenser.

Second generation digital control continuously optimizes the operating rate by using information sent to the microprocessor by the sensors fitted on the boiler:

- boiler flow sensor,
- boiler return sensor,
- outside temperature sensor,
- flue gas temperature sensor,
- room sensor,
- pressure sensor,
- fan speed control (pneumatic air/gas control),
- circulating pump speed control,
- communication bus with external regulators.

Each of the sensors is allocated to an algorithm that optimizes the operation and generates information or fault codes that can be read from the display of the control panel or QAA73 room sensor.

## 2 - OPERATION OF THE LMU MANAGEMENT UNIT

### 2.1 - Normal operating conditions

To access the operating phases of the LMU (display level A4), press the info key (7) three times. The different phases will then be displayed (13).

Note:



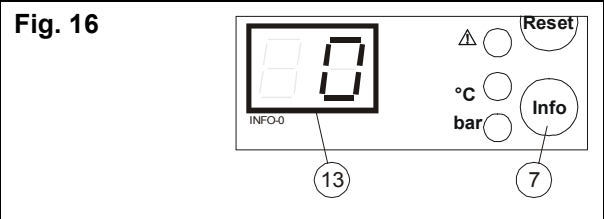





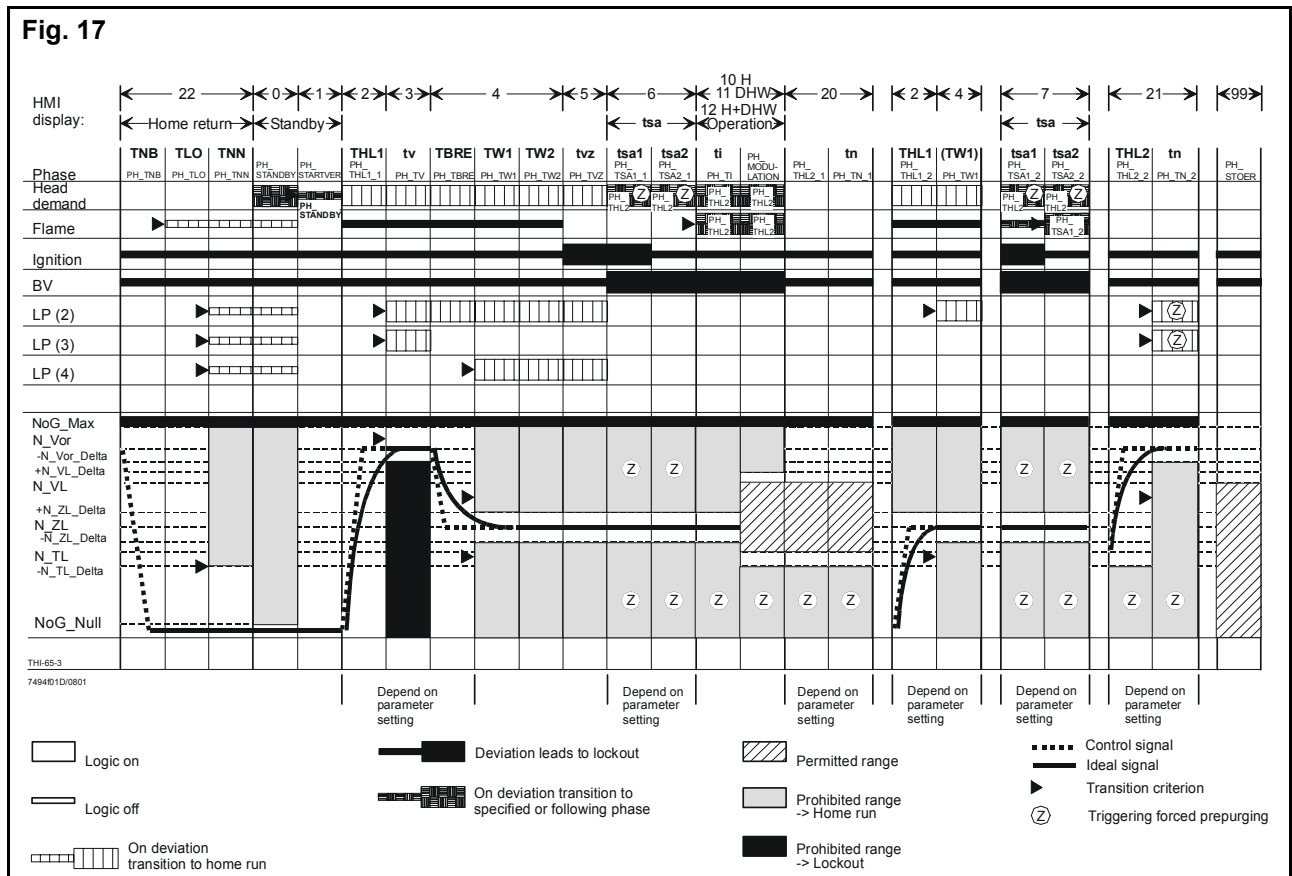





- The phase display will stop automatically after 8 minutes,
- Otherwise, press the info key a 2 times more.



Programming order for normal operating conditions		Programming order for normal operating conditions	
Display	Meaning	Display	Meaning
80	Stand-by (no heating request)	86 87	Ignition - safety time
81	Start-up blocked	10	Heating mode operation
82	Fan speed rise time	11	Hot water mode operation
83	Pre-ventilation time	12	Heating + DHW operation (disabled for THI)
84	Waiting time	20 21	Post-ventilation with last operation command
85	Pre-ignition time	22	Return to initial setting
		99	Fault position (display of current fault code)

### 2.2 - Operating diagram



Explanation of the operating phases		
Display	Phase	Description
<b>Shut down</b>		
	PH_STANDBY (unlimited)	The boiler is on standby and waiting for a heating request.
	PH_STARTVER	Start-up is blocked. The corresponding diagnostic code is emitted (shunt X10-03).
<b>Start-up: heating request</b>		
	PH_THL1_1 (THL1)	Fan speed rise time: - This time ends as soon as the fan motor speed reaches the program for pre-ventilation
	PH_TV (tv)	<b>Pre-ventilation time</b>
	PH_TBRE + PH_TW1	<b>Tapering time</b> - This time ends as soon as the ignition load programmed for pre-ventilation is reached
	PH_TVZ (tvz)	<b>Pre-ignition time:</b> - Appearance of the ignition arc prior to opening the gas valve, which occurs at the start of phase 6
 or 	PH_TSA1_1 + PH_TSA2_1 (tsa)	<b>Safety time</b> - A flame signal should be present before the safety time has elapsed. If this does not occur, another ignition attempt is made.
 or  or 	PH_TI + PH_MODULATION:  • PH_TI.....:  • PH_MODULATION.....:	<b>Burner operation</b> 10: heating operation 11: domestic hot water operation 12: heating and domestic hot water operation (disabled for THI)  Flame stabilisation interval.  In this phase, the LMU (regulator) send its results.
<b>Return to standby:</b> The switch from the operating position to the Standby position is split into "shut-down" and "return to initial setting"		
<b>Shut-down:</b> This occurs when the heating request disappears		
 or 	PH_THL2_1 + PH_TN1	<b>Post-ventilation time</b> - The fan remains on during the post-ventilation time
<b>Return to initial setting:</b> Compulsory switch from the shut-down position to standby. This phase is also used to bring the boiler to standby position after exceptional events such as a RESET.		
	PH_TNB + PH_TLO + PH_TNN:	<b>Return to initial setting</b>



### 2.3 - Principle of air/gas servo-control system

The gas valve fitted on each boiler is controlled by the air pressure supplied by the fan, thus guaranteeing a correct air-gas ratio over the whole modulation range (constant CO<sub>2</sub>). This ratio remains constant despite any pressure drop in the combustion products outlet or the air intake. The air-gas link is pneumatic.

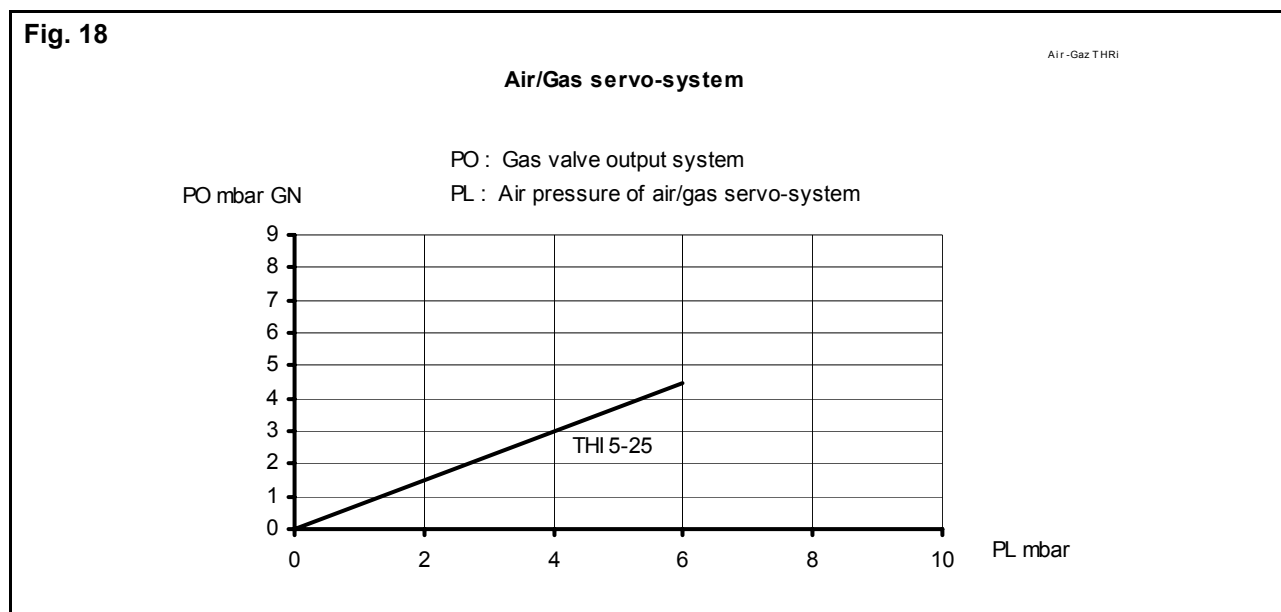

### 2.4 - Air pressure variation procedure

Linear pressure modulation is carried out by a 230 V variable-speed fan controlled by the LMU which calculates the speed needed at any given time to produce the required pressure.

### 2.5 - Emission of pollutants

This air/gas control combined with high efficiency pre-mixing burner enables CO and nitrogen oxide (NO<sub>x</sub>) emissions to be obtained that lie within the values laid down by the most demanding of quality standards.

## 3 - FUNCTIONS

### 3.1 - Anti-freeze function

- Boiler anti-freeze protection: When the boiler temperature is below 5°C, the burner and the heating circuit pump are switched on. When the temperature increases and exceeds 15°C, the burner stops and the pump continues to circulate for 10 minutes.
- Anti-freeze protection for the installation: This function uses the real outside temperature. It adopts a different behaviour depending on the temperature. If no measured outside temperature is available, the function is blocked.

Different reactions can occur depending on the outdoor temperature measured:

- If the outdoor temperature is less than or equal to -5°C, the pumps operate continuously,
- If the temperature lies between -4 and 1.5°C, the pumps operate for 10 minutes every 6 hours.
- If the outdoor temperature is over 1.5°C, the pumps shut-down (no heating request).

Any domestic hot water request is given priority.

- Building anti-freeze protection:

The anti-freeze function of the building is a control function (available with the QAA73 room sensor) used to maintain the room temperature at a minimum value, thus preventing the risk of freezing in the building.

### 3.2 - Anti-legionella function

To provide a substantial degree of protection against the development of pathogenic bacteria in the domestic hot water tank during prolonged shut-downs, the domestic hot water must be heated once a week to a temperature above 60°C.

The anti-legionella function is used for this purpose. It heats the hot water storage tank once a week, on Monday, after the first load, to a 65°C "anti-legionella" temperature.

### 3.3 - Pump run-on after the end of heating

When the heating mode ends, the heating circuit pump remains on for a certain period (depending on the settings used : QAA 73 setting : 544).

In hot water storage systems, when domestic hot water heating ends, the heating circuit pump remains on until the boiler temperature drops below 70°C. During this pump run-on period, the selector valve remains in the "domestic hot water feed" position.

### 3.4 - Pump kick or selector valve kick

If the heating circuit pump has not operated or if the selector valve has not been activated for more than about 24 hours, these elements are activated during operating stops for approximately 5 seconds.

### 3.5 - Boiler overheat protection

The boiler flow sensor in combination with the heating return sensor provide the overheat safety function.

There are two safety levels:

- if the first temperature value is exceeded, this is signalled by a fault code on the display screen,
  - THI 5-25 : 92°C ,
- if the second temperature value is exceeded (100°C), it is signalled by an alarm code on the display. The boiler switches to safety mode. The boiler must be reset to be restarted.

If the temperature is exceeded, the heat present must be evacuated through the fan and circulation pump.

The two elements (fan and circulation pump) remain on until the boiler shell temperature drops.

In the control algorithm, supervision of the temperature difference  $\Delta T$  between the flow and return results in the shutdown of the burner if  $\Delta T$  is above 56°C.

### 3.6 - Monitoring of flue gas temperature

The monitoring of flue gas temperature is not classed as a function related to safety, but is a priority factor in the control of the boiler.

- The boiler operates at minimum power if the flue gas temperature exceeds 85°C,
- The boiler is on "Stand-by" if the flue gas temperature reaches 88°C.

The boiler can only be restarted automatically after 15 minutes if there is no longer a fault.

### 3.7 - Boiler return temperature control

The information from the return sensor is used in the event of a very low flow (large  $\Delta T$ ) (reduction in burner power or shut-down of the burner).

It is also used in control algorithm of the modulating pump (optimization of the boiler thermal efficiency).

It is also enabled for cascade connection.

### 3.8 - Monitoring of hydraulic pressure

This is a priority function with respect to the control of the boiler.

- the power of the boiler is limited if the pressure is above 4 bar,
- the boiler reduces power to 20% if the pressure is between 0.2 and 0.4 bars (fault code is displayed),
- the boiler sets of an alarm and the pump stops if the pressure is lower than 0.2 bars (alarm code is displayed).

The boiler must be reset to clear the fault position if the minimum value has been exceeded.

### 3.9 - Anti-short burner cycle protection function

To prevent the boiler from cutting out suddenly, the power failure differential is adjusted according to the real temperature curve of the boiler.

### 3.10 - Cleaning function

Fig. 19

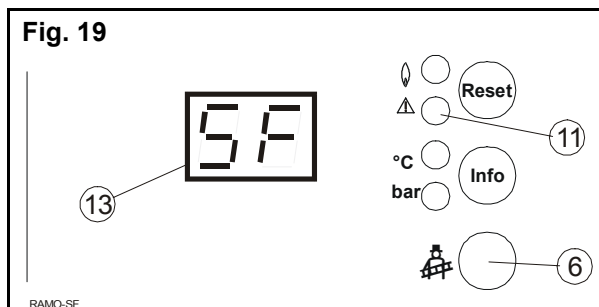

To enable this function, press the clean key (6) until the red LED (11) lights up then release it. The LED (11) then starts flashing once per period. The signalling coded "SF" is displayed on the screen (13).

Heating takes place at maximum heat output until arriving at the maximum temperature  $TKS_{max}$ .



To stop the cleaning function, press on the clean key (6) for 3 seconds then release it.

### 3.11 - Regulator shutdown function

The regulator shut-down function enables the fan motor speed to be set manually via a domestic hot water temperature potentiometer (3), and therefore the heat output of the boiler.

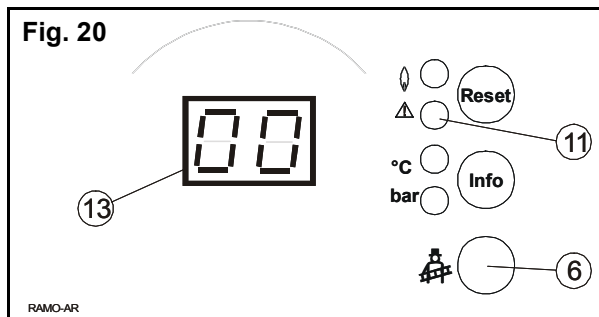
Fig. 20



- Press the clean key (6) for longer than 8 seconds,
  - The red LED (11) flashes twice per period.
  - The codes   appear on the display (13) and flash twice. This code corresponds to the percentage of the boiler heating rate.

The safety function and the "all or nothing" regulator are operating

To disable the regulator shutdown function, press the clean key (6) for 3 seconds then release it.

### 3.12 - LMU programmable key

The following functions can be allocated to the programmable key via the setting KonfigEingang (QAA 73 setting : 614 ):

- 0: The programmable key function is not used.
- 1: Default, modem function enabled, if the contact (X10-04) is closed; disabled if the contact is open.
- 2: Modem function disabled, if the contact (X10-04) is open; enabled if the contact is closed.
- 3: Hot air curtain function enabled, if the contact (X10-04) is closed.

#### **Hot air curtain function (swimming pool):**

This function enables the boiler setting to be raised to its maximum value.

It can be enabled in summer and winter modes.

- Modulation of the burner output is maintained.
- Domestic hot water priority is maintained.
- This function is enabled when the contact is closed.
- There is no effect on the control of a modulating pump.

#### **Modem function:**

The modem function allows the boiler to be placed on "standby" or to be switched off via the telephone. All protection functions (e.g. anti-freeze function, pump kick) remain active.

On the other hand, when this function is activated, some of the other functions are not ensured:

- The antifreeze function of the installation is not guaranteed.
- The anti-legionella function of the unit is no longer used.

### 3.13 - Automatic summer/winter switching (only activated with outside sensor)

The automatic summer/winter switching function enables summer mode to be switched to winter mode (and vice versa) throughout the year without the need for any intervention.

The heating is shut down (when switching from winter mode to summer mode) when the average outside temperature measured over the preceding 24 hours is over the +1°C setting, namely 20°C.

The heating is also started up again (when switching from summer mode to winter mode) automatically when the average outside temperature measured over the preceding 24 hours is below the -1°C setting, namely 18°C.

- Note:

The switchover setting is set to 19°C and can only be changed by using the QAA 73 room sensor.

The automatic mode must obviously be activated on the boiler as well as on the QAA 73 room sensor for the automatic summer/winter switching to be available.

This function is activated by default in the QAA 73 basic configuration.

## 4 - DIFFERENT VERSIONS OF THE THI



The standard configuration is for the connection of:

- one radiator circuit (CC1),
- one under-floor heating circuit (CC2) via the 2<sup>nd</sup> circuit clip-in kit.

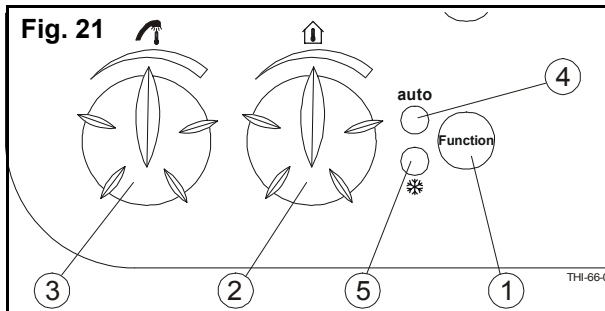

### 4.1 - THI basic model (without outside sensor, without room sensor)

The heating and domestic hot water flow temperatures are set manually with the respective potentiometers (2 and 3) on the boiler control panel.

The regulator (LMU management unit) thus sets the heating rate required to provide the heating and hot water settings specified by the user.

The "Function" key (1) switches between the summer (hot water only) and winter (heating and hot water) modes. (The auto function is not accessible in this case).

Please refer to section 4.6 - page 15 - Chapter II - TECHNICAL SPECIFICATIONS.

*Note: The installation of under-floor heating is not possible in this configuration.*

### 4.2 - THI with outside sensor only

#### 4.2.1 - Principle

The domestic hot water temperature is set manually using the potentiometer (3) on the boiler control panel.

The heating flow temperature is calculated automatically by the regulator (LMU management unit), and determined according to the outside temperature and the slope of the heating curve. The room temperature can be modified by only + or - 3°C using the heating temperature potentiometer (2).

The "Function" key (1) switches between the summer (hot water only) and winter (heating and hot water) modes.

Refer to section 4.6 - page 15 - Chapter II - TECHNICAL SPECIFICATIONS.

*Note:*

- An under-floor heating system can be connected by following the instructions in section 4.2.3 - page 26.

#### 4.2.2 - Modification of the room temperature

The room temperature setting is pre-set to 20°C on the LMU management unit, it can be modified if required:

- Set the heating temperature potentiometer (2) to the required value,
- The display indicates the correction made by +/- 3°C with respect to the 20°C value,

The correction is recognised by the LMU by leaving the potentiometer on the required position.

#### 4.2.3 - Modification of the heating curve slope

The heating curve slope depends on the characteristics of the building and the size of the heating installation.

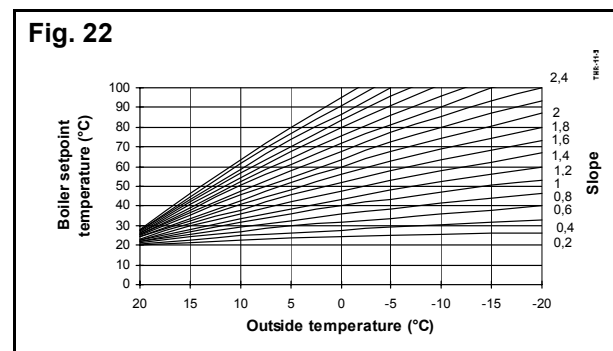

The slope of the heating curve is pre-set in the factory to the value 15 for a radiator system and theoretically gives an room temperature of 20°C for a standard installation.

*Note: The maximum permitted flow temperature is limited by TKSmax (line 504, via the QAA73 room sensor).*

The characteristics of the living area (heating surface, insulation) may require the pre-set values on the LMU to be adjusted.











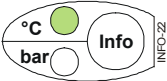







- For a radiator heating system:

- Reset the room temperature by  $\pm 3^{\circ}\text{C}$  (section 4.2.2 - page 26) then if this correction is not sufficient,
- Modify the heating curve slope (section 4.2.3.1 - page 27).







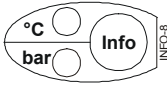











- For an under-floor heating system:

- Reset the value of the heating curve slope of 15 (factory setting) to 8 (section 4.2.3.1 - page 27) and according to the installation requirements,
- Modify the room temperature by  $\pm 3^{\circ}\text{C}$  (section 4.2.2 - page 26).

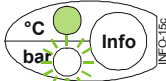

#### 4.2.3.1 - Procedure for modifying the parameters of the heating curve slope

1	Initial display: Green LED "°C" is on  . The display shows the heating flow temperature.
2	Press the  key until  is displayed then release it and press for the same period until  is displayed (the display indicates  then  : intermediate positions).
3	After a few moments,  is displayed.
4	Press on the  key twice until  is displayed on the screen.
5	 setting of the slope permutes with  the default value of the slope.
6	Only when the display shows  press the  key until the "bar" LED flashes: 
7	Increase the value  by pressing  until the value  is displayed.
8	Store the value  by pressing the  key for a certain time until the LEDs "°C" and "bar"  extinguish
9	Return to the initial display

**4.2.3.2 - Procedure for modifying the parameters of the parallel shift of the heating curve**

1	Initial display: Green LED “°C” is on  The display shows the heating flow temperature.
2	Press the  key until  is displayed then release it and press for the same period until  is displayed (the display indicates  then  : intermediary positions)
3	After a few moments,  is displayed.
4	Press on the  key three times until  is displayed on the screen.
5	 setting of the parallel shift permutes with  the default value of the shift.
6	Only when the display shows  press the  key until the “bar” LED flashes: 
7	Increase the value  by pressing  until the value  is displayed.
8	Store the value  by pressing the  key for a certain time until the LEDs “°C” and “bar”  extinguish
9	Return to the initial display

**4.2.3.3 - Return to the initial display**

Procedure	Observation
Press the  key until the  display appears then release the key.	This enables you to return to the initial position (i.e. the display shows the heating flow temperature) when the procedures 4.2.3.1 - page 27 and 4.2.3.2 - page 28 are being applied or during any other actions on the boiler control panel.

### 4.3 - THI with outside and room sensors

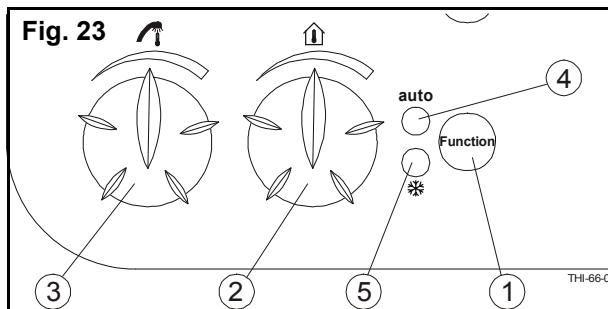

Installing the QAA73 room sensor on the boiler cancels the functions of the setting potentiometers of the heating (1) and domestic hot water (2) temperatures on the boiler control panel. All the temperatures, the operating settings and the heating programmes are set on the QAA 73 (please refer to the instructions supplies with the sensor).

Note:

- For heating by radiators or by under-floor heating, refer to section 4.2.3 - page 26.

#### 4.3.1 - Automatic summer/winter switching

Refer to section 3.13 - page 25.

#### 4.3.2 - Room temperature compensation function

This function corrects the boiler flow temperature according to the real room temperature measured by the QAA 73 room sensor.

The QAA 73 can be deactivated or configured differently according to the wishes of the customer (refer to heating engineer setting line 75).

Note:

- The "room temperature compensation" function is activated by default on the CC1 heating circuit - standard configuration of the sensor.
- The function is activated if the room sensor is placed in a room whose temperature is typical of the accommodation. This room must not be fitted with temperature control radiators. The room sensor must be fitted away from sources of heat or cold.

When the room temperature compensation is inactive, the QAA 73 room sensor becomes a remote control device acting on the heating curve for the day-night temperature drops.

#### 4.3.3 - Auto-adapt function

This function automatically corrects the heating curve by measuring the real room temperature.

The auto-adapt function is deactivated in the basic configuration. It can be activated via line 77 by using the +/- keys.



**When the auto-adapt function is activated, the room temperature compensation function must also be activated, section 4.3.2 - page 29.**



# IV - INSTALLATION

## 1 - GENERAL

Installing a wall-mounted gas boiler presents no particular difficulty.

The installation of the boiler must be carried out by a competent person in accordance with the relevant requirements of the Gas Safety (Installation and Use) Regulations, Building Regulations, Model Water Byelaws and the Building Standards (Scotland) Regulations. It must also comply with the current I.E.E. Wiring Regulations and the relevant recommendations of the following British Standard Codes.

Regulations and the relevant recommendations of the following British Standard Codes of Practice.

- CR331.3 Low pressure installation pipes.
- BS.5449.1 Forced circulation hot water systems.
- BS.5546 Installation of gas hot water supplies for domestic purposes.
- BS.5440.1 Flues (for gas appliances of rated input not exceeding 60 kW).
- BS.5440.2 Air supply (for gas appliances of rated input not exceeding 60 kW).
- BS.6798 Boilers of rated input not exceeding 60 kW.

Note:

- The boiler is only suitable for installation in a sealed system and must not be used with an open vented system.

### LOCATION OF BOILER

The boiler can be installed on the inner face of an external wall - and some internal walls - providing they are flat, vertical and capable of adequately supporting the weight of the boiler and any ancillary equipment.

The boiler may be installed in any room or internal space, although particular attention is drawn to the requirements of the current I.E.E. Wiring Regulations and, in Scotland, the electrical provisions of the Building Regulations applicable in Scotland with respect to the installation of the boiler in a room or internal space containing a bath or shower. Where installation is in a room containing a bath or shower, any electrical switch or boiler control utilising mains electricity should be situated so that it cannot be touched by a person using the bath or shower.

Where installation will be in an unusual location, special procedures may be necessary and BS.6798 gives detailed guidance on this subject.

A compartment used to enclose the boiler **MUST** be designed and constructed specially for this purpose.

An existing cupboard or compartment may be used provided it is modified for the purpose. Details of essential features of cupboard/compartment design, including airing cupboard installations, are given in BS.6798.

In siting the boiler, the following limitations **MUST** be observed:

- 1) *The position selected for installation **MUST** allow adequate space for servicing in front of the boiler and for air circulation around the boiler.*
- 2) *This position **MUST** also permit the provision of a satisfactory balanced flue termination.*

Note:

- If the boiler is to be fitted in a timber framed building, it should be fitted in accordance with the British Gas publication "Guide for Gas Installations in Timber Frame Housing". Reference DM2. If in doubt, advice must be sought from the Local Gas Region of British Gas.

When siting the boiler, provision must be made for the disposal of the condensate, see Section 4 - Condensate drain.

The pressure relief valve connection should be routed to an external, visible point where the discharge of steam or water cannot create a hazard to persons or property. BS.5449: 1 refers.

### GAS SUPPLY

Installation pipes should be fitted in accordance with CP.331.3.

The complete installation must be tested for soundness and purged in accordance with CR331.3.

### FLUEING

Detailed recommendations for flueing are given in BS.5440.1. The following notes are intended for general guidance.

### AIR SUPPLY

#### a) - For room-sealed systems

Detailed recommendations for air supply are given in BS.5440.2. The following notes are intended for general guidance.

Where the boiler is to be installed in a room or internal space, the boiler does not require the room or internal space containing it to have a permanent air vent.

Where the boiler is to be installed in a cupboard or compartment, permanent high and low level air vents are required for cooling purposes in the cupboard or compartment. Both vents must communi-

cate with the same wall to outside air.

The minimum effective area of the permanent air vents required in the cupboard or compartment are given in Table 3.

**Table 3 AIR VENT AREAS**

Position of air vents	Air from room or internal space	Air direct from outside
High level	245 cm <sup>2</sup>	123 cm <sup>2</sup>
	38 in <sup>2</sup>	19 in <sup>2</sup>
Low level	245 cm <sup>2</sup>	123 cm <sup>2</sup>
	38 in <sup>2</sup>	19 in <sup>2</sup>

**b) - For natural draught system:**

Detailed requirements are given in BS 5440.2

**WATER CIRCULATION SYSTEM**

The expansion vessel is suitable for systems up to **80 litres** water content. For systems in excess of this capacity an additional pressurised expansion vessel will be required. BS7074 and "British Gas Specifications for Domestic Wet Central Heating Systems' Part 3 gives guidance in this subject.

The central heating system should be in accordance with the relevant recommendations given in BS.6798 and, in addition, for small bore and micro-bore systems - BS.5449.1. The domestic hot water system, if applicable, should be in accordance with the relevant recommendations of BS.5546.

Copper tubing, to BS. 287 1. 1, is recommended for water carrying pipework.

**ELECTRICAL SUPPLY**

- Wiring external to the boiler must be in accordance with the I.E.E. Wiring Regulations and any local regulations.

## 2 - VENTILATION

### 2.1 - THI models with conventional flue connection

- All fuel burning devices consume a quantity of air that is proportional to their power. Efficient ventilation of the installation's premises is therefore necessary (according to installation standards).
  - High ventilation, with a free section of at least 100 cm<sup>2</sup>, should be placed at least 1.80 m above the ground, as well as an air inlet, in the lower part, of a cross-section of 100 cm<sup>2</sup>.
- To avoid any form of corrosion, the combustion air must be free of any harmful agents. They are thought to encourage the corrosion of halogenated hydrocarbons, containing combinations of chlorine or fluorine, which can be found in solvents, paints, glues, gas propellants and domestic cleaning products, etc.

### 2.2 - THI models with balanced flue connection

When the THI boiler is installed with the horizontal or vertical balanced flue kits that are supplied as options, the combustion circuit is sealed in relation to the installation premises.

These sealed units can be installed on premises that either have or do not have windows or air inlets. However, all measures must be taken to ensure that the temperature of the installation room does not exceed 45°C (ventilation).

### 3 - COMBUSTION PRODUCT FLUEING



The combustion product outlet systems described in this manual are systems normally used on the European market. However, some of them cannot be used in all the countries of the EEC. The installer or client must ensure that the flue system chosen complies with local installation regulations.

#### 3.1 - Conventional flue outlets (B<sub>23</sub> model)

- The THI boiler operates by condensation, which involves the use of a sealed drain outlet. The combustion products are saturated with water vapour and continue to condense onto the walls of

the lining. The condensates must therefore be collected at the base of the conduit and directed to the drain. The condensates are acids (PH4), so the use of a stainless steel conduit is recommended.

- Systematically check that the condition and the cross-sectional area of the flue are correctly adopted to open flued combustion product extraction. If they are defective, carry out repairs or tubing in accordance with the installation standard.
- If the boiler is installed in premises that have mechanical air extraction, check regularly that this does not cause negative pressure.
- The conventional flue connection must be installed by retaining an upwards slope towards the flue (2% minimum). Use a rigid flue that has a smaller diameter than that of the boiler.

Fig. 24

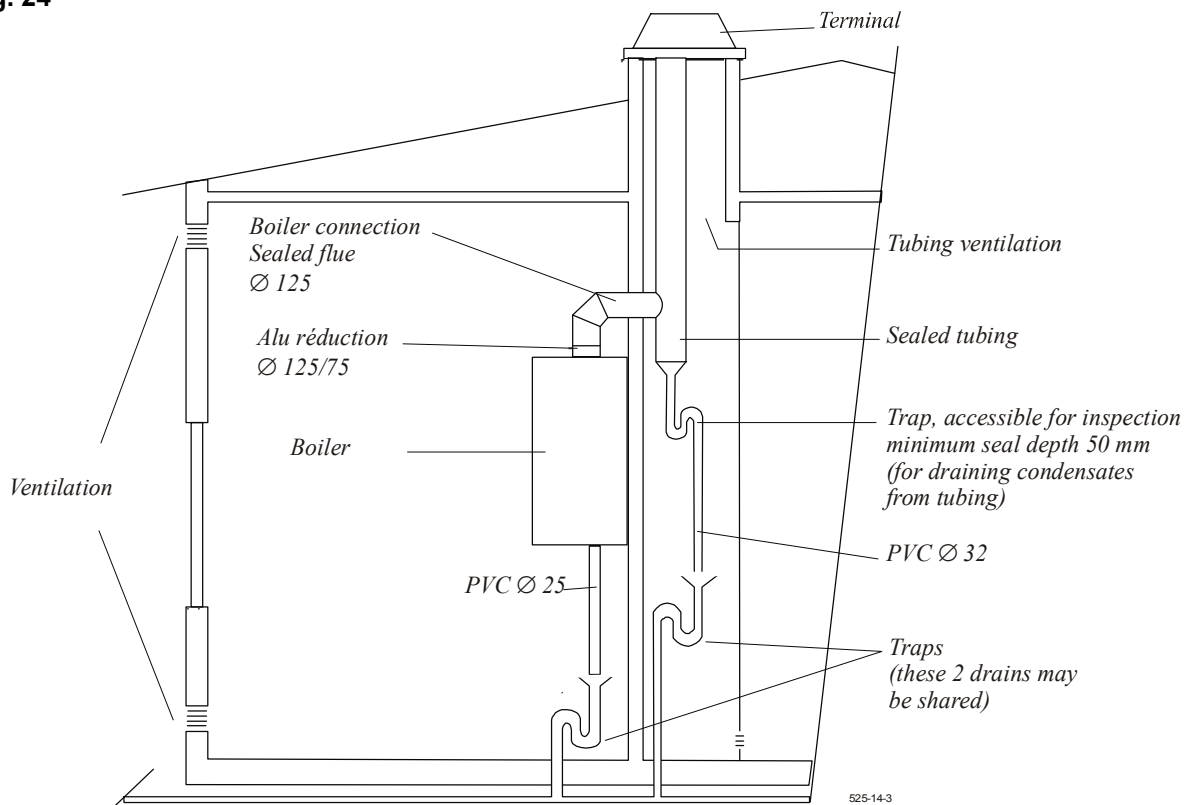

### 3.2 - Balanced flue outlet

#### 3.2.1 - Balanced flue system installation requirements:

The recommended clearance distances according to the installation standards are:

- **A = 0.30 m:** minimum clearance distance of the combustion production extraction outlet axis to any opening,
- **B = 0.30 m:** minimum distance from the axis of the combustion production extraction outlet to any other ventilation air inlet,
- **C = 2.00 m:** combustion product extraction outlet and air inlet of sealed circuit units with openings at less than 2.00m from the ground must be efficiently tam-

per-proof so as to prevent any intervention that could affect correct functioning.

- **D = 0.30 m:** centre distance from the combustion product extraction outlet to the ground, from a roof overhanging or above a balcony,
- **E = .60 m:** distance of a combustion product extraction outlet from a hedge or plant,
- **F = 0.15 m:** space between the combustion product extraction outlet and a gutter or drainpipe.

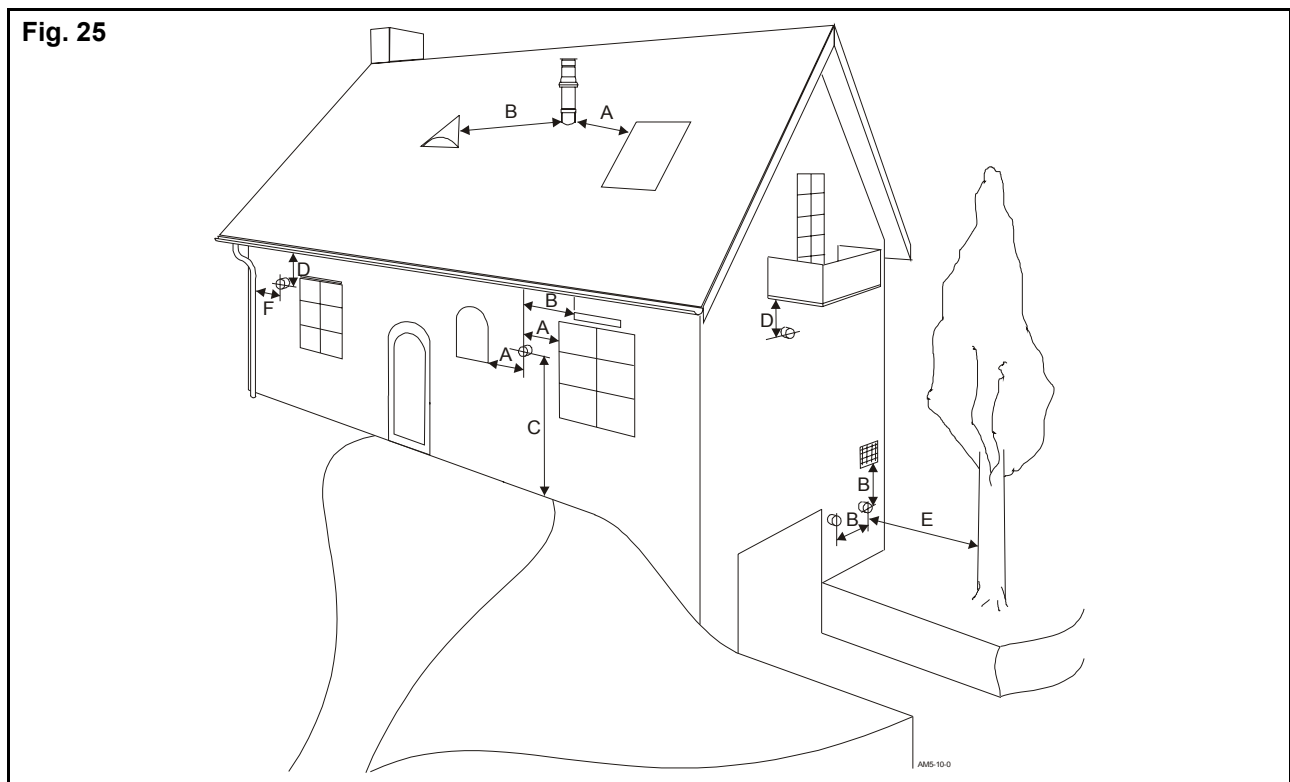

**Check that the air inlet and combustion product extraction outlet tube and bend joints are properly sealed after mounting.**

**Air intake by the burner and extraction of combustion product is carried outside the premises by using concentric tubes.**

### 3.2.2 - Drainage by horizontal balanced flue (C<sub>13</sub>)

#### Recommendations



Horizontal balanced flue installation is possible when the wall next to the boiler leads to a well-ventilated area on the outside.

Do not place the flue terminal at the front of the building or in an access area (possible obstruction).

The horizontal balanced flue can be fitted to the right or lefthand side or directly to the rear of the boiler and can cross a wall-thickness of 1 metre maximum.

Two balanced flue terminals from two separate boilers, positioned side by side, must be separated by a minimum distance of 0.3 metres.

When installing the horizontal balanced flue, use a 2% upward grade towards the outside for the combustion product tube.

To make assembly easier, apply liquid soap over 5 cm of the section of the tube to be fitted.

- Standard balanced flue length: **L = 1 m**
- Maximum linear length of horizontal flue: **Lmax = 4 m**

#### 3.2.2.1 - 1 m horizontal balanced flue kit (option)

See kit assembly guide

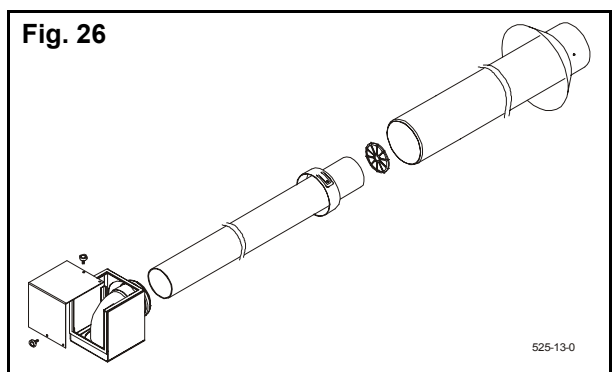

Reference	Length mm
V00.15225	1000

#### 3.2.2.2 - 1 m polypropylene concentric flue extensions (option)

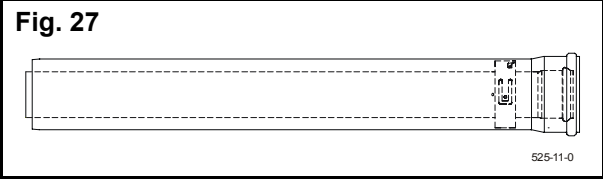

Reference	Length mm	∅ int. mm	∅ ext. mm
V00.17572	1000	75	110

#### 3.2.2.3 - Polypropylene concentric bends (option)

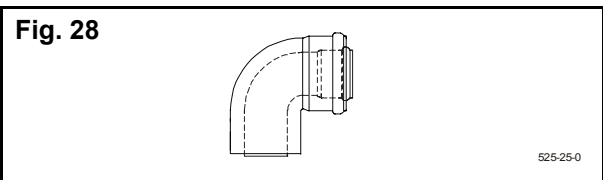

Reference	Bend type	∅ int. mm	∅ ext. mm
V00.17573	90°	75	110

Note:

- Each 90° bend added reduces the total authorised length by 1 m

#### 3.2.2.4 - Adapting collar for the horizontal balanced flue

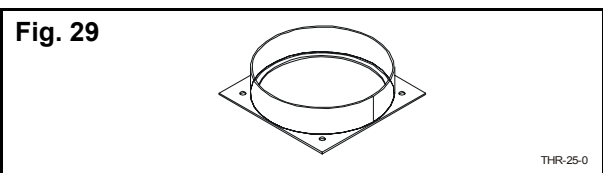

Reference	∅ int. mm
V00.15249	110

### 3.2.2.5 - Installation examples

Please refer to the guide when installing the kit.

Note:

- For lengths greater than 1 m (standard horizontal flue kit) use the extensions and bends supplied as an option.

$$L_{max} \leq 4 \text{ m}$$

#### 3.2.2.5.1 - Straight horizontal balanced flue

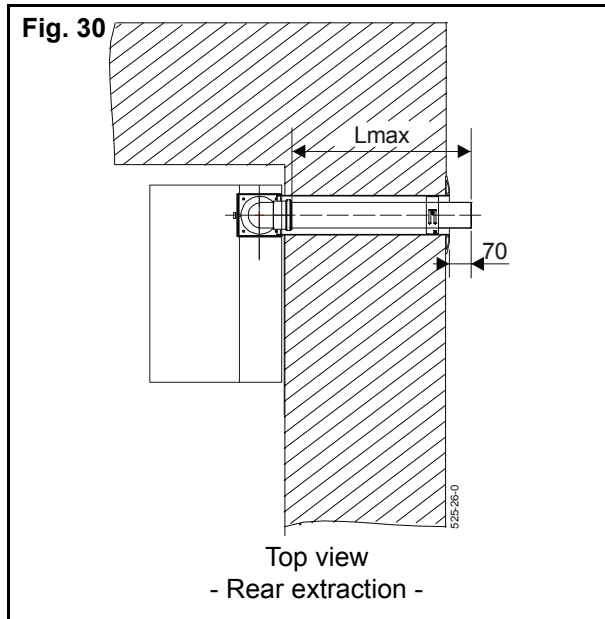

Accessory:

- 1 horizontal balanced flue kit -  $l = 1 \text{ m}$ .

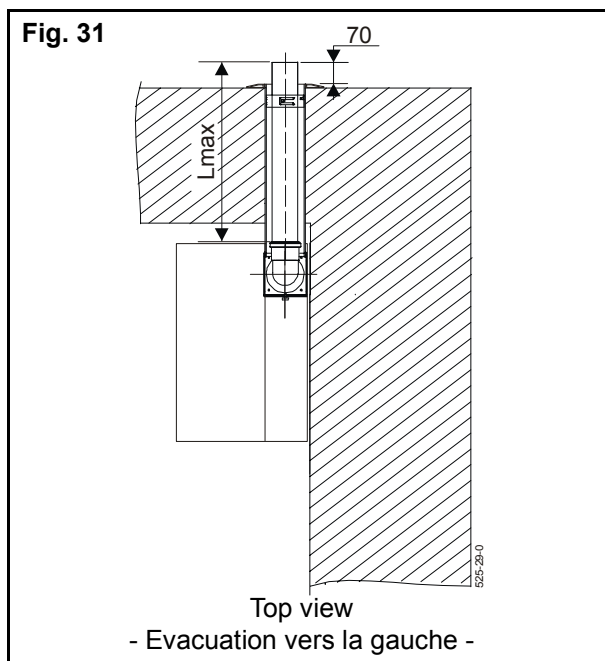

Accessory:

- 1 horizontal balanced flue kit -  $l = 1 \text{ m}$ .

Fig. 32

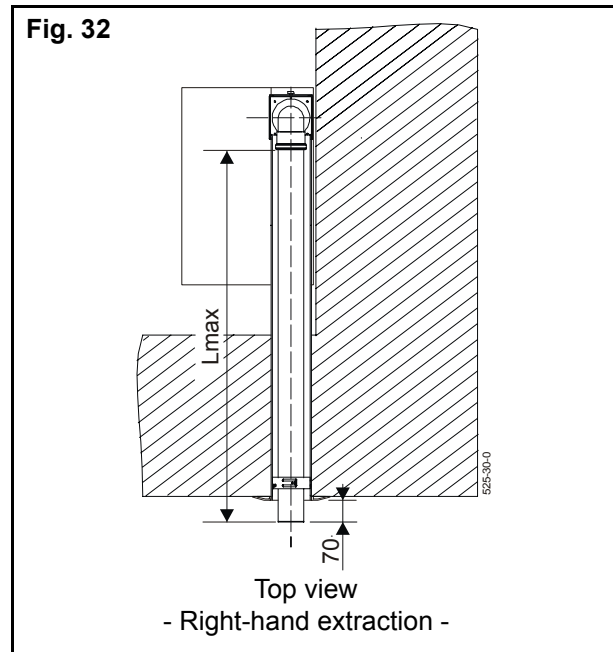

Accessory:

- 1 horizontal balanced flue kit -  $l = 1 \text{ m}$ .

#### 3.2.2.5.2 - Flue with bend:

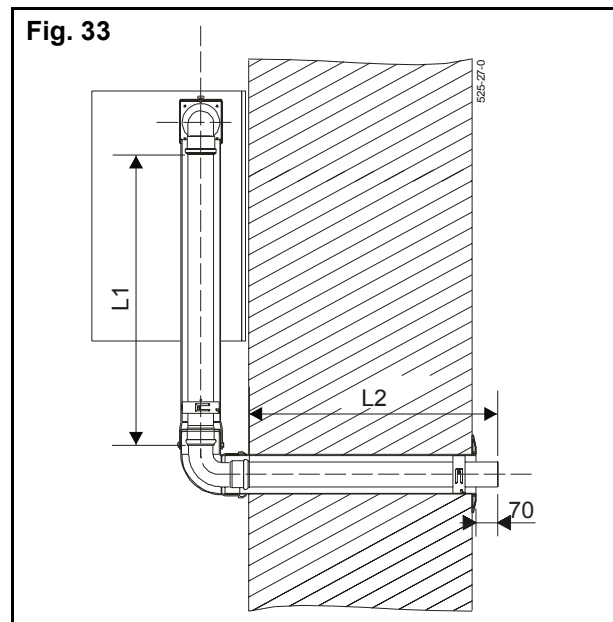

Accessories:

- 1 horizontal balanced flue kit -  $l = 1 \text{ m}$ .
- 1 concentric extension  $\varnothing 75/110$  -  $l = 1 \text{ m}$ ,
- 1 x 90° concentric bend  $\varnothing 75/110$ .

$$L_{max} = L1 + 1 \text{ m} + L2 \leq 4 \text{ m}$$

Note :

- Each 90° bend added reduces the total permitted length by 1m.

### 3.2.2.5.3 - Straight horizontal balanced flue with collar

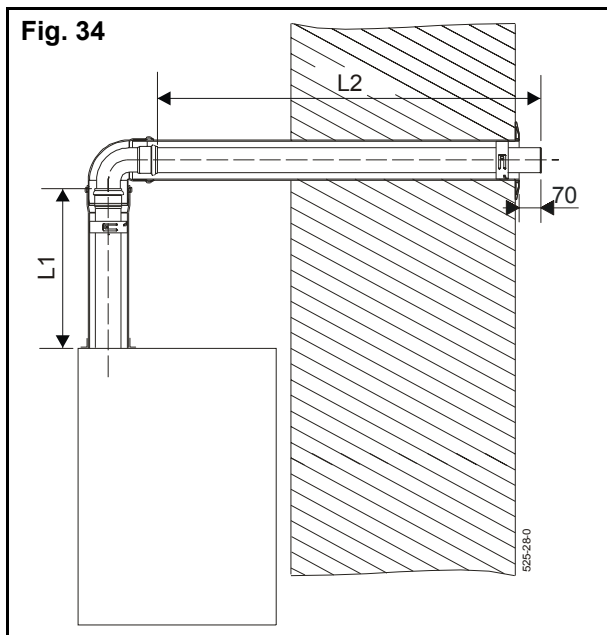

Accessories:

- 1 horizontal balanced flue kit - **l = 1 m**,
- 1 adapting collar for the horizontal balanced flue,
- 1 concentric extension  $\text{Ø } 75/110$  - **l = 1 m**,
- 1 x 90° concentric bend  $\text{Ø } 75/110$ .

$$L_{\text{max}} = L1 + L2 \leq 4 \text{ m}$$

Note:

- The metal box and bend  $\text{Ø } 75$  from the flue kit must not be used for this type of installation.
- The concentric extension can be cut to adapt to the required collar height.

### 3.2.3 - Extraction by vertical balanced flue (C<sub>33</sub>)

Besides the previously mentioned installation regulations pertaining to flues, the vertical flue terminal must allow a minimum distance of 30 cm between the roof level (sloping or flat) and the air intake zone.

The proximity of two terminals is also regulated: it is recommended that two adjoining terminals should be placed in the same horizontal plane. If this cannot be applied, the axis of the lower terminal must be at a distance of at least 0.40 m from the closest point of the air intake hole of the highest terminal.

Maximum length of vertical flue = 10 m

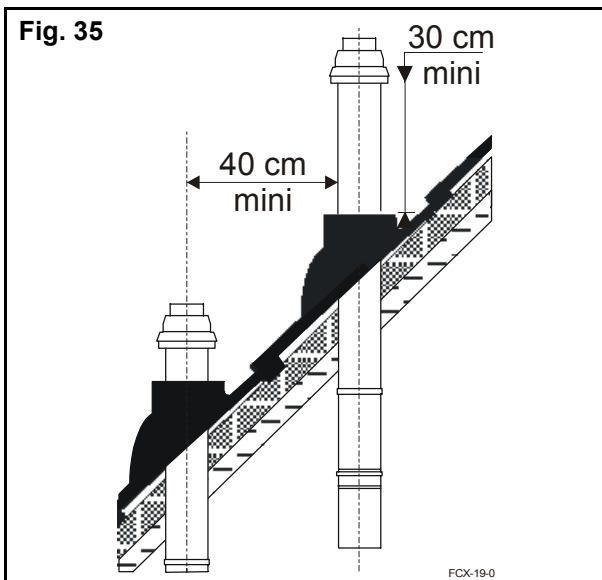

#### Recommendations



**Horizontal parts must be avoided to prevent any risk of condensate retention.**

**It is recommended to use 45° bends rather than 90° bends.**

**Use fastening collars for the vertical parts.**

**Position the terminal at least 1 metre from a vertical wall (end walls).**

**Apply liquid soap to approximately 5 cm of the part of the tube to be fitted to make assembly easier.**

### 3.2.3.1 - Polypropylene/PVC concentric vertical terminal (option)

For sloping roofs.

Fig. 36

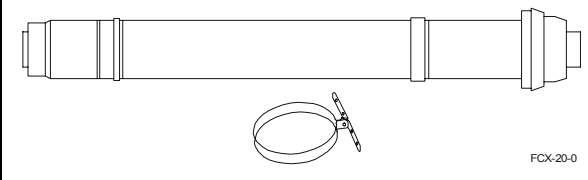

Reference	Colour	Length (*) mm	∅ int. mm	∅ ext. mm
N40.28393	Tile	1080	80	125
N40.28394	Black	1080	80	125

(\*) Useful length under sleeve tile - l = 0.43 m

### 3.2.3.2 - Sleeve tile with adaptive coupling (option)

Fig. 37



Reference	Slope	Type of covering	Colour
N40.12165	25° - 45°	Tile*	Tile
N40.12166	35° - 55°	Tile*	Tile
N40.12167	35° - 55°	Slate - Shingle	Black

\*Suitable for all types of tiles, for flat tiles < 8 mm use the Slate model

If accessories of any other brand are used, our guarantee of watertightness will be automatically void

### 3.2.3.3 - Polypropylene/PVC concentric extensions (option)

Joint fitting.

Fig. 38



Reference	Length mm	∅ int. mm	∅ ext. mm
N40.28397	500	80	125
N40.28398	1000	80	125

(\*) Useful length after assembly - l = 0.45 m or 0.95 m



**3.2.3.4 - Polypropylene/PVC concentric bends (option)**

Joint fitting.

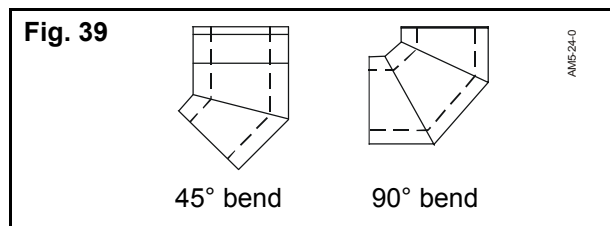

Reference	Type of bend	∅ int. mm	∅ ext. mm
N40.28395	45°	80	125
N40.28396	90°	80	125

Each 45° bend added reduces the total permitted length by 0.5m.

Each 90° bend added reduces the total permitted length by 1m.

**3.2.3.5 - Polypropylene roof plate (option)**

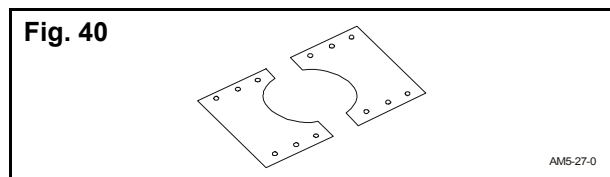

Reference	Colour
A90.12172	noir

**3.2.3.6 - Fastening collar (option)**

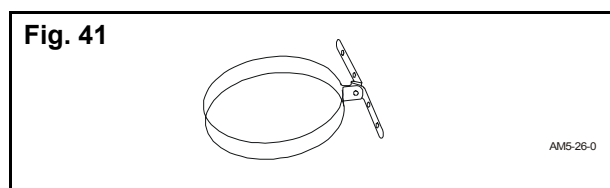

Reference	Quantity	∅ mm
B00.29727	3	125

These collars are essential to fix the vertically positioned extensions so that the boiler outlet does not bear the weight of the conduits.

**3.2.3.7 - Adapting collar for the vertical balanced flue**

See assembly instructions for the part.

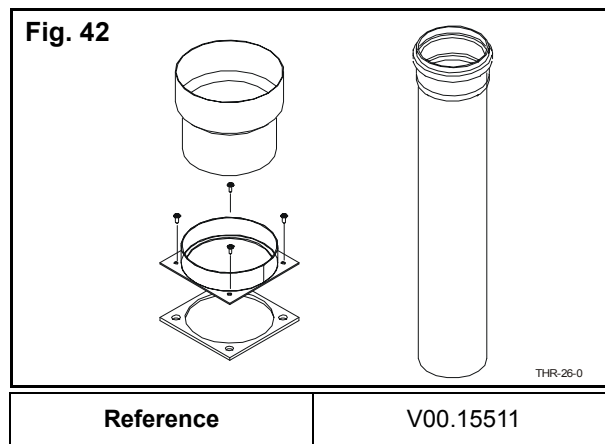

Reference	V00.15511
-----------	-----------

3.2.3.8 - Installation examples

3.2.3.8.1 - Straight configuration

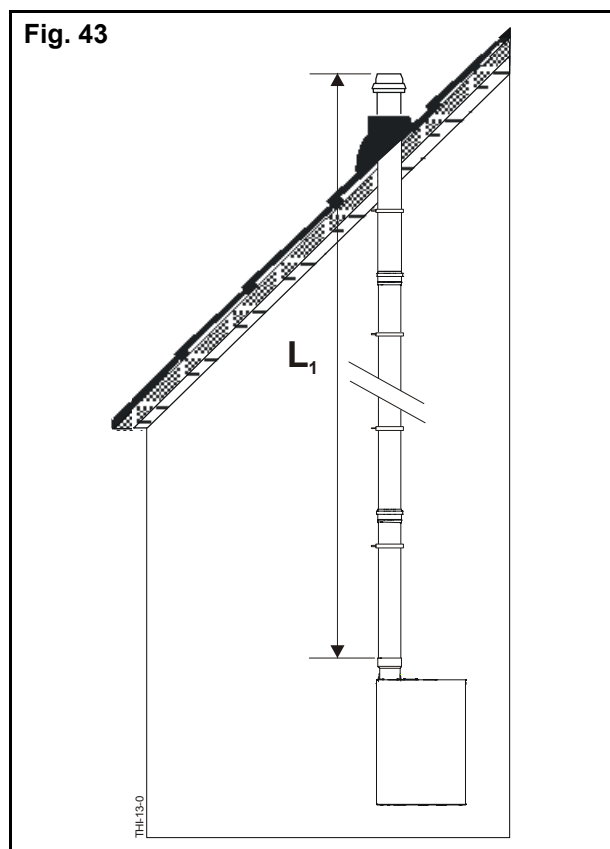

Accessories:

- Vertical balanced flue adapting collars,
- Concentric extensions Ø 80/125,
- 1 concentric vertical terminal Ø 80/125,
- 1 vertical terminal fastening collar (delivered with vertical terminal),
- 1 sleeve tile with adaptive coupling depending on the type of roofing and roof slope,
- 1 roof plate,
- 3 fastening collars Ø 125,

$$L_{max} = L1 \leq 10 \text{ m}$$

3.2.3.8.2 - Configuration with bends

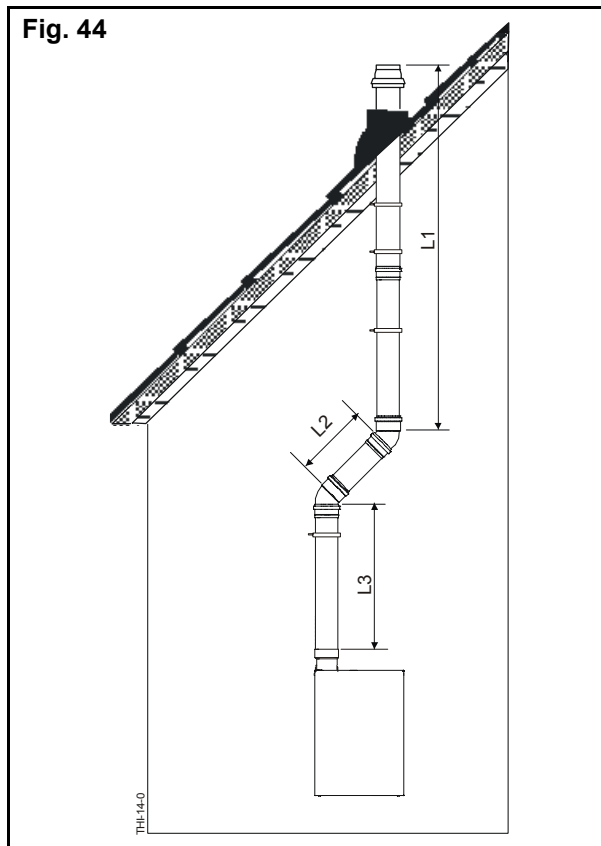

Accessories:

- Vertical balanced flue adapting collars,
- 3 concentric extensions Ø 80/125,
- 2 x 45° concentric bends Ø 80/125
- 1 concentric vertical terminal Ø 80/125,
- 1 vertical terminal fastening collar (delivered with vertical terminal),
- 1 sleeve tile with adaptive coupling depending on the type of roofing and roof slope,
- 1 roof plate,
- 3 fastening collars Ø 125,

$$L_{max} = L1 + 0,5 \text{ m} + L2 + 0,5 \text{ m} + L3 \leq 10 \text{ m}$$

Note:

- Each 45° bend added reduces the total permitted length by 0.5m.

4 - SUPPORT BRACKET

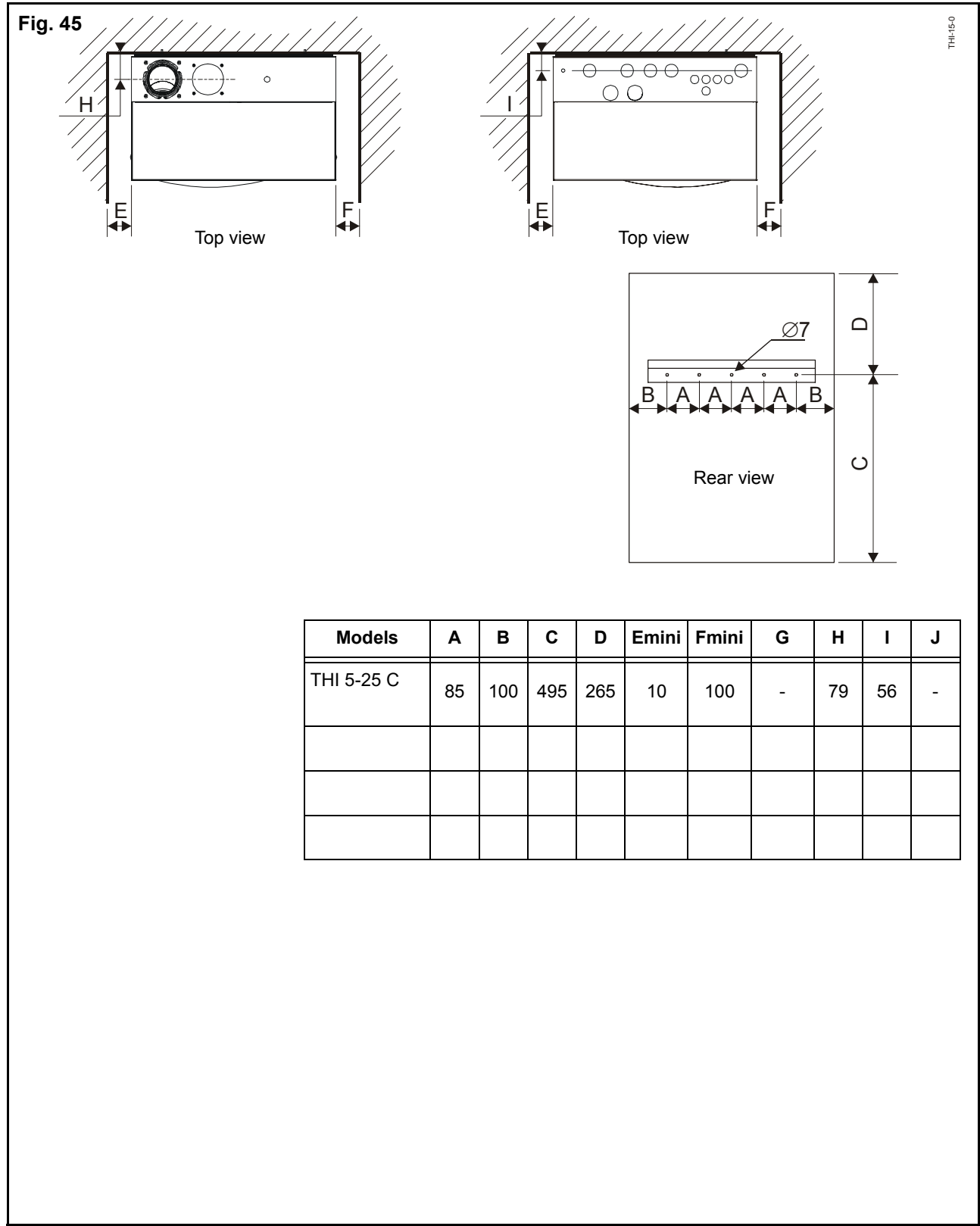

## 5 - HYDRAULIC CONNECTION

### 5.1 - Recommendations



When the boiler is assembled on an old installation, make sure that the installation is rinsed with fresh water, so as to clear any sediment stagnating in areas where the flow is slow.

To prevent circulation noises in an installation featuring temperature controls, the following is recommended:

- Do not fit all the radiators with temperature controls,
- Fit a differential valve,
- Use an automatic speed variation pump.

In accordance with the decree of the Ministry of Health for the protection of the drinking water supply, the filling system must be fitted with a disconnecter of type CB (non-controllable pressure zone).

Never position the isolation valve between the safety control and the hot water tank.

### 5.2 - Accessories to connect, install or adjust

**Bleed:**

The bleed of the circulating pump features a flexible tube that can be connected to the outlet (condensate extraction funnel).

**Safety control (for hot water production models):**

- The safety control must be installed at a low point (0.25 m from the floor) in order to enable the extraction of the domestic hot water tank by siphoning. Otherwise, use a weld with a low point drain tap.
- It is normal for the d.h.w. safety control to leak a little water during the pre-heating of the

hot water tank. If the cold water pressure exceeds 4 bars, the installation of a pressure-reducing valve on the cold water inlet is advised.

**Isolating valve:**

It is recommended to place isolation valves on the installation's flow-returns in order to allow possible servicing on the boiler without having to drain the installation.

**Safety valve:**

This must be connected to the used water drain via a siphon funnel.

**Condensate outlet:**

The condensate outlet must be connected to an accessible siphon.

**Expansion vessel:**

If the installation capacity is over 100 litres, an extra expansion vessel to the boiler expansion vessel will be added.

The correct operation of the boiler requires an installation pressure of at least 1 bar.

If the installation is a renovation and uses an open tank, this must be removed and replaced with a closed tank (the boiler can be equipped with one originally) to seal the circuit.

The vessel should be able to support an expansion of 6% of the total water capacity of the heating circuits. But it is important to note, in order to guarantee this expansion, that the useful capacity of a vessel does not equal its actual capacity.

**Example:**

- Installation: 100 litres
- Domestic hot water tank: 5 litres
- Boiler: 2,5 litres
- Total water capacity: 107,5 litres

**Conditions:** Using a vessel pre-loaded to 1 bar (under floor boiler = ground floor heating + 1 floor), heating safety valve calibrated at 3 bars, installation filled cold at 1 bar.

- Vessel efficiency calculation (R):

$$R = \frac{(\text{Safety Pressure} - \text{Filling pressure})}{\text{Safety Pressure}}$$

$$R = \frac{(3 + 1) - (1 + 1)}{(3 + 1)} = 0,5$$

+ 1) = the transformation of relative pressures into absolute pressures

- Calculation of the useful capacity of the vessel (Cu):

$$C_u = \text{total volume} \times \text{expansion}$$

$$C_u = 107,5 \times 0,06 = 6,45 \text{ dm}^3$$

- Calculation of the real capacity of the vessel (Cr):

$$C_r = \frac{C_u}{R}$$

$$C_r = \frac{6,45}{0,5} = 12,9 \text{ litres}$$

**5.3 - Under-floor heating recommendations**

(Refer to the § 1 - page 48 - chapter V - SETTINGS OF THE INSTALLATION TYPES ).

When the boiler directly supplies an under floor heating system and this system is also used to produce domestic hot water (THI 5-25C + BS) make sure that the installation has sufficient extra capacity to utilise the excess heat produced at the end of the domestic hot water heating cycle. This capacity should be in the region of 10 liters.

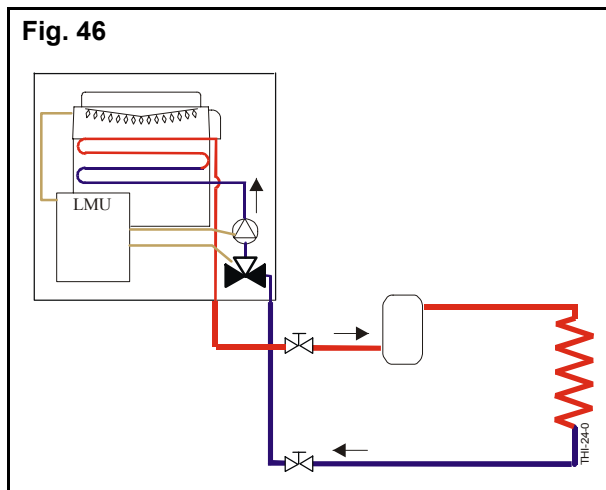

**5.4 - Heat exchanger flow rate**

Whenever the size of the installation is such that it absorbs the maximum power of the boiler, please ensure that there is the following minimum water flow in the exchanger.

Type	Flow
THI 5-25	1.03 m <sup>3</sup> /h

If the boiler directly feeds under-floor heating at low ΔT. the necessary flow may be higher. In this case, please take the ΔP of the boiler into account and if necessary install a header between the boiler and the installation.

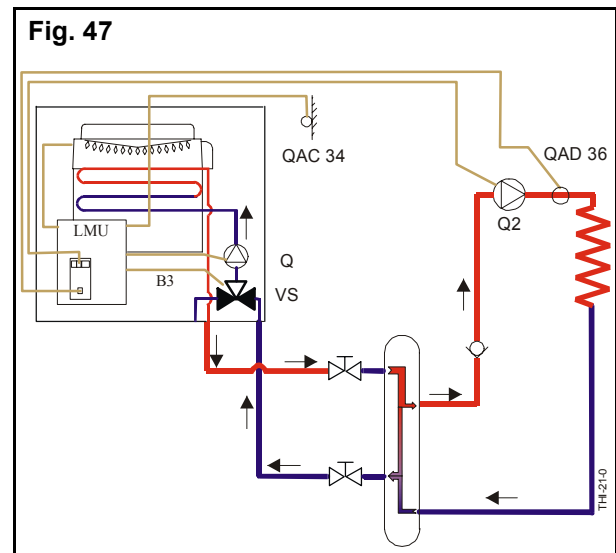

5.5 - Hydraulic connection for THI 5-25 C

Fig. 48

- 1) Gas inlet
- 2) Gas cock
- 3) Boiler
- 4) Radiator
- 5) Heating flow isolation valve
- 6) Heating flow
- 7) Heating return isolation valve
- 8) Heating return
- 9) Cold water inlet
- 10) Filling valve
- 11) Filling system
- 12) Isolation valve
- 13) Drain for condensates, valve, bleed
- 14) Removal towards drain
- 15) QAA73 room sensor (option)
- 16) Outside sensor QAC 34

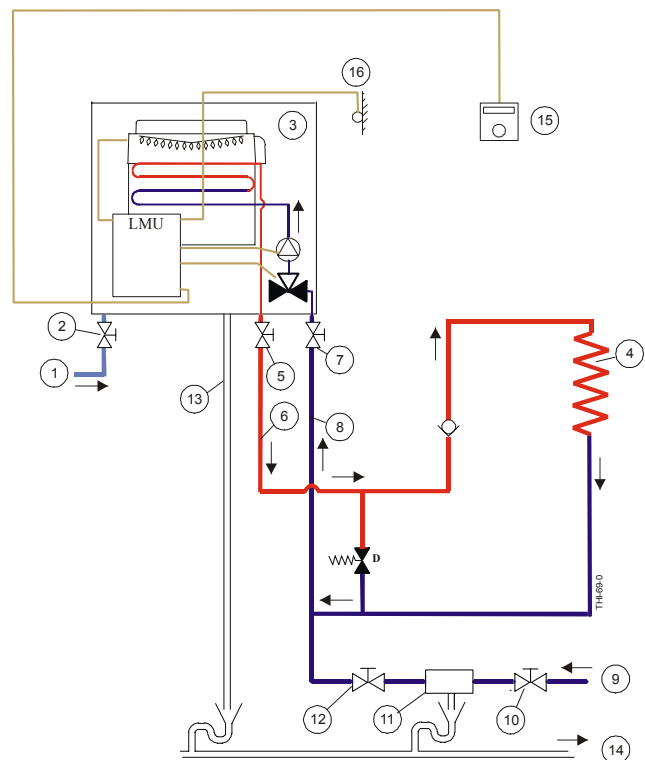

5.6 - Hydraulic connection for models THI 5-25C+ DHW production system of type BS

Fig. 49

- 1) Gas inlet
- 2) Gas cock
- 3) Boiler
- 4) Radiator
- 5) Heating flow isolation valve
- 6) Heating flow
- 7) Heating return isolation valve
- 8) Heating return
- 9) Cold water inlet
- 10) Filling valve
- 11) Filling system
- 12) Isolation valve
- 13) Drain for condensates, valve, bleed
- 14) Removal towards drain
- 15) QAA73 room sensor (option)
- 16) Outside sensor QAC 34
- 17) DHW production system of type BS
- 18) Primary inlet
- 19) Primary outlet

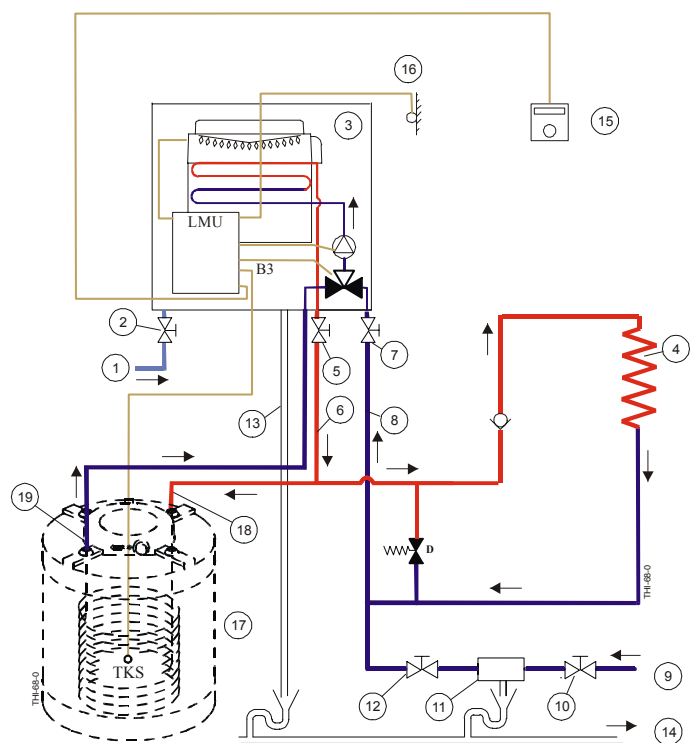

## 6 - GAS CONNECTION



**The boiler is pre-set in the factory for natural gas.**

- The inlet diameter of the boiler gas pipe is 1".
- In natural gas operational mode, a gas stopcock complying to gas regulations must be installed on the gas inlet close to the boiler and within easy access.
- Only use connections and gaskets that are approved for gas installation use.

- The gas pipe should be flushed before putting the boiler into operation. This is to evacuate any particles created by welding or fitting connections.
- Never flush the gas pipe whilst the boiler is operational (Max Gas Pressure = 100 mbar).
- The gas pipe to the boiler should not cause load losses in excess of 1 mbar (10 mmWG).  
Example: For natural gas type G20, 20 mbar for 10 metres of piping and 4 bends: minimum diameter 20/22.

## 7 - ELECTRICAL CONNECTION

- The electrical connection and all the equipment used to make this connection must be in conformity with the codes of practise in force (according to the installation standards),
- the premises must be suitable in terms of boiler protection IP 44 (model C<sub>13</sub> - C<sub>33</sub>) - IP 24 (model - B<sub>23</sub>),

### 7.1 - Mains connection

- Electrical connection of the boiler to the mains using the supply cable.
- Power supply: 230 V - 50 Hz (single phase),
- Respect the Live-Neutral polarities,
- Earth connection compulsory.

### 7.2 - Connection of the sensors to the LMU management unit

To connect the sensors to the X10 or X11 terminal of the LMU management please refer to the connection diagram on section 7.4 - page 47 or to the sensor.



**If a fault code is displayed when fitting the sensor to the LMU management unit please refer to chapter IX - OPERATING FAULTS.**

### 7.3 - Under-floor heating safety

In compliance with the regulations, a safety system must be installed. This system must be separate from the temperature control, feature a manual reset, and must cut off the supply of heat and operate even when there is no current or motor fluid (according to the installation standards).

- Terminal X10-03: Under-floor heating safety connection (limiter) (fig. 54 - page 47),
- Terminal X3-01: Under-floor heating safety connection (manual reset) (fig. 54 - page 47).

7.4 - Wiring diagram

Fig. 54

- 1) Mains supply connection
- 2) Clip-in mains connection (option)
- 3) Fan motor 230 V~
- 4) Q (heating circulating pump)
- 5) Selector valve
- 6) Ionizing electrode
- 7) Gas unit 230 V~ / RAC
- 8) Ignition transformer 230 V~
- 9) Fan PWM signal
- 10) DHW flow detector
- 11) PWM pump
- 12) AN6 (pressure sensor)
- 13) AN4 (Flue gas sensor)
- 14) AN2 (boiler return sensor)
- 15) AN1 (boiler flow sensor)
- 16) AN5 (outside sensor)
- 17) AN3 (DHW1 sensor)
- 18) Programmable digital key (e.g. mo-dem)
- 19) Room thermostat/clock\*
- 20) Room sensor (QAA73)
- 21) Connection for clip-in OC1420 or clip-in AGU2.5xx (option)
- 22) Control module (MMI = AGU2.3xx)
- 23) Connection for clip-in AGU2.5xx (option)
- 24) Removable fuse
- 25) Q2 pump (2<sup>nd</sup> circuit clip-in)
- 26) Mixing valve motor (2<sup>nd</sup> circuit clip-in)
- 27) Flow sensor QAD36 (2<sup>nd</sup> circuit clip-in)
- 28) Q2 pump (relay clip-in)
- 29) Gas safety solenoid (relay clip-in)
- 30) Alarm (relay clip-in)
- 31) Flow sensor QAD36 (relay clip-in)
- 32) Communication bus (LPB clip-in)
- 33) Under-floor heating safety connection (limiter)
- 34) Under-floor heating connection (manual reset)
- 35) ON/OFF switch (depending on the models)

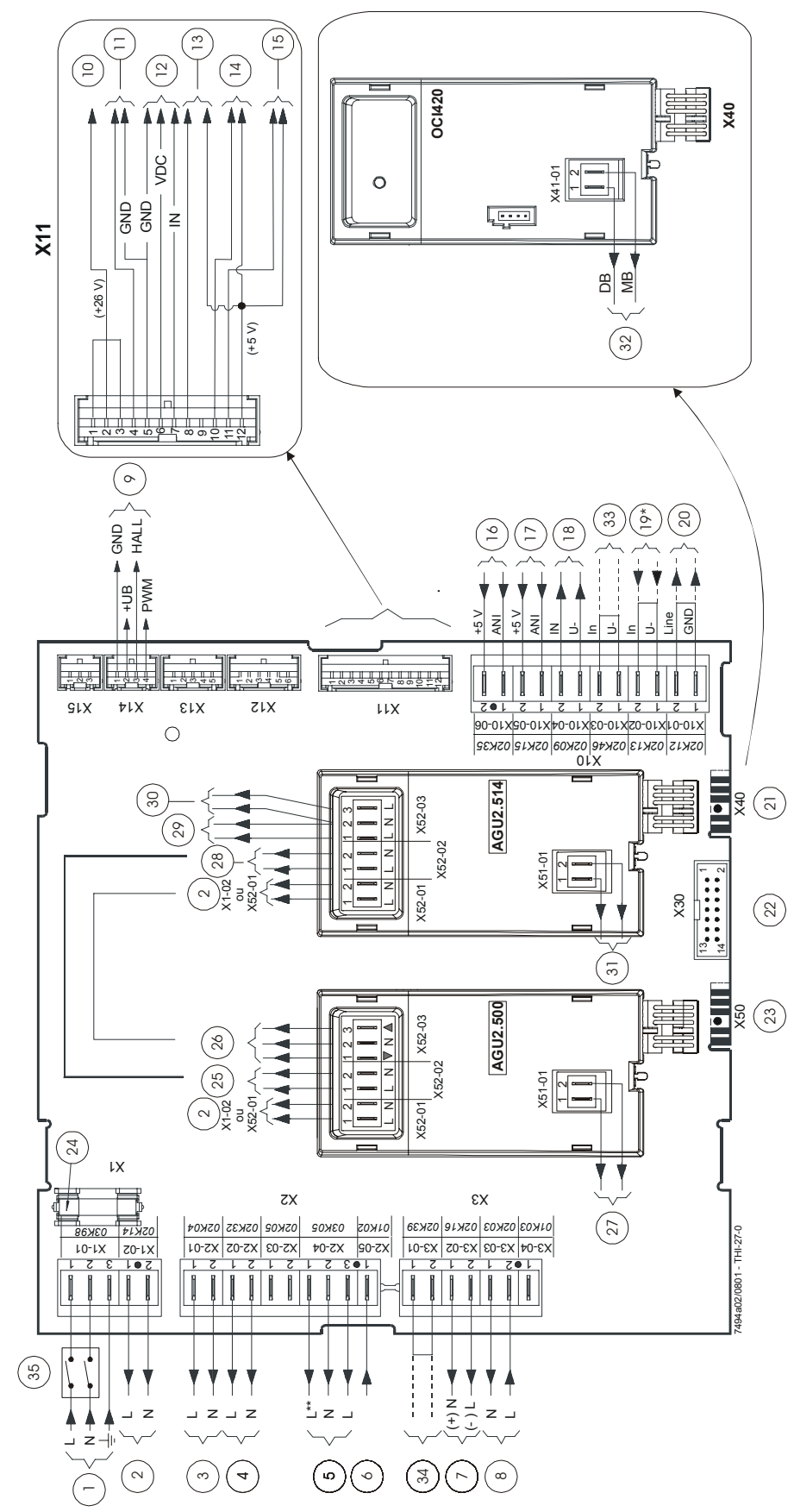



# V - SETTINGS OF THE INSTALLATION TYPES



The outside sensor is necessary and must be connected to the LMU (terminal X10-06).

The QAA 73 room sensor is required to access the settings and to adjust them (§ 3 - page 50).

The boiler's standard setup is used for the connection of:

- a Radiator circuit (CC1) controlled by the boiler's LMU,
- an Under-floor heating circuit (CC2) by using the clip-in 2nd circuit kit (the HydrSystem setting must be modified via the QAA73 - refer to table fig. 56 - page 49).

## 1 - SINGLE CIRCUIT

Fig. 55

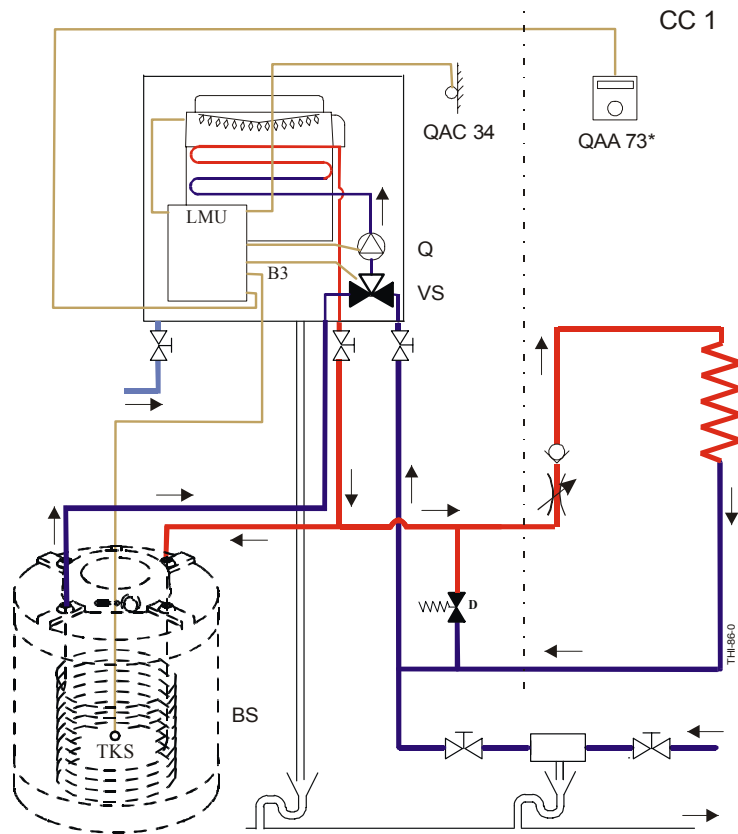

Function	FACTORY SETTINGS QAA73		QAA 73 SETTINGS TO CHANGE	
	Radiator circuit (CC1)		Under-floor heating circuit (CC1)	
	line QAA73	Value	line QAA73	Value
Slope	70	15	70	8
Tmax	72	80°C	72	50°C
Parallel shift	73	0	73	0
Room influence	75	CC1	75	CC1

Note:

- In the case of a single circuit (CC1) either a radiator circuit or an under floor heating circuit
- However if the boiler directly supplies an under floor heating circuit:
  - The QAA 73 settings need changing in accordance with the table above.

- For recommendations refer to section § 5.3 - page 42 - chapter IV - INSTALLATION.

### Necessary accessories

Accessories list	Reference
A room temperature sensor (QAA 73)	REG 73

2 - DOUBLE CIRCUIT



The double circuit function is not compatible with the modulator pump option.

If a double circuit installation is to be used with a boiler fitted with a modulator pump, it is necessary to change KonfigRg 7 parameter by the intermediary of the QAA73 room sensor (refer table fig. 56).

The radiator circuit must operate at a higher temperature than the under-floor heating circuit. The radiator circuit must be fitted with temperature controls to fine-tune the control in each room.

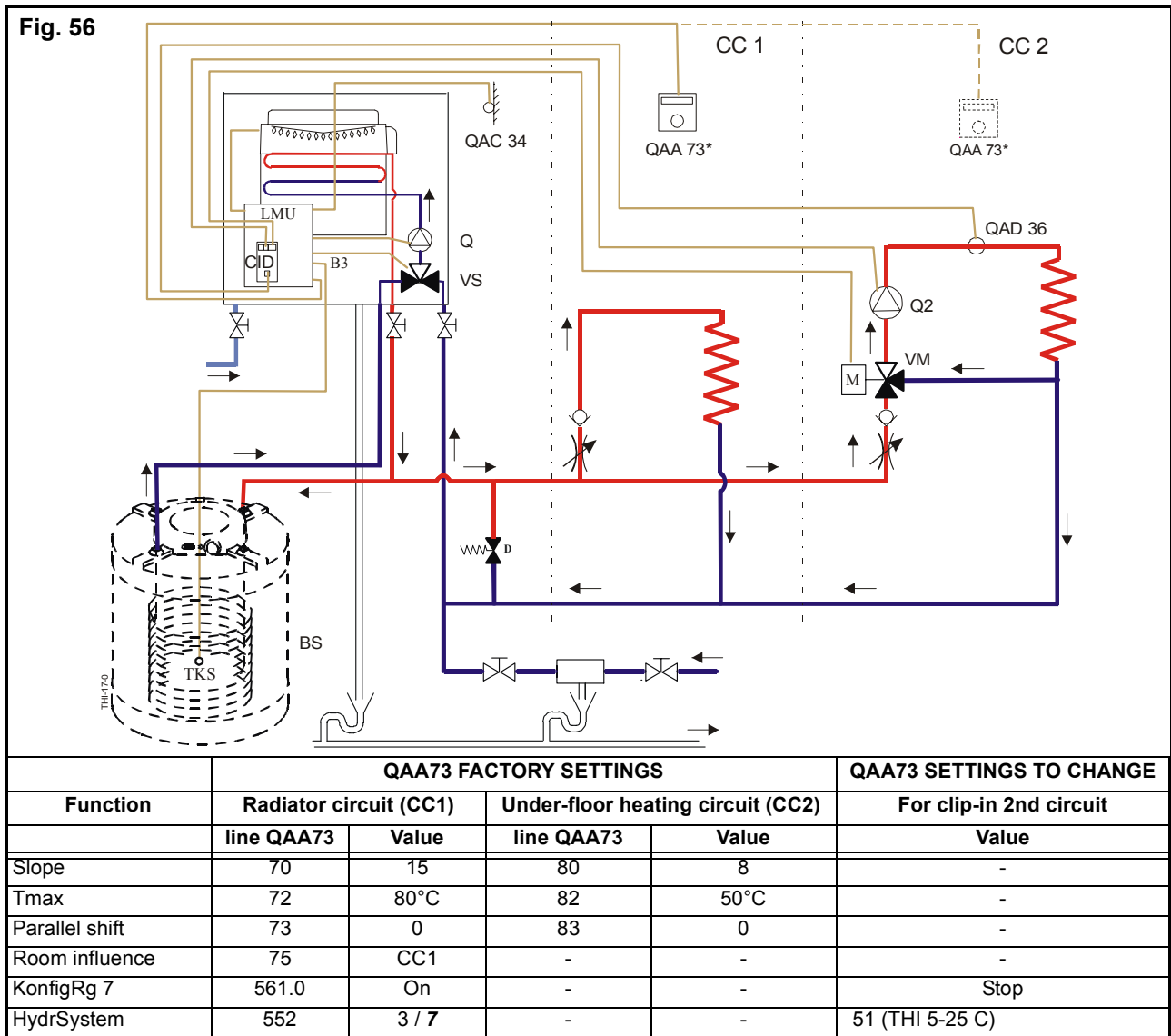

Nota :

- If the 2nd circuit (CC2) is another heating circuit, the values of the slope (8) and the temperature (50°C) must be modified via the QAA73 room sensor and brought to the standard values (slope: 15 - T max: 80°C) (refer to table above).

Necessary accessories

Accessories list	References	
A second circuit clip-in kit (CID)	REG 125	W07.30833
A mixing valve motor (M)		
A 3 ways mixing valve (VM)		
A room temperature sensor (QAA 73)	REG73	REG 73
A 2 <sup>nd</sup> circuit pump (Q2)	not supplied	

- Refer to their respective fitting instructions

**2.1 - Without room sensor**

The flow temperature of each circuit is defined by the heating curve for that circuit.

This temperature is corrected by using the boiler heating potentiometer (setting from 17°C to 23°C).



**Correction of the room temperature using the heating potentiometer acts on both heating circuits simultaneously.**

**2.2 - With room sensor**

Only one QAA73 room sensor can be connected to the LMU. It can control one or two circuits.

**The QAA73 room sensor is configured in the factory on the CC1 radiator circuit.**

The sensor defines the flow settings required as well as the domestic hot water temperature and sends them to the boiler control on the basis of the outside temperature, room temperature and various other parameters.

The heating and domestic hot water potentiometers are then disabled when the sensor is connected.

**3 - ACCESS THE SETTINGS VIA THE QAA 73 ROOM SENSOR**



**Initial display of the QAA 73 room sensor before the settings are entered:**

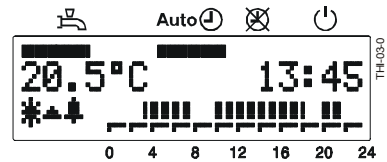







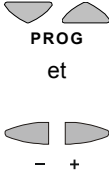

**3.1 - Access the lines 51 to 98**

	Buttons	Explanation	Line
1		Press one of the 2 line selection buttons. - This will take you to the programming mode "End-user". (1. level) Display : Note Initial language is French - go to line 47 to select English	1
2		Press both line selection buttons for at least 3 seconds. - This will take you to the programming mode "Heating engineer" (2. level) Display :	51
		<p>a) Line name b) Line number c) Setting of the parameter</p>	
3		Press the line selection buttons to select the required line.(rep. b).	51 98
4		Press the plus or minus button to enter the required value (rep. c). The setting will be stored as soon as you leave the programming mode (by pressing the Info button) or change to another line.	

3.2 - Access the lines 501 to 755

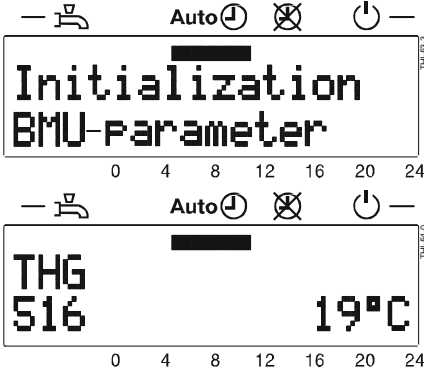

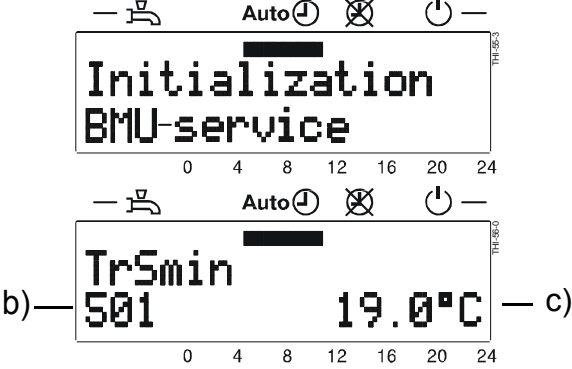
After setting the parameters via the QAA 73 room sensor, and so that the LMU accepts the modifications to the settings, press the **RESET** button on the boiler control panel, wait for 6 seconds and press a second time.

Buttons	Explanation	Line
<p>1</p> 	<p>Press on the both line selection buttons  and setting buttons  beginning with the button  - This will take you to the first programming mode "LMU"(4. level) Successive display:</p> 	<p>516</p>
<p>2</p> 	<p>Press both line selection buttons for at least 3 seconds. - This will take you to the second programming mode "LMU" (5. level) Successive display:</p> 	<p>501</p>
<p>3</p> 	<p>Press the line selection buttons to select the required line.(rep. b).</p>	<p>501 ... 755</p>
<p>4</p> 	<p>Press the plus or minus button to enter the required value (rep. c). The setting will be stored as soon as you leave the programming mode (by pressing the Info button) or change to another line.</p>	

# VI - COMMISSIONING

## 1 - PROTECTION OF THE INSTALLATION



To guarantee the boiler shell, it is recommended that only the following heating system water conditioning products are used:

- BIONIBAL corrosion inhibitor
- BIONIBAGEL antifreeze and corrosion inhibitor.

### 1.1 - Bionibal

**BIONIBAL** is a non-toxic, biocide, traceable corrosion inhibitor specially designed to protect multi-metal heating circuits.

Through its efficient means of acting against all types of corrosion and all types of bacteria, BIONIBAL:

- Prevents the formation of rust and metallic sludge,
- Prevents the formation of algae and bacteria sludge,
- Also suitable for under-floor heating systems,
- Prevents off-gases,
- Contains an internal marker so that doses can be easily controlled.

#### BIONIBAL DOSAGE:

- Without under-floor heating: 1% (0.5 l of BIONIBAL for 50 l of water).
- With under-floor heating: 2% (1 l of BIONIBAL for 50 l of water).

### 1.2 - Bionibagel

**BIONIBAGEL** is the antifreeze version of BIONIBAL.

Non-toxic antifreeze, with glycol monopropylene base, corrosion inhibitor, biocide, traceable.

In addition to the characteristics of BIONIBAL, it protects the installation from frost for residences that are not inhabited all the year round or that are in the coldest regions.

#### BIONIBAGEL DOSAGE:

The number of litres of BIONIBAGEL to put in the circuit depends on the volume of your installation and the extreme temperature of your region.

Protection limit temperature	Installation capacity (litres)			
	50	100	150	200
- 5°C	7	15	22	30
- 10°C	12	25	37	50
- 15°C	17	35	50	70
- 20°C	20	40	60	80
- 30°C	22	45	67	90

## Important warning



Bionibal or Bionibagel must only be put in a clean installation that has been checked. It is therefore imperative to fill the entire system one or more times with clean water as required. In some cases, the system may need washing by a suitable product:

#### Example:

- In a new installation: To detect any leaks and eliminate any traces of welding, weld solder or other residues.
- On an old installation: To eliminate any trace of sludge and other products in the radiators, under-floor heating system and the boiler.

## 2 - FILLING THE INSTALLATION WITH WATER

- The installation will have to be rinsed before the boiler is filled with water. Installation decantation should be provided for.
- To ensure proper boiler bleeding during the installation's filling stage:
  - Filling the DHW tank for the THI C+ BS system :
    - Fill the tank with water by using the safety control box of the installation (rep. 18, fig. 52 to fig. 53), taking care to open a hot water tap,
    - After filling, check that the tank access flap is tightened correctly.
  - Filling the installation for all models:
    - Open the heating flow/return isolation valves,
    - Open the cold water inlet valve,
    - Fill the installation slowly (to make degassing easier) by using the valve of the filling system,
    - check the leaktightness of the circuit,
    - Bleed the entire installation, particularly the radiators. Continue to fill the system until a pressure of approximately 1.5 bar is reached.
    - turn off the filling valve.

## 3 - PRESSURE SENSOR

The pressure sensor features a small window that displays the pressure status of the system without any mains supply.

Coulours	Pressure ranges
Yellow	0 to 0,5 bar
Green	0,5 to 2,5 bar
Red	2,5 to 3,6 bar

**Fig. 57**

Pressure too low = yellow

Pressure correct = green

Pressure too high = red

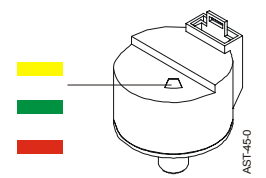

## 4 - GAS SUPPLY

- Open the gas cock (2, fig. 48 to fig. 53, IV - INSTALLATION).
- Carefully bleed the gas piping. If the installation is new, the bleed evacuates the air that is contained in the piping so that the boiler has an adequate fuel.

The presence of air in the gas prevents the ignition of the burner and leads to safety shut-down by the flame monitoring unit.

This is the case both with a natural gas and a GPL new installation. With a GPL installation the storage tank must also be bled properly before commissioning.



**The external discharge of the gas bleed must be carried out with all necessary safety measures.**

- Check the tightness of the connectors and the airtightness of the gas circuit using a foaming product or a water column pressure gauge.

## 6 - SETTING THE MAXIMUM POWER IN HEATING MODE

The maximum power of the boiler in heating mode can be limited. This operation requires modification of the PHz parameter in the boiler's LMU management unit.

Access to the PHz parameter is possible via the QAA 73 ambient temperature sensor (line 541) following the access mode defined in § 3 - page 50 - chapter V - SETTINGS OF THE INSTALLATION

TYPES.

The PHz value should be selected by following the diagram below. Adapting the boiler's maximum heating power to the maximum power of the installation helps avoid heavy loads during reheating phases and thus reduces the maximum sound output of the boiler.

**Fig. 58**

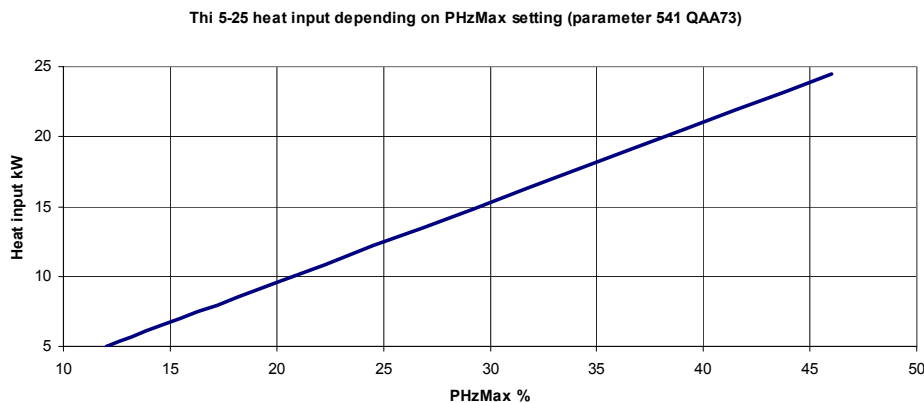

## 7 - VERIFICATIONS PRIOR TO COMMISSIONING

- Ensure that the installation has been issued with a certificate of conformity granted by an approved organisation (according to the installation standards),
  - Check that the boiler is adequately adapted to the gas used,
  - Check that the boiler is filled with water and under pressure (1.5 bar) and that there are no leaks,
- 

**Never let the pressure drop below 1 bar.**
- Check that the electrical connections of the boiler are correct: 230 V, 50 Hz, earth connection compliant, polarities correct,
  - Check that the combustion products outlet is correctly assembled, that there are no leaks and no obstruction,
  - Check that the heating system ventilations are not obstructed,
  - Check that the siphons are filled with water,
  - Check that the condensate outlet is connected properly and that there are no leaks.

## 8 - USER INFORMATION

The heating engineer must inform the user about the unit's operating mode. In particular the user must be informed about the function and the operation of the safety systems and the need for regular servicing by a qualified person.

## 9 - COMMISSIONING

- Activate the boiler's external electrical circuit-breaker,
- Press button (14) to ON " I " (depending on the models).

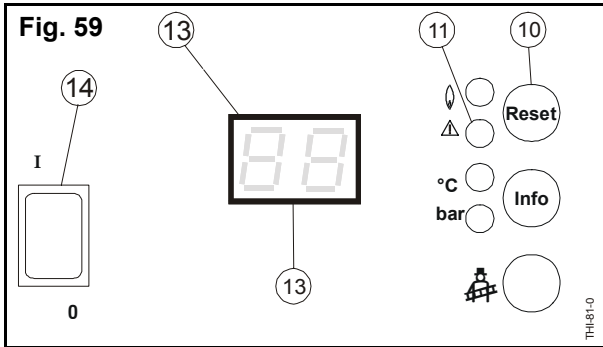

- The following references will appear one after the other on the boiler control panel display (13),

82 08 81 03

For this example, this means that it is the version 2.08 of the LMU management unit and version 1.03 of the control interface.

When starting up the boiler, the LMU management unit recognises all the accessories connected (sensors, mixing valve, pumps, etc.) and automatically checks the values and settings according to the type of installation.

If a problem occurs, the LED "alarm signal" (11) is on (red):



- Press RESET (10) to reset the boiler,
- If the alarm persists, consult the list of operating faults in Chapter IX - OPERATING FAULTS - page 63.

Display	Description	Consequences according to type of installation
<p>FUN-01-0</p>	<p>"Function" key (1) gives access to 3 operating modes by pressing:</p> <ul style="list-style-type: none"> <li>- auto mode: LED (4) on</li> <li>- winter mode: LED (5) on</li> <li>- summer mode: LED (4) and (5) off</li> </ul>	
<p>FUN-02-0</p>	<p>LED (5) on / LED (4) off: <b>Winter mode</b></p> <p>The boiler provides heating and domestic hot water</p>	<ul style="list-style-type: none"> <li>- <i>Basic boiler model (without outside sensor and room sensor)</i> <ul style="list-style-type: none"> <li>• Auto mode is inaccessible                             <ul style="list-style-type: none"> <li>. The heating and hot water temperatures are set manually by using the boiler potentiometers.</li> </ul> </li> </ul> </li> <li>- <i>Boiler with outside sensor only</i> <ul style="list-style-type: none"> <li>• Auto mode is not activated,                             <ul style="list-style-type: none"> <li>. Heating operates continually except if there is a request for hot water,</li> <li>. The hot water temperature is set manually on the boiler potentiometer.</li> </ul> </li> </ul> </li> <li>- <i>Boiler with outside sensor and room sensor</i> <ul style="list-style-type: none"> <li>• The heating and hot water temperatures are set via the room sensor QAA73.</li> </ul> </li> </ul>

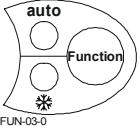
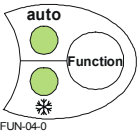
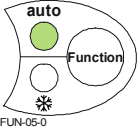

Display	Description	Consequences according to type of installation
	<p>LED (4 and 5) off: <b>Summer mode</b></p> <p>The boiler provides domestic hot water only</p>	<ul style="list-style-type: none"> <li>- <i>Basic boiler model (without outside sensor and room sensor)</i> <ul style="list-style-type: none"> <li>• Auto mode is inaccessible                             <ul style="list-style-type: none"> <li>. The hot water temperature is set manually by using the boiler potentiometers.</li> </ul> </li> </ul> </li> <li>- <i>Boiler with outside sensor only</i> <ul style="list-style-type: none"> <li>• Auto mode is not activated,                             <ul style="list-style-type: none"> <li>. The hot water temperature is set manually on the boiler potentiometer.</li> </ul> </li> </ul> </li> <li>- <i>Boiler with outside sensor and room sensor</i> <ul style="list-style-type: none"> <li>• The hot water temperature is set via the room sensor QAA73.</li> </ul> </li> </ul>
	<p>LED (4 and 5) on: <b>Auto winter mode</b></p> <p>The boiler provides heating and domestic hot water</p>	<p><b>Auto mode is active:</b></p> <ul style="list-style-type: none"> <li>- <i>Boiler with outside sensor only</i> <ul style="list-style-type: none"> <li>• The heating starts up automatically and only when the average outside temperature computed by the LMU is below 19°C.</li> <li>• The hot water temperature is set manually on the boiler potentiometer.</li> </ul> </li> <li>- <i>Boiler with outside sensor and room sensor</i> <ul style="list-style-type: none"> <li>• The heating starts up automatically and only when the average outside temperature computed by the LMU is below 19°C.</li> <li>• The heating and hot water temperatures are set via the room sensor QAA73.</li> </ul> </li> </ul>
	<p>LED (4) on / LED (5) off: <b>Auto summer mode</b></p> <p>The boiler provides domestic hot water only</p>	<p><b>Auto mode is active:</b></p> <ul style="list-style-type: none"> <li>- <i>Boiler with outside sensor only</i> <ul style="list-style-type: none"> <li>• The heating stops automatically and only when the average outside temperature computed by the LMU is below 19°C.</li> <li>• The hot water temperature is set manually on the boiler potentiometer.</li> </ul> </li> <li>- <i>Boiler with outside sensor and room sensor</i> <ul style="list-style-type: none"> <li>• The heating stops automatically and only when the average outside temperature computed by the LMU is below 19°C.</li> <li>• The hot water temperatures are set via the room sensor QAA73.</li> </ul> </li> </ul>

## 10- FLAME SETTING

- After switching the boiler on:
- Check the flame control by disconnecting the ionizing electrode:
- The boiler goes into safety mode after two ignition attempts (display  and )

## 11 - COMBUSTION PRODUCT CHECKING

- With the boiler switched on, check the combustion (CO2/CO).

Refer to Chapter VII - GAS CONVERSION - page 57.

# VII - GAS CONVERSION

Check that the boiler is properly adapted to the gas used

## 1 - SERVICE PRESSURE CONTROL

$P_i$  = Network gas pressure  
Natural gas H (G20): 20 mbar,

$P_o$  = Gas pressure at the gas valve regulator outlet.

$PL$  = Servo-system air pressure (burner-gas valve)

Fig. 60

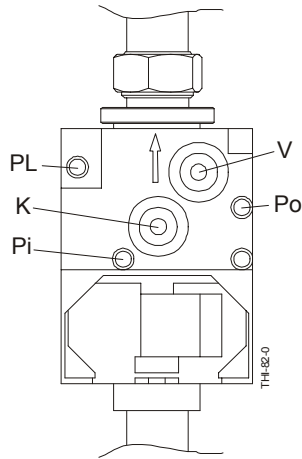

**V** = Adjust the slope of the characteristic of the air/gas ratio only when the burner **is at high rate**. This setting is carried out in the factory for natural gas type H (G20).

This means that the pressure  $P_o$  can be changed to obtain the required gas flow (section 3.2 - page 59).

**K** = Adjust the parallel shift of the characteristic only when the burner **is at low rate**. This screw is pre-set in the factory. Its setting must not be normally modified even for changing gas. If however an adjustment is required, it may be carried out with a low scale pressure gauge 0-10 mmWG, and a  $CO_2$ , CO analyser.

### 3 - GAS/CO<sub>2</sub>/CO/NO<sub>x</sub> FLOW CONTROL

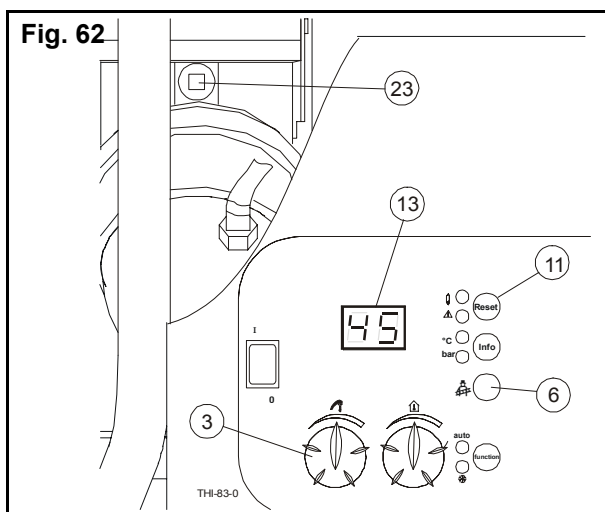

Combustion control is carried out on the boiler through the opening (23) provided for this purpose after the cap is removed. This opening must be closed again after checking.

#### 3.1 - Surveillance procedure

- To commission the burner:
  - Activate the regulator shut-down function - cleaning key (6) (Chapter III - OPERATION section. 3.11 - page 24) :

the code 88 00 flashes on the display screen (13),

- Gradually position the d.h.w. potentiometer (3) to the maximum on the right:
  - the burner switches to max. rate,
- Gradually move the **V** adjustment screw of the gas unit (fig. 60) to obtain a stable flame.
- Check the CO<sub>2</sub>/CO ratio (see setting table section 3.2 - page 59),
- Set the d.h.w. potentiometer (3) to the maximum on the left:
  - the burner switches to the minimum rate,
- Check the CO<sub>2</sub>/CO ratio (see setting table section 3.2 - page 59),
- If necessary:
  - adjust screw **K** (fig. 60) (tightening and untightening increases and decreases gas flow).



**Before starting the minimum rate setting (V and K screws), wait for a stable CO<sub>2</sub>/CO analyser read-out. Repeat switching from the minimum rate to the maximum rate several times to ensure that the setting has been done properly.**

### 3.2 - Setting table

#### 3.2.1 - Boilers pre-set in the factory for natural gas H

Models	THI			
				5-25
<b>Natural gas burner type</b>				<b>X00.18792</b>
Heat output	30/50°C 60/80°C	kW kW		5.4/25.8 4.8/23.9
Heat input		kW		5.0/24.5
Ø Gas reducer	Nat Gas H	mm		5.75
Ø Air reducer	Nat Gas H	mm		29
Gas flow (15°C, 1013 mbar)	Nat Gas H	m <sup>3</sup> /h		0.53/2.59
Gas pressure P <sub>o</sub> (gas unit to burner)	Nat Gas H	mbar		0.35/4.50
Servo-system air pressure (PL)		Pa		40/600
CO <sub>2</sub> Emission	Nat Gas H	%	8.0-8.5/9.0-9.5	
CO Emission	Nat Gas H	ppm	0/20	

- Combustion product evacuation outlet back pressure: 0 mmWG.
- P<sub>o</sub> = Gas pressure at the gas valve regulator outlet.
- PL = Servo-system air pressure (burner- gas unit).
- The P<sub>o</sub> and PL values may be more or less high according to whether back pressure is greater or smaller.

# VIII - MAINTENANCE

The annual inspection of the boiler and of the combustion product outlet is recommended. It must be carried out by a qualified person.

Spare parts must be ordered by using the references listed in chapter XII - NOMENCLATURE, and specifying the type and serial number of each part.



**Before any servicing, cut the power supply. Close the gas inlet of the boiler and the water valves if required.**

**If the boiler is removed, provide a plug at the end of the gas piping.**

## 1 - SERVICING THE FAN AND THE BURNER

Check the state of the ventilator and the burner and clean them if necessary (following their cleaning instructions).

### Disassembling the fan:

- Unscrew the four screws (1) fixing the fan (7) to the burner's air sleeve (6),
- Clean it using a domestic vacuum cleaner by placing the suction device over the air inlet and outlet successively.

### Disassembling the burner:

- Unscrew the four screws fixing (5) the burner (4) to the boiler shell (8),
- Disassemble the elbow joint (9),

- Clean the burner (4) using a domestic vacuum cleaner by placing the suction device over the air inlet and the gas inlet successively,
- Check the ignition electrodes (3) and the ionisation electrodes (2).

### During reassembly:

- Check the airtightness of the gas at the burner elbow joint/gas inlet tube level,
- check airtightness at the burner and boiler shell levels,
- following the assembly of the fan:
  - check the correct positioning of the fan/burner gasket (10),
  - check the airtightness of the gasket and replace it if necessary.

Fig. 63

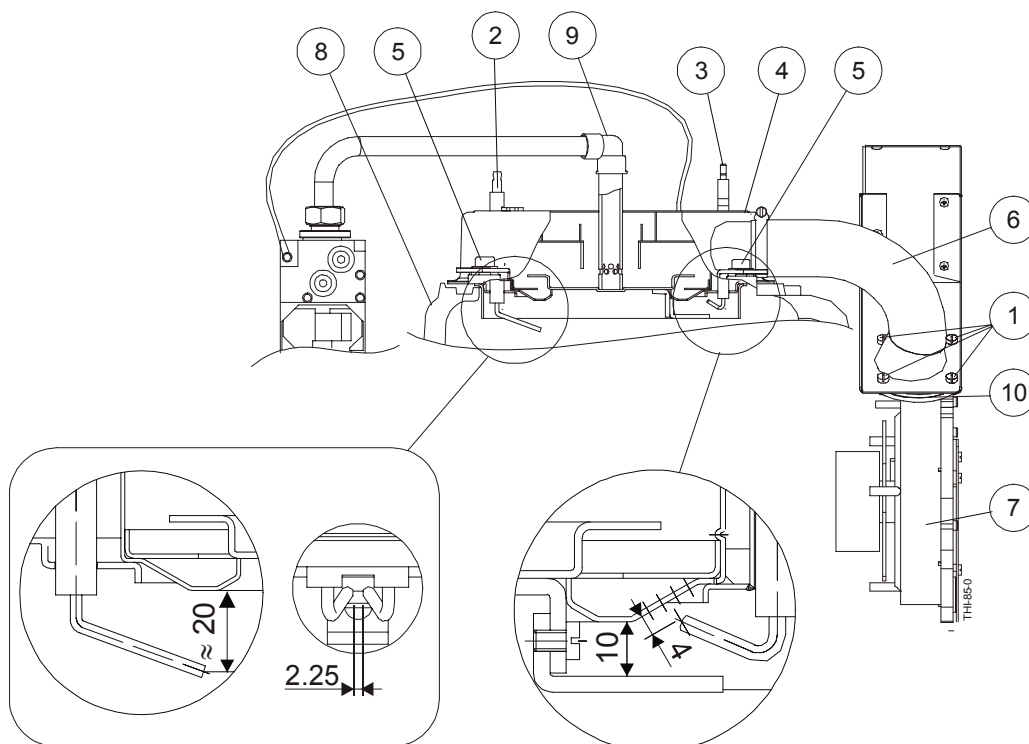

## 2 - SERVICING THE HEAT EXCHANGER OF THE BOILER SHELL

---

The heat exchanger must be cleaned once the burner has been disassembled (section 1 - page 60).

- Sprinkle the heat exchanger with water. The water is evacuated through the condensate evacuation siphon,

- when reassembling the burner onto the boiler shell check the correct positioning of the gasket.
- 

## 4 - CHECKING ACCESSORIES

---

- Check that the safety and control devices (3 bar safety valve, air bleed, safety control box, etc.) are operating properly.
- Clean the condensate drain siphon and then fill it with water.
- Also check that neither the installation nor the boiler present any water or fuel leaks (leaks may

produce a risk for safety and shorten the lifespan).

- When it is frequently necessary to add water to maintain pressure in the installation, even though no leaks have been discovered, perform an expansion vessel check (section 5 - page 61).

## 5 - EXPANSION VESSEL PRE-INFLATION PRESSURE CHECK

---

- Drop the pressure in the heating installation by opening the drain cock or the safety valve (pressure gauge reading under 0.5 bar).
- Check the pressure in the expansion vessel and if necessary bring it back up to pressure, or replace it if the membrane is punctured (water present in the inflating valve).
- To optimise the efficiency of the vessel:
  - adjust its pre-inflation pressure in line with the installation. It must correspond to the static height of the installation (H) expressed in bars

(height between the highest point of the installation and the expansion vessel, with 10 metres = 1 bar),

- adjust the filling pressure of the installation to a value of over 0.2 bar above the pre-inflation pressure of the vessel (after totally bleeding the air from the installation).

## 6 - COMBUSTION PRODUCT CONDUITS

- Check the combustion product evacuation conduit and the air inlet conduit at least once a year

(airtightness of the parts that may be disassembled - conduits not obstructed).

## 7 - DRAINING

- Cut the power supply,
- Turn off the gas cock,
- Turn off the heating flow/return valves (if they are fitted),
- Open the drain valve (rep. 18).



**Ensure that the air bleed (16) is open, as soon as the pressure gauge indicates a null pressure to allow air to enter the boiler shell.**

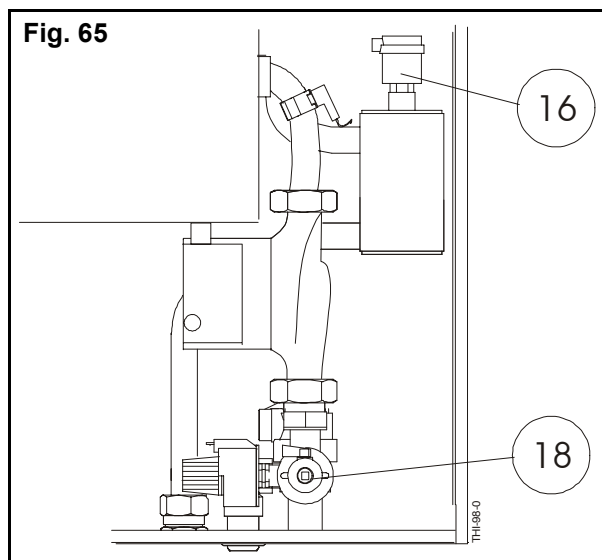

## 8 - SENSOR RESISTANCES

The resistance of the sensors must be measured after they have been disconnected from the control panel.

	Resistance values of the sensors
Temperature	Heating outlet sensor Boiler return sensor Domestic hot water sensor Flue gas sensor
0.00 °C	32624
10.00 °C	19897
15.00 °C	15711
20.00 °C	12493
25.00 °C	10000
30.00 °C	8056
40.00 °C	5324
50.00 °C	3599
60.00 °C	2483
70.00 °C	1748
80.00 °C	1252
90.00 °C	912

## IX - OPERATING FAULTS

Display	Description	Solution
10	Outside sensor fault	Check that the sensor is correctly fitted and connected
20	Boiler sensor 1 fault	Check that the sensor is correctly fitted and connected
28	Flue gas detector fault	Check that the sensor is correctly fitted and connected
32	Flow sensor 2 fault	Check that the sensor is correctly fitted and connected
40	Return sensor 1 fault	Check that the sensor is correctly fitted and connected
50	Domestic hot water sensor 1 fault	Check that the sensor is correctly fitted and connected
52	Domestic hot water sensor 2 fault	Check that the sensor is correctly fitted and connected
61	Room device 1 faulty	Check the boiler connections
62	Room device 1 error or radio clock error	Check compatibility of the room device or clock
78	Water pressure sensor fault	Increase the pressure in the circuit (if $P < 0.2$ bar), check the connections of the pressure sensor
81	Short-circuit on LPB or no voltage	Check the wiring
82	Two identical addresses on the LPB	Check the addressing
91	Loss of data in the EEPROM	Change the LMU
92	Component fault in the LMU	Change the LMU
88 00	Two master clocks (only one normally), programming problem	Check parameter 96 of the QAA73 (only one device can have the message "QAA73")
88 10	STB (boiler overheating safety) activated	Check that shunt X3-01 is present and whether the installation water flow is sufficient (circulating pump, isolation valve, etc.)
88 11	Response of the safety thermostat	Check whether the installation water flow is sufficient (circulating pump, isolation valve, etc.)
88 13	Flue gas alarm displayed (problem of the flue gas temperature being too high)	Check whether the boiler is not on thermal overload or that the exchanger is not clogged
88 17	Water pressure too high	Check and adjust the pressure level if necessary with $P < 4$ bar
88 18	Water pressure too low	Check and adjust the pressure level if necessary with $P > 0.4$ bar
88 30	Maximum flue gas temperature exceeded	Check whether the boiler is not on thermal overload or that the exchanger is not clogged



Display	Description	Solution
88 32	Safety device activated	Check that shunt X10-03 is present and that the wires are properly connected
88 33	No flame formed after the safety time period	Check that the gas reaches the boiler (Pi), check the condition of the gas valve, if there is a major adjustment fault on the gas valve, check the condition of the transformer, cables, ignition electrode, ionisation current value
88 34	Flame failure while the boiler is operating	Check and adjust the gas valve, check the ionisation electrode and the connections, possible live-neutral inversion of the transformer supply
88 40	Segment number or unauthorised addressing on LPB or LMU	Check the addressing consistency
88 48	Incompatibility between the LMU and LPB	Check the addressing consistency
88 51	New LMU configuration	The boiler must be reset when a clip-in is installed or removed.
88 52	LMU setting error	LMU setting problem
88 53	The boiler is blocked	Press Reset to clear the message
88 54	Violation of the plausibility criteria (STB related criteria)	Check the value of the criteria related to the boiler overheating security
88 60	The minimum speed threshold of the fan is not reached	Check the wiring of the fan and LMU, ensure that the fan is turning correctly
88 61	The maximum speed threshold of the fan is exceeded	Check the mains supply and the fan cable connections
88 80	The cleaning function is active	-
88 81	The regulator shut-down function is active	-
88 83	The boiler is in setting mode	This appears after one or more settings are loaded either by the QAA73 or by the PC TOOL. This means that a reset is necessary to validate the new setting(s) and for the boiler to return to normal operating.

## 1 - REAR WALL SPACER

The rear wall spacer (1) allows pipes to be fitted behind the boiler type THI ..C, in the case of installation in a vertical direction.

Fitting:

- Fit the support plate (2) (section 4 - chapter IV - INSTALLATION),
- Place the rear wall spacer (1) onto the support plate,
- Fit the boiler to the rear wall spacer.

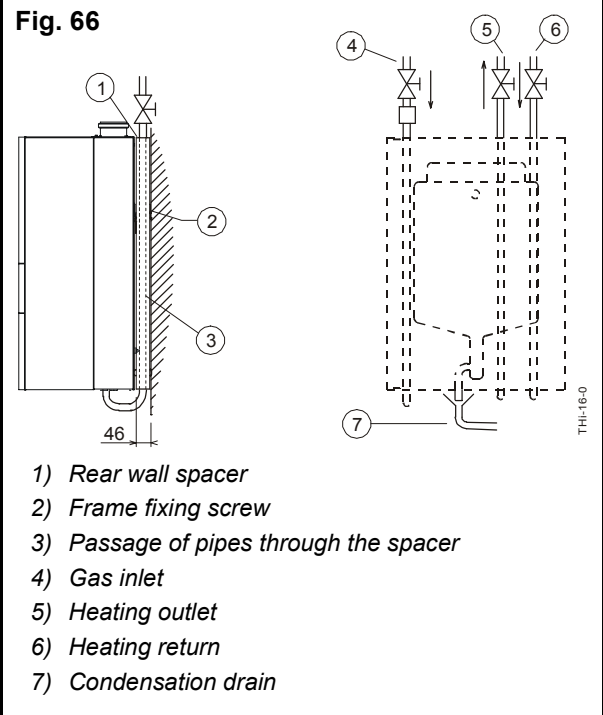

### 3 - SET-UP TAKING ROOM TEMPERATURE INTO ACCOUNT (REG 73)

The REG 73 is a multifunctional digital room sensor for one or two heating circuits and for the control of domestic hot water.

Refer to the kit installation instructions.

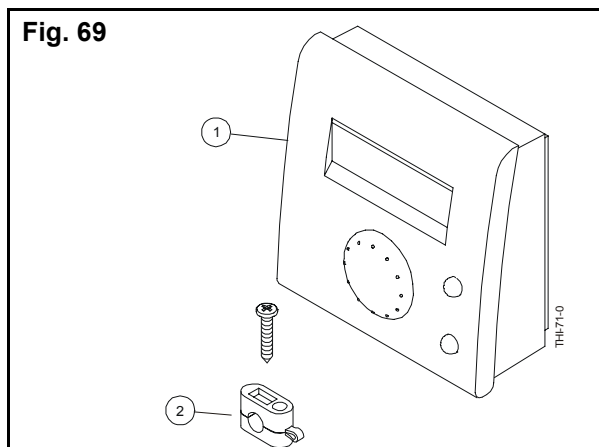

### 4 - LPB COMMUNICATION CLIP-IN KIT (REG 130)

The LPB communication clip-in kit is used to connect the LMU control unit to different units or accessories of the type:

- RVA 46: zone regulator
- RVA 47: cascade regulator
- + others (distance management etc.)

Refer to kit installation instructions.

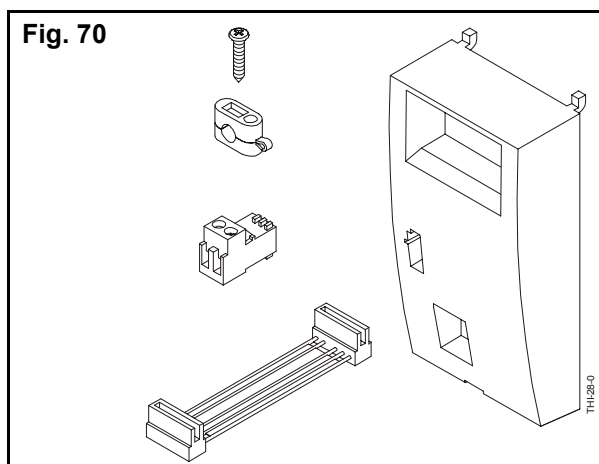

### 5 - 2ND HEATING CIRCUIT CLIP-IN KIT

The 2nd heating circuit clip-in kit is used when a second heating circuit is connected to the boiler. It allows the communication between the boiler's LMU control unit and the various accessories of the secondary circuit.

Refer to kit installation instructions.

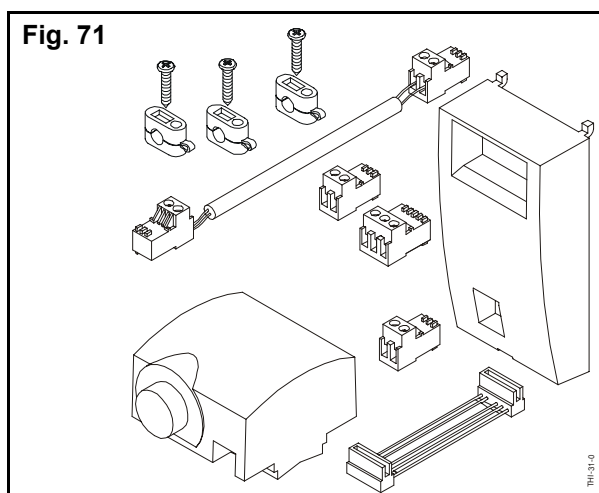

## 6 - DOUBLE CIRCUIT KIT (REG 125)

The double circuit kit is used whenever a second heating circuit is connected to the boiler:

- The 2nd circuit clip-in ensures communication between the boiler's LMU management unit; the 2nd circuit pump control and also the mixing valve motor (accessories supplied with the kit).

Refer to kit installation instructions.

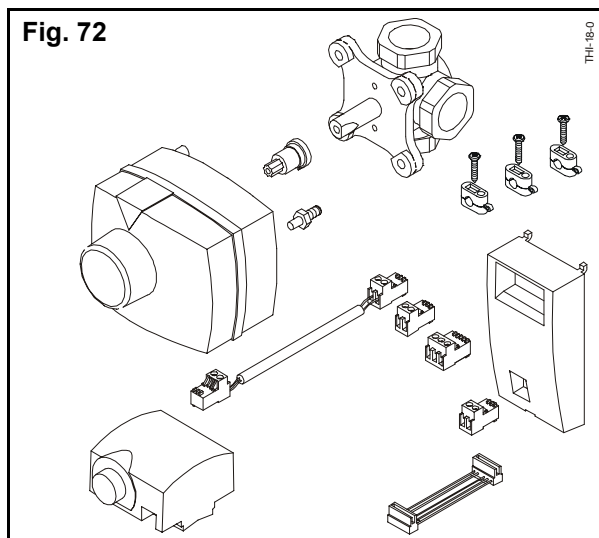

## 7 - PROGRAMMABLE RELAY CLIP-IN KIT (REG 127)

The programmable relay clip-in kit (sensor inlet)

enables:

- a 2nd heating pump to be controlled in parallel with the boiler pump in the case of operation using a header.
- with the flow sensor positioned at the outlet of the header, the heating outlet can be controlled after the header.
- an external safety gas solenoid to be connected,
- an alarm to be connected.

Refer to kit installation instructions.

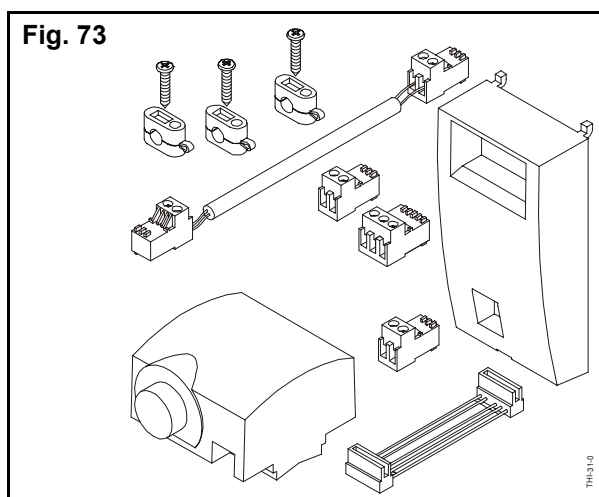

## 8 - ZHTi 46 CONTROL UNIT (REG 129)

The control unit ZHTi 46 enables an additional heating circuit to be controlled. (Required from 3 heating circuits - refer to technical specifications of the ZHTi 46).

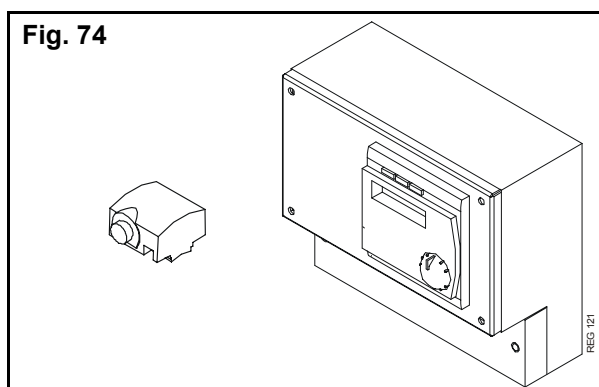

## 9 - ZHTi 47 CONTROL UNIT (REG 128)

The control unit ZHTi 47 manages 2 cascading boilers.

Note:

- For multiple boiler management, use clip-in kits LBP (130).

Refer to ZHTi 47 technical specifications.

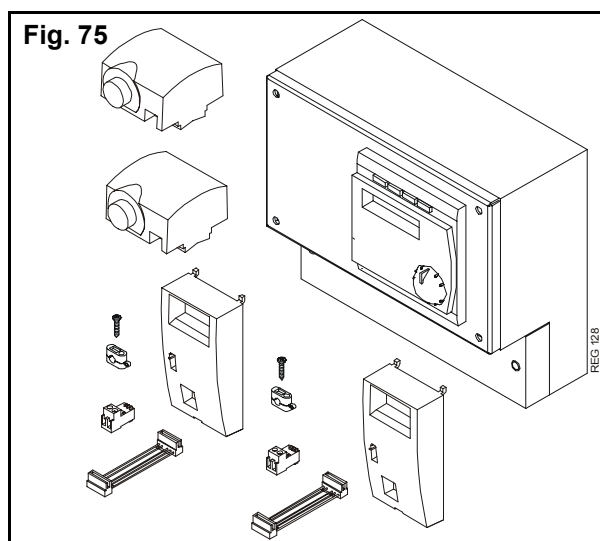

## 11 - SELECTOR VALVE KIT FOR CONNECTING THi..C/BS

The selector valve kit allows the connection of a central heating only type boiler to a domestic hot water heater.

Refer to kit installation instructions.

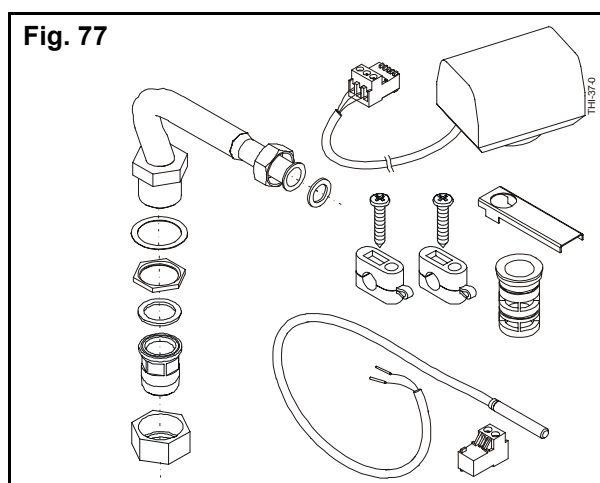

# THI 5-25 C

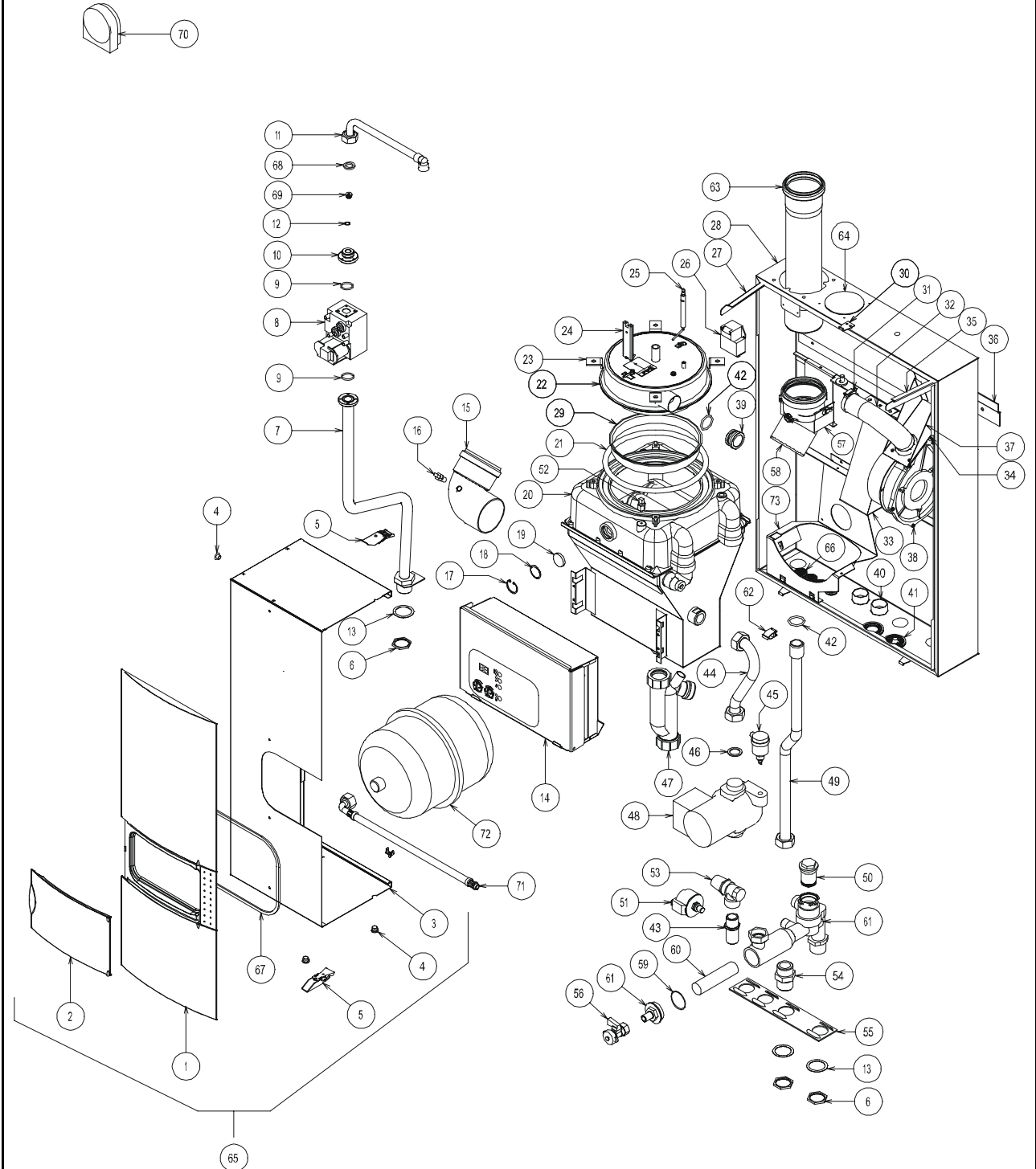

PLTIC43101

Rep.	Reference	Designation
1	H20.31463	FRONT PANEL COMPLETE
2	H20.31447	FRONT DOOR; TRANSPARENT
3	Y07.31511	WHITE MONOBLOC COVER
4	A00.28827	PLASTIC CAP MALE 1/4
5	T25.31875	FIXING PART; UPPER COVER
6	I20.21452	MESSING LOCK NUT 1
7	U07.31501	GAS SUPPLY ; GREY ; THISION
8	L10.31465	GAS VALVE VDU11.A120036 LANDIS
9	L10.10607	HONEYWELL O'RING 22 X 2,5
10	I20.24023	COUNTER FLANGE 3/4
11	U07.31527	GAS PIPE BURNER THISION
12	E00.03424	NITRILE O'RING D. 8 X 2 80 SHORE
13	V00.21491	PROTECTING RING 1
14	W07.31542	ELECTRICAL TERMINAL BOX
15	U07.31498	90° ELBOW ; D.80 DRILLED
16	L20.31496	SENSOR TASSERON NTC SENSOR D10X20 10K
17	T40.01051	INSIDE CIRCLIPS D.30 YELLOW BICHROMATE
18	B59.00692	STAINLESS STEEL WASHER 30,4X25,5X0,3
19	T20.00582	SIGHTGLASS PYREX D.30X5
20	V07.31526	STAINLESS STEEL BOILER SHELL THISION
21	F00.26572	GLASS BRAID RING D. 12 LG. 685
22	X00.18792	BURNER THR5/25 GN
22	X90.23481	BURNER SET FOR THR 5-25 LPG
23	U00.03505	FIXING BRACKET FOR BURNER MZ/THR
24	L00.16673	IGNITION ELECTRODE SHORT 74,5 AV CABLE
25	L00.12950	IONISATION PROBE (SHORT 20)
26	C90.31466	IGNITION TRANSFORMER ANSTOSS ZAG 2XV 01/10
27	Y00.18234	LEFT HAND CONSOLE (269,4X25X1,5)
28	Y07.31991	EQUIPPED FRAME THISION C
29	X00.12864	REMOVABLE PROTECTION FOR BURNER (580 X 30 X 1,5)
30	Y00.14139	FASTENING HOOK
31	B00.18392	PIPE RING 41,1/44
32	O90.16681	PIPE BURNER / FAN (THR)
33	Y00.13849	BACK STOP PLATE FOR MZ (3355X80,4X1,5)
34	Y00.17570	FLANGE FOR WHITE STAND FOR THR FAN
35	Y00.18233	RIGHT HAND CONSOLE (269,4X25X1,5)
36	V07.31962	WALL FASTENING ; C MODEL
37	Y00.17569	WHITE STAND FOR THR FAN
38	C50.31464	FAN MVL-EBM RG 128/1300-3612
39	I20.12530	AIR REDUCER D. 29
39	I20.23374	AIR REDUCER D. 27 THR 5-25 NG/LPG
40	A00.24109	ORANGE CAP D. 34,7 EZ-16
41	E20.23654	EXTENSIBLE SEALING D. 18 / RED SILICONE
42	E00.01005	O' RING DIA DIA 29,32 X 3,6
43	I20.13579	BRASS NIPPLE MAL3/4-MAL3/4(LONG)
44	U00.19252	SUMP INLET THRC/S GREY
45	L90.24635	AUTOMATIC AIR VALVE WATTS WITH ISOLATED VALVE
46	E20.03889	SEALING AFM34D 30X21X3
47	A20.23655	SIPHONIC TRAP WITH PIPE 650 MM
48	L30.31468	GRUNDFOS CIRCULATING PUMP UPER 15-50 CACAO
49	U00.19465	HEATING FLOW PIPE GREY THRC
50	H30.24159	MESSING CAP 28X52 + 2 O'RING
51	L50.31115	PRESSURE SENSOR IMIT PRP 300
52	L20.31470	SENSOR TASSERON NTC SENSOR M5 TSA-TYPE
53	L90.24178	SAFETY VALVE

Rep.	Reference	Designation
54	I20.21441	MESSING SEALED CONNECTION "OLIVE" 22/1
55	V00.23999	STOP PLATE FOR HEATING AND DHW
56	K50.24473	DRAIN COCK / RETURN UNIT
57	Y00.10807	FIXING SYSTEM FOR FLUE PIPE
58	U00.20366	ELBOW D. 80 45°
59	E00.24496	SEALING / O'RING INT. D. 39,45
60	L40.24495	STAINLESS STEEL FILTER / HEATING RETURN
61	U90.28983	HEATING RETURN UNIT
62	L20.31471	SENSOR T7335D1024B
63	N40.16810	REDUCED FLUE OUTLET PIPE F75/M80 L360
64	A00.19467	BLACK PLASTIC CAP MALE 75
65	Y07.31106	BOILER COVER; ASSEMBLED; C MODEL
66	C91.03071	WIRE CARRIER
67	V07.32114	RING FOR BOILER COVER L685
68	E20.03890	SEALING AFM34 D 24X17X3
69	I20.12056	REDUCER D.12 D.4,60
69	I20.31601	GAS REDUCER GAZ D.
70	W07.32303	OUTSIDE SENSOR .QAC34/101 THRI
71	O00.20679	STAINLESS STEEL FLEXIBLE PIPE MALE 1/4 WITH ELBOW
72	L90.03520	EXPANSION CYLIND, VESSEL 8L MALE 3/4
73	Y00.20593	WHITE STAND FOR EXPANSION VESSEL THR
*	C09.31469	CABLE WITH RECTIFIER VDU GAS VALVE
*	E00.10822	EPDM LIP SEAL D. 80 75 SHORE
*	E10.12503	EPDM STICKING SEAL PIPE 6/9 LENGTH 18
*	E20.24399	GASKET DN 80; BLACK POUR LES RÉFÉRENCES (U00.12053) ET (U00.20366)
*	I30.31973	STOP TECHNYL D.20X19
*	U00.08190	VERSILIC PIPE 6X10 LENGTH 800MM
*	U00.11405	VERSILIC SLEEVE 4X8 LENGTH 640
*	V00.24191	MOUNTING KEY; HONEYWELL
*	X00.05193	FIXING BRACKET FOR IONISATION PROBE
*	X90.30472	IGNITION ANGLE WITH SCREW



# CONTROL BOX

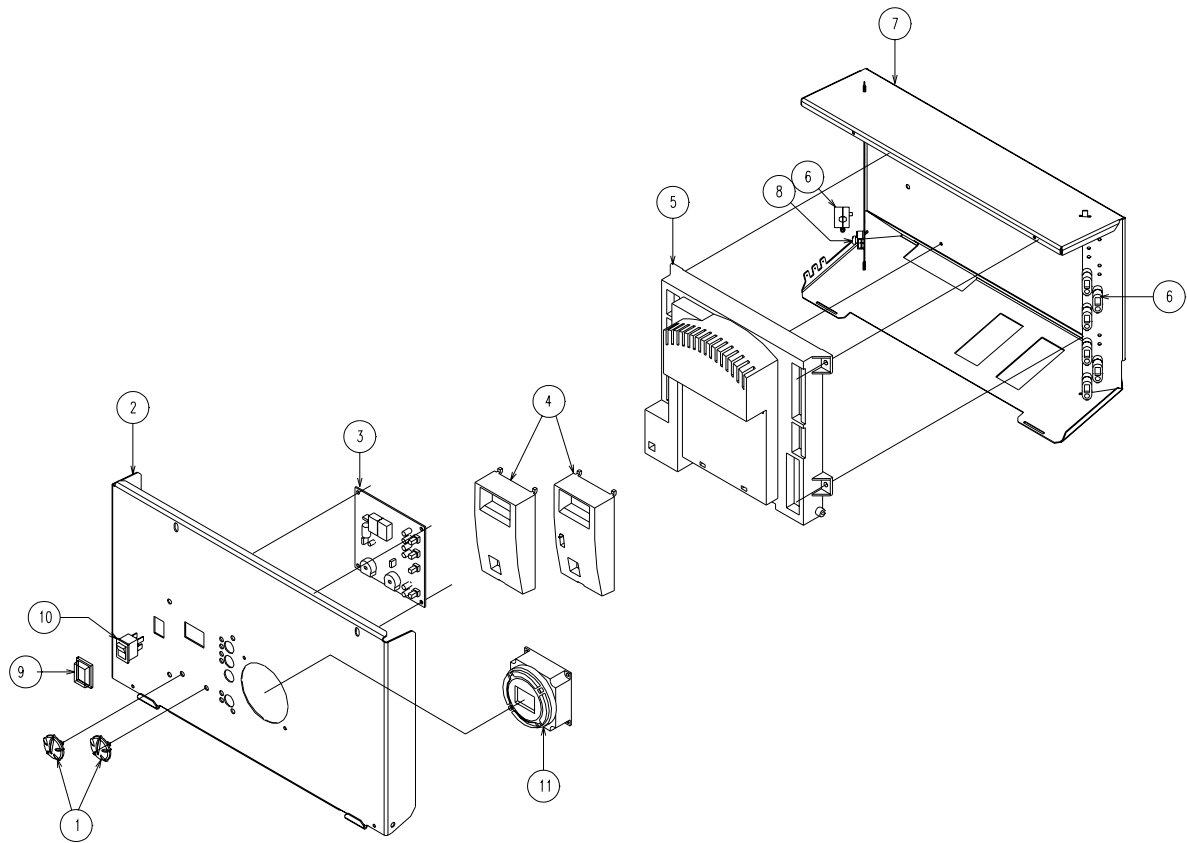

PLW0731542

Rep.	Reference	Designation
1	H20.31449	CONTROL BUTTON
2	Y07.31525	CONTROL PANEL + STICKER
3	W07.31892	INTERFACE; EQUIPPED; AGU2.303A136
4	L20.31476	COMMUNICATION MODULE CLIP-IN LPB (VOIR OPTION W07.30832)
4	L20.31477	MODULE CIRCUIT 2 CLIP-IN (VOIR OPTION W07.30833)
4	L20.31499	SUB-MODULE RELAIS CLIP-IN AGU2.511A109 (VOIR OPTION W07.30515)
5	L20.31474	ELECTRONIC CONTROL UNIT LMU64.010A136
6	A90.27098	CABLE GRIP D=6,5 MM BLACK
7	Y07.31507	ELECTR. BOX
8	C19.32006	SCREW EARTH CONNECTION
9	C20.12490	TIGHT CAP FOR SWITCH
10	C20.12486	BLACK/BLACK BIPOLAR SWITCH
11	L25.17432	TIMER GRASSLIN 230 V FM - DIGI20
*	C09.31469	CABLE WITH RECTIFIER VDU GAS VALVE
*	C90.31497	COVER KEY-TOP 4X4 THISION
*	W07.31478	WIRING OF THE CONTROL BOX
*	W07.31479	WIRING OF THE CONTROL BOX; 10-50 MODEL
*	W07.31492	CONNECTING CABLE LG LMU64/AGU2
*	W07.31508	ELECTR. CONTROL BOX + WIRING 2-13 THISION
*	W07.31542	ELECTRICAL TERMINAL BOX
*	W07.31558	ELECTR. CONTROL PANEL + WIRING 0,9-9 THISION
*	W07.31562	ELEKTR. GEHÄUSE + VERKABELUNG; 10-50C GN MODEL
*	W07.32184	CABLE FOR THE DHW CLAP ON SENSOR
*	W07.32380	CONTROL BOX ; WIRED ; PROGRAMMED THI 5-25 S DT
*	W07.32381	CONTROL BOX ; WIRED ; PROGRAMMED THI 2-13 M 75 DT
*	W07.32382	CONTROL BOX; WIRED; PROGRAMMED THI 5-25 M75 DT
*	W07.32899	CONTROL BOX ; WIRED ; PROGRAMMED THRI5-25SEP(DT)
*	W07.32995	WIRING - TIMER THRI