

The **delta** performance

PG-25/30/35/40 & 45 Gas Fired Combination Heaters

Category I or Category III
Vented Appliance



- Input from 100,000 to 199,000 Btu/hr -

* INSTALLATION AND MAINTENANCE * M A N U A L

NOTICE

Warranty Registration Card must be filled out by the customer and mailed within thirty (30) days of installation in order to gain warranty coverage.

When receiving the Delta Performance unit, any claims for damage or shortage in shipment must be filed immediately against the transportation company by the consignee.

Leave all documentation received with appliance with owner for future reference.

WARNING

If the information in this manual is not followed exactly, a fire or explosion may result causing property damage, personal injury or death.

FOR YOUR SAFETY

- Do not store or use gasoline or other flammable vapors and liquids in the vicinity of this or any other appliance.
- WHAT TO DO IF YOU SMELL GAS
 - Do not try to light any appliance
 - Do not touch any electrical switch; do not use any phone in your building.
 - Immediately call your gas supplier from a neighbor's phone. Follow the gas supplier's instructions.
 - If you cannot reach your gas supplier, call the fire department.

Installation and service must be performed by a qualified installer, service agency or the gas supplier.

PRODUCT AND SAFETY INFORMATION

Definitions 1
Product Warnings 2-3
Operating Restrictions 4
Code Restrictions 4

SECTION I - PRE-INSTALLATION ITEMS

Code Compliance 5
Determining Product Location 5
Boiler Replacement 5
Recommended Clearances 5-6
Flooring and Foundation. 6
Residential Garage Installations 6

SECTION II - COMBUSTION AIR AND VENTING

Combustion Air Contamination. 7
Combustion Air Requirements 8
Outside Combustion Air 8
Air Openings 8
Methods of Accessing Combustion Air into a Space 8-10
Vent System 10
Removal of an Existing Category I Appliance
from a Common Vent System 11

SECTION III - UNIT PREPARATION

Handling Instructions 12
Hydrostatic Pressure Test
 Hydrostatic Test Preparation 12
 Hydrostatic Test Procedures 12-13
 Completion of Hydrostatic Test and Draining 13

SECTION IV - DOMESTIC PIPING

General Piping Requirements 14
Domestic Supply Pressure 14
Thermal Expansion. 14
Water Hammer 14
Temperature / Pressure Relief Valve 14-15
Thermostatic Mixing Valve. 15

U-Tube Assembly 15-16
Domestic Drain Valve 16
Multiple Units Installation 16
Storage Tank Application 16
TR/Smart Series Application 17
Domestic Piping Diagrams 17-19

SECTION V - PRIMARY PIPING

General Piping Requirements
 Low Water Cut-off Device 20
 Backflow Preventer 20
Primary System Piping Applications 20
Expansion Tank and Makeup Water
 Diaphragm (Bladder) Expansion Tank 20
 Closed-Type (Standard) Expansion Tank 20-21
Circulator 21
Closet (Zero Clearance) Applications 21
Sizing Primary Piping 21
System Piping - Zone Circulators 21
System Piping - Zone Valves 21
System Piping - Radiant Heating with Mixing Valves 22
System Piping - Multiple Units Installation 22
Primary Piping Diagrams 23-26

SECTION VI - VENT / COMBUSTION AIR INSTALLATION

General Requirements - Category I 27
Masonry and Metal Chimneys 27
Type B Vent Systems 27
Vent Connectors 28
Common Venting - Category I 28
General Requirements - Category III 29
Category III Vent Termination - Guidelines 29
Category III Vent Termination Clearances 29-30
Multiple Vent Terminations 31
Locating the Combustion Air Inlet 31
Venting Option - Non-Direct Vent / Vertical 31
Venting Option - Direct Vent / Vertical 31-32
Venting Option - Non-Direct Vent / Horizontal 32
Venting Option - Direct Vent / Horizontal 32-33
Horizontal Wall Thimble Kit 33
Excessive Horizontal Vent Runs 33

Vent Appliance Adapters	34
Vent Condensate Drain	34
Condensate Drain Tube	34
Determining Piping Lengths	34-35
Venting Option Diagrams	35-38

SECTION VII - GAS PIPING

Gas Supply Piping Connection	39
Natural Gas	
Pipe sizing -Natural Gas	40
Natural Gas Supply Pressure Requirements	40
Propane Gas	
Pipe Sizing - Propane Gas	41
Propane Gas Supply Pressure Requirements	41

SECTION VIII - INTERNAL WIRING

General Requirements	42
Internal Control Wiring Diagrams	42-44

SECTION IX - EXTERNAL WIRING

Installation Compliance	45
Line Voltage Connections	45
Thermostat Wiring	45
Outdoor Temperature Limit	45
External Control Wiring Diagrams	46-48

SECTION X - START-UP PREPARATION

Check System and Domestic Water Chemistry	
Water pH Level 6.0 to 8.0	49
Water Hardness Less Than 7 Grains	49
Chloride Concentration Less Than 80 mg/L	49
Chlorinated Water	49
Flush Primary and Domestic System	49
Check and Test Antifreeze	49
Use of Antifreeze in the Primary System	50
Filling the Inner (Domestic) Tank and System	50
Filling the Outer (Primary) Tank and System	50-51
Check Low Water Cut-off Device	51
Check for Gas Leaks	51

Verify Correct Pressure Switch 52
Verify Correct Air Shutter Setting 52
Check Thermostat Circuit 52

SECTION XI - START-UP PROCEDURES

Final Checks Before Start-up 53
PERFORMANCE Start-up 53
If PERFORMANCE Does Not Start Correctly 53
Check the PERFORMANCE and System 53-55
Start-Up / Operating Instructions 54

SECTION XII - TEMPERATURE LIMITS

Setting Primary Thermostat Limit 56
Adjustment of Secondary Thermostat Limit 56
Setting the Thermostatic Mixing Valve 57

SECTION XIII - CHECK-OUT PROCEDURES

Check-out Procedures 58

SECTION XIV - INSTALLATION RECORD

Installation Record 59

SECTIONS XV - MAINTENANCE SCHEDULE

Service Technician - General 60
Owner Maintenance 60

SECTION XVI - MAINTENANCE PROCEDURES

Maintenance Procedures
 Reported Problems 61
 Check Surrounding Area 61
 Inspect Burner Area 61
 Check System (Primary and Domestic) Piping 61
 Check Combustion/Ventilation Air Operating 62
 Inspect Vent System and Combustion Air Piping 62
 Check Primary System 62
 Check Domestic System 62

Check Expansion Tank 62
Check Boiler Relief Valve 63
Check Temperature / Pressure Relief Valve 63
Inspection of Ignition Electrode. 63
Check Ignition Wiring and Ground Wiring 63
Check Control Wiring 63
Check Thermostat Limit Settings 63
Perform Start-Up and Checkout Procedure 63
Check Burner Flame 64
Check Flame Signal 64
Check Combustion Levels. 64
Review with Owner 64

SECTION XVII - REPLACEMENT PARTS

Replacement Parts 65-69

PRODUCT SPECIFICATIONS

Specifications 70-71

The following terms are used throughout this manual to bring attention to the presence of potential hazards or to important information concerning the product.

DANGER

Indicates the presence of a hazardous situation which, if ignored, will result in death, serious injury or substantial property damage.

NOTICE

Indicates special instructions on installation, operation or maintenance, which are important to equipment but not related to personal injury hazards.

WARNING

Indicates a potentially hazardous situation which, if ignored, can result in death, serious injury or substantial property damage.

BEST PRACTICES

Indicates recommendations made by Triangle Tube for the installers which will help to ensure optimum operation and longevity of the equipment

CAUTION

Indicates a potentially hazardous situation which, if ignored, may result in minor injury or property damage.

NOTICE

Triangle Tube reserves the right to modify the technical specifications and components of its products without prior notice.

WARNING

Bacteria can develop in the domestic water system if certain minimum water temperatures are not maintained.

DANGER

Water temperature over 125°F can cause severe burns instantly or death from scalds.

- Children, disabled and elderly are at highest risk of being scalded.
 - **Never leave them unattended in or near shower, bathtub or sink.**
 - **Never allow small children to use a hot water faucet or draw their own bath.**
- If any one using hot water in the building fits this description or codes require specific water temperatures at hot water faucet, we recommend:
 - a) ensure the factory installed thermostatic mixing valve is working properly.
 - b) to set the thermostatic mixing valve for the lowest temperature which satisfies your hot water need.

CAUTION

Protection must be taken against excessive temperature and pressure!

TO PROTECT AGAINST EXCESSIVE TEMPERATURE AND PRESSURE

- Check if the Temperature and Pressure (T&P) relief valve is in the location provided. (Domestic Water)
- Check if the 30 psi relief valve supplied is in the location provided. (Primary water)
- To avoid injury, install the relief devices to comply with local code requirements.

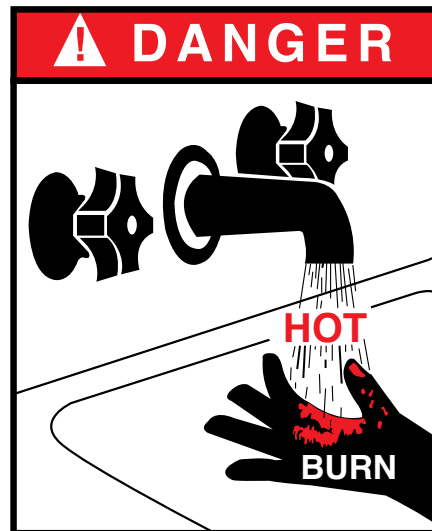

DANGER

Do not use this appliance if any part has been under water. Immediately call a qualified service technician to inspect the appliance and to replace any part of the control system which has been under water.

DANGER

WHAT TO DO IF YOU SMELL GAS

- Do not try to light any appliance
- Do not touch any electrical switch; do not use any phone in your building.
- Immediately call your gas supplier from a neighbor's phone. Follow the gas supplier's instructions.
- If you cannot reach your gas supplier, call the fire department.

Installation and service must be performed by a qualified installer, service agency or the gas supplier.

WARNING

Should overheating occur or the gas supply fails to shut off, turn OFF the manual gas control valve external to the appliance.

CAUTION

To prevent damage to inner tank, installer must:

- Fill inner tank prior to outer tank during start-up.
- Relieve primary system pressure below 15 psig prior to draining inner tank.

WARNING

Qualified Installer:

Prior to installing this product read all instructions included in this manual. Perform all installation steps required in this manual in the proper order given. Failure to adhere to the guidelines within this manual can result in severe personal injury, death or substantial property damage.

Homeowner:

- This product should be maintained / serviced and inspected annually by a qualified Service Technician.
- This manual is intended for use by a qualified Installer/Service Technician.

NOTICE

Please reference the unit's model number and the serial number from the rating label when inquiring about service or troubleshooting.

NOTICE

Triangle Tube accepts no liability for any damage resulting from incorrect installation or from the use of components or fittings not specified by Triangle Tube.

OPERATING RESTRICTIONS

- Maximum working pressure for inner (domestic water) tank is 150 psig.
- Maximum working pressure for outer (primary water) tank is 45 psig.
- Inner tank has factory installed Temperature & Pressure Relief Valve with an AGA rating of 100,000 Btu/hr for PG-25 and 200,000 Btu/hr for PG-30/35/40/45.
- Outer tank has a factory installed 30 psig relief valve rated at 535,000 Btu/hr
- Electrical rating: 120 V, 60 Hz, less than 12 amperes
- pH & chloride limits for the PERFORMANCE are:
 - Chloride, less than 80 mg/l.
 - pH, 6.0 - 8.0.

NOTICE

Any water conditioning system must be installed and maintained in accordance with manufacturer's specifications.

- 180° F Maximum operating temperature - primary side.
- 120° F Maximum outlet/mixed temperature - domestic side.

CODE RESTRICTIONS

Single wall heat exchanger in the PERFORMANCE complies with National Standard Plumbing Code, provided that:

- Outer tank water (including additives) is practically non-toxic, having toxicity rating or Class of 1, as listed in Clinical Toxicology of Commercial Products,
- Outer tank pressure is limited to maximum 30 psig by approved relief valve.

Single wall heat exchangers are permitted under the Uniform Plumbing code - Paragraph L3.2. if they satisfy all of the following requirements.

1. The heat transfer medium is potable water or contains only substances which are recognized as safe by the U.S. Food and Drug Administration.
2. The pressure of the heat transfer medium is maintained less than the normal minimum operating pressure of the potable water system
3. The equipment is permanently labeled to indicate that only additives recognized as safe by the FDA shall be used in the heat transfer medium.

Or, per Uniform Plumbing Code paragraph L3.3 as follows:

Other heat exchanger designs may be permitted where approved by the Administrative Authority.

SECTION I - Pre-Installation Items

Code Compliance

This product must be installed in accordance to the following:

- All applicable local, state, national and provincial codes, ordinances, regulations and laws.
- The National Fuel Gas Code NFPA54/ANSI Z332.1 - Latest edition.
- National Electric Code ANSI/NFPA 70.
- For installations in Canada -“Installation Code for Gas Burning Equipment” CGA/B149.

Determining Product Location

Before locating the PERFORMANCE check for convenient locations to:

- Domestic water supply piping
- Heating system piping
- Venting
- Gas supply piping
- Electrical service

Ensure the area chosen for the installation of the PERFORMANCE is free of any combustible materials, gasoline and other flammable liquids.

WARNING

Failure to remove or maintain the area free of combustible materials, gasoline and other flammable liquids or vapors can result in severe personal injury, death or substantial property damage.

Ensure the PERFORMANCE and its controls are protected from dripping or spraying water during normal operation or service.

The PERFORMANCE should be installed in a location so that any water leaking from the tank or piping connections or relief valves will not cause damage to the area surrounding the unit or any lower floors in the structure.

- When such a location is unavoidable a suitable drain pan with adequate drainage should be placed under the unit. The drain pan must not restrict the flow of combustion air to the unit.

Boiler Replacement

If the PERFORMANCE is replacing an existing boiler / hot water heater system, the following items should be checked and corrected prior to installation:

- Primary and domestic piping leaks and corrosion.
- Improper location and sizing of the expansion tank on the primary heating loop.
- Improper sizing of the thermal expansion tank (if used) on the domestic supply line.
- Vent condition and sizing.

Recommended Clearances

The PERFORMANCE is approved for zero clearance to combustibles, excluding the vent hood and vent piping.

Vent hood and vent piping - 2 inches from combustible materials unless otherwise stated by the vent pipe manufacturer.

Primary and domestic hot water piping - 1 inch from combustible material.

BEST PRACTICES

To provide serviceability to the unit it is recommended that the following clearances be maintained:

Top and vent hood area - 36 inches.

Front and burner area - 24 inches.

Rear and primary piping areas - 12 inches.

WARNING

When installing the PERFORMANCE in a confined space, sufficient air must be provided for proper combustion and venting and to allow under normal operating condition proper air flow around the product to maintain ambient temperatures within safe limits to comply with the National Fuel Gas Code NFPA 54 - latest edition.

Flooring and Foundation

The PERFORMANCE is approved for installation on combustible floors, but never on carpeting.

WARNING

Do not install the PERFORMANCE on carpeting even with a metal or wood foundation base. Fire can result causing severe personal injury, death or substantial property damage.

Installer should provide a solid brick or concrete foundation pad, at least 2 inches above the floor level if:

- There is a potential for the floor to become flooded. The height of the foundation should be such to sufficiently elevate the unit.
- The floor is dirt, sand, gravel or other loose material.
- The flooring is severely uneven or sloped.

The minimum foundation size required is 24 inches x 23 inches.

Residential Garage Installations

When installing the PERFORMANCE in a residential garage the following special precautions per NFPA 54/ANSI Z223.1 must be taken:

- Mount the unit with a minimum 18 inches above the floor level of the garage. Ensure the burner and ignition devices / controls are no less than 18 inches above the floor level.
- Locate or protect the unit in a manner so it cannot be damaged by a moving vehicle.

SECTION II - Combustion Air and Venting

Combustion Air Contamination

WARNING

If the PERFORMANCE combustion air inlet is located in any area likely to cause or contain contamination, or if products, which would contaminate the air cannot be removed, the combustion air must be repiped and terminated to an outside location. Contaminated combustion air will damage the unit and its burner system, resulting in possible severe personal injury, death or substantial property damage.

WARNING

Do not operate a PERFORMANCE if its combustion air inlet is taken inside in a laundry room or pool facility. These areas will always contain hazardous contaminants.

Pool chemicals, laundry products, common household cleaners and hobby products often contain fluorine or chlorine compounds. When these chemicals pass through the burner and vent system, they can form strong acids. These acids can create corrosion of the outer tank, burner components and vent system, causing serious damage and presenting a possible threat of flue gas spillage or water leakage into the surrounding area.

Please read the information listed below. If contaminating chemicals are located near the location of the combustion air inlet, the installer should pipe the combustion air inlet to an outside area per SECTION VI of this installation manual.

Potential contaminating products

- Spray cans containing chloro/fluorocarbons
- Permanent Wave Solutions
- Chlorinated wax
- Chlorine - based swimming pool chemicals / cleaners
- Calcium Chloride used for thawing ice
- Sodium Chloride used for water softening
- Refrigerant leaks
- Paint or varnish removers
- Hydrochloric acid / muriatic acid
- Cements and glues
- Antistatic fabric softeners used in clothes dryers
- Chlorine-type bleaches, detergents, and cleaning solvents found in household laundry rooms
- Adhesives used to fasten building products and other similar products

Areas likely to contain these products

- Dry cleaning / laundry areas and establishments
- Beauty salons
- Metal fabrication shops
- Swimming pools and health spas
- Refrigeration Repair shops
- Photo processing plants
- Auto body shops
- Plastic manufacturing plants
- Furniture refinishing areas and establishments
- New building construction
- Remodeling areas
- Garages with workshops

Combustion Air Requirements

The PERFORMANCE can use inside air if no contaminants are present in the area of installation when venting as a Category I or Category III appliance. If contaminants are likely to be present in the area of installation, outside air must be piped directly to the unit as referenced in Section VI Venting and Combustion Air Installation.

BEST PRACTICE

In order to avoid the potential of indoor contaminates when venting as either a Category I or Category III appliance it is recommended to pipe uncontaminated combustion air directly from the outdoors to the unit as referenced in Section VI Venting and Combustion Air Installation.

Outside Combustion Air

Combustion air can be ducted directly from the outside to the air inlet fitting of the PERFORMANCE (Category I or Category III vent applications) using the following materials:

- PVC
- Galvanized metal vent
- Flexible metal vent

All seams and joints must be sealed with sealant or mechanical fasteners. Do not use tape as it is not considered a sealing material.

Air Openings

Air openings to the PERFORMANCE are always required even if the combustion air is obtained indoors or outdoors. These air openings provide ventilation to prevent overheating of the PERFORMANCE and its control as well as providing combustion air.

NOTICE

The air openings must be sized to handle the requirements of all appliances and air movers (exhaust fans, etc.) contained in the same space using the same air supply.

Methods of Accessing Combustion Air Into A Space

Indoor Combustion Air

NOTICE

The methods listed in this section for accessing Indoor Combustion Air assume that the infiltration rate is adequate and not less than .40 ACH. For infiltration rates less than .40 ACH, reference the NFPA 54 National Fuel Gas Code for additional guidance.

Opening Size and Location

Openings used to connect indoor spaces shall be sized and located in accordance with the following see Fig. 1:

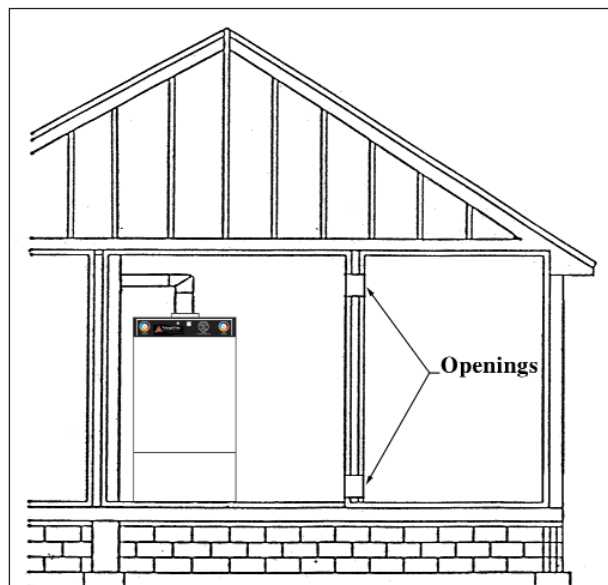

Fig. 1: Equipment Located in Confined Spaces; All Air from inside the building.

- Combining spaces on the same story. Each opening shall have a minimum free area of 1 sq. in./1000 Btu/hr of the total input rating of all gas utilization equipment in the space, but not less than 100 sq. inches. One opening shall commence within 12 inches of the top, and one opening shall commence within 12 inches of the bottom of the enclosure.
 - Combining spaces in different stories. The volumes of spaces in different stories shall be considered as communicating spaces where such spaces are connected by one or more openings in doors or floors having a total minimum free area of 2 sq. in./1000 Btu/hr of total input rating of all gas utilization equipment.
- 1sq. in./3000 Btu/hr of the total input rating of all equipment located in the enclosures, and
 - Not less than the sum of the areas of all vent connectors in the space.

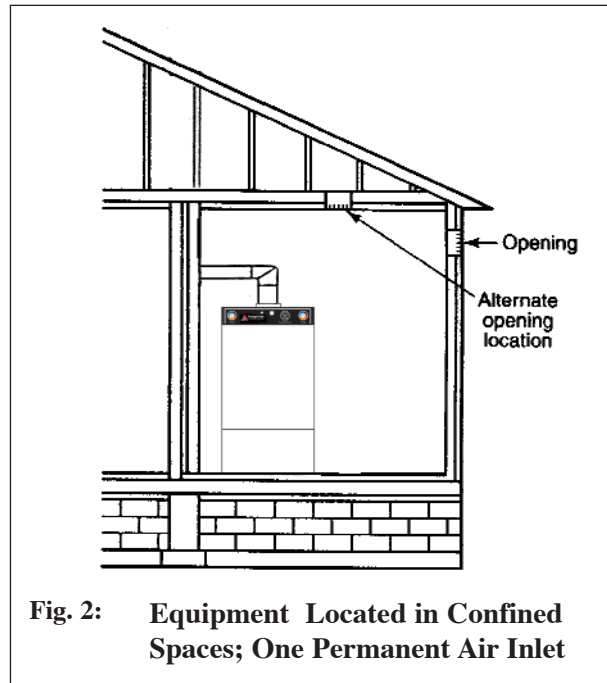

Fig. 2: Equipment Located in Confined Spaces; One Permanent Air Inlet

Outdoor Combustion Air

BEST PRACTICE

Isolating the combustion appliance room from the rest of the building and bringing in uncontaminated outside air for combustion and ventilation is always preferred.

Opening Size and Location

Openings used to supply combustion and ventilation air shall be sized and located in accordance with the following:

One Permanent Opening Method. See Fig. 2

One permanent opening, commencing within 12 in. of the top of the enclosure, shall be provided. The equipment shall have clearances of at least 1 inch from the sides and back and 6 in. from the front of the appliance. The opening shall directly communicate with the outdoors or shall communicate through a vertical or horizontal duct to the outdoors or spaces that freely communicate with the outdoors and shall have a minimum free area of the following:

Two Permanent Openings Method.

Two permanent openings, one commencing within 12 in. of the top and one commencing within 12 in. of the bottom of the enclosure, shall be provided. The openings shall communicate directly, or by ducts, with the outdoors or spaces that freely communicate with the outdoors, as follows:

- Where directly communicating with the outdoors or where communication to the outdoors is through vertical ducts, each opening shall have a minimum free area of 1 sq. in./4000 Btu/hr of total input rating of all equipment in the enclosure. See Fig.3.
- Where communicating with the outdoors is through horizontal ducts, each opening shall have a minimum free area of not less than 1 sq.in./2000 Btu/hr of total input rating of all equipment in the enclosure. See Fig. 4.

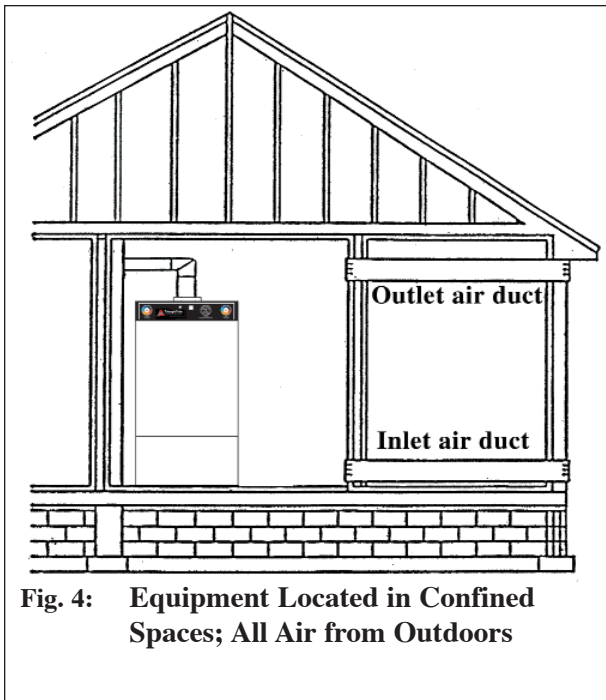
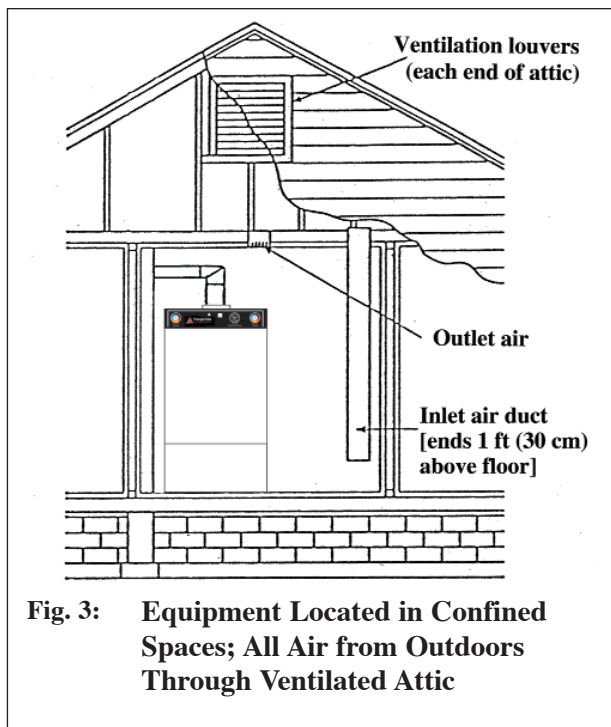

Combination of Indoor and Outdoor Combustion Air

Indoor Openings: Where used, openings connecting the interior spaces shall comply with the Indoor Combustion Air section on page 8.

Outdoor Opening(s) Location. Outdoor opening(s) shall be located in accordance with the Outdoor Combustion Air section.

Outdoor Opening(s) Size. Outdoor opening(s) shall be calculated in accordance with the following:

- The ratio of the interior spaces shall be the available volume of all communicating spaces divided by the required volume.
- The outdoor size reduction factor shall be 1 minus the ratio of interior spaces.
- The minimum size of outdoor opening(s) calculated in accordance with the above outdoor air section multiplied by the reduction factor. The minimum dimension of air openings shall not be less than 3 in.

Vent System

The PERFORMANCE is designed to vent as a Category I appliance using standard gas vent or, as a Category III appliance, which requires a special vent system.

Category III Venting is described as a vent system that has a positive static pressure and a flue temperature that avoids excessive condensate within the vent.

DANGER

Do not install the PERFORMANCE into a common vent with other gas appliances when venting as a Category III appliance. This may cause flue gas spillage or appliance malfunction, resulting in possible severe personal injury, death or substantial property damage.

Removal of an Existing Boiler from a Common Vent System

BEST PRACTICES

For installations in which the PERFORMANCE is installed as a category I Appliance and is replacing an existing boiler / hot water heater system, connected to a common vent system with other appliances, the following steps shall be conducted with each remaining appliance connected to the common venting system:

1. Any unused openings in the common venting system must be sealed.
2. A visual inspection of the venting system must be conducted for proper sizing and horizontal pitch. The inspection should ensure no blockage or restriction is within the vent system, and there is no leakage, corrosion or other items, which could cause an unsafe condition.
3. To adequately test the venting system, close all exterior doors and windows and all doors between the area containing the remaining appliances connected to the common vent system and other areas of the building. Turn on any clothes dryers and any other gas appliance not connected to the common vent system. Turn on all exhaust fans, i.e. range hoods and bathroom exhaust fans, preferably at maximum speed. Close any fireplace dampers.

4. Place in operation the first appliance being inspected that is connected to the common vent system. The remaining appliances should not be in operation. Follow the appliance's lighting instructions and adjust the thermostat to allow the appliance to operate continuously.
5. Test for spillage at the draft hood relief opening after 5 minutes of main burner operation. Spillage can be detected using the flame of a match or candle or with smoke from a cigarette.
6. Once it has been determined that each remaining appliance connected to the common vent system is properly vented, return doors, windows, exhaust fans, fireplace dampers and any operating gas appliance to their previous condition.

Should any improper operation of the common venting system be detected in the outline test, the condition should be corrected so the vent system conforms with the National Fuel Gas Code, NFPA 54/ ANSI Z223.1 - latest edition. Canadian installations must conform with B149.1 or 149.2 Installation Code.

SECTION III - Unit Preparation

Handling Instructions

The PERFORMANCE is generally easier to handle and maneuver once removed from the shipping carton and pallet.

To remove the shipping carton and pallet:

- a. Remove the shipping straps and open the top of the carton to remove the wood shipment insert.
- b. Lift the carton over the unit to remove. If ceiling height is limited, the carton maybe cut open using care not to damage the exterior jacket of the unit.
- c. Remove the front burner hood to prevent damage prior to lifting the unit from the shipping pallet.

WARNING

When lifting or moving the unit do not use the burner or its components as a means of a handle. Hand-truck the unit from the rear only.

- d. Discard all packing materials.

Hydrostatic Pressure Test

BEST PRACTICES

Prior to permanently connecting water, gas supply or electrical supply, perform a pressure hydrostatic test of the outer tank to ensure all piping connections were not damaged during shipment.

Hydrostatic Test Preparation

1. Mount the circulator on the supply pipe as shown in Figure 11 page 23.
2. Temporarily plug the primary return connections as shown in Figure 11 using a 1" NPT pipe plug. Use pipe dope sparingly to allow removal of the plugs upon completion of the test.

3. On the outlet flange of the circulator pipe install a 1" NPT nipple and shut-off valve. Use pipe dope sparingly to allow removal of the fittings upon completion of the test.

NOTICE

To avoid getting water onto the unit and/or surrounding area, additional piping from the shut-off to a catch bucket or drain may be required.

4. Connect a hose to the primary circuit drain valve located per Figure 45 page 70, Item 2 and connect the other end to a fresh water supply. Ensure the hose can be used as a drain hose upon completion of the test.

Hydrostatic Test Procedures

1. Open the shut-off valve installed on the outlet flange of the circulator.
2. Open the fresh water supply valve and then open slowly the primary circuit drain valve to fill the outer tank with water.
3. When the water within the outer tank reaches the shut-off on the primary supply, close the primary circuit drain valve.
4. Close the shut-off valve, on the top of the circulator.
5. Slowly reopen the primary circuit drain valve until the test pressure on the temperature / pressure gauge reaches **10 psig maximum**. Close the primary circuit drain valve and fresh water supply valve.

CAUTION

To prevent damage to the inner tank the test pressure must not exceed 10 psig.

6. Allow the test pressure to remain for 10 minutes.

WARNING

Do not leave the unit unattended while pressurized. A cold water fill could expand and cause excessive pressure, resulting in severe personal injury, death or substantial property damage.

7. Ensure constant gauge pressure has been maintained throughout the 10 minute test. Check for leaks at all fitting joints. Repair if found.

WARNING

Leaks must be repaired immediately when detected. Failure to repair leaks can damage the unit, resulting in substantial property damage.

8. Check continuity using a voltmeter across the terminals of the LWCO device. The contacts on the LWCO should be closed. See item 6 Figure 40 page 66 for location of the LWCO.

Completion of Hydrostatic Test and Draining

1. Disconnect the fill hose from the fresh water source and direct the hose to a suitable place of drainage.
2. Open the primary drain valve and completely drain the unit. To aid in draining open the shut-off valve on the primary supply.
3. Remove the hose from the primary drain valve when draining is complete.
4. Remove the plugs, nipple, shut-off valve and any other piping unless they will remain for use in the system piping.

SECTION IV - Domestic Piping

General Piping Requirements

- All plumbing must meet or exceed all local, state and national plumbing codes.
- Use pipe dope or tape suitable for potable water.
- Use isolation valves to isolate system components.
- Install unions for easy removal of the PERFORMANCE from the system piping.

Domestic Supply Pressure

For applications in which the domestic supply pressure exceeds **70 psig** it is recommended to install a pressure reducing valve on the cold water supply.

Maintaining the cold water supply at or below **70 psig** will prevent normal thermal expansion from repeatedly forcing the T&P relief valve open.

Thermal Expansion

If the cold water supply to the domestic inner tank contains a backflow preventer, check valve and / or a pressure reducing valve, the installer must install a domestic thermal expansion tank on the cold water supply. (See Fig. 6 page 17)

Installing a thermal expansion tank will prevent normal thermal expansion from repeatedly forcing the T&P relief valve open.

When installing a thermal expansion tank ensure the charge pressure of the tank is equal to the cold water supply pressure at the point of installation. Consult the thermal expansion tank manufacturer's instructions for further information on installation and sizing.

CAUTION

The Temperature / Pressure relief valve is not intended for constant duty, such as relief of pressure due to normal thermal expansion.

Water Hammer

Water hammer is the effect of sudden pressure changes occurring in the domestic piping. These pressure changes are typically the result of "fast acting" positive shut-off valves closing. These types of valves can be typically found on dishwashers and clothes washers.

The effects of water hammering can cause damage to system components and tank welds on the unit.

Installation of hammer arresters is recommended at these types of appliances, which incorporate "fast-acting" positive shut-off valves. Consult the manufacturer of water hammer arresters for recommendation on sizing and installation requirements.

Temperature / Pressure Relief Valve

The PERFORMANCE has a factory installed Temperature / Pressure Relief valve. Ensure the rating of the T&P relief valve is correctly sized as follows per AGA:

Model	AGA Rating
PG-25	100,000 Btu/hr
PG-30	200,000 Btu/hr
PG-35	200,000 Btu/hr
PG-40	200,000 Btu/hr
PG-45	200,000 Btu/hr

The installer must install discharge piping onto the T&P relief valve. The discharge piping must be:

- Made of material serviceable for temperatures of 250°F or greater.
- Directed so that any hot water discharge flows away from all persons.
- Directed to a suitable place of drainage.
- Installed as to allow complete draining of the T&P relief valve and the discharge piping.
- Terminated with a plain end, not with threads.

CAUTION

Failure to properly direct the discharge piping of the T&P relief valve may result in flooding of the area adjacent to the unit and or lower floors in the structure causing substantial property damage.

The installer **must not** install the T&P relief valve discharge piping in a manner that is:

- Excessively long: Using more than 2 elbows and/or 15 feet of discharge piping can reduce the discharge capacity.
- Terminated directly into a drain: The discharge piping must terminate within 6 inches of the drain. Check with local plumbing codes for termination guidelines.
- The discharge piping is plugged, reduced in size or restricted in any manner.
- The discharge piping is subject to freezing.

WARNING

DO NOT install any valves between the T&P relief valve and the discharge piping. DO NOT plug the T&P relief valve or the discharge piping. Improper placement and piping of the T&P relief valve can cause severe personal injury, death or substantial property damage.

Thermostatic Mixing Valve

The PERFORMANCE contains a factory installed thermostatic mixing valve with built-in check valve.

The operating range of the thermostatic mixing is 90°F to 120°F.

For applications with a domestic recirculation loop, the recirculation pump should be controlled by an aquastat. The maximum recommended setting of the aquastat is 10°F lower than the thermostatic mixing valve setting.

DANGER

For proper operation of the thermostatic mixing valve and to prevent potential scalding hazards, the recirculation loop should be controlled by an aquastat. DO NOT use continuous recirculation.

U-Tube Assembly

The PERFORMANCE is supplied with a U-Tube Assembly that directs cold water to the thermostatic mixing valve.

To install the U-Tube Assembly the installer must:

1. Disconnect the cold inlet adapter/union from the thermostatic mixing valve.
2. Use needle-nose pliers to remove the plastic check valve assembly from the adapter.

3. Solder the U-Tube Assembly onto the adapter. (See Fig. 5)
4. Once the adapter has sufficiently cooled, re-insert the check valve assembly making sure of orientation and reconnect onto the mixing valve.

If the installation of the PERFORMANCE requires domestic hot water for a commercial dishwasher, the installer may insert a tee connection between the unit and the mixing valve to provide 140°F domestic hot water. The installer must reference local plumbing codes to ensure if this type of application is permissible.

DANGER

The thermostatic mixing valve MUST be installed and utilized on the PERFORMANCE. Removal of the thermostatic mixing valve will result in severe personal injury or death.

CAUTION

The manual valve on the U-Tube assembly must remain in the full open position for proper operation of the thermostatic mixing valve.

Domestic Drain Valve

- The installer must install a drain valve and drain leg as shown in Fig. 6 page 17 or Fig. 7 page 18.
- The drain valve should be positioned close to the floor to aid in the siphon action required to drain the inner tank.

Multiple Units Installation

For applications using multiple units the domestic piping should be piped using a balanced manifold arrangement.

The installer should remove the thermostatic mixing valve from the units and install a single thermostatic mixing valve at the outlet of the hot water manifold. The thermostatic mixing valve should be sized according to the required flow rate and pressure drop. Refer to the thermostat mixing valve manufacturer specification and installation instructions for more details.

Reference Fig. 8, page 18 for piping diagram.

Storage Tank Application

For applications requiring large volumes of domestic hot water in a relative short period, the installer may include a storage type tank (see Fig. 9 page 19) in the domestic piping. The installer must:

1. Relocate the thermostatic mixing valve from the PERFORMANCE to the outlet of the storage tank.
2. Provide recirculation from the storage tank back to the PERFORMANCE using a bronze type circulator. Maximum recommended flow rate is 5 to 10 gpm.

NOTE

This can be accomplished through the drain connection if a 3rd tapping is unavailable and the circulator should be controlled by an aquastat.

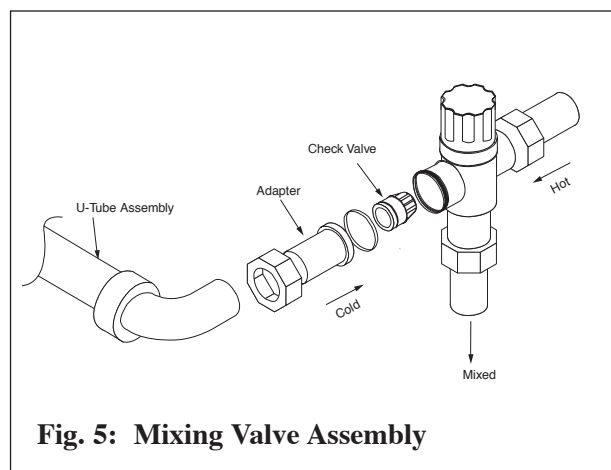

Fig. 5: Mixing Valve Assembly

TR/SMART Series Application

For applications requiring large volumes of domestic hot water over an extended period, the installer may include a Triangle Tube TR/SMART Indirect Water Heater in conjunction with the PERFORMANCE. (See Fig. 10 page 19)

The domestic system recirculation, if used, is directed to the TR/SMART Series Tank. The circulator should be controlled by an aquastat.

The primary piping to the TR/SMART Series tank must comply with the piping methods details in SECTION V - Primary Piping or with other recognized piping methods.

Additional information regarding domestic and primary piping can be found in the TR/SMART Installation Manual.

Domestic Piping Diagrams

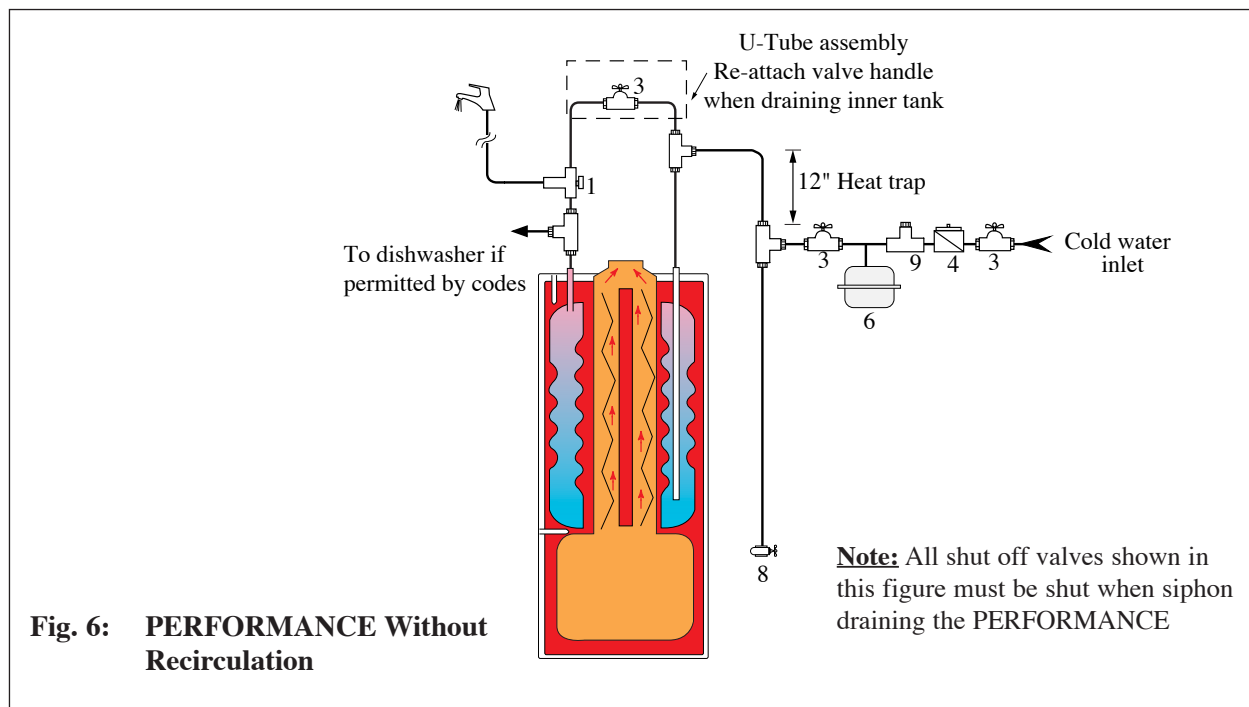
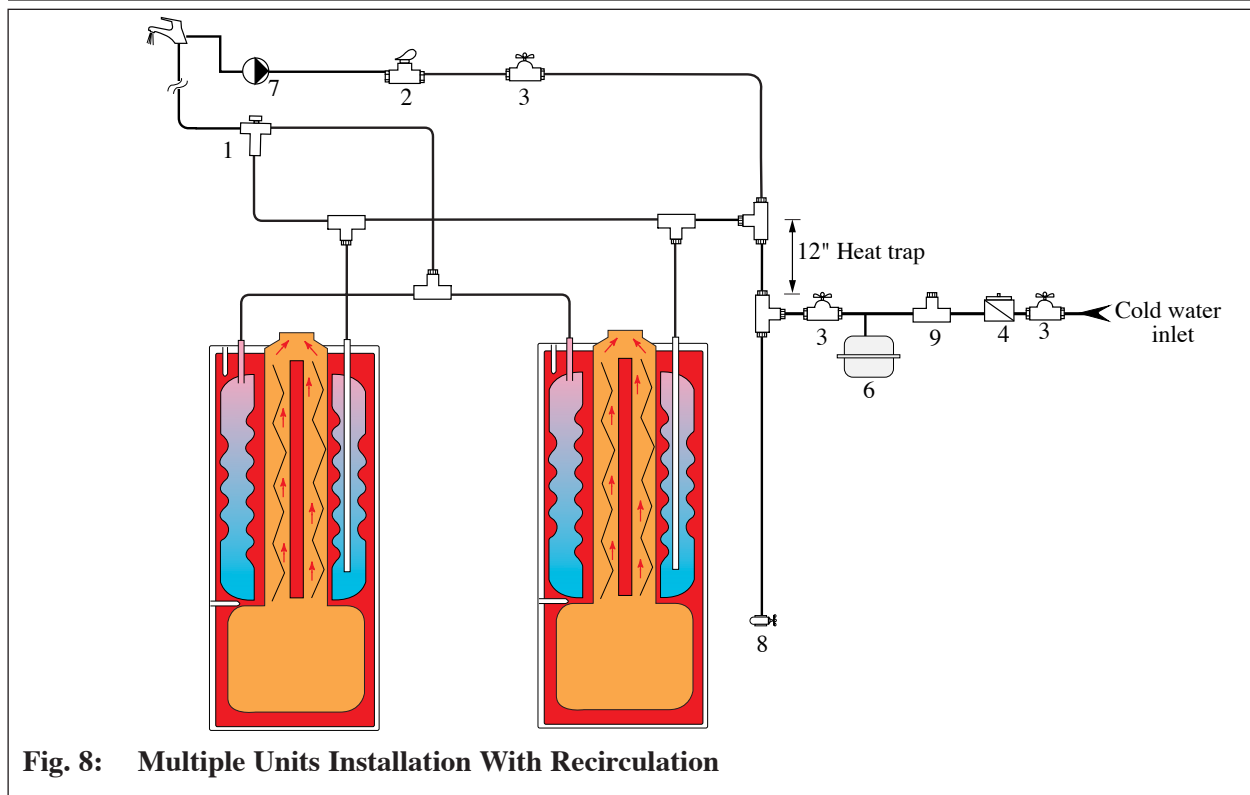
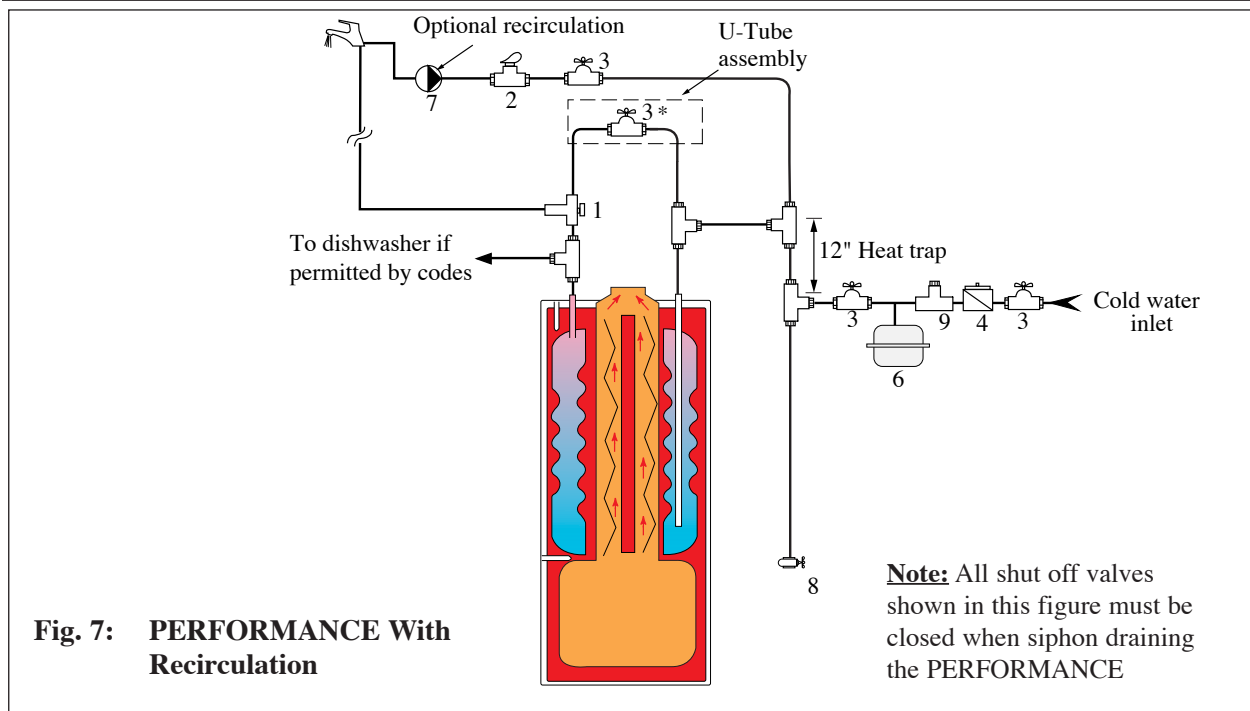

Fig. 6: PERFORMANCE Without Recirculation

- | | |
|---|---------------------------|
| 1. Mixing valve with check valve | 6. Thermal expansion tank |
| 3. Shut off valve | 8. Domestic drain valve |
| 4. Backflow preventer or pressure reducing valve* | 9. Vacuum breaker* |

* Optional devices may be required by local Codes



- | | |
|---|--|
| 1. Mixing valve with check valve | 6. Thermal expansion tank |
| 2. Flow check valve | 7. Circulator (controlled by aquastat) |
| 3. Shut off valve | 8. Domestic drain valve |
| 4. Backflow preventer or pressure reducing valve* | 9. Vacuum breaker* |

* Optional devices may be required by local Codes

Domestic Piping Diagram

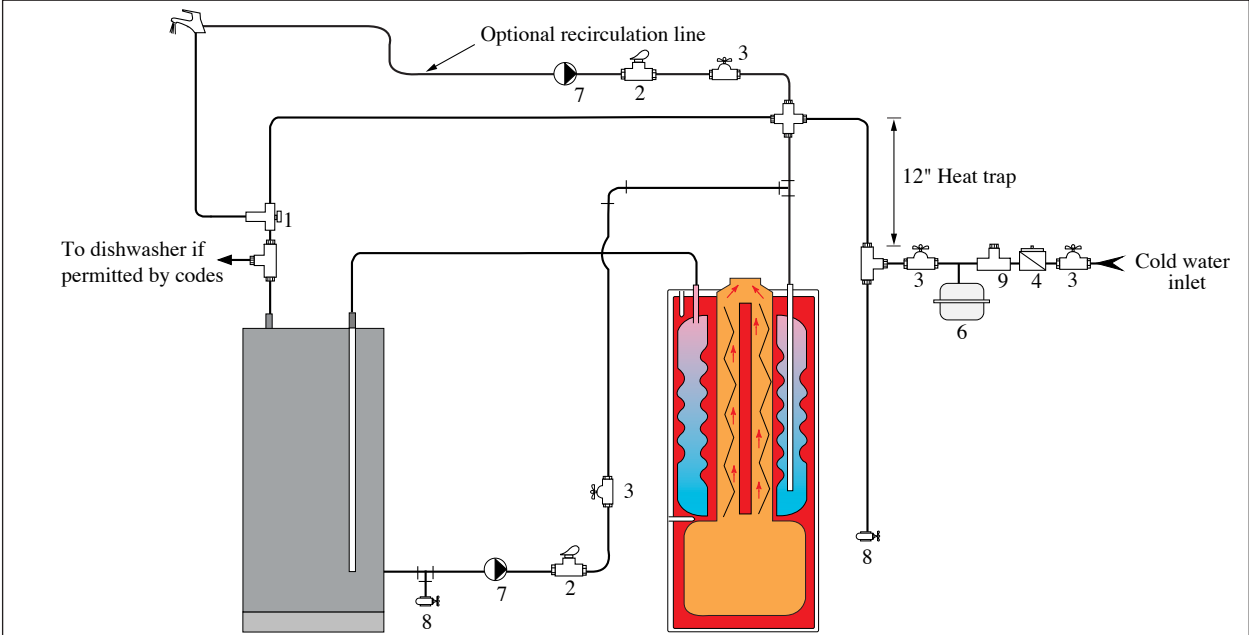

Fig. 9 : PERFORMANCE with Storage Tank

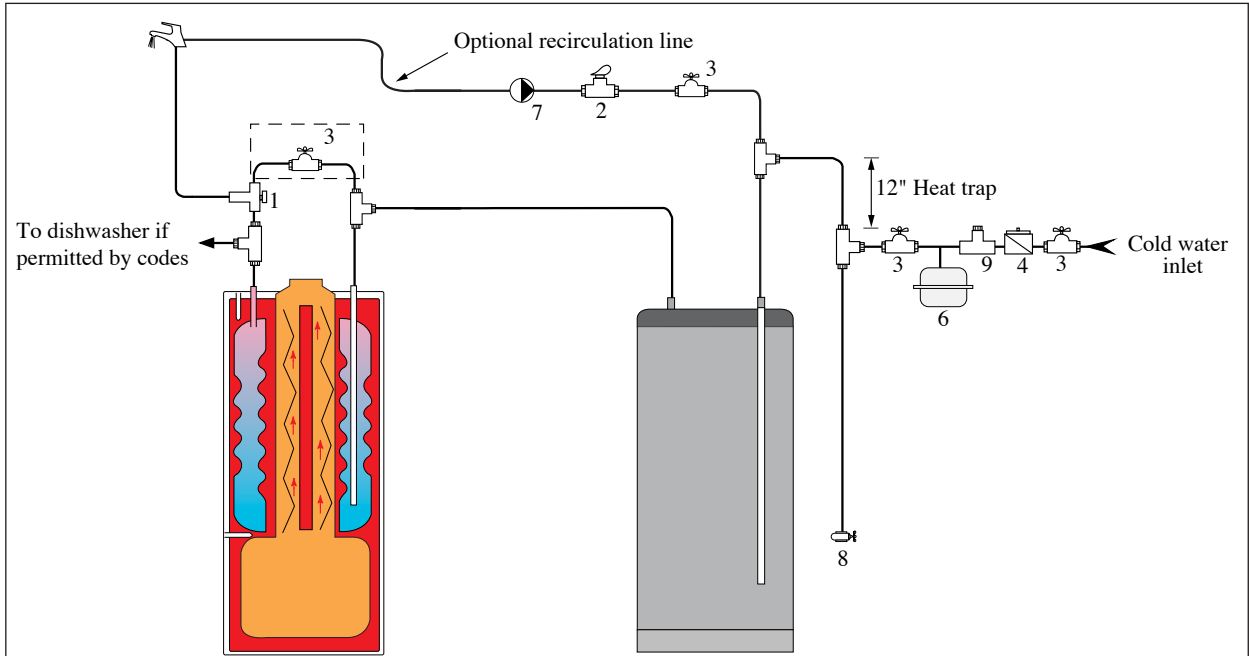

Fig. 10: PERFORMANCE with TR/SMART Indirect Water Heater

- | | |
|---|--|
| 1. Mixing valve with check valve | 6. Thermal expansion tank |
| 2. Flow check valve | 7. Circulator (controlled by aquastat) |
| 3. Shut off valve | 8. Domestic drain valve |
| 4. Backflow preventer or pressure reducing valve* | 9. Vacuum breaker* |

* Optional devices may be required by local Codes

SECTION V - Primary Piping

General Piping Requirements

Low Water Cutoff Device

- The PERFORMANCE is equipped with a factory installed pressure switch style Low Water Cut Off device.
- The minimum operating system pressure allowable with this device is 10 psig.
- Check local codes which require a low water cutoff device for compliance of this device.

Backflow Preventer

- Use a backflow preventer valve in the make-up water supply to the unit as required by local codes.

Primary System Piping Applications

BEST PRACTICE

All piping applications shown in this installation manual utilize a primary/ secondary piping arrangement. This method is recommended as a means to provide priority to the production of domestic hot water. For other piping arrangements, consult the Engineering Department at Triangle Tube or consult other approved/recognized design arrangements.

BEST PRACTICE

On piping applications utilizing a single zone or other recognized piping design arrangements, it is recommended the installer uses flow/check valves with weighted seats at or near the appliance to prevent gravity circulation.

NOTICE

To prevent potential outer tank failure, the primary system piping must be a “closed” loop sytem to avoid any oxygen contamination of the boiler water.

Expansion Tank and Makeup Water

Ensure the expansion tank is properly sized for the outer tank volume (20 gallons) and the system volume and temperature.

CAUTION

Undersized expansion tanks will cause system water to be lost through the pressure relief valve and cause additional makeup water to be added to the system. Eventual primary tank failure can result due to this excessive makeup water addition.

The expansion tank must be located as shown in Figure 11, 11A or 11B page 23 or as per recognized design methods. Refer to the expansion tank manufacturer instructions for additional installation details.

Connect the expansion tank to an air separator only if the air separator is located on the suction side (inlet) of the system circulator. Always locate and install the system fill connection at the same location as the expansion tank connection to the system.

Diaphragm (Bladder) Expansion Tank

Always install an automatic air vent on the top of the air separator to remove residual air from the system.

Closed-Type (Standard) Expansion Tank

It is recommended to pitch any horizontal piping toward the expansion tank 1 inch per 5 feet of piping. Use 3/4” piping for the expansion tank to allow air within the system to rise.

For proper operation of the expansion tank and system, remove the factory installed automatic air vent from the PERFORMANCE and plug the connection. (See Item 10, Fig. 46 page 70)

CAUTION

DO NOT install automatic air vents on a closed-type expansion tank system. Air must remain in the system and be returned to the expansion tank to provide an air cushion. An automatic air vent would cause air to be vented from the system resulting in a water-logged expansion tank.

Circulator

The PERFORMANCE is supplied with a circulator that is pre-wired to allow for domestic priority. Locate the circulator in the return or supply piping as shown in the piping diagrams included in this manual.

Closet (Zero Clearance) Applications

For applications in closets or zero clearances, the installer may use the upper primary connection shown as Item 4 on page 70 as a primary return connection. The air elimination, expansion tank and make-up water system should then be piped directly into the primary loop of the space heating prior to the system circulator.

Sizing Primary Piping

See Figs: 12 through 15, pages 24 - 25, for recommended piping arrangements based on various applications. In all diagrams, the space heating system is isolated from the PERFORMANCE using primary / secondary piping connections.

Size the piping and system components required in the space heating system using recognized design methods.

System Piping - Zone Circulators

Connect the PERFORMANCE to the system piping as shown in Fig. 12 page 24 when zoning with zone circulators. The circulator supplied with the PERFORMANCE should not be used for a heat zone. It must supply only the primary loop.

Install a separate circulator for each zone of space heating.

To control the zone circulators refer to Fig. 34, page 47.

NOTICE

To ensure adequate flow rate through the PERFORMANCE, maintain a minimum 1 inch diameter on the system piping connecting the unit to and from the primary / secondary connection.

System Piping - Zone Valves

Connect the PERFORMANCE to the system piping as shown in Fig. 13 page 24 when zoning with zone valves. The primary / secondary piping ensures the priority is given to the production of domestic hot water.

To control the system circulator refer to Fig. 33, page 46.

NOTICE

To ensure adequate flow rate through the PERFORMANCE, maintain a minimum 1 inch diameter on the system piping connecting the unit to and from the primary / secondary connection.

System Piping - Radiant Heating with Mixing Valve

Connect the PERFORMANCE to the system piping as shown with a radiant system using a thermostatic mixing valve as shown in Fig. 14 page 25. The primary / secondary piping ensures sufficient return temperature to the PERFORMANCE.

NOTICE

If the radiant system tubing contains no oxygen barrier, a stainless steel heat exchanger must be used. Failure to install a heat exchanger could lead to premature failure of the outer tank and void any warranty claim.

WARNING

Radiant heating system piping should include a means of regulating the boiler return water. The return water temperature to the unit should be maintained at 130°F or higher. Failure to prevent low return water temperature to the unit could cause premature failure of the unit and it's burner system resulting in severe personal injury, death or substantial property damage.

Size the heating system piping and circulator to provide the flow needed for the radiant system.

To control the zone circulators reference Figure 34, page 47.

NOTICE

To ensure adequate flow rate through the PERFORMANCE, maintain a minimum 1 inch diameter on the system piping connecting the unit to and from the primary / secondary connection.

System Piping - Multiple Units Installation

Use a balance manifold system as the primary / secondary connection to the space heating piping as shown in Fig. 16 page 26.

Refer to Fig. 11 page 23 to install air elimination and expansion tank.

For the space heating piping refer to the applications mentioned in this manual or use recognized design methods.

Near Appliance Piping

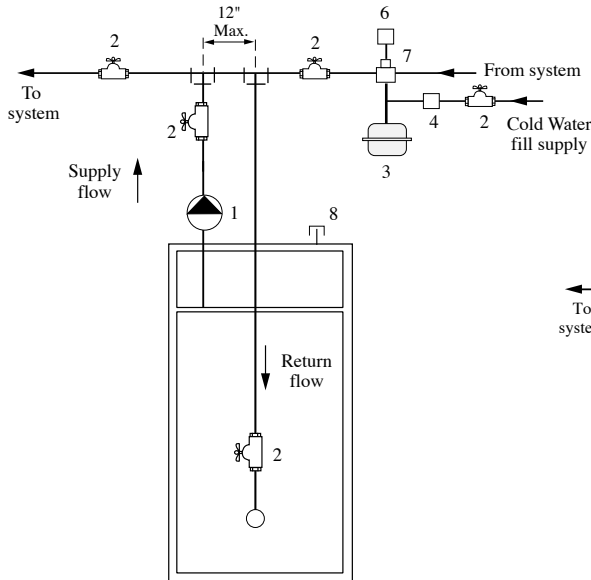

Fig. 11 : Near Appliance Primary Piping with a Diaphragm Type Expansion Tank

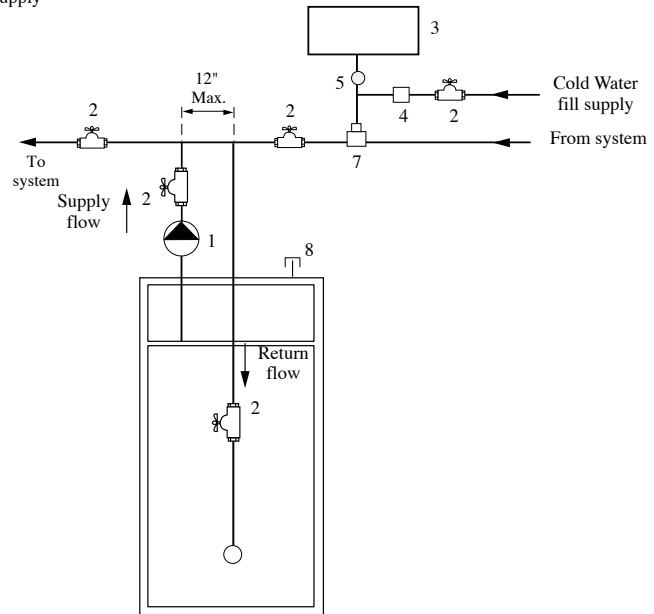

Fig. 11A : Near Appliance Primary Piping with Closed - Type Expansion Tank

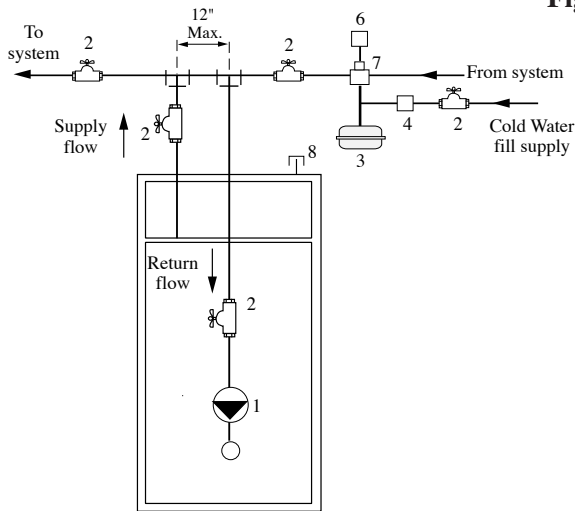

Fig. 11B : Near Appliance Primary Piping with Diaphragm - Type Expansion Tank (Alternate Circulator Location)

- | | | |
|-------------------------|-----------------------|---------------------|
| 1. Appliance Circulator | 4. Auto fill valve | 7. Air Separator |
| 2. Shut Off valve | 5. Tank fitting | 8. Plug (by others) |
| 3. Expansion tank | 6. Automatic air vent | |

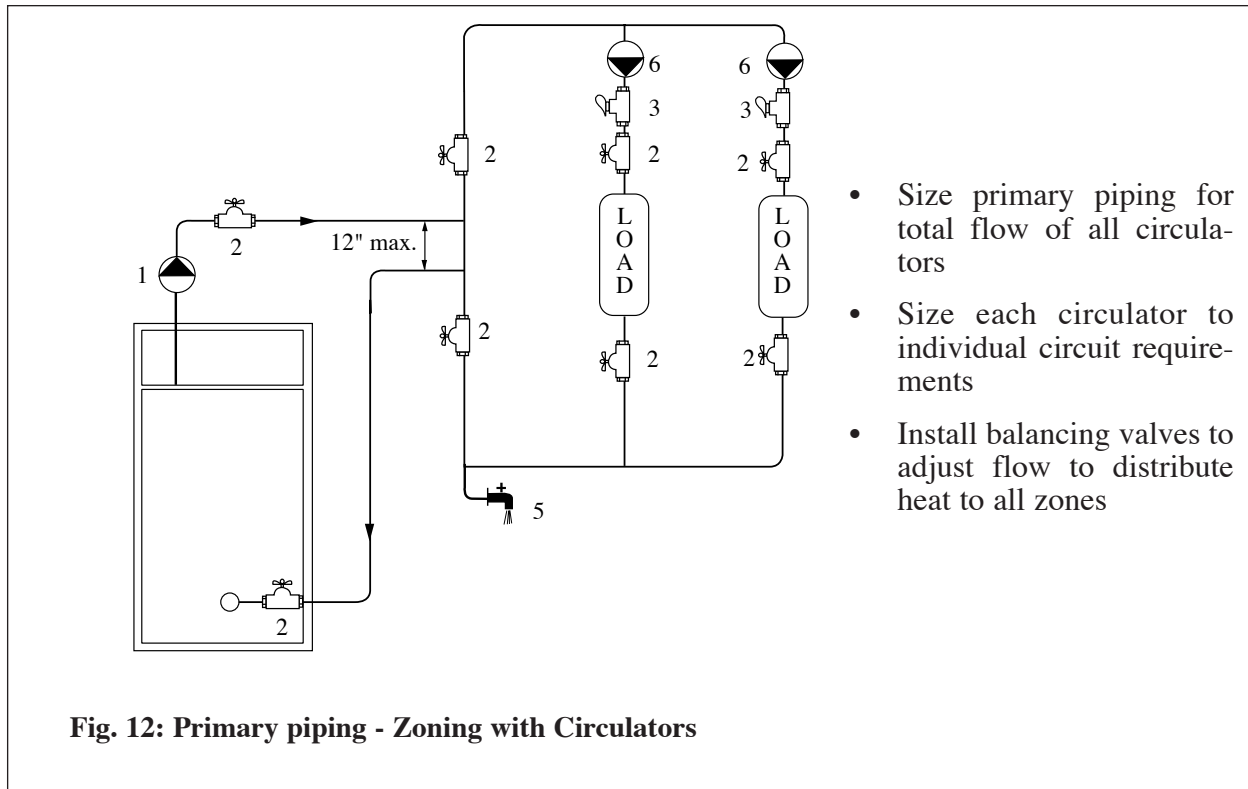

Fig. 12: Primary piping - Zoning with Circulators

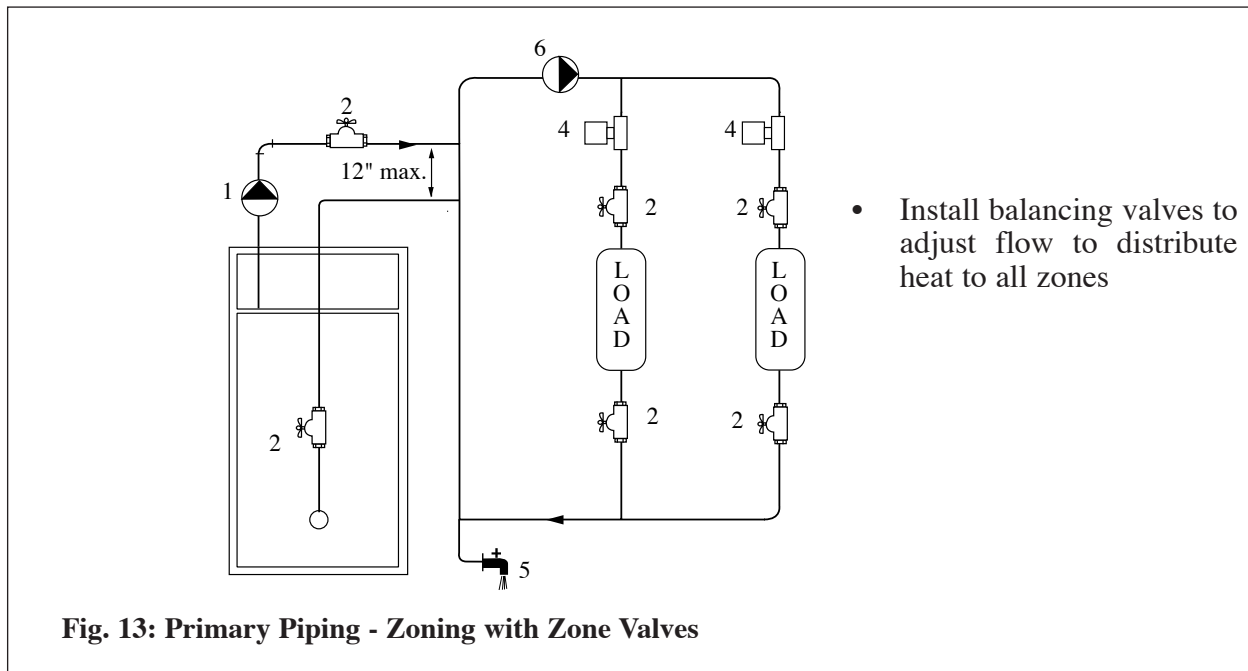

Fig. 13: Primary Piping - Zoning with Zone Valves

1. Appliance circulator
2. Shut-off valves
3. Flow check valve
4. Zone valve

5. System purge valve
6. System circulator

Note: See page 23 for near appliance piping.

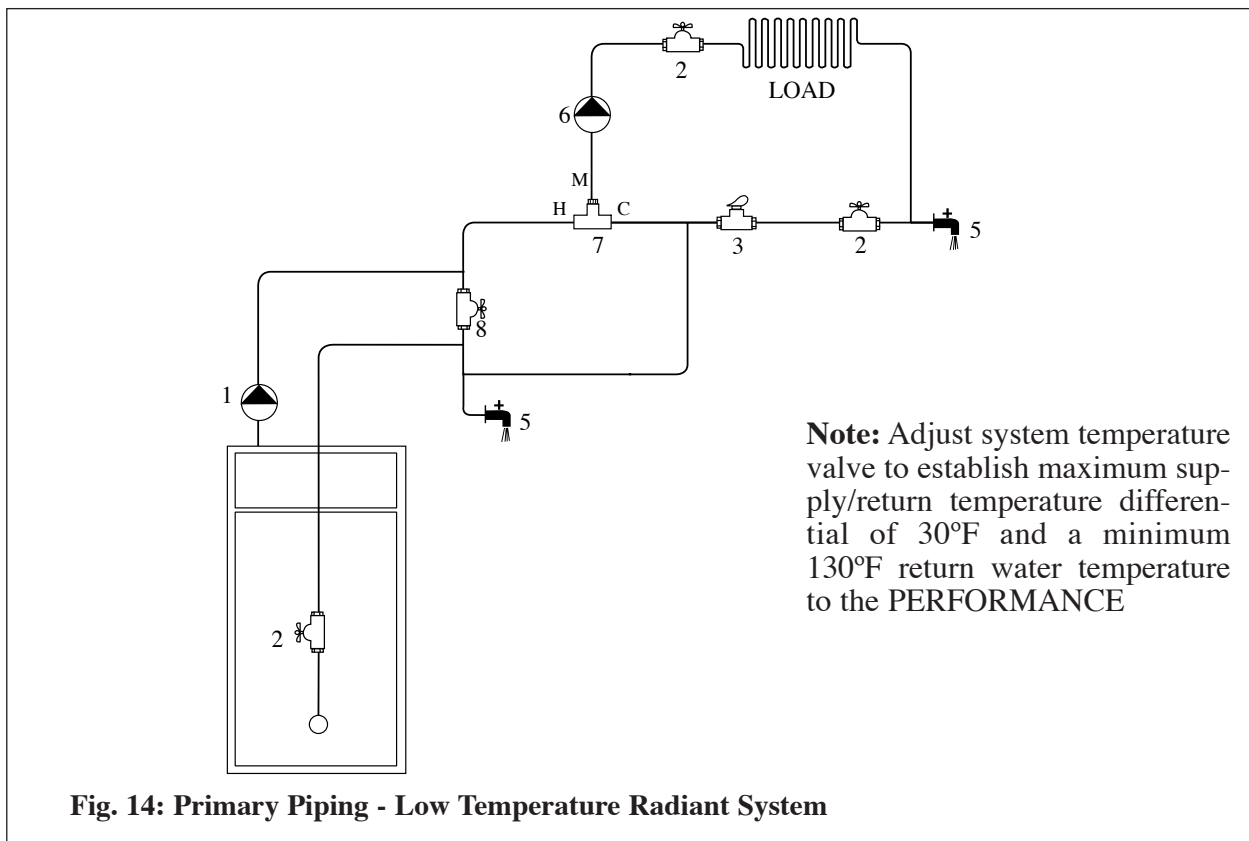

Fig. 14: Primary Piping - Low Temperature Radiant System

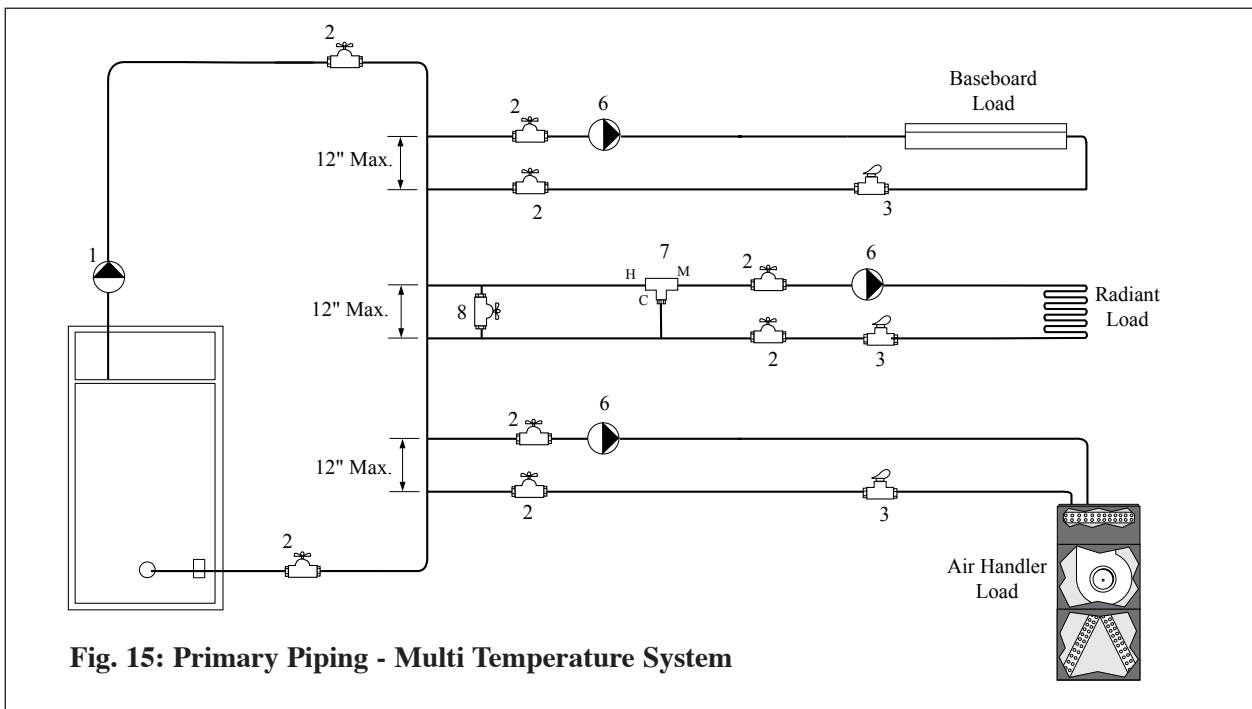

Fig. 15: Primary Piping - Multi Temperature System

- | | |
|-------------------------|--|
| 1. Appliance circulator | 5. Purge valve |
| 2. Shut Off valves | 6. System circulator |
| 3. Flow check valve | 7. 3-way mixing valve |
| 4. Zone valve | 8. System Temperature valve (See note above) |

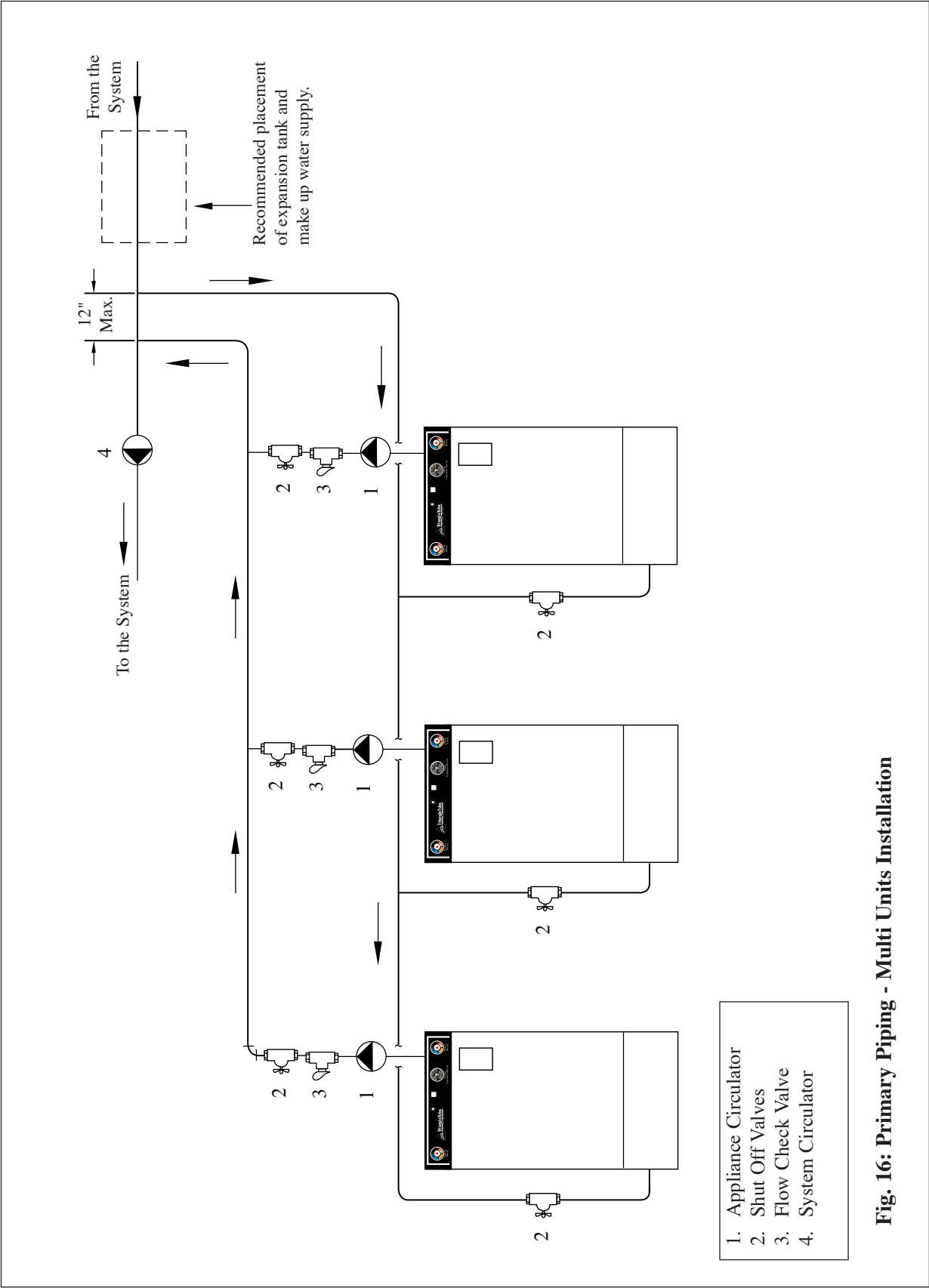

Fig. 16: Primary Piping - Multi Units Installation

SECTION VI - Venting and Combustion Air Installation

General Requirements - Category I

The venting system must be installed in accordance with:

- NFPA 54 National Fuel Gas Code, ANSI Z223.1.
- NFPA 211 Standard for Chimneys, Vent and Solid Fuel Burning Appliances.

For installations in Canada the venting system must be installed in accordance with:

- CGA / B149 Installation Code for Gas Burning Equipment.
- Prior to installing the appliance into an existing chimney or venting system, the vent system should be inspected for condition and obstructions.

WARNING

If the inspection reveals the vent system is not safe for the intended use, it shall be repaired, rebuilt, lined, relined or replaced with a vent or chimney to conform to NFPA 211, latest edition. Failure to conduct such an inspection and/or repair could result in severe personal injury, death or substantial property damage.

- No portion of the venting system shall extend into or pass through any circulating air duct or furnace plenum.
- The gas venting system shall be installed, in accordance with their listings and the manufacturer's instructions.

Masonry and Metal Chimneys

- The NFPA code book severely limits the installation of the PERFORMANCE into a masonry chimney. For applications using either interior or exterior masonry chimney a listed, approved metal chimney lining system should be used.

BEST PRACTICE

For any applications using an exterior chimney it is recommended that an insulated or stainless steel chimney lining system be used.

NOTICE

A chimney with one or more sides exposed to the outside of the structure is considered to be an exterior chimney.

- The chimney shall extend at least 5 feet above the highest connected appliance flue collar.
- The chimney shall extend at least 3 feet above the highest point where it passes through a roof of a building and at least 2 feet higher than any portion of a building within a horizontal distance of 10 feet.

Type B Vent Systems

- The vent system should terminate in accordance with NFPA 54, latest edition, provided the termination is at least 8 feet from a vertical wall or similar obstruction.

BEST PRACTICE

The Type B vent system shall extend in a general vertical direction with offsets not exceeding 45 degrees. A vent system having not more than one 60 degree offset shall be permitted. Any angle greater than 45 degrees is considered horizontal.

BEST PRACTICE

The total horizontal distance of a vent plus the horizontal vent connector shall not be greater than 75% of the vertical height of the vent.

Vent Connectors

- When a vent connector must be located in or pass through an un-conditioned space, attic or crawl space, that portion of the vent connector must be listed as Type B or other approved material having equivalent insulation qualities.
- The minimum clearance to combustibles for single wall vent connectors shall be 6 inches.
- The minimum clearance to combustibles for Type B vent connectors shall be 1 inch or per vent manufacturer's instructions.
- The vent connector shall be installed in a manner to avoid excessive turns or other construction features that create excessive resistance to the flow of the vent gases.
- The vent connector should be installed in a manner without any dips or sags and should slope upward toward the vent or chimney at least 1/4 inch per 1 foot.
- The location of the appliance should be located as close to the vent or chimney to maintain the vent connector length as short as possible.

BEST PRACTICE

The maximum horizontal length allowable should not exceed 75% of the height of the vent or chimney assuming no offsets in the vertical vent.

- The entire length of a vent connector shall be readily accessible for inspection, cleaning and replacement.

- The diameter of the vent connector should not be upsized more than two sizes greater than the flue outlet diameter.

WARNING

The minimum recommended vent connector given in Table 1 is only a general guideline. The vent system must be designed and installed in compliance with all applicable codes. Failure to properly size and install the vent system could result in severe personal injury, death or substantial property damage.

TABLE 1: Vent Connector Diameter

PERFORMANCE Model	Min. Recommended Vent Connector Diameter
PG-25/30	4 inches
PG-35/40/45	5 inches

NOTICE

There are certain applications for the PERFORMANCE in which upsizing the vent connector to 5 inches will not result in sufficient maximum capacity requirements. In these applications the installer, after consultation with Triangle Tube Engineering, may upsize the vent connector to 6 inches provided the vent connector and vent system are Type B.

Common Venting - Category I

The PERFORMANCE may be vented into a common vent system using the guidelines and sizing Tables of the National Fuel Gas Code NFPA 54 ANSI Z223.1 latest edition.

The PERFORMANCE may also be vented into a common multi story vent using the guidelines and sizing Tables of the National Fuel Gas Code NFPA 54 ANSI Z223.1 latest edition.

General Requirements - Category III

- Installation must comply with local requirements and with the National Fuel Gas Code, NFPA 54/ ANSI Z223.1 for U.S. installations and CSA B149.1 or B149.2 for Canadian installations.
- The PERFORMANCE requires a special vent system designed for pressurized venting and is rated as ANSI Z21.13 Category III (pressurized vent system, with flue temperature that avoids excessive condensate within the vent system).
- The PERFORMANCE may be direct vented with outside combustion air or non-direct vented using room air.
- The PERFORMANCE is approved for the following vent manufacturers:
 - Heat-Fab (Saf-T-Vent®)
 - ProTech Systems (FasNSeal®)
 - Flex-L (StaR-34)
 - Z-Flex (Z-Vent III™)

WARNING

DO NOT mix components from different systems. The vent system could fail or improperly seal, causing leakage of flue products into the building.

Category III Vent Termination - Guidelines

Locate the vent termination for direct or non-direct vent applications using the following guidelines:

1. The total equivalent length of the vent should not exceed 100 feet as given in Table 2, page 35.
2. The installer must consider the following when determining the location of the vent termination:
 - Locate the vent termination where flue vapors will not damage surrounding shrubs, plants or air conditioning equip-

ment or be objectionable to the homeowner.

- The flue products will form a noticeable plume as they condense in colder air. Avoid terminating the vent in areas where the plume could obstruct window views.
 - Prevailing winds could cause freezing of flue condensation and a buildup of water / ice on surrounding plants, building surfaces or combustion air inlet.
 - Avoid locations of possible accidental contact of flue vapors with persons or pets.
 - Avoid locations where prevailing winds could affect the performance of the unit or cause recirculation of the flue gases, such as inside corners of buildings or near adjacent buildings or vertical surfaces, window wells, stairwells, alcoves, courtyards, or other recessed areas.
 - Do not terminate the vent above any doors or windows; flue condensate could freeze causing ice formations.
 - Locate or guard the vent termination to prevent possible condensate damage to exterior finishes.
3. The vent termination and vent pipe must not extend more than 12 inches beyond the exterior wall. The vent termination for the horizontal concentric snorkel kit must not extend more than 24" beyond the exterior wall.
 4. Do not connect or terminate any other appliance to the vent system or multiple units into a common vent system.

Category III Termination Clearances

Maintain the following clearances to the vent termination:

- At least 6 feet from adjacent walls

Venting and Combustion Air Installation



- No closer than 5 feet below roof overhangs
- At least 7 feet above any public walkways
- At least 3 feet above any forced air intake (does not include the combustion air inlet) within 10 feet.
- The vent termination must be at least 4 feet from any electric meters, gas meter-regulators, relief valves or other equipment. Never terminate the vent above or below any of these items within 4 feet.
- Vent must terminate at least 12 inches above grade or common snow line.

taining clearances for vertical and horizontal enclosures. In the second option the installer can use the horizontal concentric snorkel kit see Fig. 22B page 36.

If the venting application is a horizontal direct vent:

- Must maintain 12-inch clearances below and horizontally from doors and windows. See dimension A Fig. 17.

If the venting application is a horizontal non-direct vent:

- Must maintain 4 feet of clearance below and horizontally from doors and windows. See dimension A Fig. 17.

NOTICE

In those applications in which the vent termination is below the projected snow line the installer has 2 options. In the first option, the vent system can be routed vertically through an insulated chase or “riser box” and then terminated horizontally. The chase is to be constructed and insulated by the contractor, main-

If the venting application is a vertical direct or non-direct vent application:

- The vent must terminate at least 3 feet above the roof and at least 2 feet higher than any portion of the building within 10 feet.

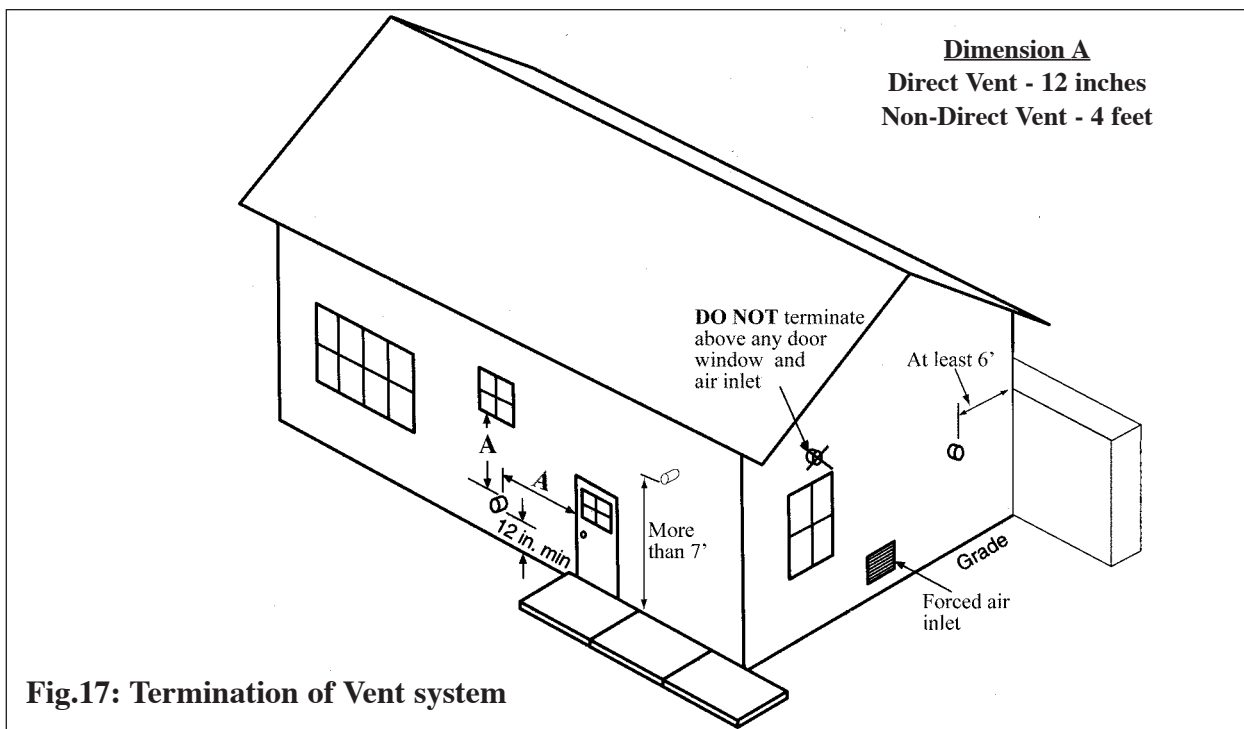

Fig.17: Termination of Vent system

Multiple Vent Terminations

For multiple unit installation venting horizontally, it is recommended to vent as direct vent using the Horizontal Wall Thimble Kit or Horizontal Concentric Kit. The terminations on these installations must maintain the same horizontal centerline and be spaced a minimum 18 inches from center to center.

For multiple unit installation venting vertically, it is recommended to vent as direct vent using Triangle Tube Vertical Concentric Vent Kit. The concentric vent / combustion air terminations must maintain a minimum 18 inch spacing from vent centerline to vent centerline.

Locating the Combustion Air Inlet

When ducting outside combustion air directly to the unit when venting as a Category I or Category III appliance the installer must use the following guidelines:

1. The total equivalent length of the air inlet duct should not exceed 100 feet as given in Table 2, page 35.
2. The installer must consider the following when determining the location of the combustion air inlet:
 - The air inlet must terminate at least 12 inches above grade or projected snow line.
 - The combustion air inlet must be located a minimum 12 inches from the vent termination when installing separate air and vent pipes through a side wall. This does not apply to horizontal concentric-direct venting applications using the Horizontal Wall Thimble kit. See Fig. 23, page 37.
 - The combustion air inlet should not be located above the vent termination.
 - The combustion air inlet must be located in the same pressure zone as the vent termination. This does not apply when venting the appliance as Category I.

Venting Option - Non Direct Vent / Vertical

In this vent application the PERFORMANCE is vented vertically through the roof or an unused chimney using only approved 3 inch stainless steel vent material and using room air for combustion.

The installer should consider the following when choosing this vent option:

- a. The vent system must contain a condensate trap located no higher than 2 feet above the unit. As shown in Fig. 19 page 35.
- b. The vent system must pitch back to the unit 1/4 inch per foot or as specified by the vent manufacturer.
- c. Clearance to combustibles must be maintained per the vent manufacturer's requirements. Refer to the vent manufacturer's installation instructions for additional details.
- d. At a minimum, a 3-inch elbow with screen should be placed on the combustion air inlet of the unit. This will prevent an accidental blockage should anything be placed on top of the unit.

NOTICE

When using an unused chimney as a means of a raceway for the 3 inch vent, the surrounding space cannot be used to draw combustion air.

Venting Option - Direct Vent / Vertical

In this vent application the PERFORMANCE is vented vertically through the roof or an unused chimney using the Triangle Tube concentric Vertical Vent Kit.

The installer should consider the following when choosing this vent option:

- a. The vent system should contain a condensate trap located near the unit as shown in Fig. 20, page 35.
- b. The vent system must pitch back to the unit 1/4 inch per foot as a minimum.
- c. The vent system must maintain the following clearances to combustibles:
 - 0 inches when there are no horizontal offsets and fully enclosed by combustibles on all sides
 - 1 inch when there are horizontal offsets and fully enclosed by combustibles on all sides.
 - 0 inches with or without offsets and unenclosed or with 1 side open and a maximum 3 sides enclosed with combustible materials.
 - 0 inches with or without offsets and enclosed with non combustible materials.

Venting Option - Non-Direct Vent / Horizontal

In this vent application the PERFORMANCE is vented horizontally through a wall using only approved 3-inch stainless steel vent material and using room air for combustion.

The installer should consider the following when choosing this vent option:

- a. The vent system must contain a condensate trap located near the unit as shown in Fig. 21 page 36.
- b. The vent system must be pitched a minimum 1/4 inch per foot or as specified by the vent manufacturer.

BEST PRACTICE

Although the vent system is allowed to pitch away from the unit, it is recommended that the vent system pitches toward the unit with a condensate drain installed as close to the unit as possible. Opting to pitch the vent system away poses potential damage to the building exterior or to the surrounding landscape and/or potential risks of icing if condensate is formed.

- c. Penetration at the wall requires a wall thimble.
- d. Clearance to combustibles must be maintained per the vent manufacturer's requirements. Reference the vent manufacturer's installation instructions for additional details.

NOTICE

Maintain a minimum 2-inch clearance to combustible wall and 1-inch clearance to non-combustible in the absence of the vent manufacturer's recommended clearance when penetrating a sidewall.

- e. At a minimum a 3-inch elbow with screen should be placed on the combustion air inlet of the unit. This will prevent an accidental blockage should anything be placed on top of the unit.

Venting Option - Direct Vent /Horizontal

In this vent application the PERFORMANCE typically is vented horizontally through a wall using only approved 3-inch stainless steel vent material and using outside air for combustion.

The installer should consider the following when choosing this vent option:

- a. The vent system should contain a condensate trap located near the unit as shown in Figs. 22, 22A & 22B, page 36.
- b. The vent system must pitch back to the unit 1/4 inch per foot.

BEST PRACTICE

Although the vent system is allowed to pitch away from the unit, it is recommended that the vent system pitches toward the unit with a condensate drain installed as close to the unit as possible. **Opting to pitch the vent system away poses potential damage to the building exterior or to the surrounding landscape and/or potential risks of icing if condensate is formed.**

- c. Penetration at the wall requires a thimble.
- d. Clearance to combustibles must be maintained per the vent manufacturer's requirements. Refer to the vent manufacturer's installation instructions for additional details.

NOTICE

Maintain a minimum 2-inch clearance to combustible wall and 1-inch clearance to non-combustible in the absence of the vent manufacturer's recommended clearance when penetrating a sidewall.

- e. For a zero clearance concentric termination of the vent and combustion air refer to the Horizontal Concentric, Horizontal Single Wall Vent or Horizontal Wall Thimble Kits.

There are two methods available for Direct Venting - Horizontal:

Separate: The vent and the combustion air inlet are run together and exit the structure separately with different terminations. See Fig. 23, page 37.

NOTICE

The combustion air inlet and the vent termination must reside in the same pressure zone area of the building for proper operation of the appliance.

Combination: The vent and combustion air terminate at a single concentric point using the Horizontal Concentric, Horizontal Single Wall Vent or Horizontal Wall Thimble Kit. See Figs.: 22,22A and 22B, page 36.

Horizontal Wall Thimble Kit

- Requires a 5 1/2 inch x 5 1/2 inch penetration through any type of wall.
- Allows zero clearance at the wall penetration.
- Maximum wall thickness is 11 inches.
- The use of a termination elbow for the venting system is not recommended when using the Horizontal Wall Thimble Kit.

BEST PRACTICES

To prevent potential nuisance lock-outs or flue gas recirculation it is recommended to terminate the vent with a horizontal termination tee or side discharge vent hood.

Excessive Horizontal Vent Runs

If maintaining the 1/4 inch per foot pitch requirement creates clearance problems with structural obstacles, i.e. low ceilings, the installer may opt to installing the vent in a manner that pitches up to a high point from the unit and then pitches away from the high point to the vent termination.

A condensate tee should be installed as close as possible to the unit when venting in this manner.

The vent run from the high point to the vent termination should be as minimal in length as possible to reduce the amount of potential condensate at the vent termination.

The vent system must maintain the 1/4 inch per foot pitch to the high point and from the high point to the vent termination.

Vent Appliance Adapters

- The PERFORMANCE requires the use of an appliance adapter as approved by the one of vent manufacturers listed on page 29.

WARNING

Failure to use an approved vent appliance adapter may create improper vent connection and potential flue gas leakage. Do not mix the manufacturer appliance adapter with other manufacturers' vent components, the vent system could fail or improperly seal, causing leakage of flue products into the building.

Vent Condensate Drain

A vent condensate drain and drain tube should be installed near the appliance to prevent any potential condensate from entering the flue ways on the unit. See Figs. 19 through 22B pages 35 & 36.

WARNING

Failure to provide a vent condensate drain close to the appliance could allow acidic flue gas condensate to enter into the appliance flue ways causing premature failure of the appliance.

Condensate Drain Tube

To prevent flue gases from entering into the building it is important the drain tube is fashioned into a “pigtail” trap as shown in Figs. 19 through 22B pages 35 & 36.

The drain tube must be filled with water to prevent flue gases from emitting into the building prior to operating the appliance.

NOTICE

Periodically inspect the water level in the condensate drain tube. If low, add water as needed to maintain trap level.

If water in drain tube evaporates rapidly due to ambient conditions, propylene glycol may be added or substituted to reduce evaporation.

Pipe the condensate drain tube to a suitable place of drainage or to a condensate pump or sump. Consult local authorities regarding disposal of flue gas condensate into public waste water system.

Determining Piping Lengths

Once the venting method and location for the vent termination has been determined the installer must select the vent components required for the system.

The maximum combined equivalent lengths for venting and combustion air inlet are as follows:

- Delta PERFORMANCE - 200 feet (100 feet each)

NOTICE

The maximum equivalent length is the total length of the venting and the combustion air inlet combined. This includes termination fittings.

NOTICE

For Delta PERFORMANCE applications that may exceed the 100 feet maximum allowable equivalent length for the venting system, contact Triangle Tube Engineering Department for additional information on how the appliance can be adjusted to the application.

- For each elbow included in the system, the maximum allowable linear length must be reduced as follows:

- Each 90° elbow within the system is the equivalent of 10 linear feet.
- Each 45° elbow within the system is the equivalent of 5 linear feet.

It is recommended that the installer uses the same number of elbows and length of piping on the venting system and the combustion air inlet.

Table 2- Allowable Equivalent Length (Combined Vent and Combustion Air)

Maximum Allowable for Linear Length Combined	Total Elbows within the Venting / Combustion Air System					
	2	3	4	5	6	7
PERFORMANCE	180	170	160	150	140	130

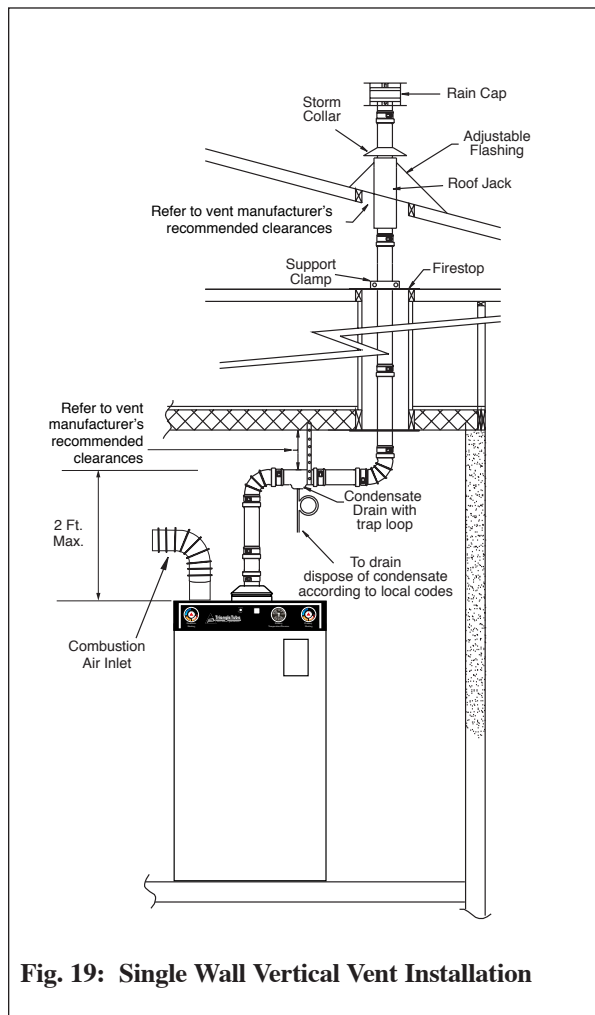

Fig. 19: Single Wall Vertical Vent Installation

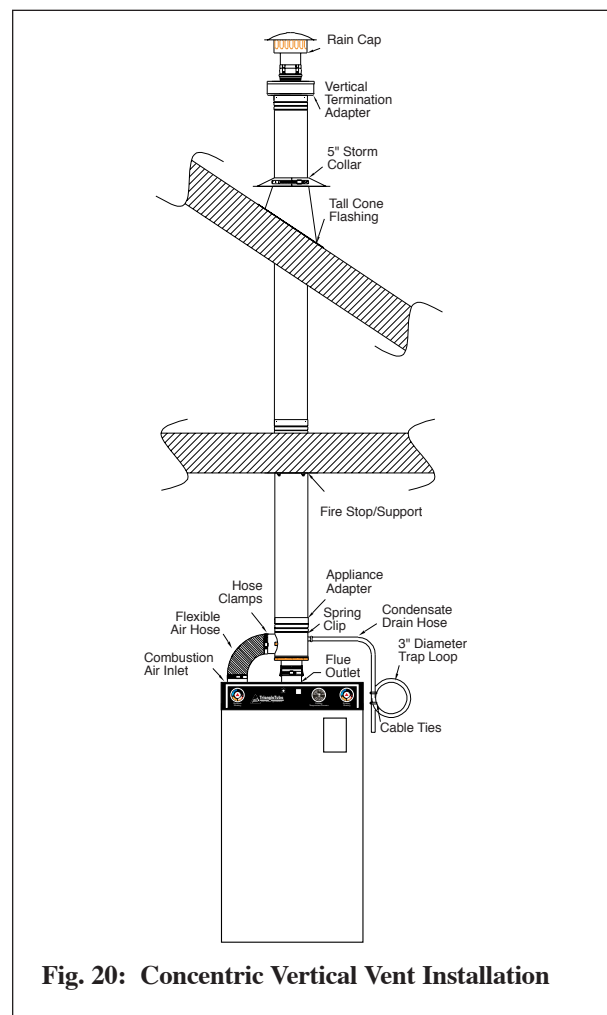

Fig. 20: Concentric Vertical Vent Installation

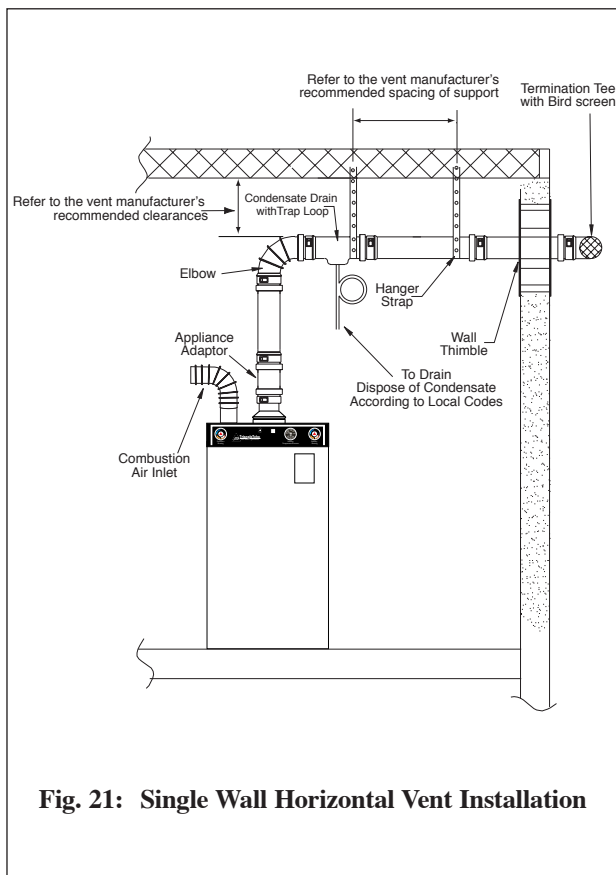

Fig. 21: Single Wall Horizontal Vent Installation

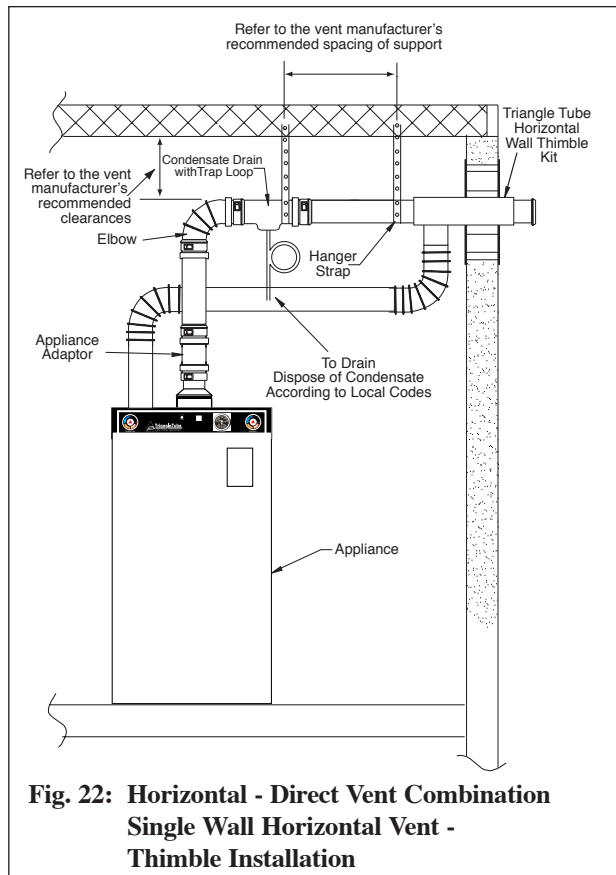

Fig. 22: Horizontal - Direct Vent Combination Single Wall Horizontal Vent - Thimble Installation

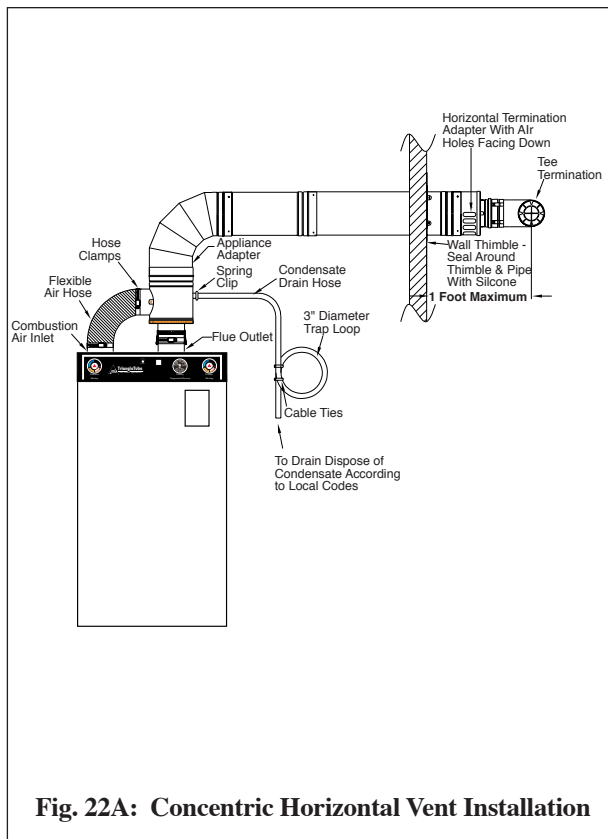

Fig. 22A: Concentric Horizontal Vent Installation

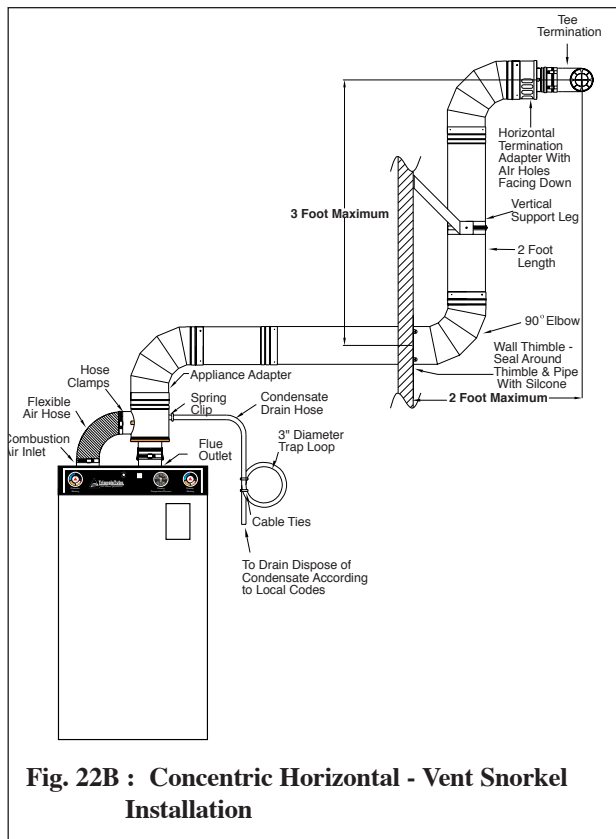
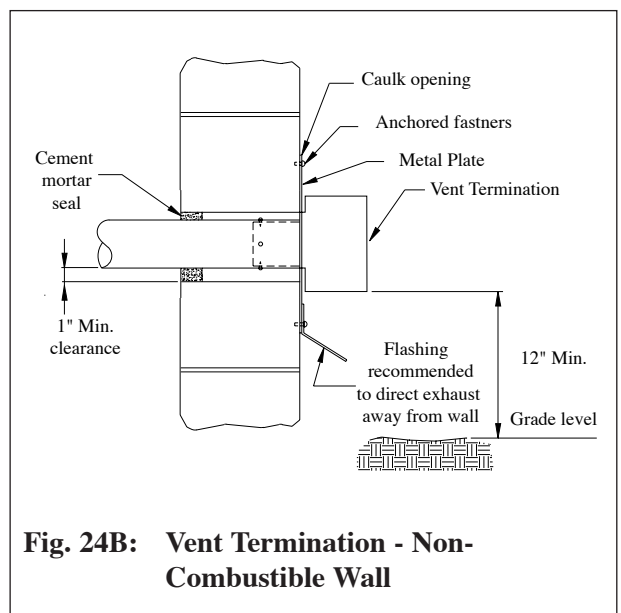
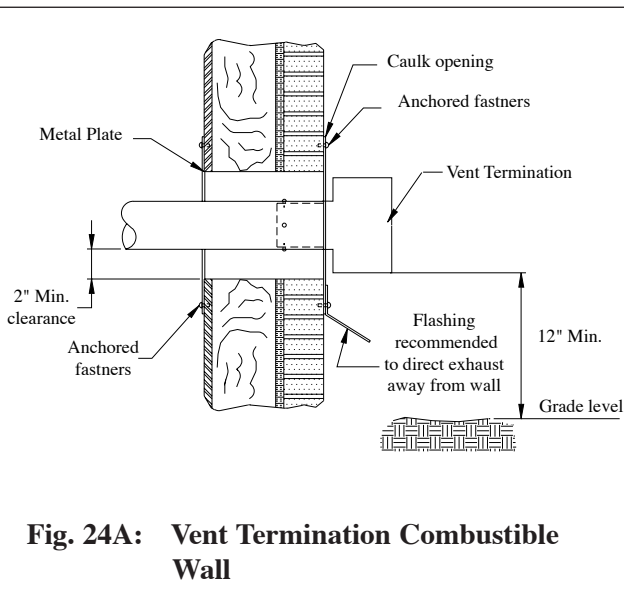
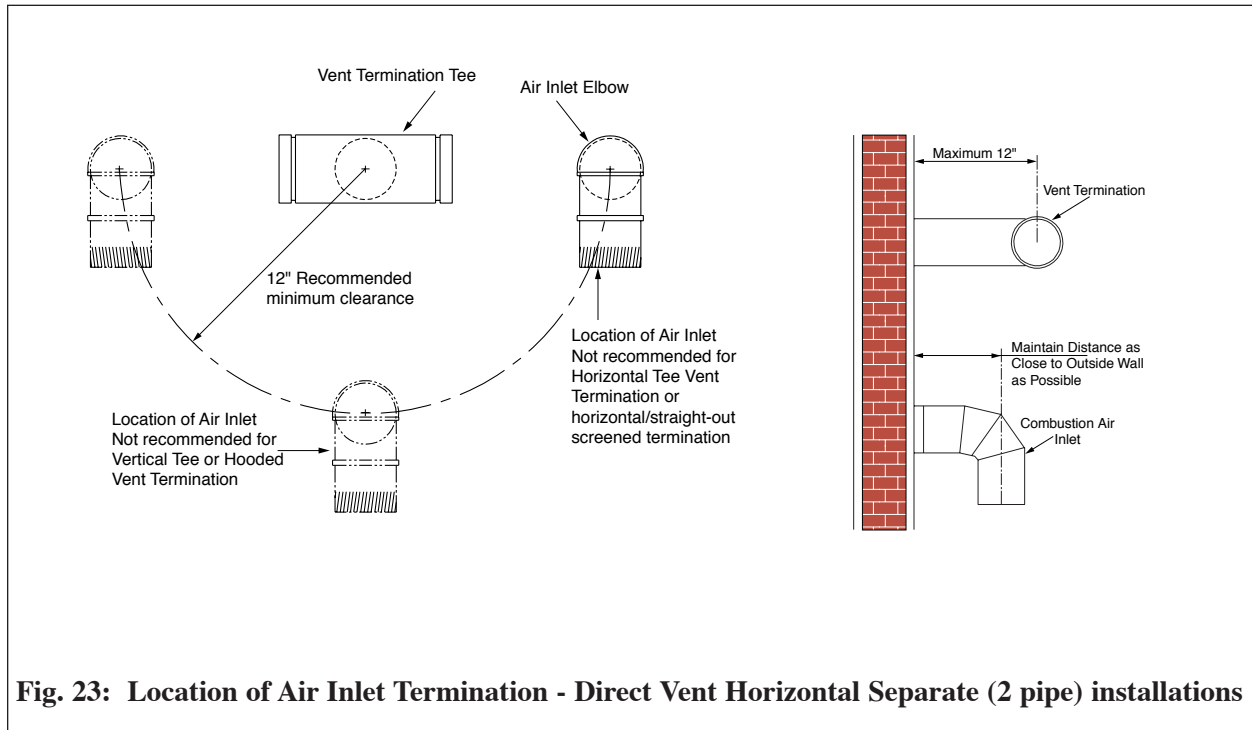

Fig. 22B : Concentric Horizontal - Vent Snorkel Installation



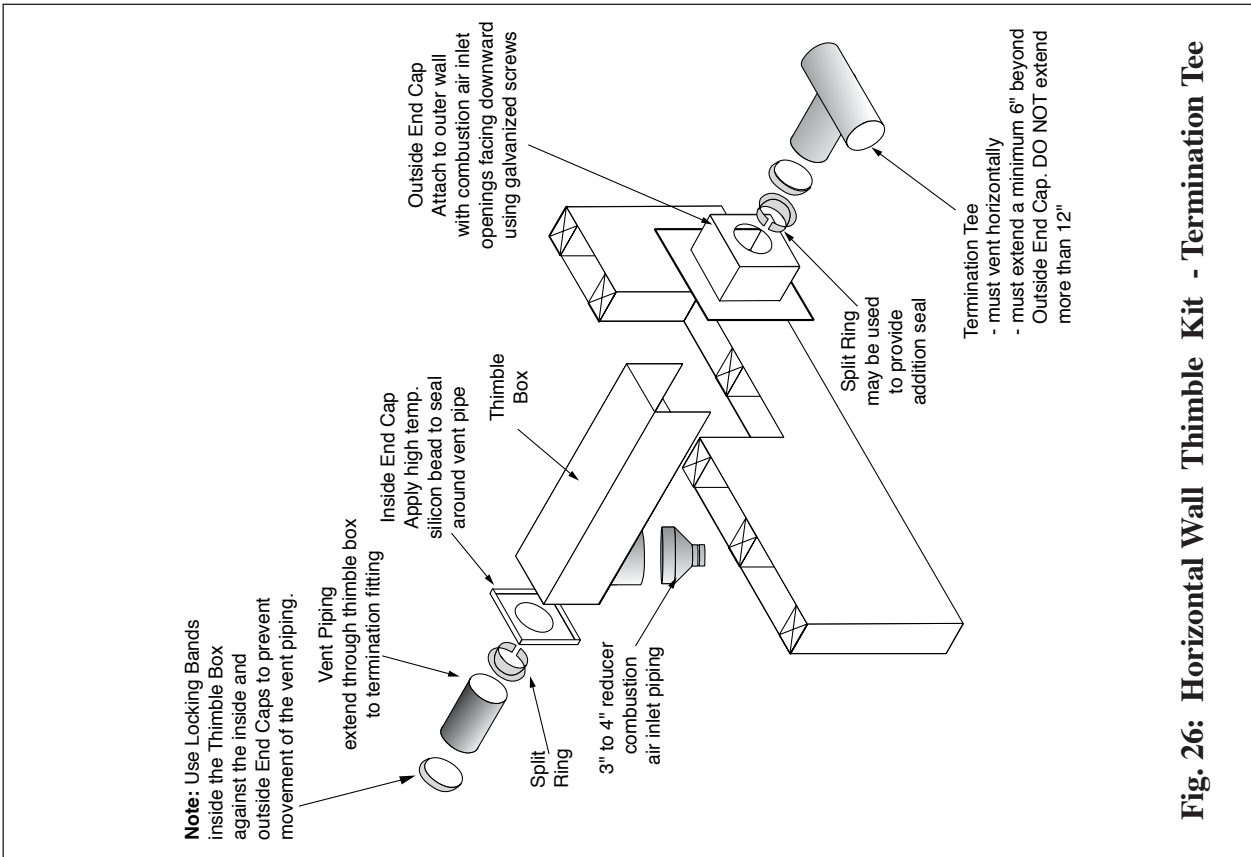

Fig. 26: Horizontal Wall Thimble Kit - Termination Tee

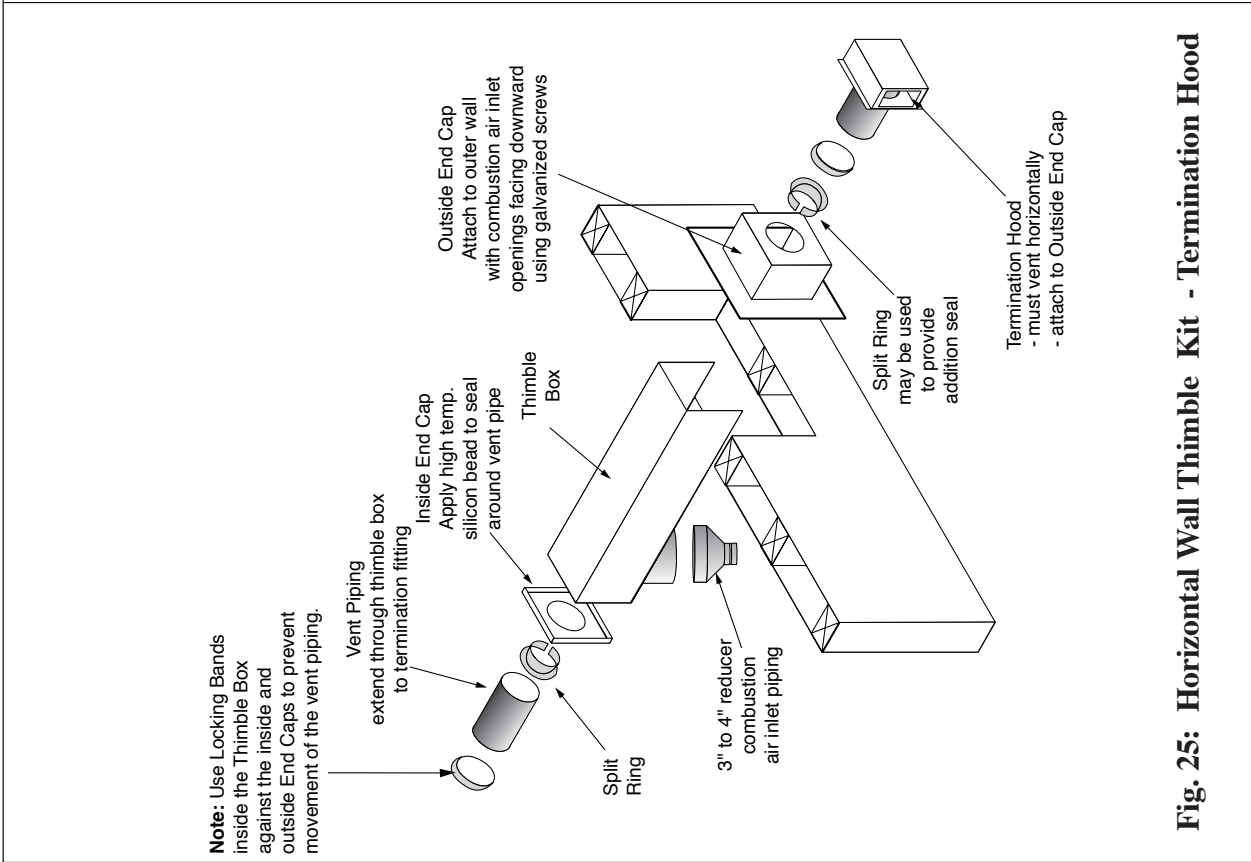

Fig. 25: Horizontal Wall Thimble Kit - Termination Hood

SECTION VII - Gas Piping

Gas Supply Piping Connection

NOTICE

The gas supply piping must be installed in accordance to all applicable local, state and national codes and utility requirements.

1. Remove the burner jacket hood. Refer to Figure 27 to pipe gas supply to the burner.
 - a. Install a pipe union at the factory supplied gas nipple, for ease of service.
 - b. Install a manual shutoff valve in the gas supply piping as shown in Figure 27. For installations in Canada, the installer must tag and identify the main shutoff valve.
 - c. Install a drip leg on the gas supply line prior to connecting to the PERFORMANCE gas train as shown in Figure 27.
2. Support the gas piping using hangers. Do not support the piping by the unit or its components.
3. Purge all air from the gas supply piping.
4. Before placing the PERFORMANCE into operation, check and test all connections for leaks.

Close the manual shutoff valve during any pressure test with less than 13”w.c..

Disconnect the PERFORMANCE and its gas valve from the gas supply piping during any pressure test greater than 13”w.c..

WARNING

Do not check for gas leaks with an open flame. Use a gas detection device or bubble test. Failure to check for gas leaks can cause severe personal injury, death or substantial property damage.

5. Use pipe dope compatible with natural and propane gases. Apply sparingly only to the male threads of pipe joints so that pipe dope does not block gas flow.

WARNING

Failure to apply pipe dope as detailed above can result in severe personal injury, death or substantial property damage.

WARNING

Use a two-wrench method of tightening gas piping near the unit and its gas valve. Use one wrench to prevent the gas valve line connection from turning and the second to tighten adjacent piping. Failure to support the gas valve connection piping could damage the valve and the gas line components.

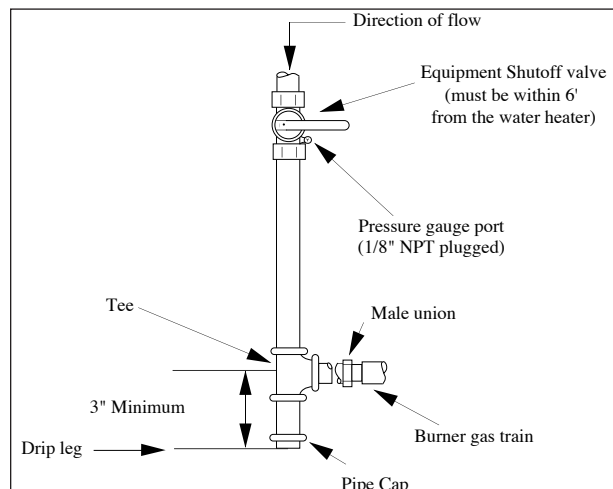

Fig. 27: Recommended Gas Supply Piping

NATURAL GAS

Pipe Sizing - Natural Gas

1. Refer to Table 3 for pipe length and diameter requirements. Based on rated PERFORMANCE input (divide by 1,000 to obtain cubic feet per hour).
 - Table 3 is based on Natural Gas with a specific gravity of 0.60 and a pressure drop through the gas piping of 0.30”w.c..
 - For additional gas piping sizing information, refer to ANSI Z223.1. For Canadian installations refer to B149.1 or B149.2.

2. Install 100% lockup gas pressure regulator in the gas supply line if inlet pressure can exceed 13”w.c at any time. Adjust the lock-up pressure regulator for 13”w.c maximum.

WARNING

DO NOT adjust or attempt to measure gas valve outlet pressure. The gas valve is factory-set for the correct outlet pressure. This setting is suitable for natural gas and propane and requires no field adjustment. Attempts by the installer to adjust or measure the gas valve outlet pressure could result in damage to the valve, causing potential severe personal injury, death or substantial property damage.

Natural Gas Supply Pressure Requirements

1. Pressure required at the gas valve inlet supply pressure port:
 - Maximum 13”w.c. at flow or no flow conditions to the burner.
 - Minimum 5”w.c. during flow conditions to the burner. Must be verified during start up and with all gas appliances operating.

Table 3: Gas piping sizing - Natural Gas

Length of Pipe in Feet	Capacity of Pipe in Cubic Feet of Gas Per Hour (based on 0.60 specific gravity, 0.30" w.c. pressure drop)				
	SCH 40	1/2"	3/4"	1"	1-1/4"
10	132	278	520	1050	1600
20	92	190	350	730	1100
30	73	152	285	590	860
40	63	130	245	500	760
50	56	115	215	440	670
75	45	93	175	360	545
100	38	79	150	305	460
150	31	64	120	250	380

PROPANE GAS

WARNING

Pipe Sizing - Propane Gas

1. Contact the local propane gas supplier for recommended sizing of piping, tanks and 100% lockup gas regulator.

DO NOT adjust or attempt to measure gas valve outlet pressure. The gas valve is factory-set for the correct outlet pressure. This setting is suitable for natural gas and propane and requires no field adjustment. Attempts by the installer to adjust or measure the gas valve outlet pressure could result in damage to the valve, causing potential severe personal injury, death or substantial property damage.

Propane Gas Supply Pressure Requirements

1. Adjust the propane supply regulator provided by the gas supplier for 13" w.c. maximum pressure
2. Pressure required at the gas valve inlet supply pressure port:
 - Maximum 13" w.c. at flow or no flow conditions to the burner
 - Minimum 5" w.c. during flow conditions to the burner. Must be verified during start up and with all gas appliances operating.

WARNING

Prior to start up, ensure the unit is set to fire propane. Check the rating label for the type of fuel. Check the gas valve and air inlet for propane conversion labels. If there is a conflict or doubt on the burner set up, remove the gas valve and check for the propane orifice. Failure to ensure proper burner setup could result in severe personal injury, death or substantial property damage.

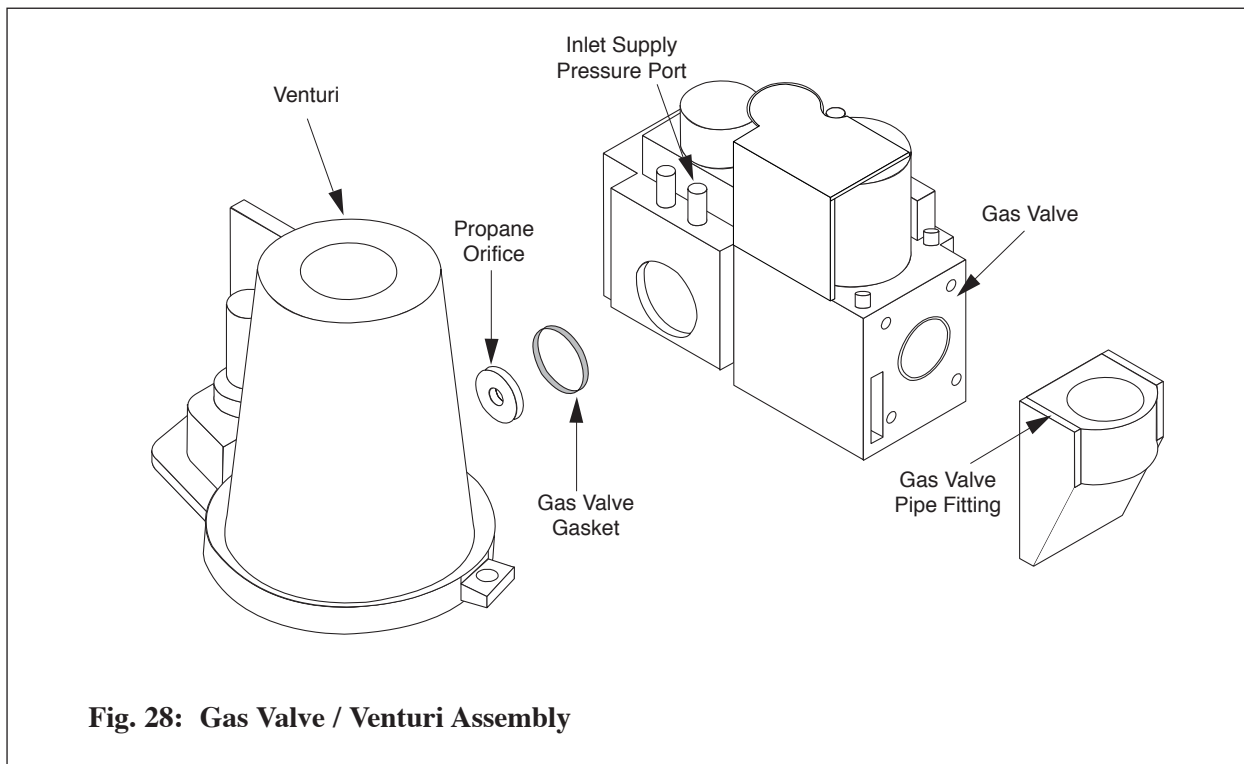

Fig. 28: Gas Valve / Venturi Assembly

SECTION VIII - Internal Wiring

General Requirements

WARNING

ELECTRICAL SHOCK HAZARD. For your safety, disconnect electrical power supply to the unit before servicing or making any electrical connections to avoid possible electric shock hazard. Failure to do so can cause severe personal injury or death.

- Wiring must be N.E.C Class 1.
- If original wiring installed in the unit must be replaced, use only type T, 90°C wire or equivalent.
- The PERFORMANCE must be electrically grounded as required by National Electrical Code ANSI/NFPA 70 - latest edition.

NOTICE

All electrical contacts shown in Figures 30 & 31 pages 43 & 44 do not have electrical power applied. Shown as “off-shelf” condition.

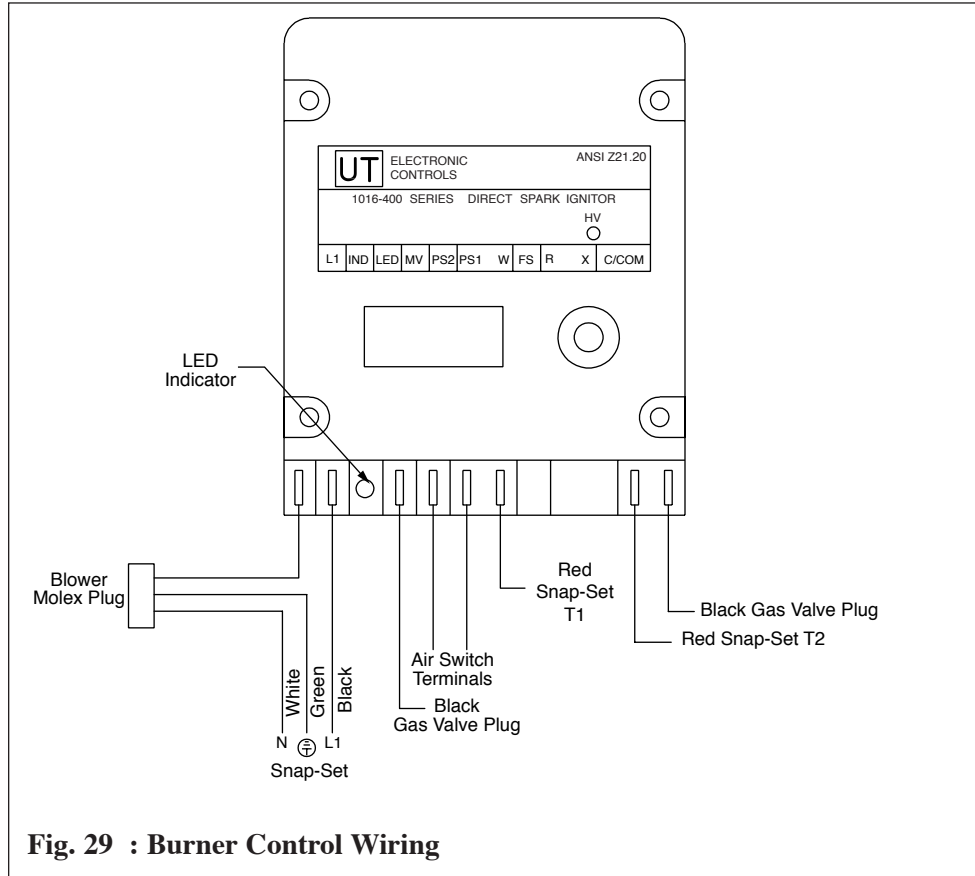

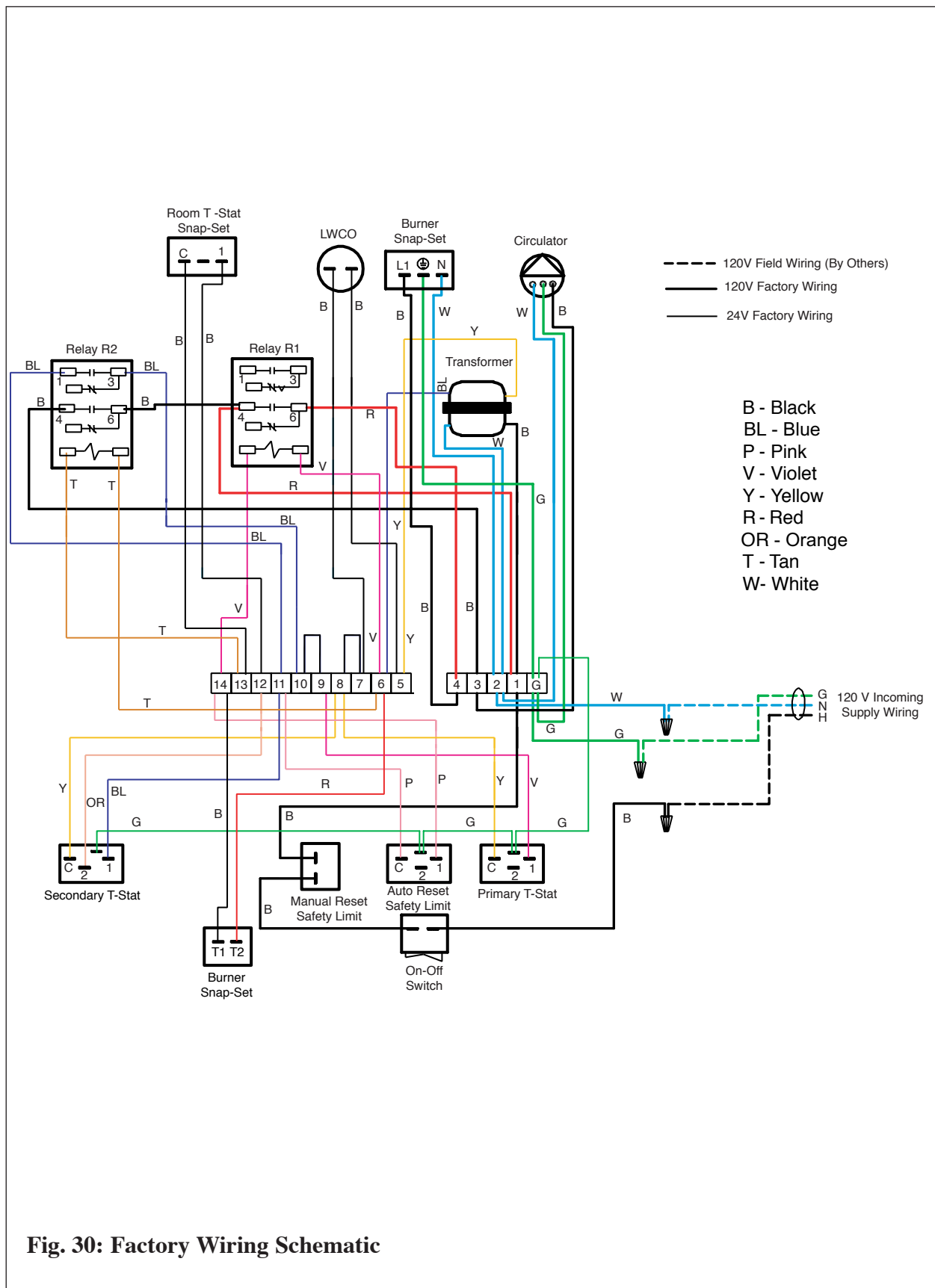

Fig. 30: Factory Wiring Schematic

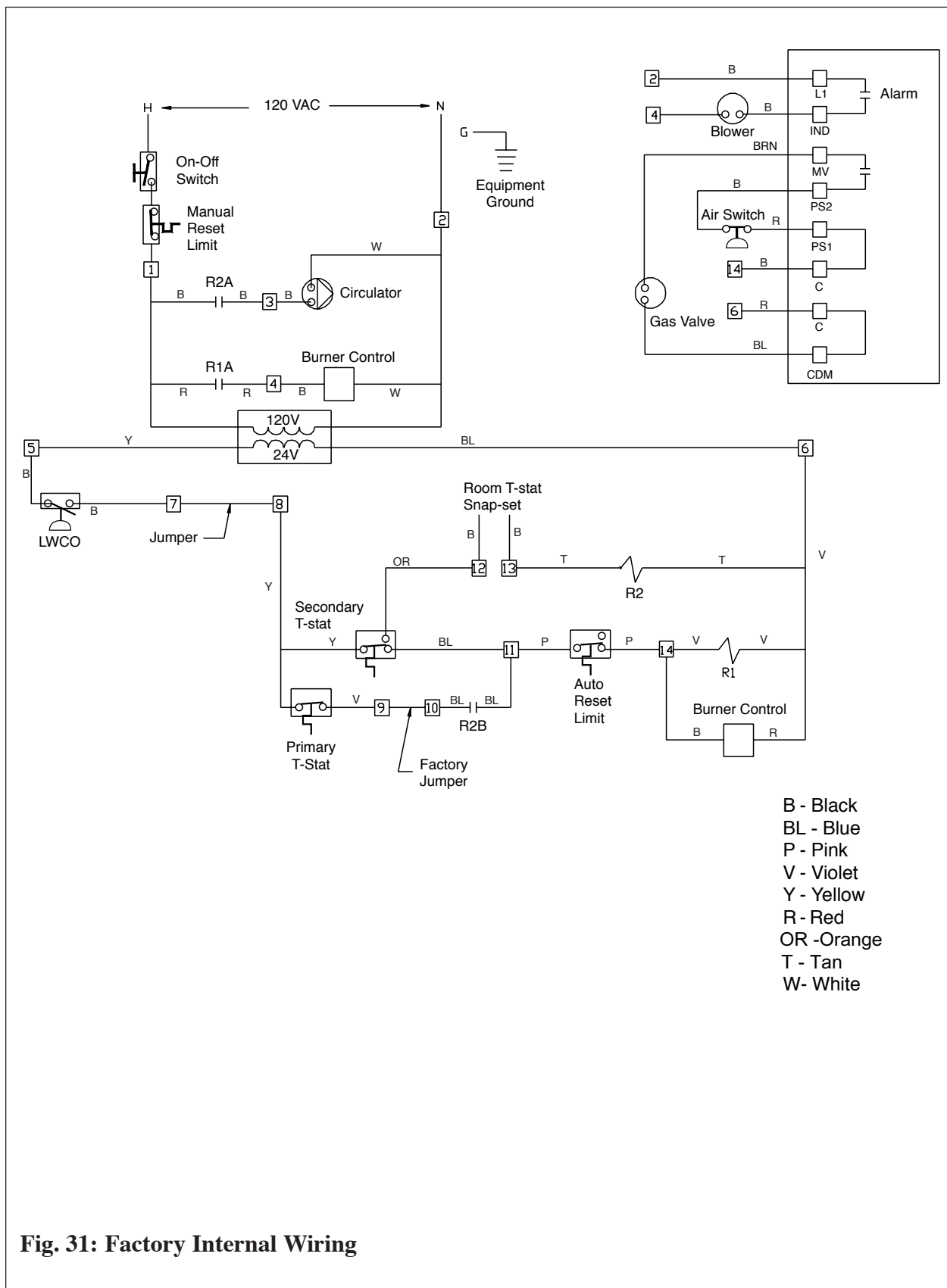

Fig. 31: Factory Internal Wiring

SECTION IX - External Wiring

Installation Compliance

All field wiring made during installation must comply with:

- National Electrical Code NFPA 70 and any other national, state, provincial or local codes or requirements.
- In Canada, CSA C22.1 Canadian Electrical Code Part 1, and any other local codes.

Line Voltage Connections

1. Connect 120 VAC power wire to the line voltage leads located behind the front control panel.
2. Route the incoming 120 VAC power wire through the right side jacket panel.
3. Use the wire nuts provided to ensure a tight and secure connection.
4. The unit is provided with a service switch. Check local code requirements for compliance.

NOTICE

If local electrical codes or conditions require an additional service switch, the installer must provide and install a fused disconnect or 15 amp (minimum) service switch.

Thermostat Wiring

1. Connect room thermostat or the end switch (isolated contact only) of a relay control panel to the Room Thermostat Snap-set located on the rear jacket panel.
2. Remove the snap-set cover and connect the thermostat wiring to terminals C and 1 per Figure 32.
3. For proper operation, install the room thermostat on an inside wall away from influences of heat and cold, i.e. water pipes,

areas of draft, lighting fixtures and fireplaces.

4. Set the thermostat anticipator (if applicable) as follows:
 - Set for 0.2 amps when wired directly to the Room Thermostat Snap-set.
 - Set to match the total electrical power requirements of the connected devices when wired to zone relays or other devices. Refer to the relay manufacturers' specifications and the thermostat instructions for additional information on the anticipator setting.

Outdoor Temperature Limit

1. The PERFORMANCE may operate with a variable primary operating temperature using an outdoor reset control provided by the installer.
2. Remove the factory jumper across terminals 9 and 10 see Figs. 30 & 31, on pages 43 & 44. Connect the outdoor limit control to those terminals.
3. Set the operating limits of the outdoor limit control as follows:
 - Maximum operating temperature of 180°F.
 - Minimum operating temperature of 150°F.
4. Set the primary thermostat to the highest possible setting.

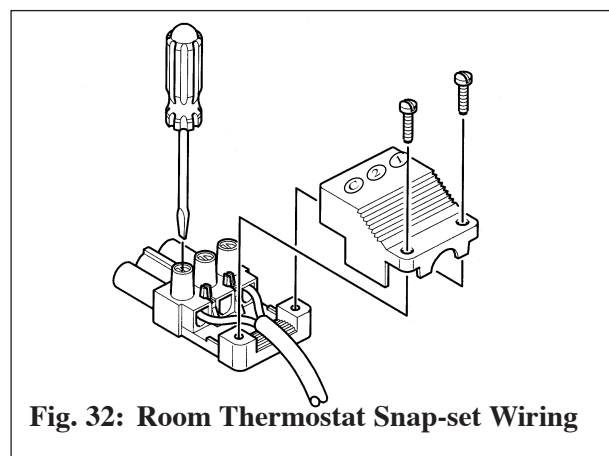

Fig. 32: Room Thermostat Snap-set Wiring

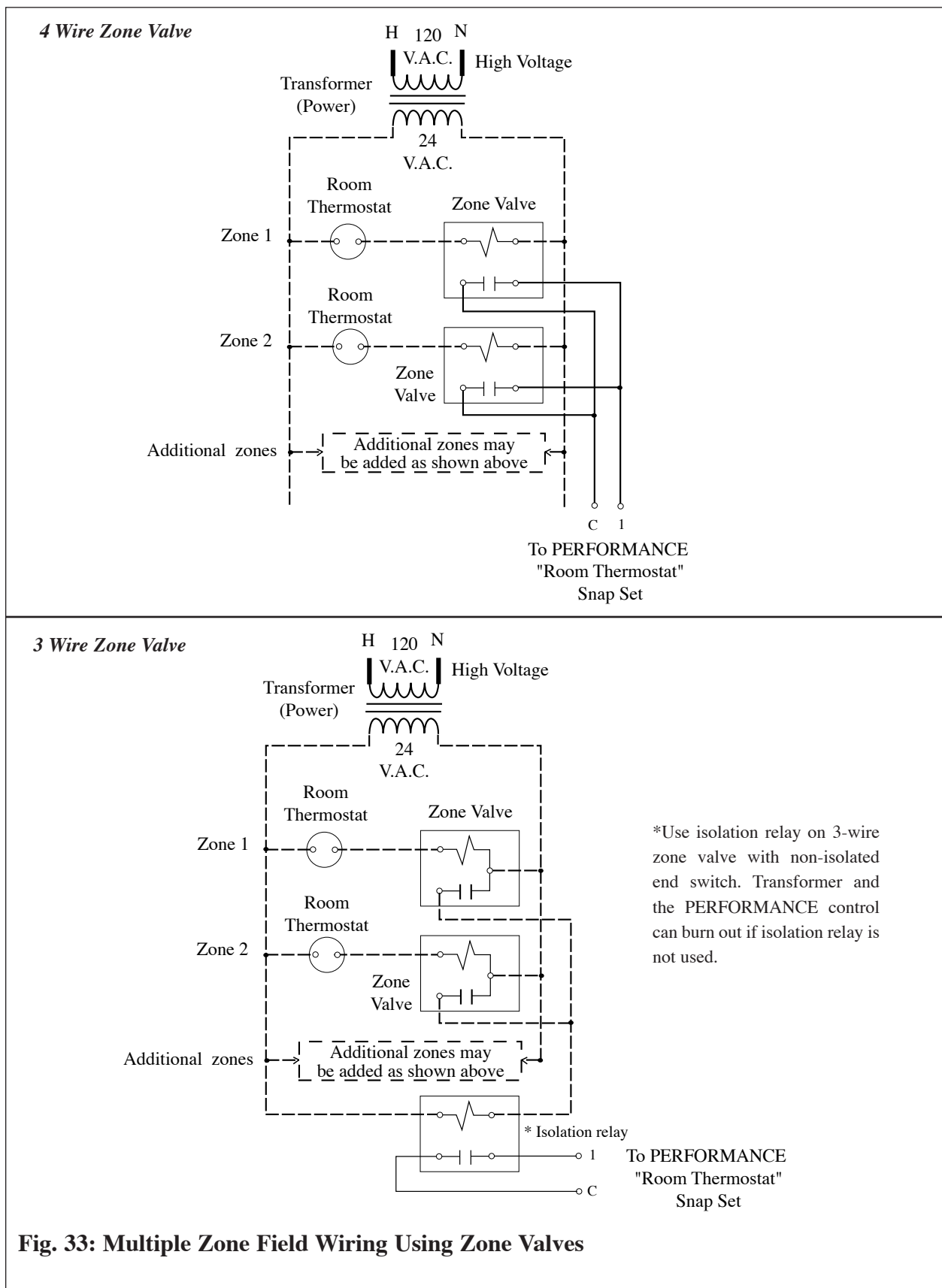

Fig. 33: Multiple Zone Field Wiring Using Zone Valves

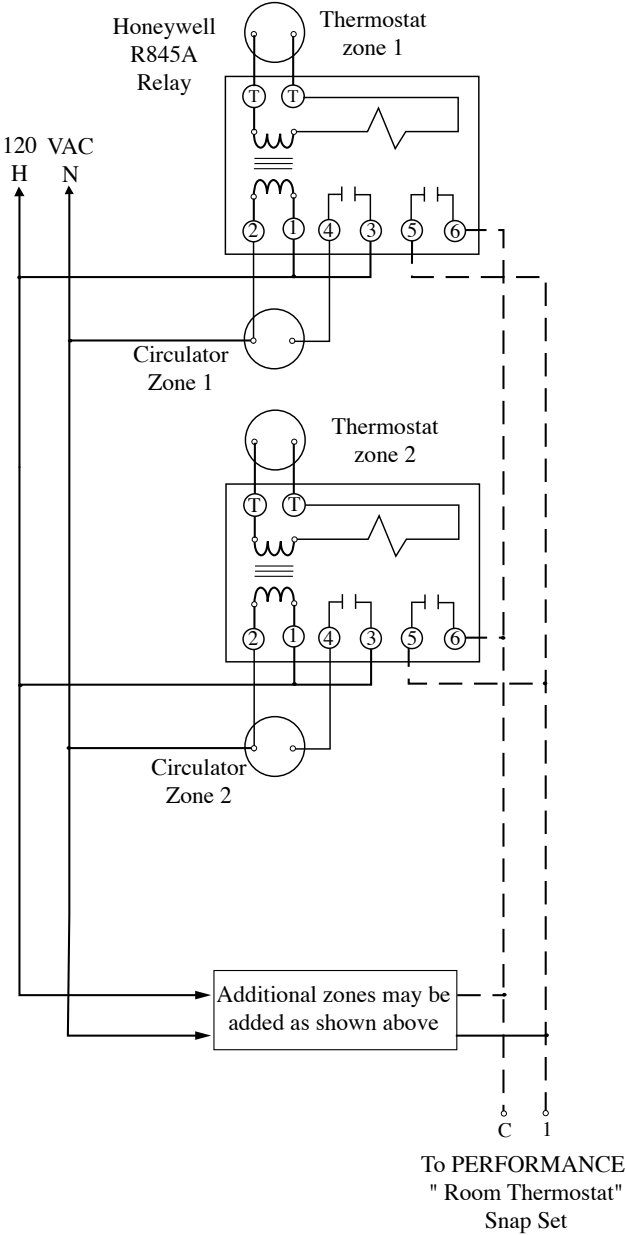

Fig. 34: Field wiring with zone circulators.

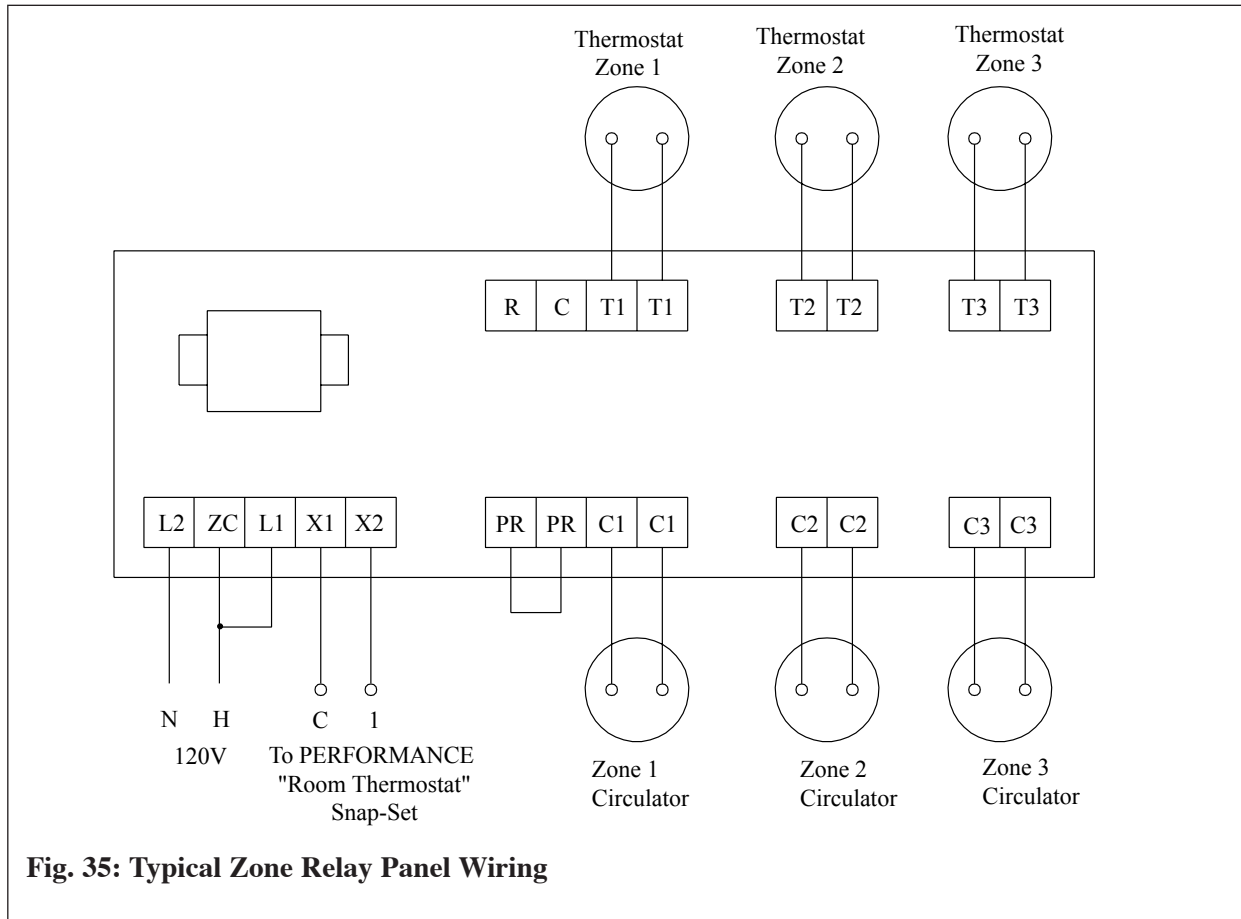

Fig. 35: Typical Zone Relay Panel Wiring

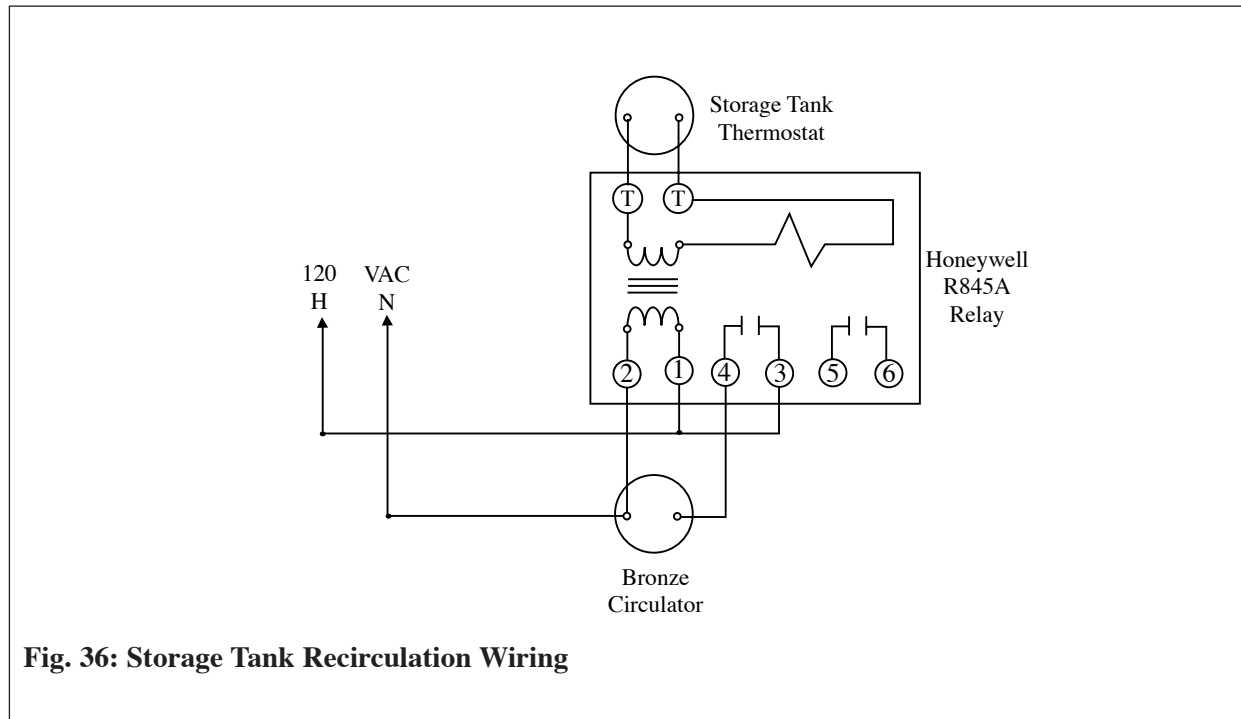

Fig. 36: Storage Tank Recirculation Wiring

SECTION X - Start Up Preparation

Check System and Domestic Water Chemistry

WARNING

Do not use petroleum-base cleaning or sealing compounds in the primary system. Damage to seals and gaskets in the system components could occur, resulting in substantial property damage.

NOTICE

System water including additives must be practically non-toxic, having a toxicity rating or Class of 1, as listed in Clinical Toxicology of Commercial Products.

Water pH Level 6.0 to 8.0

Maintain the primary system water pH between 6.0 and 8.0. Check using litmus paper or contact a water treatment company for a chemical analysis.

If the pH does not meet this requirement, do not operate the PERFORMANCE or leave the unit filled until the condition is corrected.

Water Hardness Less Than 7 Grains

For areas with unusually hard water (hardness above 7 grains) consult a water treatment company.

Chloride Concentration Less Than 80 mg/L

For those installations that use a water softener or conditioner, consult the water treatment company.

NOTICE

Any water conditioning system must be installed and maintained in accordance with the water conditioner's manufacturer's specifications and within the operating guidelines of the PERFORMANCE.

Chlorinated Water

Do not use the PERFORMANCE inner or outer tank to heat a swimming pool or spa directly.

Maintain the chlorine level of the water in the inner and outer tanks at levels considered safe for drinking.

Flush Primary and Domestic System to Remove Sediment

The installer must flush both the primary and domestic system to remove any sediment to allow proper operation of the PERFORMANCE.

Flush the systems until the water runs clean and is free of sediment.

For primary zoned systems, each zone should be flushed through a purge valve. Purge valves and isolation valves should be installed on each zone to allow for proper flushing of the system.

Check and Test Antifreeze

For primary systems containing antifreeze solutions, follow the antifreeze manufacturer's instructions in verifying the inhibitor level and to ensure the fluid characteristics are within specification requirements.

Due to the degradation of inhibitors over time, antifreeze fluids must be periodically replaced. Refer to the manufacturer of the antifreeze for additional instructions.

NOTICE

System water, including additives must be practically non-toxic, having a toxicity rating or Class of 1, as listed in Clinical Toxicology of Commercial Products.

Use of Antifreeze in the Primary System

WARNING

NEVER use automotive or ethylene glycol antifreeze or undiluted antifreeze in the primary system as freeze protection. This can cause severe personal injury, death or substantial property damage if ignored.

Determine the antifreeze fluid quantity using the system water content volume and following the antifreeze manufacturer instructions.

The primary outer tank volume of the PERFORMANCE is 20 gallons. Remember to include the volume of the expansion tank.

Check with local codes requirements for the installation of back flow preventers or actual disconnect from the make up water supply line.

Ensure the concentration of antifreeze to water does not exceed a 50/50 ratio.

NOTICE

System water including additives must be practically non-toxic, having a toxicity rating or Class of 1, as listed in Clinical Toxicology of Commercial Products.

Filling the Inner (Domestic) Tank and System

WARNING

Proceed with filling instructions for the inner and outer tanks only after ensuring the water meets the requirements listed in this installation manual. Failure to comply could result in damage and improper operation of the unit.

CAUTION

Never operate the PERFORMANCE unless both the inner and outer tanks are completely filled.

CAUTION

Always fill the inner tank prior to filling and pressurizing the outer tank. Failure to properly fill the inner tank could result in damage to the inner tank.

1. Ensure the domestic drain valve is closed.
2. Open the isolation valves on the domestic cold supply piping to the PERFORMANCE and on the domestic hot outlet piping to the building (if provided).
3. Vent any air from the domestic piping system by opening faucets near the unit. Continue filling the domestic system until there is a constant flow of water from the faucets.
4. Close the hot water faucets.

Filling the Outer (Primary) Tank and System

1. Close the primary drain valve located on the rear of the unit and any manual or automatic air vent in the system.
2. Open all system isolation valves.

- Fill the outer tank to correct system pressure. Correct pressure will vary with each application.

NOTICE

Typical residential system fill pressure is 12 psi. System pressure will increase when system temperature increases. Operating pressure of the system should never exceed 25 psi.

- Allow air to escape from the outer tank by opening the automatic air vent provided with the PERFORMANCE.
- Purge air in each zone of the primary system through the purge valve. Open air vents to allow air to be purged in the zones.
- Once the system is completely filled and purged of all air, check the system pressure and check for leaks.

Check Low Water Cut-Off Device

- The PERFORMANCE is provided with a factory installed Low Water Cut-Off device that measures system pressure of more than 10 psi.
- Remove the front jacket panel and check for continuity across the low water cut-off device wire terminals. The contacts should be closed when system pressure is greater than 10 psi.

Check For Gas Leaks

WARNING

Prior to start-up and during initial operation, smell near the floor and around the unit for gas odorant or any unusual odor. Do not proceed with the start-up if there is any indication of a gas leak. Any leaks found must be repaired immediately.

WARNING

DO NOT adjust or attempt to measure gas valve outlet pressure. The gas valve is factory-set for the correct outlet pressure. This setting is suitable for natural gas and propane and requires no field adjustment. Attempts by the installer to adjust or measure the gas valve outlet pressure could result in damage to the valve, causing potential severe personal injury, death or substantial property damage.

WARNING

Propane installations only - The propane supplier mixes an odorant with the propane to make its presence detectable. In some cases the odorant can fade and the gas may no longer have an odor.

Prior to start-up of the unit and periodically after start-up, have the propane supplier check and verify the odorant level.

Table 4 : Pressure Switch Setting

PG Model	Natural Gas (inch w.c.)	Propane (inch w.c.)	High Altitude (Above 5,000 feet)	
			Natural Gas (inch w.c.)	Propane (inch w.c.)
PG-25	1.84 " w.c.	3.35" w.c.	n/a	n/a
PG-30	1.84 " w.c.	3.35" w.c.	2.7" w.c.	3.35" w.c.
PG-35	1.84 " w.c.	3.35" w.c.	3.35" w.c.	3.35" w.c.
PG-40	2.7 " w.c.	3.35" w.c.	2.7 " w.c.	3.35" w.c.
PG-45	2.7 " w.c.	3.35" w.c.	2.7 " w.c.	3.35" w.c.

Pressure Switch Identification:

- YELLOW Label: 1.84" w.c.
- RED Label: 2.7" w.c.
- BLUE Label: 3.35 w.c
- n/a -Models not available.

Verify Correct Pressure Switch

1. Remove the burner hood and verify the burner pressure switch setting.
2. Check and compare the color of the outline on the pressure switch label to Table 4 page 51.

NOTICE

The PERFORMANCE is equipped with an air pressure switch, which provides a safe means of shutting down the unit due to a blockage of the combustion air inlet. The switch is “normally closed” and measures the change in the negative pressure (vacuum) created by the burner blower.

- Close each thermostat, zone valve and relay in the external circuit one zone at a time and check the voltage reading across the plug.
- There should **NEVER** be voltage measured at the plug.
- If voltage is measured at the plug under any condition, check and correct the external wiring.

NOTICE

In systems using 3-wire zone valves backfeed of voltage to the unit is a common problem. Use an isolation relay to prevent voltage from the external circuit entering the Room Thermostat Snap-set. See Fig. 33, page 46.

Verify Correct Air Shutter Setting

- Check and verify the air shutter setting as listed in Table 5.
- The air shutter is located inside the combustion air inlet adapter located in the top /left jacket panel area. See Fig. 37.

Check Thermostat Circuit

- Unplug the Room Thermostat Snap-set located on the rear of the unit.
- Connect a voltmeter across the end terminals of the male half of the Room Thermostat Snap-set.

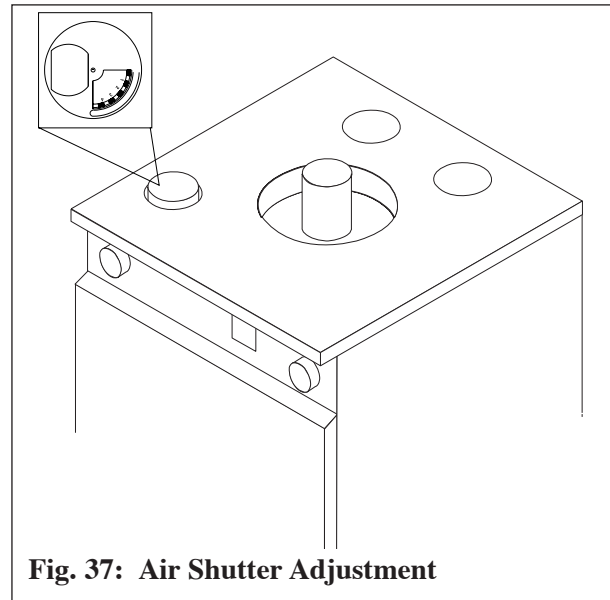

Fig. 37: Air Shutter Adjustment

Table 5 : Air Shutter Settings

Model	Natural gas	Propane	5,000 feet elevation		8,000 feet elevation		9,000 feet elevation	
			Natural gas	Propane	Natural gas	Propane	Natural gas	Propane
PG-25	N/R	3.5	n/a	n/a	n/a	n/a	n/a	n/a
PG-30	N/R	3.5	4.5	4.5	2.5	4.0	n/a	n/a
PG-35	N/R	3.5	4.5	3.5	3.5	3.75	n/a	n/a
PG-40	N/R	0	2	0	0	0	n/a	n/a
PG-45	N/R	0	0	0	0	0	0	0

n/a -Models not available.

N/R - Air Shutter not required. (For these units an adjustable air shutter is NOT supplied with the unit.)

SECTION XI - Start-Up Procedures

Final Checks Before Start-up

- Verify the PERFORMANCE and the primary and domestic systems are full of water and all system components are correctly set for operation.
- Verify Start-up Preparation items outlined on pages 49 thru 52 have been completed.
- Verify all electrical connections are correct and securely fasten.
- Inspect vent piping and combustion air inlet piping for signs of deterioration from corrosion, physical damage or sagging. Verify combustion air piping and vent piping are intact and correctly installed.
- Verify Burner Configuration - Propane Only.

Check for proper labeling on the gas valve, combustion air inlet and the rating label for propane configuration.

If there is doubt on the burner configuration, remove the gas valve and check for proper propane orifice. See Fig. 28 page 41. Refer to Propane Conversion Instructions for additional information on assembly of the gas valve.

- Adjustment of the Secondary Thermostat Limit.

The Secondary (Domestic) Thermostat located on left side of the control panel maintains the minimum domestic water storage temperature.

Set the thermostat knob as shown in Fig. 38 page 56.

Maximum limit setting is 140°F

PERFORMANCE Start-up

1. Turn the ON-OFF switch located on the front control panel to the OFF position. Turn the electrical supply or any external service switch to the unit in the ON position.

2. Read and follow the Operating Instructions outlined on page 54 to start the appliance.

If PERFORMANCE Does Not Start Correctly

1. Check for loose electrical connections, blown fuse or open service switch.
2. Check continuity across the Low Water Cut-Off device for close circuit.
3. Is the manual limit control open? Ensure the manual limit is reset to the close position.
4. Is the gas supply valve open at the unit and meter?
5. Is incoming gas supply pressure more than 5" w.c. for natural or propane with all gas appliances operating.
6. Are the heating thermostats set below room temperature?

If none of these conditions correct the problem, refer to the PERFORMANCE Trouble-shooting guide.

Check the PERFORMANCE and System

- Check Domestic Piping.

Check domestic piping and system components for leaks. If found, shut down the unit and repair immediately.

- Check Primary Piping.

Check primary system piping and components for leaks. If found, shut down the unit and repair immediately.

Purge any remaining air from the system piping. Air in the system piping will interfere with circulation creating heat distribution problems and system noise.

- Check Vent Piping and Combustion Air Piping.

Check for gas-tight seal at every connection and seam of the venting and combustion air inlet.



FOR YOUR SAFETY READ BEFORE LIGHTING

WARNING

The following instructions must be followed exactly, a fire or explosion may result causing property damage, personal injury or loss of life.

- A. This appliance is equipped with an electronic ignition system. Do not attempt to light the burner by hand.
- B. BEFORE OPERATING, smell all around the appliance area for gas. Be sure to smell next to the floor because some gas is heavier than air and will settle on the floor.
WHAT TO DO IF YOU SMELL GAS
 - Do not try to light any appliance.
 - Do not touch any electric switch; do not use any phone in your building
 - Immediately call your gas supplier from a nearby phone. Follow the gas supplier's instructions.
 - If you cannot reach your gas supplier, call the fire department.
- C. Do not use this appliance if any part has been under water. Immediately call a qualified service technician to inspect the appliance and to replace any part of the control system and any gas control which has been under water.

OPERATING INSTRUCTIONS

1. **STOP!** Read the safety information above.
2. Set the secondary thermostat to the lowest setting.
3. Turn manual shutoff valve on the gas supply line clockwise  to "Close"
4. Set the unit's "ON-OFF" switch to "OFF"
5. This appliance is equipped with an ignition device which automatically lights the pilot. Do not try to light the pilot by hand.
6. Turn manual shutoff valve on the gas supply line counter clockwise  to "Open"
7. Wait five (5) minutes to clear out any gas. If you smell gas, STOP! Follow "B" in the safety information stated above. If you don't smell gas, go to next step.
8. Set the unit's "ON-OFF" switch to "ON"
9. Set the secondary thermostat to the desired setting. See Page 56 for recommended thermostat settings.
10. If the appliance will not operate, follow the instructions "To Turn Off Gas To Appliance" and call your service technician or gas supplier.

TO TURN OFF GAS TO APPLIANCE

1. Set the system thermostat to lowest setting.
2. Turn the unit's "ON-OFF" switch to "OFF"
3. Turn manual shut-off valve on the gas supply line clockwise  to "Close".

WARNING

Venting system must be sealed gas-tight to prevent flue gas spillage and potential carbon monoxide emissions, which will result in severe personal injury or death.

- Check Gas Piping

Check around the unit for gas odor following the procedure outlined in this manual on Page 51.

WARNING

If any gas leaks are found or suspected, shut the unit down immediately. Use a gas detection device or bubble test to locate the source of the gas leak and repair at once. Do not operate the unit until the leak is corrected. Failure to comply with this procedure could result in severe personal injury, death or substantial property damage.

- Verify Flame Pattern and Combustion

Check the flame pattern through the inspection port of the burner. The flame should be blue and stable. The flame should be the length of the burner head openings.

Remove the test plug located on the flue hood and insert a combustion test probe.

Test for CO₂ or O₂ and for CO. The combustion reading should be within the range listed in Table 6. The CO level should not exceed 100 ppm when combustion is correct.

To adjust the combustion level open or close the air shutter by a 1/2 setting.

- Closing the air shutter will decrease the O₂ level and increase the CO₂ level.
- Opening the air shutter will increase the O₂ level and decrease the CO₂ level.

WARNING

A combustion test must be performed after any adjustments are made. Allow the unit to operate for approximately 10 minutes after adjustment before measuring any combustion levels. Failure to comply with these procedures could result in severe personal injury, death or substantial property damage.

Table 6: Recommended Combustion Levels

	Natural Gas	Propane
O ₂ Min.	3.00%	3.00%
O ₂ Max.	5.00%	5.00%
CO ₂ Min	9.00%	10.50%
CO ₂ Max	10.00%	12.00%

WARNING

Replace the test port plug when the combustion test is completed to prevent flue gas spillage into the building. Failure to comply with this procedure could result in severe personal injury, death or substantial property damage.

- Measure Input - Natural Gas Only

1. Operate the unit for approximately 10 minutes.
2. Turn off all gas appliances within the building.
3. At the gas meter, record the time required to use one cubic foot of gas.
4. Calculate gas input using the following equation:

$$3600 \times 1000 / \text{number of second recorded for one cubic of gas} = \text{BTU/H.}$$

5. The BTU/H calculated should approximate the input rating listed on the unit.

SECTION XII - Temperature Limits

DANGER

Studies have indicated that dangerous bacteria can form in the potable water distribution system if certain minimum water temperatures are not maintained. For prevention of this, it is recommended that the Secondary Thermostat be set as shown in Figure 38 and maintained at 130°F to 140°F.

Setting Primary Thermostat Limit.

- The Primary (Space Heating) Thermostat located on the right side of the control panel acts as the high limit during the space heating function.
- Set the thermostat knob as shown in Figure 39.
- Maximum limit setting is 180°F

NOTICE

To ensure proper function of the limits the Primary Thermostat must be set higher than the Secondary Thermostat.

Adjustment of Secondary Thermostat Limit

- The Secondary (Domestic) Thermostat located on left side of the control panel maintains the minimum domestic water storage temperature.
- Set the thermostat knob as shown in Figure 38.
- Maximum limit setting is 140°F.

NOTICE

To adjust the thermostat settings:

- Turn thermostat knob clockwise to increase water temperature
- Turn thermostat knob counter-clockwise to decrease water temperature.

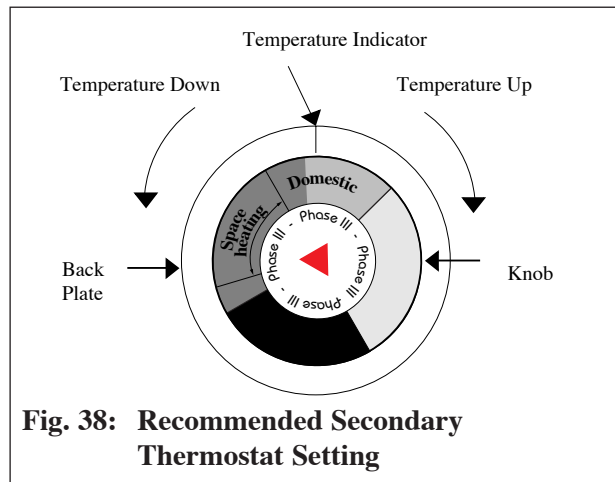

Fig. 38: Recommended Secondary Thermostat Setting

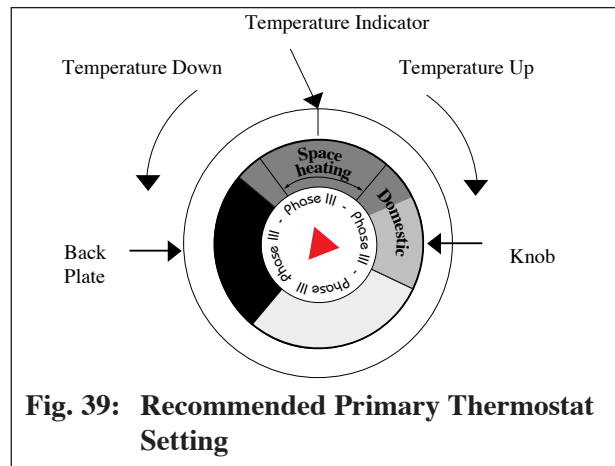

Fig. 39: Recommended Primary Thermostat Setting

□ Setting the Thermostatic Mixing Valve

NOTICE

The thermostatic mixing valve controls the outlet hot water temperature delivered to the faucets.

WARNING

POTENTIAL SCALD HAZARD The mixing valve must be installed on the **PERFORMANCE**. Removal of the mixing valve will create a potential scald hazard resulting in severe personal injury or death.

- Use a L-Key to remove the set screw securing the knob to the valve.
- Remove the knob and lock ring from the valve.
- Replace the knob and adjust the set temperature of the valve to the desired temperature.

NOTICE

To calibrate the outlet temperature, allow the water to run for approximately 2 minutes and measure the water with a thermometer. To adjust the valve setting, rotate the knob clockwise to decrease the water temperature or counter-clockwise to increase the water temperature.

- Once the desired temperature is achieved, remove the knob and refit the lock ring onto the valve aligning the ring indicator mark with the valve's "Mix" marking.
- Locate the tab on the inner face of the knob into the retainer in the locking ring. Secure the knob with setscrew.
- Record the valve performance on the Installation Record included in this manual.

DANGER

For proper operation of the thermostatic mixing valve, the manual valve on the U-tube assembly MUST remain open to avoid a potential scald hazard.

SECTION XIII- Check-Out Procedures

NOTICE

Perform the following check-out procedures as outlined and check off items as completed. When procedures are completed, the installer should complete the installation record on page 59.

Check-out Procedures

- Both inner and outer tanks filled with water.
- Water chemistry checked and verified as outlined on page 49.
- The automatic air vent on the unit and any place within the system are open one full turn.
- Air is purged from the heating zones and primary system.
- Domestic piping is purged of air and has been checked for leaks.
- Burner has been confirmed as properly configured for Propane application. (If applicable).
- Thermostat circuit wiring checked and verify that no voltage is present at the Room Thermostat Snap-set as outlined on page 52.
- Operating Instructions on page 54 were followed during start-up.
- Combustion levels and flame pattern verified as outlined on page 55.
- Measure the rate of input on Natural Gas as outlined on page 55.
- Check the incoming gas pressure to ensure a minimum pressure of 5" w.c during flow conditions to all appliances and a maximum pressure of 13" w.c during non-flow conditions for Natural and Propane.
- Primary and Secondary Thermostat properly set as shown in Figure 38 and 39 page 56.
- The thermostatic mixing valve adjusted to the desired domestic hot outlet temperature.
- Adjusted balancing valves and system limit controls to provide design temperatures to the primary space heating system.
- In multiple zone applications, adjusted for correct flow of primary heating water to each zone.
- Check and verify room thermostat functions properly and the thermostats heat anticipator (if used) was properly set.
- Observed several operating cycles for proper operation of the PERFORMANCE and the system.
- Set the room thermostat(s) to the desired room temperature.
- Reviewed all instructions shipped with the PERFORMANCE with the homeowner or maintenance personnel.
- Complete the Installation Record on page 59.
- Ensure all manuals and other documentation are returned to the Installation envelope and given to the owner for safekeeping.

SECTION XIV - Installation Record

PRESTIGE Model Number: _____

Serial Number: _____

Date of Installation: _____

Fuel: Natural Gas Propane

Measured Rate of Input: _____ Btu/hr

Combustion Readings:

CO₂ _____ %

O₂ _____ %

CO _____ ppm

The following items were completed during installation:

Installation instructions have been followed and completed

Check-out procedures have been followed and completed

Information regarding the unit and installation received and left with owner / maintenance
 personal.

Installer Information

(Company) _____

(Address) _____

(Address) _____

(Phone Number) _____

SECTION XV - Maintenance Schedule

Service Technician

At least on an annual basis the following maintenance should be performed by a qualified service technician:

General

- Attend to any reported problems.
- Inspect the interior of the combustion chamber; clean and vacuum if necessary.
- Clean the condensate trap in the vent system and fill with fresh water.
- Check for leaks; water, gas, flue and condensate.
- Verify flue vent piping and air inlet piping are in good condition and sealed tight.
- Check primary system water pressure/primary system piping/primary expansion tank.
- Check domestic water pressure/domestic system piping/domestic thermal expansion tank.
- Check domestic and primary thermostat settings.
- Check ignition electrode (sand off any white oxide; clean and reposition).
- Check ignition wiring and ground wiring.
- Check all control wiring and connections.
- Check burner flame pattern (stable and uniform) and flame.

Additional items if combustion or performance is poor:

- Clean baffles and flue ways.
- Remove burner assembly and clean burner head using compressed air only.

Once the maintenance items are completed, review the service with the owner.

Owner Maintenance

Daily:

- Check the area around the unit.
- Check the combustion air inlet and ventilation openings for blockage.
- Check the temperature/pressure gauge.

Monthly:

- Check vent piping.
- Check combustion air inlet piping.
- Check the pressure relief valve.
- Check the temperature/pressure relief valve.
- Check the vent condensate drain system.
- Check the automatic air vents in the primary system.

Every 6 months:

- Check both primary piping and gas supply piping for corrosion or potential signs of leakage.
- Operate the pressure relief valve.
- Operate the temperature/pressure relief valve.

Periodically:

- Check the operation of the domestic mixing valve.

WARNING

Follow the maintenance procedures given throughout this manual. Failure to perform the service and maintenance or follow the directions in this manual could result in damage to the PERFORMANCE or in system components, resulting in severe personal injury, death or substantial property damage.

SECTION XVI - Maintenance Procedures

MAINTENANCE PROCEDURES

WARNING

The **PERFORMANCE** should be inspected and serviced annually, preferably at the start of the heating season, by a qualified service technician. In addition, the maintenance and care of the unit as outlined on page 60 and further explained on pages 61 through 64 should be performed to assure maximum efficiency and reliability of the unit. Failure to service and maintain the **PERFORMANCE** and the system components could result in equipment failure, causing possible severe personal injury, death or substantial property damage.

NOTICE

The following information provides detailed instruction for completing the maintenance items outline in the maintenance schedule on page 60. In addition to this maintenance, the **PERFORMANCE** should be serviced at the beginning of the heating season by a qualified service technician.

Reported Problems

Any problems reported by the owner should be checked, verified and corrected before proceeding with any maintenance procedures.

Check the Surrounding Area

Verify that the area surrounding the **PERFORMANCE** is free of combustible / flammable materials or flammable vapors or liquids. Remove immediately if found.

is free of any contaminates. Refer to the list of potential materials listed on page 7 of this manual. If any of these products are in the

room from which the unit takes its combustion air, they must be removed immediately or the combustion air intake must be relocated to another area.

Inspect the Burner Area

Remove the burner hood and inspect the appearance of the burner components.

Vacuum any dirt or debris from the burner components.

Remove the venturi inlet elbow to check for dirt and debris. Remove any obstructions.

WARNING

Do not use solvents to clean any of the burner components. The components could be damaged, resulting in unreliable or unsafe operation.

Check System (Primary and Domestic) Piping

Inspect all piping on the Primary Heating system and the Domestic system for leaks and verify that the piping is leak free.

Inspect the fittings and components on the unit and verify they are leak free.

WARNING

Eliminate all primary water system leaks. Continual fresh make-up water will reduce the outer tank life causing tank failure. Leaking water may also cause severe property damage to the surrounding area.

Check Combustion/ Ventilation Air Openings

Verify that all combustion air and ventilation openings to the mechanical room or building are open and unobstructed. Check the operation and wiring of any automatic ventilation dampers.

Check and verify the vent discharge and the combustion air intake are free of debris and obstructions.

Inspect Vent System and Combustion Air Piping

Visually inspect the venting system and combustion air piping (if installed) for blockage, deterioration or leakage. Repair any vent joints that show signs of deterioration as per the vent manufacturer's instructions.

When combustion air is ducted to the unit, verify that the air inlet piping is connected and sealed. Inspect the air hose connecting the air inlet adapter to the venturi elbow for deterioration.

WARNING

Failure to inspect the vent system and combustion air inlet piping and have any deficiencies repaired, can result in severe personal injury or death.

Check Primary System

Verify all system components are correctly installed and operating correctly.

Check the cold fill pressure for the system. Typical cold water fill pressure is 12 psig.

Verify the system pressure as the unit operates at high temperature to ensure the pressure does not exceed 25 psig. Excessive pressure reading indicates expansion tank sizing is incorrect or system performance problems.

Inspect air vent and air separators in the system. Remove the caps on automatic air vents and briefly depress the valve stem to flush vent. Replace the cap when completed. Ensure vents do not leak, replace any leaking vents.

Check Domestic System

Verify all system components are correctly installed and operating correctly.

Check the outlet domestic temperature of the mixing valve and compare with the recorded temperature made during start-up.

Check Expansion Tank

Refer to Section V - Primary Piping for recommended location of the expansion tank and air eliminators.

Close -Type Tank:

- Ensure tank is partially filled with water leaving an air gap as a cushion. Refer to the manufacturer's instruction for proper fill level.
- Ensure the tank is fitted with a device that reduces gravity circulation of air-saturated tank water back into the system. This device prevents air from bubbling up through the water as it returns from the system.
- Ensure no automatic air vents are used in the system. This will allow air to escape from the system instead of returning to the tank.

Diaphragm Tank:

- Ensure the system contains a minimum of one automatic air vent. Preferred location of the air vent should be atop an air eliminator.
- Remove the tank from the system and check the charge pressure. For residential applications the charge pressure is typically 12 psig. If tank does not hold a charge pressure, then the membrane is damaged and the tank should be replaced.

Check Boiler Relief Valve

Inspect the relief valve and lift the lever to verify flow at least annually or as recommended on the warning tag of the valve.

WARNING

Before manually operating the pressure relief valve, ensure the discharge piping is directed to a suitable place of disposal to avoid a potential scald hazard. The discharge piping must be full size without restriction and installed to permit complete drainage of both the valve and line.

If after closing the valve, the valve fails to seat properly or continually weeps, replace the relief valve. Ensure the cause of the relief valve to weep is the valve itself, not due to system over-pressurization caused by an expansion tank that is waterlogged or undersized.

Check Temperature / Pressure Relief Valve

Inspect the T&P relief valve and lift the lever to verify flow at least annually or as recommended on the warning tag of the valve.

WARNING

Before manually operating the pressure relief valve ensure the discharge piping is directed to a suitable place of disposal to avoid a potential scald hazard. The discharge piping must be full size without restriction and installed to permit complete drainage of both the valve and line.

If after closing the valve, the valve fails to seat properly or continually weeps, replace the relief valve. Ensure the cause of the weeping is the valve itself and not due to thermal expansion or a faulty or under-pressurized thermal expansion tank.

Inspection of Ignition Electrode

Remove the ignition electrode from the burner mounting plate.

Remove any white oxides accumulated on the electrode using fine grit sandpaper or steel wool. If the electrode does not clean to a satisfactory condition, replace the ignitor.

When replacing the ignition electrode, ensure the gasket is in good condition and correctly positioned.

Check Ignition Wiring and Ground Wiring

Inspect the burner wiring from the burner control module to the ground terminal behind the control panel.

Ensure wiring is in good condition and securely connected.

Check ground continuity of the wiring using a continuity meter.

Replace and correct ground wire if ground continuity is not completed and satisfactory.

Check Control Wiring

Inspect all control wiring located behind the control panel and at the burner control module. Ensure wiring is in good condition and properly connected.

Check Thermostat Limit Settings

Check the position of the Secondary and Primary Thermostat knobs, refer to Figure 38 and 39 page 56 for recommended settings.

Perform Start-up and Checkout Procedures

Start the unit and perform the start-up procedure as listed in this manual.

Verify the cold water fill pressure is correct and the operating pressure of the primary system is within normal operating range.

Complete the checkout procedures as referenced in this manual.

Check Burner Flame

Inspect the burner flame through the observation port on the burner mounting plate.

If flame pattern is not fully blue and covers the entire burner surface, shut the unit down and allow it to cool thoroughly.

Close the manual gas valve on the gas supply line and disconnect the gas piping to remove the burner assembly from the unit.

Remove the burner head mounting screws and remove the burner head. Inspect the head for deterioration. Use compressed air or a vacuum to clean the burner head.

Remove the venturi and gas valve assembly from the blower.

Use the vacuum cleaner or compressed air to clean the interior of the blower assembly. Inspect the blower blades to ensure they are clean and not damaged.

Re-assemble the venturi and gas valve onto the blower. Ensure the venturi gasket is in good condition and positioned correctly.

Re-assemble the burner head onto the mounting plate. Ensure the burner head gasket is in good condition and positioned correctly.

Re-assemble the gas supply connection and open the manual gas valve placing the unit back into service.

Flame Signal

The flame signal should be at least 0.6 μ A. Refer to the PERFORMANCE Troubleshooting Guide for information on checking the flame signal.

Check the ignitor for fouling or damaged insulation if a low flame signal is read.

Check ground wiring and continuity as a cause for low flame signal. Replace ignitor if found and continuity conditions are unsatisfactory.

Check Combustion Levels

Refer to page 55 of this manual for measuring combustion levels and burner adjustments.

Review With Owner

Ensure the owner understands the importance to perform the maintenance schedule specified in this manual.

Remind the owner of the importance to call a licensed contractor should the unit or system exhibit any unusual behavior.

SECTION XVII - Replacement Parts

Replacement Parts

WARNING

Replacement parts can be ordered and purchased through a local Triangle Tube distributor. When ordering parts, specify the Model Number and Serial Number. Include a description of the part and a replacement part number. Using modified or other manufacturer parts will not be covered by warranty and may damage or cause improper function of the unit.

NOTICE

Refer to pages 66 and 69 for description and replacement part numbers.

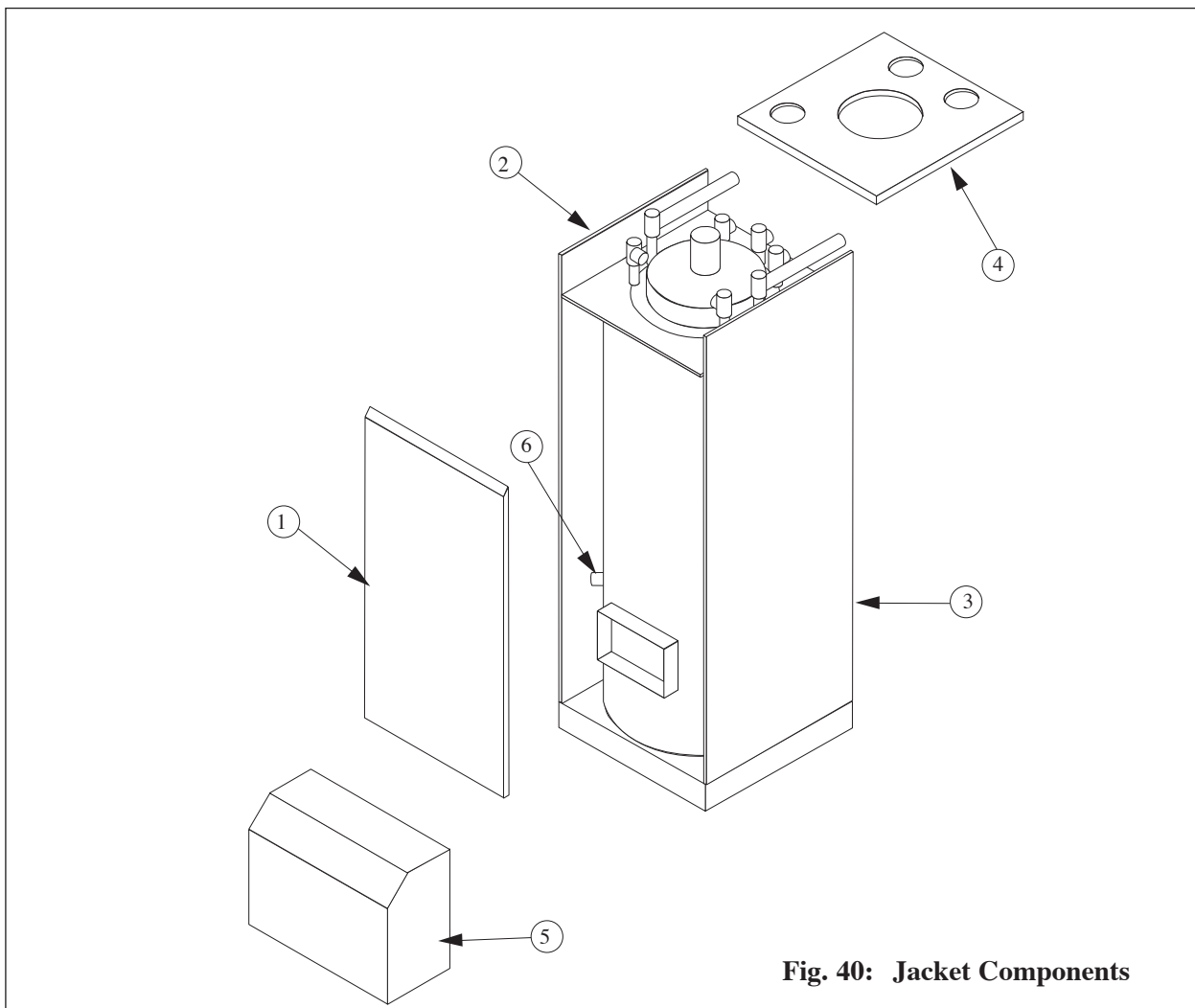

Fig. 40: Jacket Components

Item	Part No.	Description	Quantity required by Model	
			PG 25/ 30/35	PG 40/45
	HMJKTF25	Complete Jacket Set	1	
	HMJKTF35	Complete Jacket Set		1
1	HMJKT25F	Jacket, Front	1	
	HMJKT35F	Jacket, Front		1
2	HMJKT25L	Jacket, Left side	1	
	HMJKT35L	Jacket, Left side		1
3	HMJKT25R	Jacket, Right side	1	
	HMJKT35R	Jacket, Right side		1
	HMJKT25B	Jacket , Back	1	
	HMJKT35B	Jacket , Back		1
4	HMJKT25TOP	Jacket, Top cover	1	
	HMJKT35TOP	Jacket, Top cover		1
5	HMHO06	Burner Jacket Hood	1	1
6	PGRKIT20	Low Water Cut-Off Device LWCO	1	1

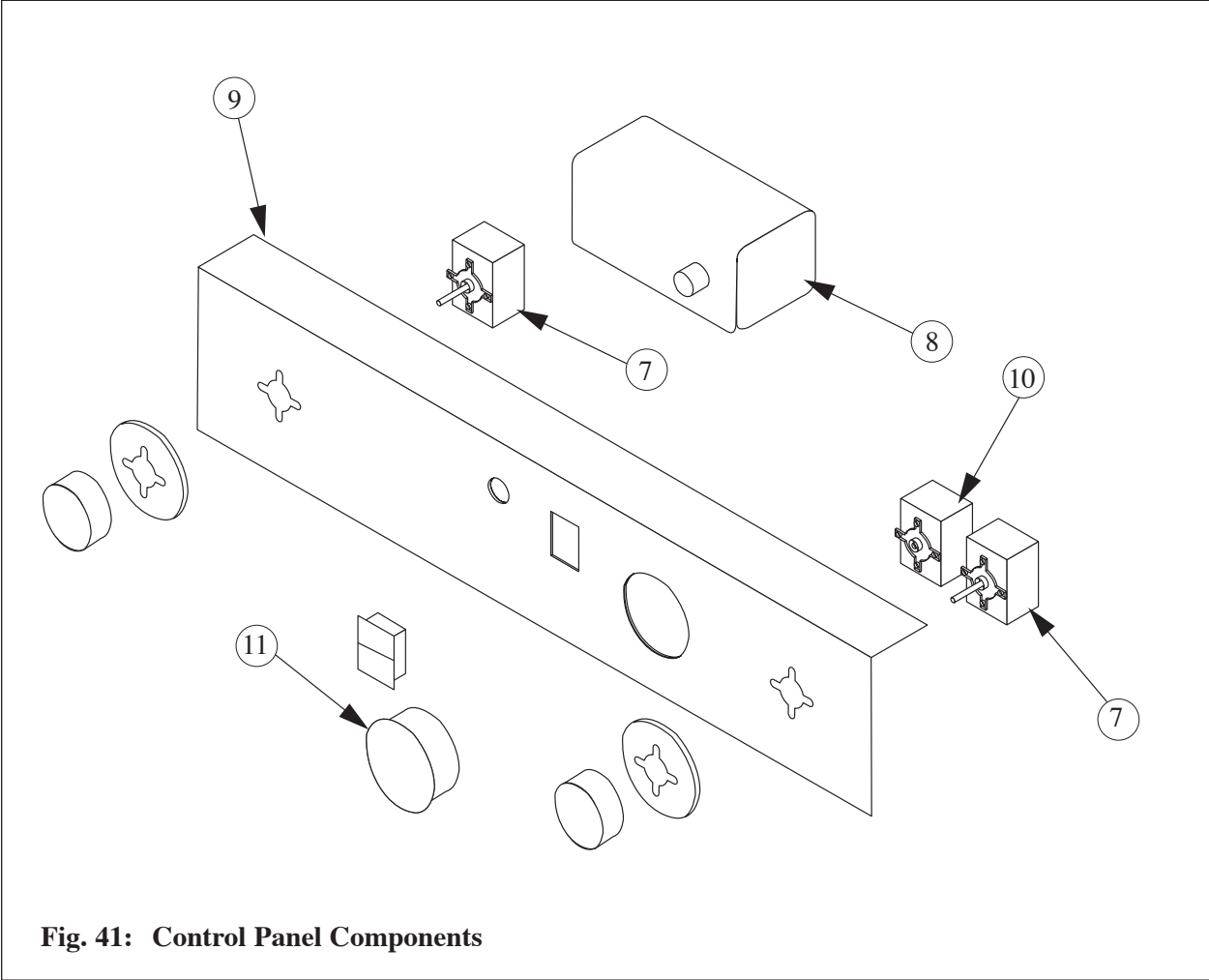

Fig. 41: Control Panel Components

Item	Part No.	Description
7	PGRKIT21	Operating Thermostat Primary or Secondary
8	PGRKIT 22	Manual Reset Hight Limit Pre-set at 205°F
9	HMCS01	Control Panel
10	PGRKIT23	Auto Reset High Limit Pre-Set at 194°F
11	HMGAU01	Temperature / Pressure Gauge

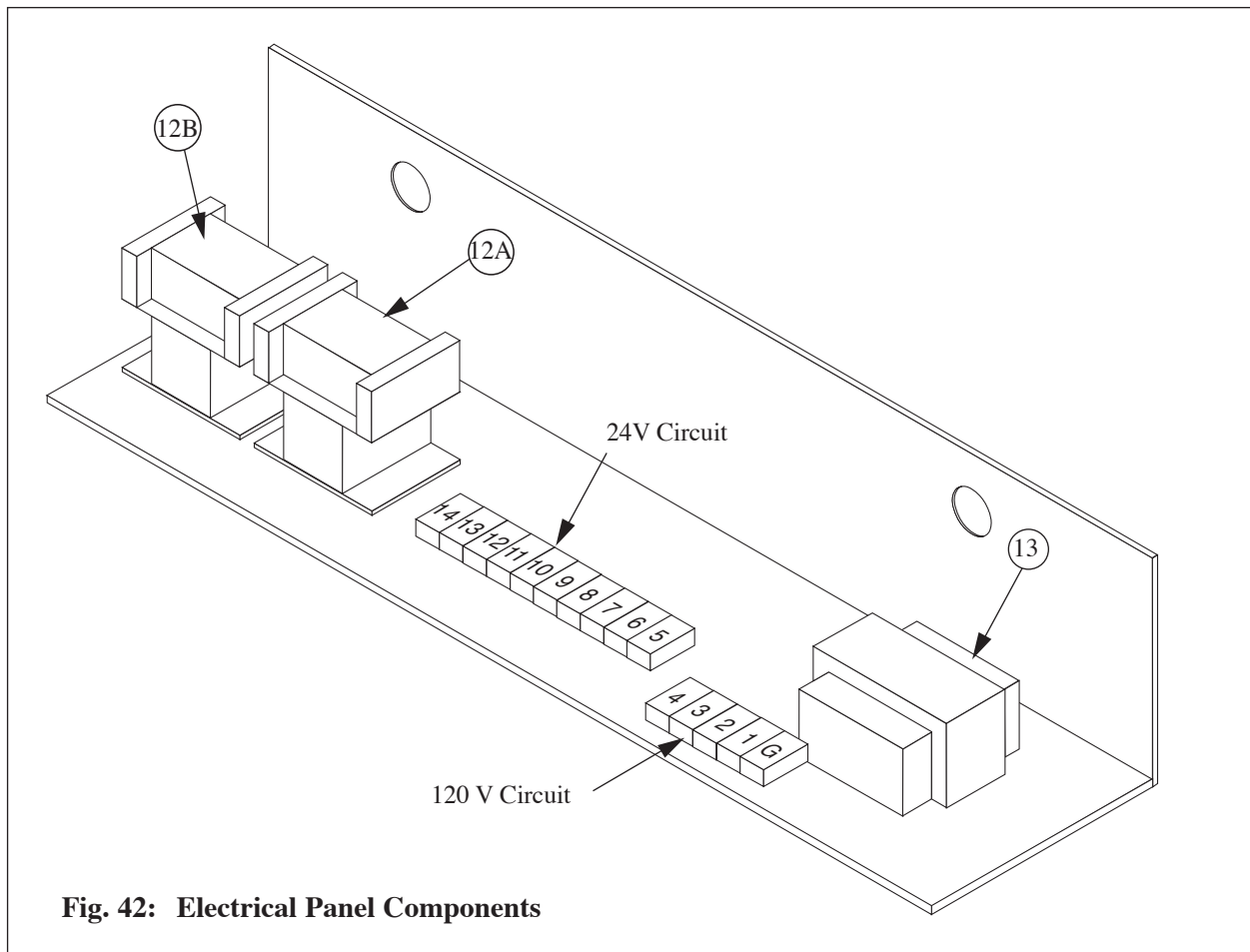
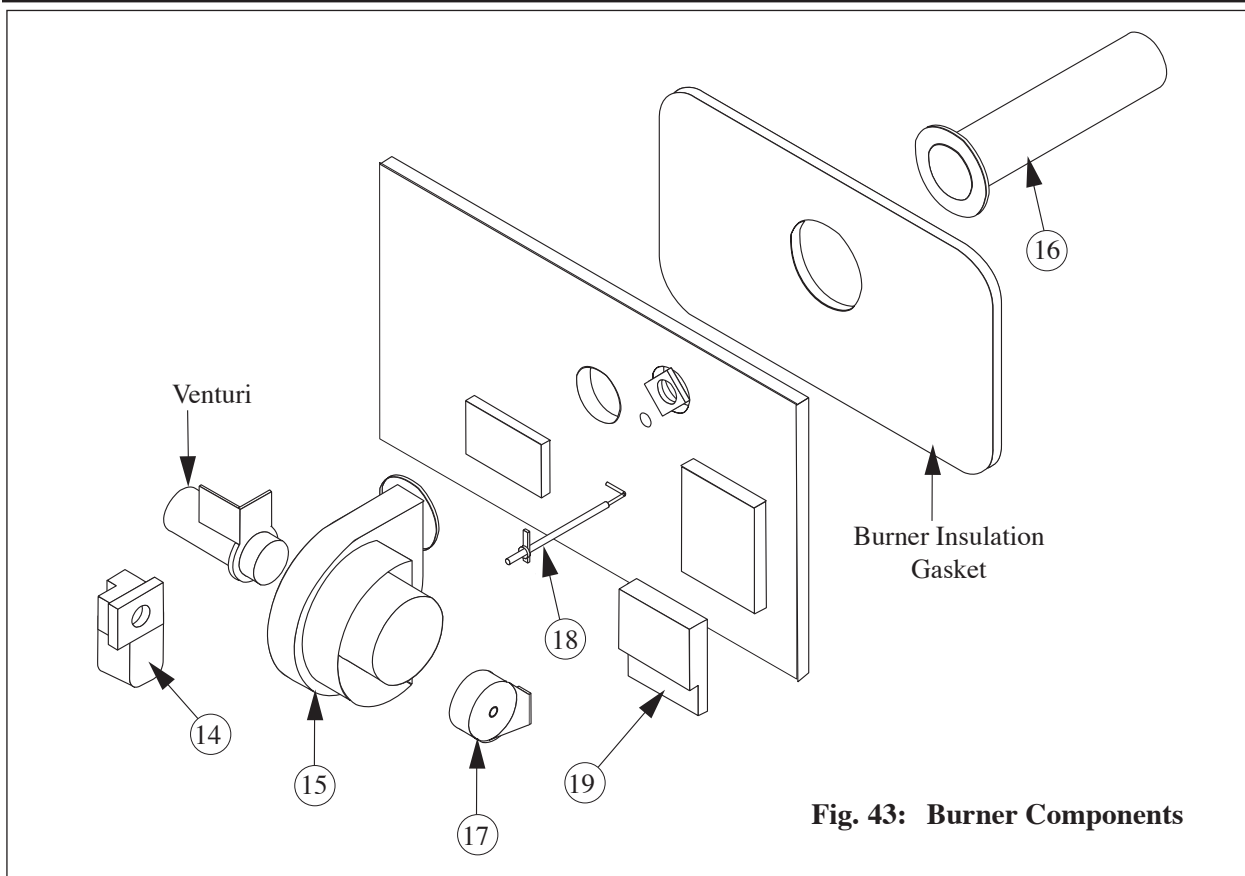

Fig. 42: Electrical Panel Components

Item	Part No.	Description
12A	PGRKIT19	R1 Relay - Controls Burner Function
12B	PGRKIT 19	R2 Relay - Controls Domestic Priority & Circulator
13	PGRKIT18	120 V-24 V 40VA Transformer

Part No.	Description
HMRLV01	Pressure Relief Valve 30 psi
P3AVT01	Air Vent
HMVLV07	Thermostatic Mixing valve 3/4"
HNSNP02	Snap sets Male / Female
HMTPV01	Temperature/Pressure Relief Valve (PG-30/35/40/45 only)
HMTPV03	Temperature/Pressure Relief Valve (PG-25 only)



Item	Part Number	Description	Where Used
14	PGRKIT01	Gas valve replacement kit	ALL
15	PGRKIT02	PG-25 Blower / motor replacement kit	PG-25
	PGRKIT03	PG-30 Blower / motor replacement kit	PG-30
	PGRKIT04	PG-35 Blower / motor replacement kit	PG-35
	PGRKIT05	PG-40 Blower / motor replacement kit	PG-40
	PGRKIT06	PG-45 Blower / motor replacement kit	PG-45
	17	PGRKIT11	Pressure switch replacement kit with 1.84" w.c. pressure switch
PGRKIT12		Pressure switch replacement kit with 2.7" w.c. pressure switch	
PGRKIT13		Pressure switch replacement kit with 3.35" w.c. pressure switch	
18	PGRKIT14	Ignitor replacement kit	PG-25/30/35
	PGRKIT17	Ignitor replacement kit	PG-40/45
19	PGRKIT16	UT Ignition control module replacement kit	ALL

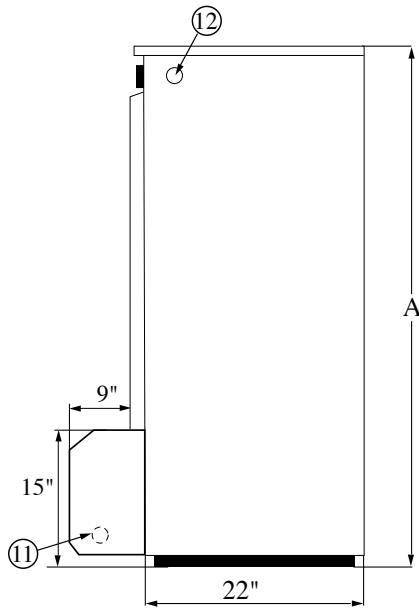

Fig. 44: Side View

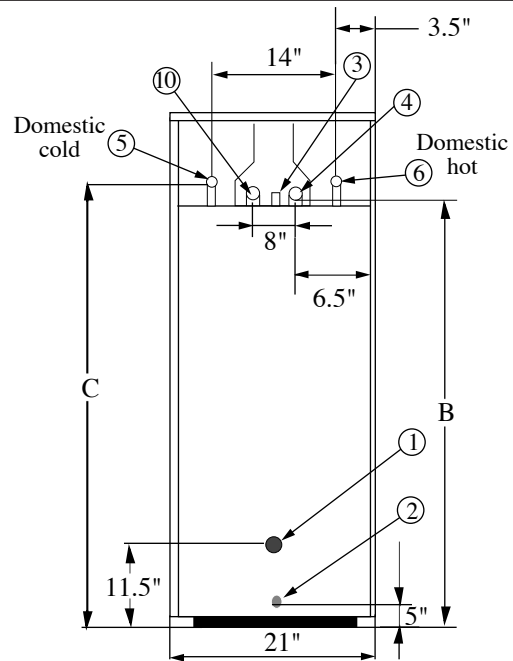

Fig. 45: Rear View

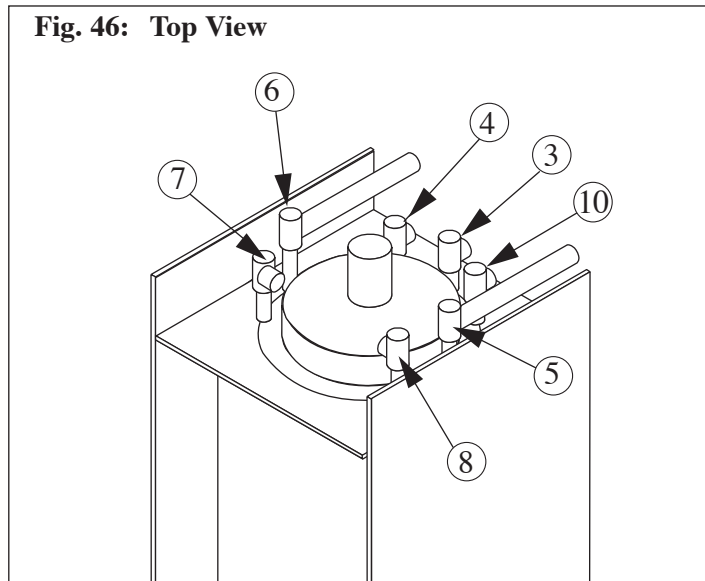

Fig. 46: Top View

- | | |
|--|--|
| <ol style="list-style-type: none"> 1. Primary circuit, ϕ 1" NPT 2. Primary circuit drain valve connection, ϕ 1/2" NPT 3. Domestic temperature/pressure relief valve (150 psi), ϕ 3/4" NPT 4. Primary circuit & pressure relief valve (30 psi), ϕ 1" NPT 5. Domestic cold water inlet, ϕ 3/4" NPT 6. Hot water outlet & secondary thermostat sensor, ϕ 3/4" NPT | <ol style="list-style-type: none"> 7. Manual reset safety sensor & pressure indicator sensor, ϕ 3/4" NPT 8. Primary thermostat sensor, temperature indicator sensor and automatic reset safety sensor, ϕ 1/2" NPT 9. L.W.C.O. pressure sensor, ϕ 1/2" NPT (shown as item 6 on page 66) 10. Primary circuit & air vent, ϕ 1" NPT 11. Gas Supply 12. 120 V Electric Supply |
|--|--|

Table 7: Dimensional Data

Type		PG-25	PG-30	PG-35	PG-40	PG-45
Input Nat. Gas	Btu/hr	100,000	120,000	140,000	165,000	199,000
Inner Tank Capacity	Gal	20	20	20	22	22
Outer Tank Capacity	Gal	22	22	22	18	18
Dimensions	Inches					
A		59	59	59	67	67
B		54	54	54	62.5	62.5
C		54.5	54.5	54.5	63.5	63.5
Vent outlet size		3	3	3	3	3
TP Valve (domestic)	∅	3/4"	3/4"	3/4"	3/4"	3/4"
Domestic water	∅	3/4"	3/4"	3/4"	3/4"	3/4"
Primary connection	∅	1 "	1 "	1 "	1 "	1 "
Drain	∅	1/2"	1/2"	1/2"	1/2"	1/2"
Empty weight	lb	345	345	345	485	485
Heat exchanger surface	Sq. Ft.	17	17	17	26.5	26.5

Table 8: PERFORMANCE Data

Model	10 Min. Peak Flow (gallons)	1st Hour Rating (gallons)	Continuous Flow @ 80°F Rise (gph)	Combustion Efficiency (%)	AFUE (%)	Heating Capacity MBH
PG-25	56	163	128	84.0	82.7	84
PG-30	61	188	153	84.0	82.7	101
PG-35	65	214	179	83.3	82.0	112
PG-40	74	249	210	84.9	84.5	140
PG-45	81	292	254	84.5	84.1	168

Graph 1: PERFORMANCE Pressure Loss - Primary Side

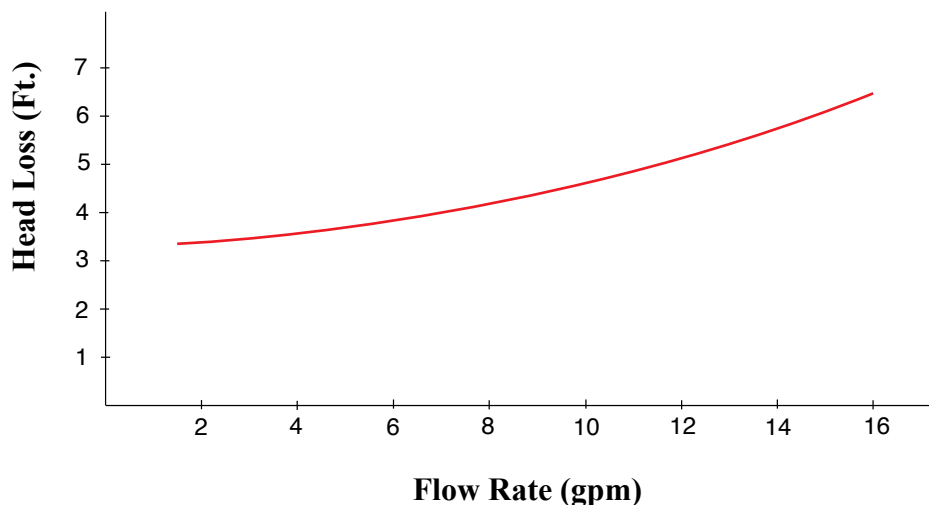

**Additional quality water heating equipment available
from
Triangle Tube/Phase III**

Phase III Indirect Fired Water Heaters



- Exclusive Tank-in-Tank design
- Stainless steel construction
- Available in 8 sizes and 2 models
- Limited LIFETIME residential warranty
- 15 year limited commercial warranty
- Self cleaning/self descaling design
- 2" polyurethane insulation

TTP Brazed Plate Heat Exchangers



- For domestic water, snow melting, radiant floor, refrigeration
- Plates made of stainless steel, with a 99.9 % copper and brazed, ensuring a high resistance to corrosion
- Self cleaning and self descaling
- Computerized sizing available from Triangle Tube/Phase III
- Available in capacities from 25,000 BTU/hr to 5,000,000 BTU/hr

Maxi-flo Pool and Spa Heat Exchangers



- Construction of high quality corrosion resistant stainless steel (AISI 316)
- Also available in Titanium
- Specially designed built-in flow restrictor to assure maximum heat exchange
- Compact and light weight
- Available in 5 sizes that can accommodate any size pool or spa



Freeway Center - 1 Triangle Lane - Blackwood, NJ 08012
Tel: (856) 228 8881 - Fax: (856) 228 3584
<http://www.triangle-tube.com>
E-mail: Info@triangle-tube.com

