

# Instinct Igniter Replacement



Kit Part Number	Description	Model
INSRKIT27	Igniter Replacement	All Instincts

## Each Kit Includes:

- Igniter
- Igniter Gasket
- Screws (2)

## Recommended Tools:

- Phillips Head Screwdriver

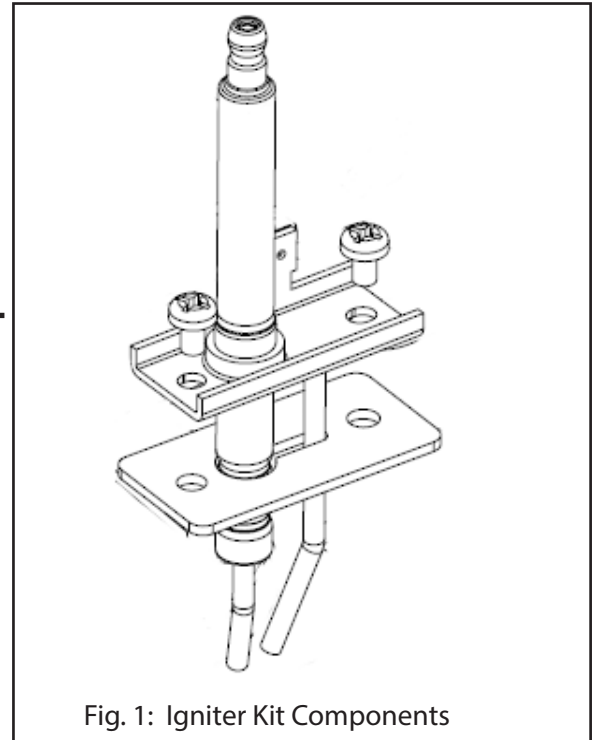

Fig. 1: Igniter Kit Components

## WARNING

Indicates a potentially hazardous situation which, if ignored, can result in serious injury or substantial property damage.

## NOTICE

Indicates special instructions on installation, operation or maintenance, which are important to equipment but not related to personal injury hazards.

## WARNING

For your safety, turn off electrical power supply at service panel and allow unit to cool before proceeding to avoid possible electrical shock and scald hazard. Failure to do so can cause severe personal injury or death.

## WARNING

Failure to follow instructions below can result in severe personal injury or damage if ignored.

- Instructions are for a qualified installer/ service technician only.
- Read all instructions before proceeding.
- Follow instructions in proper order.

# Instinct Igniter Replacement



## 1. Preliminary Instructions

1. Verify that the igniter is correct for the model of boiler. See table on page 1.
2. Carefully open and unpack the PARTS BOX from its shipping carton. Check for any damage.

5. Verify the igniter gap is approximately 1/8.

6. With the gasket in place reassemble the igniter to the burner mounting plate ensuring the ground wire tab is reinstalled. First, evenly hand tighten the Torx screws then torque to 27-31 inch-pounds. Be careful not to over tighten.



**Installing the igniter with a damaged gasket increases the potential risk of a gas leak. Any potential gas leakage may result in serious injury, substantial property damage or death.**



**Installing the igniter without the grounding tab will leave the boiler not properly grounded and may result in serious injury, substantial property damage or death.**

### NOTICE

*Installing a damaged igniter will cause malfunction of the boiler. Contact Triangle Tube right away if the igniter is damaged in any way.*

### NOTICE

*The mounting hole for the Igniter/Sensor is keyed and will only allow the igniter to be installed in the proper orientation.*

3. Turn off the electrical power supply to the boiler.
4. Close the manual gas shut off valve to the unit.

7. Attach the other ground wire to the Igniter tab.
8. Attach the ignition cable to the new igniter.
9. Turn power to the unit "ON".

## 2. Instructions

1. Turn power to the unit "OFF".
2. Disconnect the black ignition cable from the ignitor.
3. Keep the ground wire attached to the tab on the screw. Remove the ground wire from the other Igniter tab.
4. Unscrew the igniter to the burner mounting plate. Discard the old Igniter and gasket.

10. Perform 3 to 4 ignitions and verify that the unit lights normally.
11. Reinstall the front cover and place the unit back in service.

### NOTICE

*If the gasket "sticks" to the mounting plate use a flat blade putty knife to remove any gasket material. Make sure not to scratch or score the mating surface.*

### NOTICE

*For the reassembly process do not use adhesives on ANY gasket surface.*