

the **HAMWORTHY**

# BRAZED PLATE HEAT EXCHANGER

## 60kW

Perfect for refurb  
and retrofit  
situations

Compact design

Low maintenance  
and self-cleaning

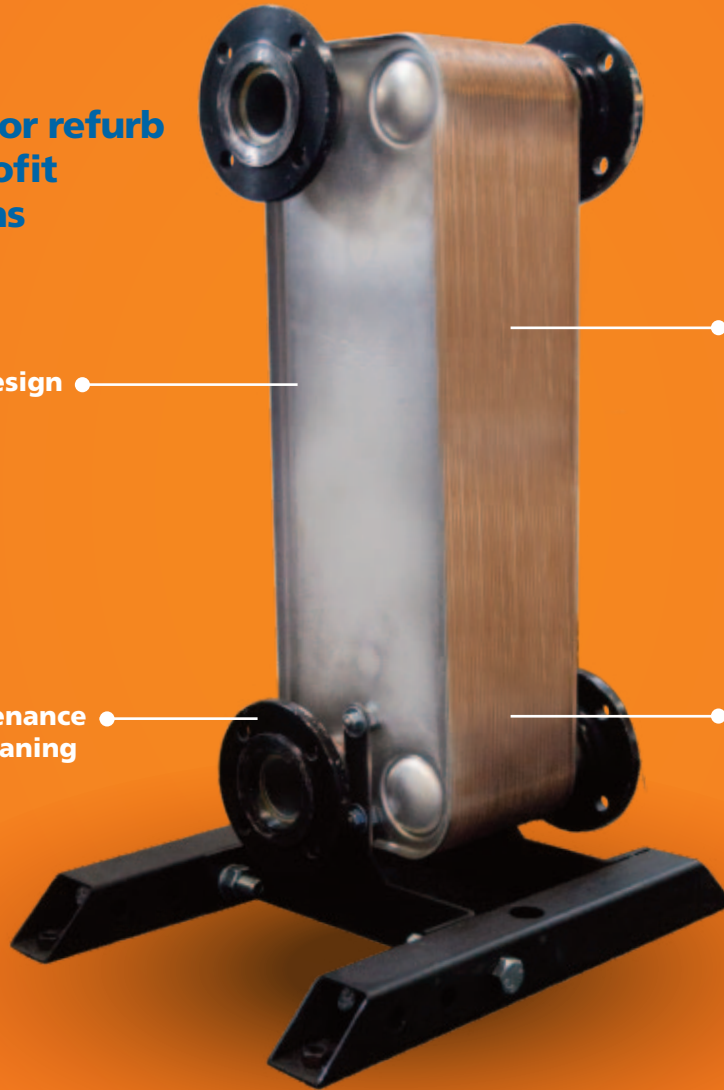

Separates system  
water from the boiler

Used with Hamworthy  
Heating Cascade kits



SCAN  
ME

**ASK**  
advice. specification. knowledge.

**h** **Hamworthy**

# Brazed Plate Heat Exchanger – 60kW



60kW is the nominal capacity of the plate heat exchanger applying the operating conditions shown below. Please contact Hamworthy Heating to confirm the expected performance if the operating conditions differ from those shown.

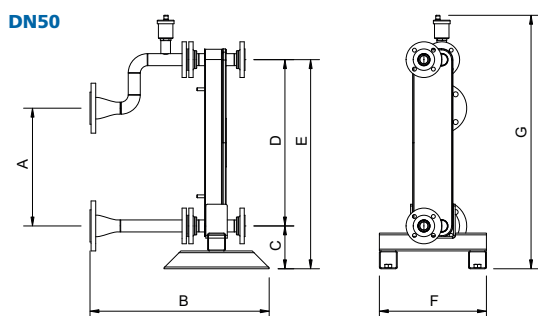

## Installed dimensions

Dimension	A	B	C	D	E	F	G	Installed weight (including PHE, spools and support)
DN50	330	500	120	466	586	300	716	DN50 Kit = 20kg

	UNITS	HOT SIDE	COLD SIDE
Mass flow rate	kg/s	0.72	0.72
Inlet temperature	°C	80	50
Outlet temperature	°C	60	70
Pressure drop	kPa	14.0	19.3
Heat exchanged	kW	60	
Heat transfer area	m <sup>2</sup>	1	
Flow configuration	Countercurrent		
Number of plates / thickness	20 / 0.3 mm		
Number of passes		1	1
Pressure vessel code	PED		
Design pressure at 90.00 Celsius	Bar	40	40
Design pressure at 225.0 Celsius	Bar	32	32
Design temperature	°C	-196.0 / 225.0	
Overall length x width x height	mm	??? x ??? x ???	
Volume	L	1.0	0.9

## Standard materials

Cover plates	Stainless steel
Connections	Stainless steel
Plates	Stainless steel
Brazing	Copper

PLEASE NOTE:  
The plate heat exchangers are to be used for system separation only.  
They must not be used for the direct production of domestic hot water.

They should not be used for direct heating of swimming pool water where the chlorinated pool water would pass directly through the plate heat exchanger.

## Connections

### FRAME & HEADER

Stratton mk3	DN50	DN80	DN100
	✓		
<b>System</b>			
DN25			
<b>Flanged</b>			
PN6			