



# Prestige Solo 155 - 175 - 250

## Natural Gas to Propane Conversion Instructions

These instructions shall be kept with the appliance literature for future reference.

### **WARNING**

Do not use the appliance with propane gas unless these Conversion Instructions have been fully implemented.

This conversion kit shall be installed by a qualified installer, service agency, or the gas supplier in accordance with the manufacturer's instructions and all applicable codes and requirements of the authority having jurisdiction.

If the information in these instructions is not followed exactly, a fire, an explosion, or production of carbon monoxide can result causing property damage, personal injury, or loss of life.

The qualified installer, service agency, or the gas supplier is responsible for the proper installation of this kit. The installation is not proper and complete until the operation of the converted appliance is checked as specified in this manufacturer's instructions supplied with the kit.

### **NOTICE**

*Whenever possible, conversion should be carried out before installing and connecting the boiler.*

### **DEFINITIONS**

The following terms are used throughout this manual to bring attention to the presence of potential hazards or to important information concerning the product.

### **WARNING**

Indicates a potentially hazardous situation which, if ignored, can result in substantial property damage, serious injury, or death.

### **DANGER**

Indicates the presence of a hazardous situation which, if ignored, will result in substantial property damage, serious injury, or death.

### **NOTICE**

*Indicates special instructions on installation, operation or maintenance, which are important to the equipment but not related to personal injury hazards.*

Triangle Tube

1240 Forest Parkway, Suite 100, West Deptford NJ 08066  
Tel: (856) 228 8881 - Fax: (856) 228 3584 E-mail: info@triangletube.com

# PRESTIGE SOLO 155 - 175 - 250 - NATURAL GAS TO PROPANE CONVERSION INSTRUCTIONS

## ATTENTION

This appliance was converted on \_\_\_\_\_/\_\_\_\_\_/\_\_\_\_\_ (day/month/year)  
 Cet appareil a été converti le \_\_\_\_\_/\_\_\_\_\_/\_\_\_\_\_ (année/mois/jour)

pour fonctionner au gaz \_\_\_\_\_ gas (gas type)  
 à l'aide de la trousse n° \_\_\_\_\_ (reference number)

Combustion readings  
 Valeurs de combustion: \_\_\_\_\_% CO<sub>2</sub>    \_\_\_\_\_% O<sub>2</sub>    \_\_\_\_\_ppm CO

by \_\_\_\_\_  
 par \_\_\_\_\_

Name and address of organization making this conversion - nom et adresse de l'organisme qui a effectué la conversion

**that accepts the responsibility for the correctness of this conversion  
 qui accepte l'entière responsabilité de la qualité de la conversion**

---

**ATTENTION**

THIS GAS CONTROL VALVE HAS BEEN CONVERTED FOR USE WITH PROPANE GAS

A1010458 - A

**ATTENTION**

CETTE COMMANDE/VANNE GAZ A ÉTÉ CONVERTIE POUR FONCTIONNER AU GAZ PROPANE

Affix this conversion plate as close as possible to the existing rating plate  
 Collez cette plaque de conversion aussi près que possible de la plaque signalétique existante

WARNING

**THIS APPLIANCE WAS CONVERTED FROM NATURAL GAS TO PROPANE**

- Ensure the propane gas orifice and label have been installed on gas control valve.
- Verify combustion readings are within the desired range specified in the PRESTIGE Conversion Instructions or Installation Manual.

AVERTISSEMENT

**CET APPAREIL A ÉTÉ CONVERTI DU GAZ NATUREL AU PROPANE**

- Assurez-vous que la commande/vanne gaz est munie de l'orifice et de l'autocollant pour le fonctionnement au gaz propane.
- Vérifiez que les valeurs de combustion se situent dans la plage souhaitée, spécifiée dans les instructions de conversion ou le manuel d'installation des appareils PRESTIGE.

PRESTIGE	80	110	155	175	250	299	399
Conversion kit Trousse de conversion	PARKIT 62	PARKIT 63	PARKIT 64	PARKIT 65	PARKIT 66	TCRKIT 26	
Max/min inlet gas pressure Pression maxi/mini d'alim. gaz			13"WC MAX. 5"WC MIN.				
Manifold pressure Pression collecteur	0.04"WC						
Input rating Puissance	See existing rating plate Consulter la plaque signalétique existante						

Made in Belgium

**A. Installer's conversion data label**

To be filled in by the installer with relevant information and affixed close to the rating plate

**B. Conversion label for gas control valve (EN / FR)**

To be affixed on top of the gas control valve to indicate that conversion has been performed.

**C. Propane gas rating plate**

To be affixed close to the existing rating plate.

Fig. 1 - Conversion Label Sheet

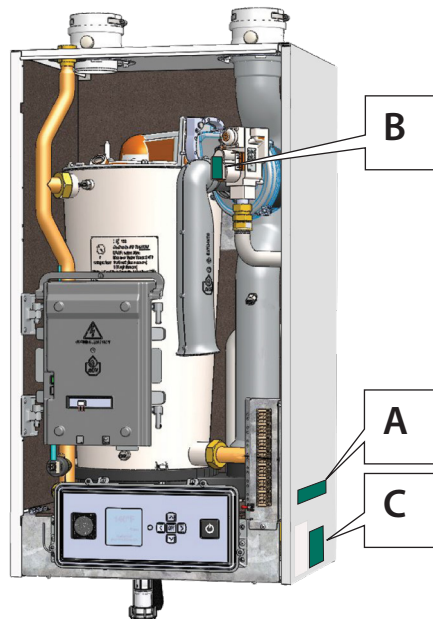

Fig. 2 - Location of Labels after Conversion

## Scope:

These instructions cover NG to LP conversion for PRESTIGE Solo 155, 175 and 250 boilers only. Each kit is supplied with one orifice suitable for use with that particular boiler model.

## Kit Part Number:

Prestige Solo 155 :	PARKIT64
Prestige Solo 175 :	PARKIT65
Prestige Solo 250 :	PARKIT66

## Kit Contents:

- Propane Conversion kit labels (Refer to *Fig. 1 and Fig. 2 on page 2*):
  - A. Installer's conversion data label
  - B. Conversion label for gas control valve
  - C. Propane gas rating plate
- Propane gas orifice
- Gasket (Venturi-gas control valve)
- Gasket (gas pipe connection)
- T-25 Torx Wrench

Table 1 - Propane Gas Orifices

Model	Orifice size
P155	0.205 inch (5.2 mm)
P175	0.232 inch (5.9 mm)
P250	0.250 inch (6.3 mm)

## 1.1. Applicability

P155 - P175 - P250 boilers - Serial Numbers starting with PA and subsequent (PB, PC, etc.)

## 1.2. Safety requirements



Failure to follow instructions provided in this document can result in substantial property damage, serious injury, or death.

- **Instructions are for a qualified installer or service technician.**
- **Read all instructions before proceeding.**
- **Follow instructions in proper order.**
- **Make sure that the correct gas type is used.**

## 1.3. Kit Installation

### NOTICE

*Upon completion of the conversion from Natural Gas (NG) to Propane gas (LP):*

- *Affix the new propane gas rating plate (C) included in the kit adjacent to the existing rating label. DO NOT affix the new label over the existing rating label.*
- *Affix propane conversion label (B) to the gas control valve.*
- *Fill in and affix the Installer conversion data label (A)*
- *Refer to Fig. 2 on page 2 for correct locations.*

### 1.3.1 Required Tools and Material

- Adjustable Wrench
- Phillips Screwdriver
- Flat-blade Screwdriver
- T-25 Torx Wrench
- Calibrated Combustion Analyzer

### 1.3.2 Procedure

1. Turn the boiler off by pressing the power switch located at the front of the unit.



**For your safety:**

- **The gas supply shall be shut off prior to disconnecting the electrical power, before proceeding with the conversion,**
  - **The electrical power supply shall be turned off at external electric box prior to performing any operation on the internal parts of the boiler.**
  - **Failure to do so can result in substantial property damage, serious injury, or death.**
2. Shut off the gas supply to the boiler at the main manual shut off valve.
  3. Disconnect electrical power at the external electric box.
  4. Disconnect gas connection at the bottom of the boiler.
  5. Remove the front panel by removing the screws along the bottom edge of the unit.
  6. Pull the bottom of the panel forward and then lift up to remove the front panel from the unit.

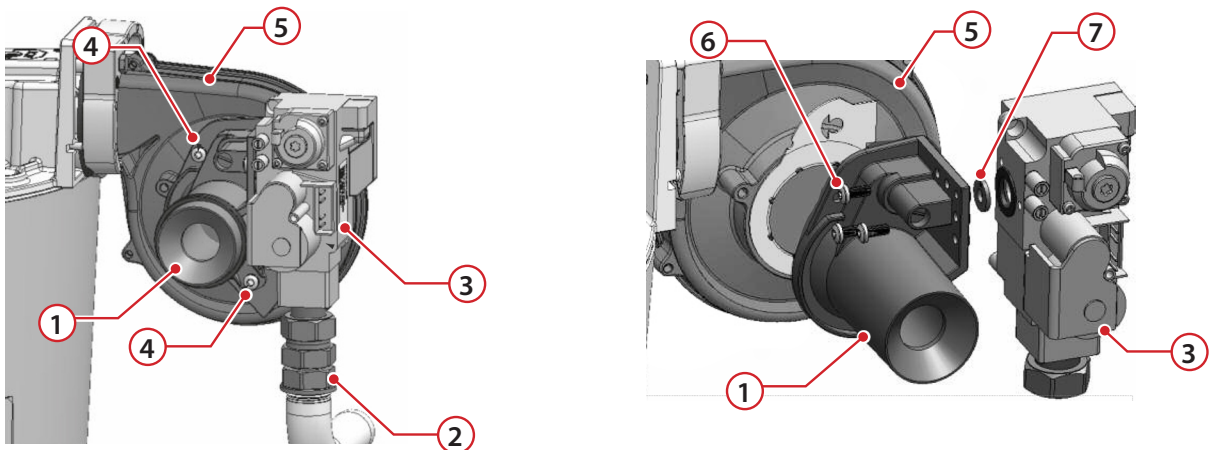

Fig. 3 - Boiler Components

7. Remove the air inlet elbow from the Venturi (1) using a twist and pull motion.
8. Disconnect the gas supply piping inside the Prestige enclosure at the nut (2) located on the bottom of the gas control valve (3). Remove and discard gasket.

**WARNING**

**The gasket between the gas control valve and the gas piping shall be replaced by a new one, provided in the kit when the gas piping is reconnected onto the gas control valve. Failure to do so can result in substantial property damage, serious injury, or death.**

9. Remove Molex plug from gas control valve (3).
10. Release two T-25 Torx-head screws (4) that secure the venturi/gas control valve assembly to the blower (5).

**NOTICE**

*The gasket between the Venturi and the blower must be reinstalled when the Venturi is mounted back onto the blower. Use care not to damage the gasket.*

11. Remove the two screws (4) the Venturi/gas control valve assembly and gasket from the blower (5). Retain all for reinstallation.
12. Using a T-25 Torx wrench remove the three mounting screws (6) attaching the gas control valve (3) to the Venturi (1). Also remove and discard gasket.

**WARNING**

**A new gasket, provided in the kit, shall be installed between the Venturi and the gas control valve when the gas control valve is installed back on the Venturi. Failure to do so can result in substantial property damage, serious injury, or death.**

13. Note the orientation of the gas control valve (3) to the Venturi (1) for later reference, to reassemble gas control valve (3) and Venturi (1).
14. Install the correct brass propane orifice (7) (See *Table 1 on page 3*) in the gasket between the gas control valve and the Venturi. The black rubber gasket must remain attached to the gas control valve.

**WARNING**

- **Failure to retain the rubber gasket on the gas control valve will cause an improper seal between the gas control valve and the venturi resulting in a potential risk of a gas leak. Any potential gas leakage can result in substantial property damage, serious injury, or death.**
  - **Ensure the proper orifice for the model is installed per *Table 1 on page 3*. Failure to comply will affect input rate and combustion of the boiler which can result in substantial property damage, serious injury, or death.**
15. Install the gas control valve (3) onto the Venturi (1) using the three T-25 Torx-head screws (6). Ensure the correct position of the gas control valve with respect to the Venturi.

16. Place the conversion label **(B)** on the gas control valve (refer to *Fig. 2 on page 2* for the correct location).

**ATTENTION**  
**THIS GAS CONTROL VALVE HAS BEEN CONVERTED FOR USE WITH PROPANE GAS**

17. Install the Venturi/gas control valve assembly to the blower **(5)**, with the gasket, using the two T-25 Torx-head screws **(4)**.

**NOTICE**

- *For the reassembly process do not use adhesive on the Venturi/blower gasket.*
  - *Use care in the reassembly of the Venturi/gas control valve assembly to the blower not to cross thread the mounting screws. Support the weight of the venturi/gas control valve assembly when threading the mounting screws.*
18. Reconnect Molex plug to the gas control valve electrical connection.
19. Ensure the gas control valve/piping gasket is in place, reconnect the gas piping connection **(2)**.
20. Reattach the air inlet elbow to the Venturi **(1)**.
21. Install the front panel back in place and secure with screws.
22. Make sure that the correct gas type is supplied to the boiler.
23. Make sure that the correct gas pressure is supplied to the boiler. See the Propane Gas Rating Plate Label for the required pressure (refer to *Fig. 1 on page 2*)
24. Open the manual gas shut off valve.
25. Before placing the Prestige boiler back into operation check and test all gas connections for leaks. Repair leaks if found.

**1.4. Starting Up the Boiler.**



- **Prior to start-up and during initial operation, check for a gas leak using a combustible gas detector. Do not proceed with the start-up if there is any indication of a gas leak. Any leaks found must be repaired immediately.**
- **Do not check for gas leaks with an open flame. Use a bubble test. Failure to check for gas leaks can result in substantial property damage, serious injury, or death.**
- **Propane installations only - The propane supplier mixes an odorant with the propane to make its presence detectable. In some cases the odorant can fade and the gas may no longer have an odor.**
- **Prior to start-up of the unit and periodically after start-up have the propane supplier check and verify the odorant level.**
- **Failure to comply with these instructions can result in substantial property damage, serious injury, or death.**

1. Visually check the overall installation.
2. Set room thermostat(s) to lowest setting. Turn the external manual gas valve handle clockwise  to "CLOSE" (valve handle must be perpendicular to gas piping).
3. Set the ON/OFF switch on the appliance control panel OFF.
4. Remove the front jacket panel on the unit.
5. Wait five (5) minutes to clear out any gas. If you then smell gas in the jacket enclosure or around the unit, STOP!



**If any gas leaks are found or suspected :**

- **Shut the unit down immediately.**
  - **Use a gas detection device or bubble test to locate the source of the gas leak and repair at once.**
  - **Do not check gas leaks with an open flame.**
  - **Do not operate the unit until the leak is corrected.**
  - **Failure to comply with this procedure will result in substantial property damage, serious injury, or death.**
6. If you don't smell gas, go to the next step.

# PRESTIGE SOLO 155 - 175 - 250 - NATURAL GAS TO PROPANE CONVERSION INSTRUCTIONS

7. Turn the external manual gas valve handle counter clockwise  to "OPEN" gas supply (valve handle shall be parallel to gas piping).
8. Check around the unit for gas odor. If you then smell gas in the jacket enclosure or around the unit, STOP! Refer to step 5.
9. Set the ON/OFF switch on the appliance control panel "ON".

## 1.4.1 Changing the Appliance Code.



**To ensure the correct operation of the appliance with propane gas, changing the appliance code is required. The appliance will then operate with factory preset fan speeds, adjusted to the gas type. Failure to do so can result in substantial property damage, serious injury, or death.**

1. Access the Installer menu as follows :

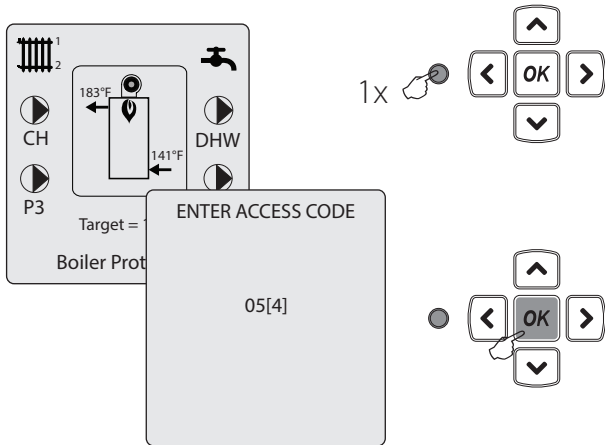

2. Go to the Boiler Settings page as shown below:

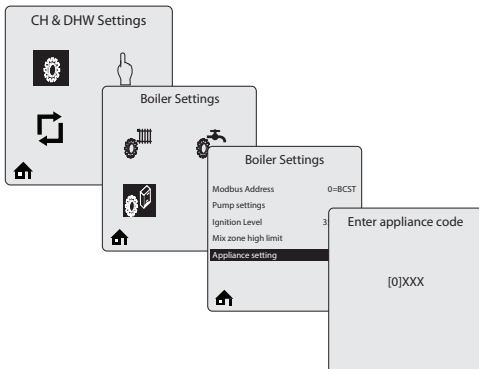

3. Insert the correct appliance code:

Prestige Solo 155 (LP): **B132**

Prestige Solo 175 (LP): **B142**

Prestige Solo 250 (LP): **B152**

4. Confirm the code by pressing **OK**, then follow the instructions displayed on the screen.
5. The software will then process the change and return to the Home screen.
6. Set room thermostat(s) to desired setting(s).
7. The appliance display will show the current operating status at the bottom of the screen. "Standby" means there is no call for heat (all thermostats are satisfied). "CH Demand" indicates a space heating call has been received. "DHW Demand" indicates a domestic hot water call has been received.
8. The ignition sequence will start. Make sure the fan operates a prepurge function prior to activating the ignitor. The boiler should then ignite properly.
9. A flame icon will be displayed when the unit is fired.



**1.5. Combustion Test and Adjustments**

**NOTICE**

*In case of problems at startup, first ensure that the correct appliance code was used.*

The installer **SHALL** perform a complete combustion check to ensure the combustion levels in *Table 2* are met at high and low input firing rates and the burner is operating at optimum conditions.

**WARNING**

- The combustion testing and adjustments must be performed by a qualified installer, service agency or the gas supplier. All combustion measurements must be performed with calibrated equipment to ensure proper readings and accuracy.
- Failure to perform a complete combustion test at both high and low input rates may result in incomplete combustion and the production of carbon monoxide, which can result in substantial property damage, serious injury, or death.
- The combustion levels should be measured at high firing rate. If the combustion levels are not within the range given in Table 2 for Low Fire after adjusting High Fire, shut the boiler down and contact Triangle Tube Technical Support Department. Failure to comply with this requirement can result in substantial property damage, serious injury, or death.
- The gas control valve outlet pressure is factory set to the correct value and does not require field adjustment or measurement. Measurement or adjustments could result in damage to the gas control valve and can result in substantial property damage, serious injury, or death.

1. In the Installer menu, select the Manual operation menu
2. Press the **OK** button while the **FAN** icon is highlighted to manually fire the burner and power the CH1 circulator.
3. Press the **RIGHT** button to adjust the firing rate to **100%** (high fire). Hold down the **RIGHT** button to rapidly increase the firing rate.

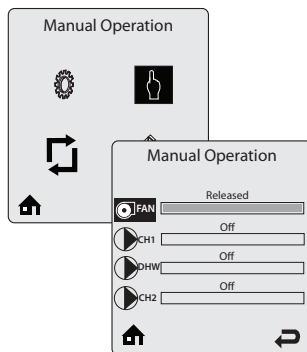

4. If the combustion levels during high fire are outside the recommended combustion settings adjust the Throttle screw (1) using a flat-blade screwdriver, as follows:
  - Counter-clockwise adjustment of the Throttle screw (1) at High Fire (100% firing rate): **O<sub>2</sub> decreases and CO<sub>2</sub> increases.**
  - Clockwise adjustment of the Throttle screw (1) at High Fire (100% firing rate): **O<sub>2</sub> increases and CO<sub>2</sub> decreases.**

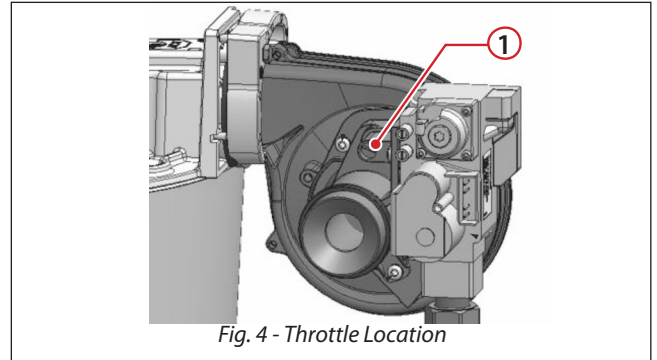

**NOTICE**

*An adequate CH load must be present to dissipate the heat generated during the combustion test. If an adequate CH load is not available an indirect water heater can be used to dissipate the heat by creating a DHW call which will enable the DHW circulator.*

5. Check the flame pattern through the observation port of the heat exchanger. The flame should be blue and stable. The flame should be over the length of the burner head.
6. Once the combustion level is set at high fire, manually place the boiler into low fire mode by pressing the **LEFT** button to adjust firing rate down to **1%** (low fire) to verify low fire combustion settings.

# PRESTIGE SOLO 155 - 175 - 250 - NATURAL GAS TO PROPANE CONVERSION INSTRUCTIONS

- If the combustion levels (O<sub>2</sub> & CO<sub>2</sub>) during low fire are outside the recommended combustion settings in **Table 2**, contact Triangle Tube Technical Support Department for assistance.

Table 2 - Required Propane Combustion Settings

Target values:	CO <sub>2</sub>	O <sub>2</sub>	CO
High Fire (HF)	11.0%	4.2%	150 ppm
Low Fire (LF)	10.4%	5.1%	0 ppm

## NOTICE

In exceptional cases, the following is allowed :

- HF: within the 10.7 to 12.0% range CO<sub>2</sub> (2.7 to 4.7% range O<sub>2</sub>).
- LF: 0.5 to 0.6% Lower than H.F. CO<sub>2</sub> (0.8 to 0.9% Higher than H.F. O<sub>2</sub>).
- CO contents shall always remain below 300ppm.

## 1.6. Measure Input - Propane Gas

### NOTICE

This section can only be performed when gas meter is present.

- Press the **OK** button while the **FAN** icon is highlighted and Press the **RIGHT** button to adjust the firing rate to **100%** (high fire).
- Operate the unit for approximately 10 minutes.
- Turn off all gas appliances within the building, except the PRESTIGE Solo.
- At the gas meter, record the time required to use one cubic foot of gas.
- Calculate propane gas input using the following equation:  
 $3600 \times 2500 / \text{number of seconds recorded for one cubic foot of gas} = \text{BTU/H.}$
- The BTU/H calculated should approximate the input rating listed on the unit data plate.
- Press the **OK** button while the fan icon is highlighted to shutdown the burner.
- Press the **LEFT** or **RIGHT** button to highlight the home screen icon  and exit the service mode.

## 1.7. Follow-on tasks

- Fill in the Installer's conversion data label (**A**) with the required conversion information and with combustion values.
- Affix filled in Installer's conversion data label (A) and Propane rating label (**C**) (refer to **Fig. 2 on page 2** for the correct location).

## NOTICE

Once conversion is completed, check input ratings for sea level applications according to table below. The boiler automatically derates the input at approximately 2% for every 1,000 Ft. of altitude. No alterations to the boiler or burner system are required.

Boiler Model	Gas	Input	DOE Heating Capacity	Net AHRI Rating	AFUE
Solo 155	Natural Propane	27,800 - 153,000	142,000	123,000	95%
Solo 175	Natural Propane	30,900 - 170,000	157,000	137,000	95%
Solo 250	Natural Propane	43,600 - 240,000	222,000	193,000	95%