

the **HAMWORTHY**

BRAZED PLATE HEAT EXCHANGER

450kW

Perfect for refurb
and retrofit
situations

Compact design

Low maintenance
and self-cleaning

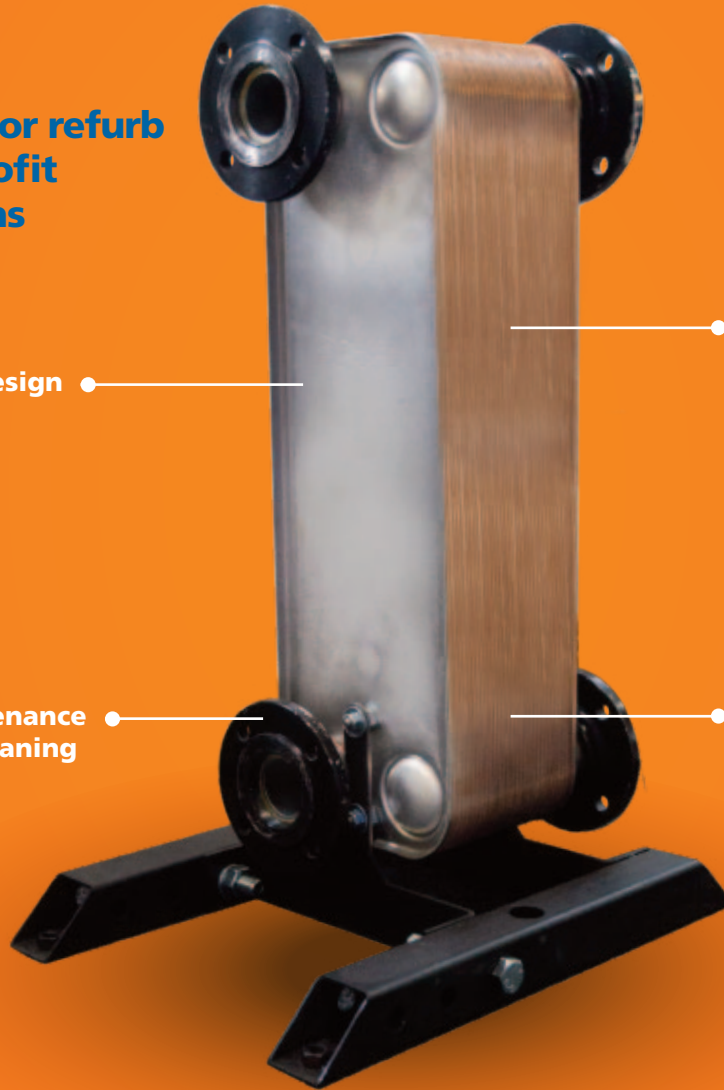

Separates system
water from the boiler

Used with Hamworthy
Heating Cascade kits



SCAN
ME

ASK
advice. specification. knowledge.

Hamworthy

Brazed Plate Heat Exchanger – 450kW



450kW is the nominal capacity of the plate heat exchanger applying the operating conditions shown below. Please contact Hamworthy Heating to confirm the expected performance if the operating conditions differ from those shown.

DN80 &
DN100

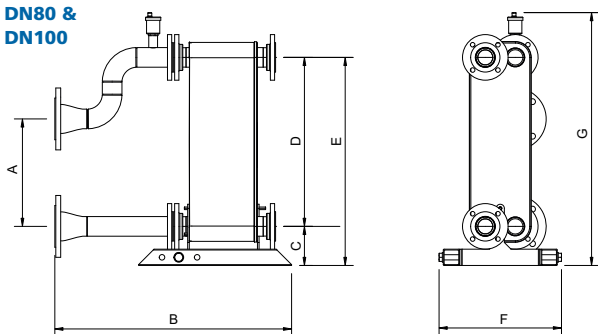

Installed dimensions

Dimension	A	B	C	D	E	F	G	Installed weight (including PHE, spools and support)
DN80	330	726	120	519	639	350	782	DN80 Kit = 57.5kg
DN100	330	739	120	519	639	350	782	DN100 kit = 57.5kg

	UNITS	HOT SIDE	COLD SIDE
Mass flow rate	kg/s	5.39	5.39
Inlet temperature	°C	80	50
Outlet temperature	°C	60	70
Pressure drop	kPa	12.9	13.5
Heat exchanged	kW	450	
Heat transfer area	m ²	8.3	
Flow configuration	Countercurrent		
Number of plates / thickness	76 / 0.3 mm		
Number of passes		1	1
Pressure vessel code	PED		
Design pressure at 90.00 Celsius	Bar	30	30
Design pressure at 225.0 Celsius	Bar	25	25
Design temperature	°C	-196.0 / 225.0	
Overall length x width x height	mm	??? x ??? x ???	
Volume	L	8.0	7.8

Standard materials

Cover plates	Stainless steel
Connections	Stainless steel
Plates	Stainless steel
Brazing	Copper

PLEASE NOTE:
The plate heat exchangers are to be used for system separation only.
They must not be used for the direct production of domestic hot water.

They should not be used for direct heating of swimming pool water where the chlorinated pool water would pass directly through the plate heat exchanger.

Connections

FRAME & HEADER

Stratton mk3	DN50	DN80	DN100
		✓	✓
System			
DN50			
Flanged			
PN6			

hamworthy-heating.com

sales@hamworthy-heating.com | 01202 662500

