

# Exalt Condensate Pan Replacement



Kit Part Number	Description	Model
EXRKIT98	Condensate Pan Replacement	Exalt 110
EXRKIT99	Condensate Pan Replacement	Exalt 155 Models
EXRKIT100	Condensate Pan Replacement	Exalt 199 Models

### Each Kit Includes:

- Condensate Pan
- Heat Exchanger Gasket
- Flue Tube Gasket

### Recommended Tools:

- Adjustable Wrenches
- Phillips Head Screwdriver
- T-25 Torx Screwdriver
- 8 mm Open Ended Wrench
- 10 mm Socket and/or 10 mm Open Ended Wrench



Indicates a potentially hazardous situation which, if ignored, can result in serious injury or substantial property damage.



Indicates special instructions on installation, operation or maintenance, which are important to equipment but not related to personal injury hazards.



For your safety, turn off electrical power supply at service panel and allow unit to cool before proceeding to avoid possible electrical shock and scald hazard. Failure to do so can cause severe personal injury or death.



Failure to follow instructions below can result in severe personal injury or damage if ignored.

- Instructions are for a qualified installer/ service technician only.
- Read all instructions before proceeding.
- Follow instructions in proper order.

# Exalt Condensate Pan Replacement



## 1. Preliminary Instructions

1. Verify that the replacement kit is correct for the model of boiler. See table on page 1.
2. Carefully open and unpack the PARTS BOX from its shipping carton.
3. Carefully remove and check for any damage.

### NOTICE

Installing damaged components will cause malfunction of the boiler. Contact IdealUSA right away if the repair kit is damaged in any way.

4. Turn off the electrical power supply to the boiler.
5. Close the manual gas shut off valve to the unit.

## 2. Drain Boiler

1. Make sure the power to the unit "OFF" and allow unit to cool.
2. Close all isolation valves on the system piping to the boiler. Close the fill valve line to the system.
3. Connect a garden hose to the boiler drain.
4. Direct the hose to a suitable place of drainage. Ensure boiler drain connection is between the boiler and the closed isolation valve.
5. Open the drain valve and begin draining the boiler.

### NOTICE

To assist in the draining of the boiler, remove the air vent at the top of the unit or manually lift open the pressure relief valve.

### WARNING

**Water from the boiler drain connection may be extremely hot. To avoid personal injury, death or substantial property damage:**

- Tighten all drain hose connections to avoid leakage.
- Direct hot water away from all persons.

## 3. Removal of the Burner Assembly

1. Remove front jacket panel of the boiler by loosening the one phillips screw on the bottom of the front jacket. Do not discard this screw as it will be reused.
2. Disconnect all the wires from the gas valve, blower and igniter.

### NOTICE

Mark the proper location of all wires before removing them.

3. Remove the silicone tube from the air inlet elbow. Keep the silicone tube attached to the gas valve.

### WARNING

**Inspect the silicone tube to ensure it is not damaged. Contact IdealUSA right away if the tube is damaged in any way.**

4. Remove the air inlet elbow from the venturi.
5. Unscrew the nut on both sides of the gas valve. Do not discard the gaskets as they will be reused.

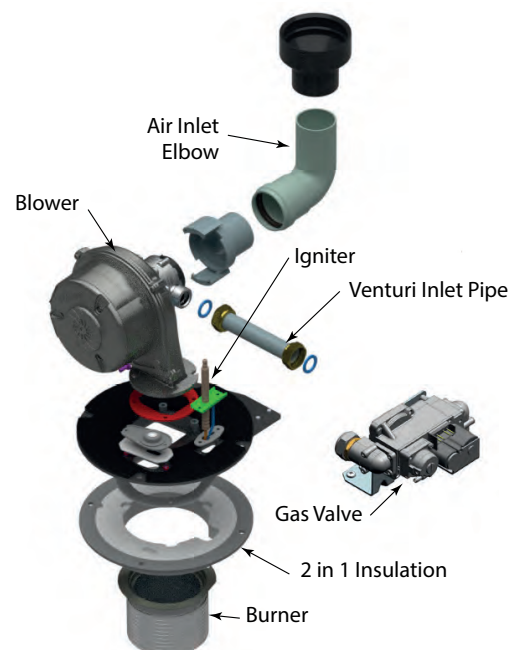

Fig. 1: Exalt 110 Burner Assembly

# Exalt Condensate Pan Replacement

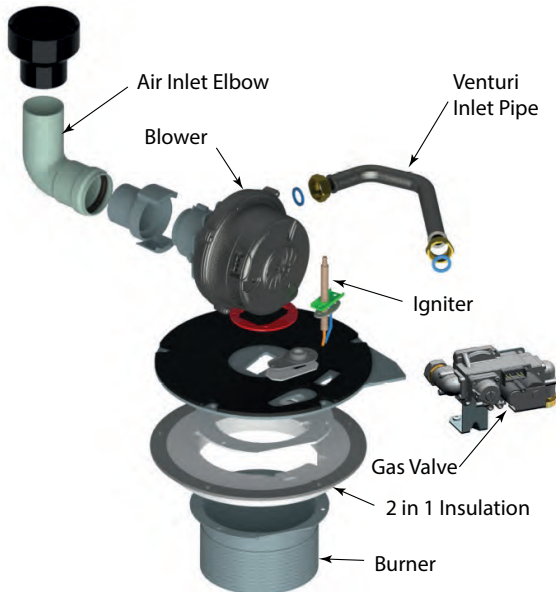

Fig. 2: Exalt 155 Burner Assembly

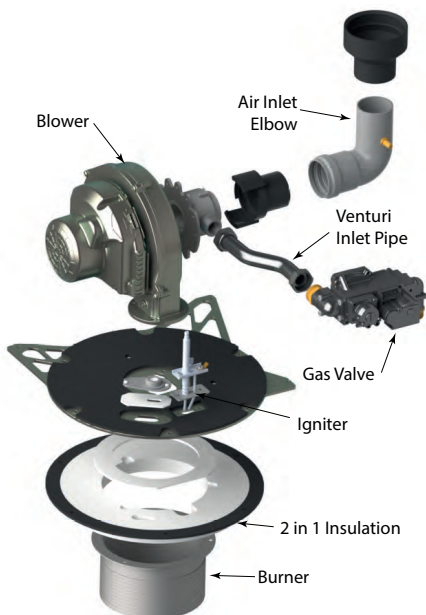

Fig. 3: Exalt 199 Burner Assembly

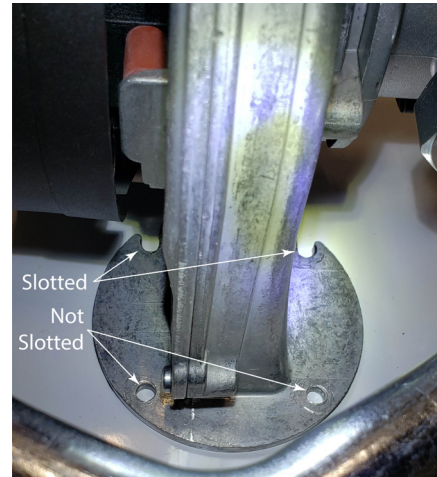

Fig. 4: Blower Bolt Holes

7. The two hard to reach bolt holes under the blower housing are slotted, see Fig. 4. Fully remove the two other 8mm bolts securing the blower to the burner mounting plate. Unscrew the other two bolts only as much as is needed to remove the blower/venturi assembly.
8. Slide the blower/Venturi forward to disengage the rear bolts and remove the blower/venturi from the boiler. Do NOT discard the blower gaskets. Do NOT discard the bolts as they will be reused.



**WARNING**  
Inspect the blower and venturi to ensure they are not damaged. Contact IdealUSA right away if either is damaged in any way.

9. Remove the two Phillips head screws securing the burning mounting plate to the rear jacket panel. These screws are for shipping protection and can be discarded.
10. Remove the 10 mm burner plate mounting nuts mounting the plate to the heat exchanger. Do not discard the nuts as they will be reused.
11. Lift the combustion chamber insulation and burner mounting plate together. Remove the insulation/burner straight up from the heat exchanger body to ensure the igniter and burner head are not damaged.



**WARNING**  
Inspect the gas valve to ensure they are not damaged. Contact IdealUSA right away if damaged in any way.

# Exalt Condensate Pan Replacement

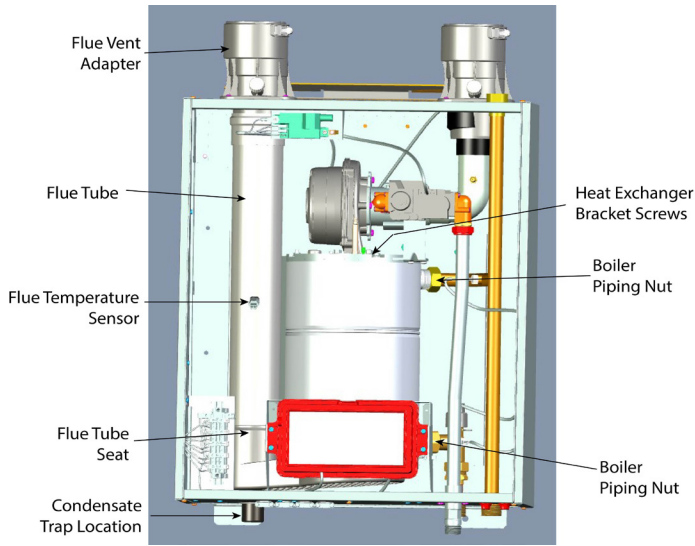

Fig. 5: Exalt 110

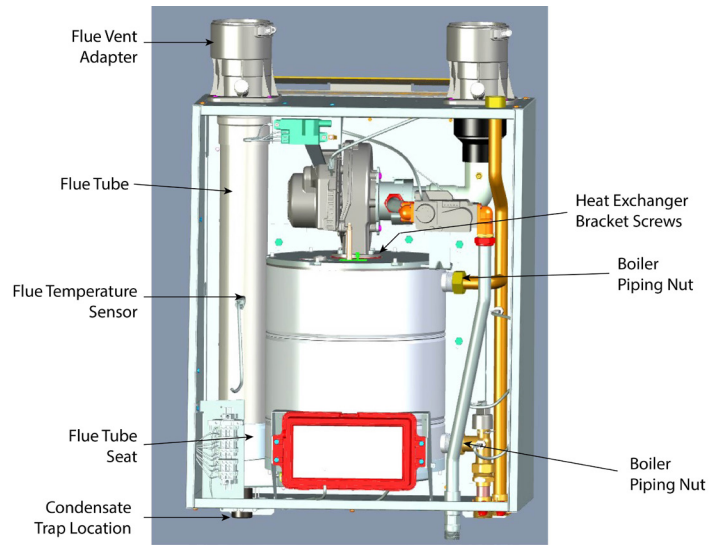

Fig. 7: Exalt 199 Solo

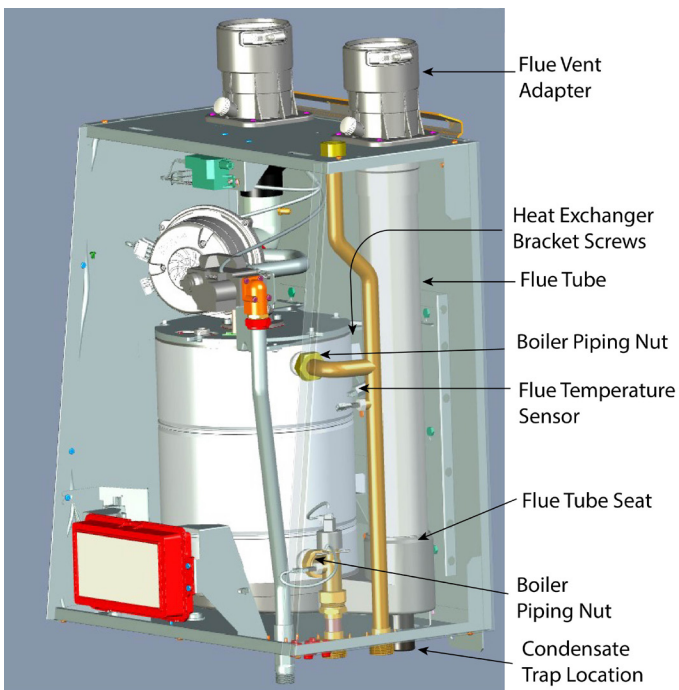

Fig. 6: Exalt 155 Solo

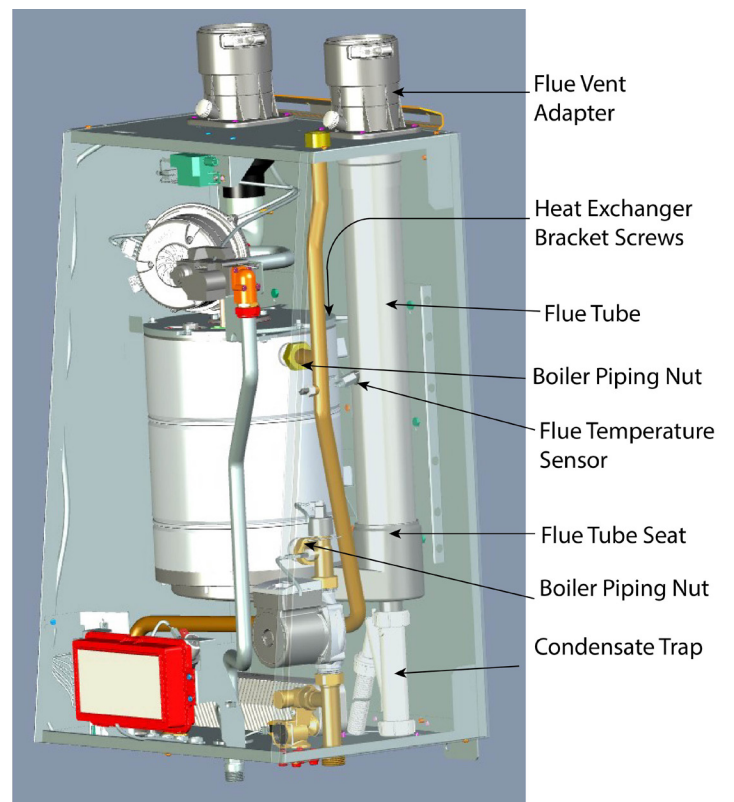

Fig. 8: Exalt 155 Combi

# Exalt Condensate Pan Replacement

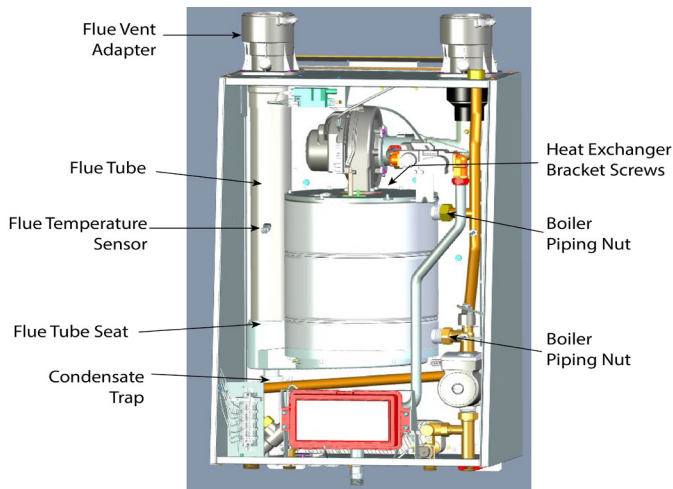

Fig. 9: Exalt 199 Combi

## 4a. Removal of Condensate Trap (Solo Models)

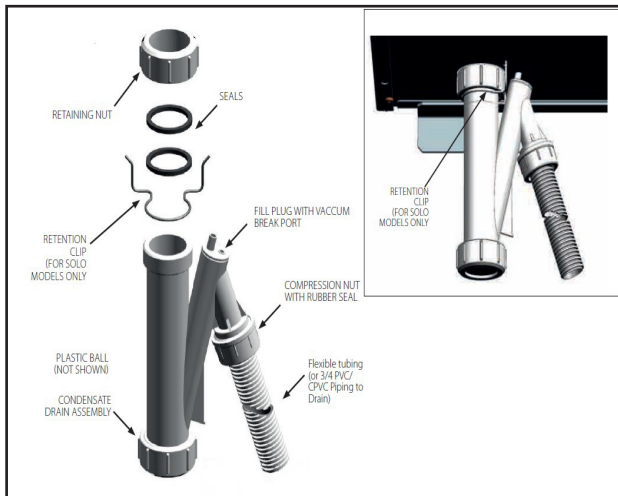

Fig. 10: Condensate Trap

1. External to the boiler cabinet, pinch and remove the retention clip securing the condensate trap. See Fig. 10.
2. Unscrew the retaining nut securing the condensate trap and pull down from nipple.
3. Pull the retaining nut and seals off the drain nipple. Do not discard the seals as they will be reused.

## 4b. Removal of Condensate Trap (Combi Models)

1. Remove the access panel on the bottom of the boiler cabinet. Do not discard the three screws as they will be reused.
2. Unscrew the retaining nut securing the condensate trap.
3. Pull the condensate trap down to disengage it from the heat exchanger.
4. Pull the retaining nut and seals off the drain nipple. Do not discard the seals as they will be reused.

## 5. Removal of Flue Tube

1. Disconnect the molex plug connected to the flue temperature sensor in the flue tube.
2. Remove the flue temperature sensor by pulling it straight out of the flue tube. Inspect the flue sensor for any damage.
3. Use a flat head screw driver to loosen the banding clamp located on the flue vent outlet adapter
4. Unscrew the four screws securing the flue vent adapter to the top jacket panel. Do not discard these screws as they will be reused.
5. Disconnect the vent piping from the flue vent adapter.
6. Twist and lift the vent adapter up to disengage from the flue tube and remove.
7. Twist and lift the flue tube up and out of the flue tube seat.
8. Remove the flue tube out of the boiler by pulling it straight up out the vent adapter hole in the top jacket panel.

## 6. Disconnect Boiler Piping

1. Loosen the two nuts securing the boiler piping to the heat exchanger. See Fig. 5 - Fig. 9.
2. Do not discard the gaskets as they will be reused.

# Exalt Condensate Pan Replacement



## 7. Removal of Heat Exchanger

1. Unscrew the two T25 Torx screws securing the heat exchanger to the back jacket panel. Do not discard these screws as they will be reused. See Fig. 11.



Fig. 11: Heat Exchanger Bracket Screws

2. Lift the heat exchanger up to disengage from the brackets on the back jacket panel. Once disengaged, remove heat exchanger from the boiler.

## 8. Remove Condensate Pan

1. Loosen and remove all nuts securing the condensate pan to the bottom of the heat exchanger. Do not discard the nuts as they will be reused.
2. Remove the condensate pan from the heat exchanger. Mark the orientation of the condensate pan on the heat exchanger.

### NOTICE

*If the condensate pan is install in the incorrect orientation, the final fit up of all the connections will not be possible and it will be necessary to remove the pan and correct the orientation.*

3. Remove and discard the gaskets in the top opening and in the flue tube seat.

## 9. Install New Condensate Pan

1. Seat the new flue tube gasket in the flue tube seat.
2. Seat the new condensate pan gasket in the recess as shown in Fig. 12 with the side with less ribs facing upward.
3. Install the condensate pan onto the bottom of the heat exchanger in the same orientation as the previous pan.

vious pan.

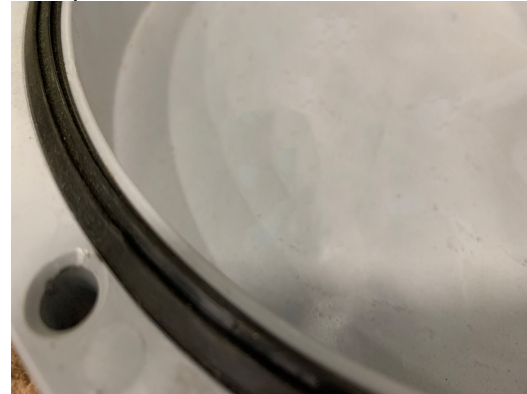

Fig. 12: Condensate Pan Gasket



**Ensure the gasket is in place before reassembly. Failure to do so can result serious injury or substantial property damage.**

4. Hand tighten all nuts on the condensate pan. Once all of the nuts are hand tight, fully torque all nuts in a star pattern.

## 10. Installation of new Heat Exchanger

1. Lift the new heat exchanger and carefully engage both brackets in the rear jacket panel. Gently tug the boiler to ensure both brackets are engaged.
2. Tighten both T25 torx screw in the top bracket. See Fig. 11.

## 11. Attach Boiler Piping

1. Reinstall the gaskets into the boiler nuts.



**Ensure the gasket is in place before reassembly. Failure to do so can result serious injury or substantial property damage.**

2. Tighten both boiler piping nuts.

## 12. Install Flue Tube

1. install the flue tube through the hole in the top

# Exalt Condensate Pan Replacement



jacket panel.

2. Push and twist the flue tube into the flue tube seat. Ensure the rubber seal is in place in the flue tube seat. Orient the flue tube so that the flue sensor is facing forward.
3. Ensure the rubber seal is in place in the top of the flue tube. Reinstall the vent outlet adapter, pushing it down firmly to secure it to the flue tube.



**Ensure the gasket is in place before reassembly. Failure to do so can result death, serious injury or substantial property damage.**

4. Reinstall the four screws to secure the vent adapter.



**Ensure the screws are in firmly installed prior to starting the boiler. Failure to do so can result death, serious injury or substantial property damage.**

5. Reconnect the vent piping to the vent outlet adapter. Tighten the banding clamp with a flat-head screwdriver to secure the vent piping to the adapter.



**Ensure the venting is tight and secure prior to start up. Failure to do so can result death, serious injury or substantial property damage.**

6. Reinstall the flue temperature sensor by pushing it into the rubber boot.
7. Plug in the molex plug into the flue sensor.

## 11a. Removal of Condensate Trap (Combi Models)

1. Install the retaining nut and both seals onto the drain nipple. See Fig. 10.
2. Push the condensate trap onto the condensate nipple as far as it will go.

3. Tighten the retaining nut to the condensate trap to secure the condensate trap.
4. Pull the condensate drain hose out the bottom of the boiler.
5. Install the access panel and tighten the three Phillips screw.

## 11b. Removal of Condensate Trap (Solo Models)

1. Push the retaining nut and both seals onto the drain nipple. See Fig. 10.
2. Push the condensate trap onto the drain nipple as far as it will go.
3. Tighten the retaining nut to the condensate trap to secure the condensate trap.
4. Pinch and install the retention clip to secure the condensate trap.

## 12. Install Burner Assembly

1. Align the burner/combustion chamber insulation with the gas valve facing the front of the boiler. See Fig. 1, Fig. 2, Fig. 3.
2. Align the bolt holes in the insulation and burner mounting plate. Carefully install the assembly into the heat exchanger, pushing the heat exchanger studs through the bolt holes.



**Ensure the burner/gas valve/igniter are not damaged. Contact IdealUSA right away if any item is damaged in any way.**

3. Reinstall the burner plate nuts. Make all nuts hand tight. Once all nuts are finger tight, torque all nuts to 44-53 in-lbs in a star pattern.
4. Place the blower gasket in place onto the burner mounting plate.
5. Place the blower/venturi assembly onto the mounting plate by sliding the two slotted holes onto the two partially installed bolts. Tighten all four 8mm

# Exalt Condensate Pan Replacement



bolts to secure the blower in place.



**Ensure the gasket is in place before reassembly. Failure to do so can result in death, serious injury or substantial property damage.**

6. Install the gaskets and tighten the gas piping nuts to the gas valve.



**Ensure the gasket is in place before reassembly. Failure to do so can result in death, serious injury or substantial property damage.**

7. Push the air inlet elbow into the venturi and vent adapter.
8. Reinstall the silicon tube onto the brass fitting on the air inlet elbow.



**Ensure the silicon tube is secure on both ends. Failure to do so may cause the boiler to malfunction and can result in death, serious injury or substantial property damage.**

9. Reconnect all wires to the igniter, gas valve, and blower.

### 13. Return to Service

1. If previously removed, reinstall the air vent at the top of the boiler.
2. Open all isolation valves to refill the boiler.
3. Carefully inspect all joints for water leaks. Tighten any loose connections.
4. Turn on gas supply to the inlet of the unit at the main manual shutoff valve to the unit. Check and test all gas connections for leaks. Repair leaks if found.



# Exalt Condensate Pan Replacement



**Do not check for gas leaks with an open flame. Use a bubble test. Failure to check for gas leaks can cause severe personal injury, death or substantial property damage.**

- Turn power to the unit "ON". Run a combustion analysis test prior to returning to service.

## 14. Combustion Test and Adjustments



*The installer MUST perform a complete combustion check to ensure the following combustion levels are met at high and low input firing rates and the burner is operating at optimum conditions.*

Table 1: Recommended Combustion Settings

		NG 110, 155	NG 199	Propane
High Fire	CO <sub>2</sub> Range	9.0 to 10.5%	8.5 to 10.5%	10.4 to 11.0%
	O <sub>2</sub> Range	4.85 to 2.15 %	5.75 to 2.15 %	5.1 to 4.2 %
	CO Max	150 ppm		200 ppm
Low Fire	CO <sub>2</sub> Range	9.0 to 10.0 %	8.5 to 10.0 %	10.4 to 11.0 %
		Lower than or equal to High Fire CO <sub>2</sub> level		
	O <sub>2</sub> Range	4.85 to 3.0 %	5.75 to 3.0 %	5.1 to 4.2 %
		Higher than or equal to High Fire CO <sub>2</sub> level		
CO Max	10 ppm			



# Exalt Condensate Pan Replacement



The combustion testing and adjustments must be performed by a qualified installer, service agency or the gas supplier. All combustion measurements must be performed with calibrated equipment to ensure proper readings and accuracy.



Failure to perform a complete combustion test at both high and low input rates may result in incomplete combustion and the production of carbon monoxide, which can cause severe personal injury, death or substantial property damage.

1. Touch simultaneously on the up and down soft keys (as high lighted by the wrench icon) for 3 seconds to access the functions for the installer. See Fig. 13.
2. Enter the installer access code "054" by using the LEFT and RIGHT buttons to select a digit and the UP and DOWN buttons to change the digit. Press the center button to enter the access code.



Fig. 13: CTRLMax Navigation Control

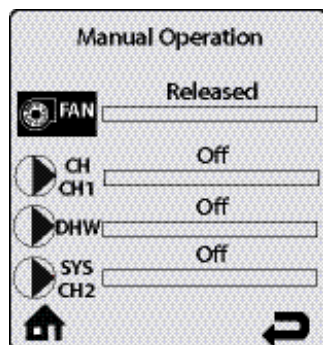

Fig. 14: Controls display

3. Press the RIGHT button to highlight the Manual Operation icon then press the OK button.

4. Press the center button while the FAN icon is highlighted to manually fire the burner and power the CH circulator. See Fig. 14

### NOTICE

An adequate CH load must be present to dissipate the heat generated during the combustion test. If an adequate CH load is not available, an indirect water heater can be used to dissipate the heat by creating a DHW call which will enable the DHW circulator.

5. Press the RIGHT button to adjust the firing rate to 100% (high fire). Hold down the RIGHT button to rapidly increase the firing rate.
6. If the combustion levels during high fire are outside the recommended combustion settings, adjust the THROTTLE SCREW using a flat-blade screwdriver as follows:

### Counter-clockwise adjustment of the THROTTLE SCREW at High Fire (100% firing rate):

Increase CO<sub>2</sub> & Decrease O<sub>2</sub>

### Clockwise adjustment of the THROTTLE SCREW at High Fire (100% firing rate):

Decrease CO<sub>2</sub> & Increase O<sub>2</sub>

7. Once the combustion level is set at high fire, manually place the boiler into low fire mode by pressing the LEFT button to adjust firing rate down to 0% (low fire).
8. If the combustion level (O<sub>2</sub> or CO<sub>2</sub>) during low fire is not within +/-0.2 of the combustion level measured at high fire, shut down the boiler and contact IdealUSA Tech Support at 856-228-3584, ext. 500

**Exalt**  
**Condensate Pan Replacement**

---

