

Engineering Submittal Data

- Distribution Manifold for (2) Gallant Solo 399 Boilers
- The Distribution Manifold Includes:
 - 3" ANSI Flange Connections with Gaskets and Hardware
 - Blind Flanges
 - 3" ANSI to 3" NPSC Flanges
 - Heavy-Duty Concrete Anchors & Bolts
 - Flexible Stainless Steel Connecting Hoses for Easy Boiler Connections
 - Boiler Communication Cable
 - System Temperature Sensor
- Primary Secondary Piping Assemblies
 - Individual Boiler Shut Off Valves
 - Individual Boiler Drain/Shut Off Valves
 - Individual Circulator Isolation Valves
- Individual Flanged Boiler Circulators
 - 3 Speed Grundfos UPS-26-99FC with Flow Check
 - Gaskets & Hardware
- Hydronic Junction for
 - System Separation
 - Air Elimination with Vent
 - Dirt Separation
 - Drain Valve
 - Insulated
 - 3" ANSI Flange Connections

Optional Equipment

- GACAS17 CSD-1 Kit (1 Kit per Boiler is Required)
 - Probe Type Low Water Cut-Off Field Wired to Boiler for Manual Reset
 - Boiler High Temperature Limit Control Field Wired to Boiler for Manual Reset
 - Drywell for Boiler High Temperature Limit Control
 - Required Pipe Fittings
- GAVKIT03 - Concentric Vent/Air Side Wall Kit (1 Kit per Boiler)
- GAVKIT02 - Stainless Steel Vent/Air Side Wall Termination Kit for 2 pipe PVC/CPVC System (1 Kit per Boiler)
- GAVTERM05 - PVC Vent/ Air Side Wall Termination Kit for 2 Pipe PVC/CPVC System (1 Kit per Boiler)
- GAVKIT04 - Two Boiler Common Vent Near Boiler Piping Kit (1 required)
- GAVTERM01 - Vertical Common Vent Termination
- GAVTERM02 - Horizontal Common Vent Termination

Specifications

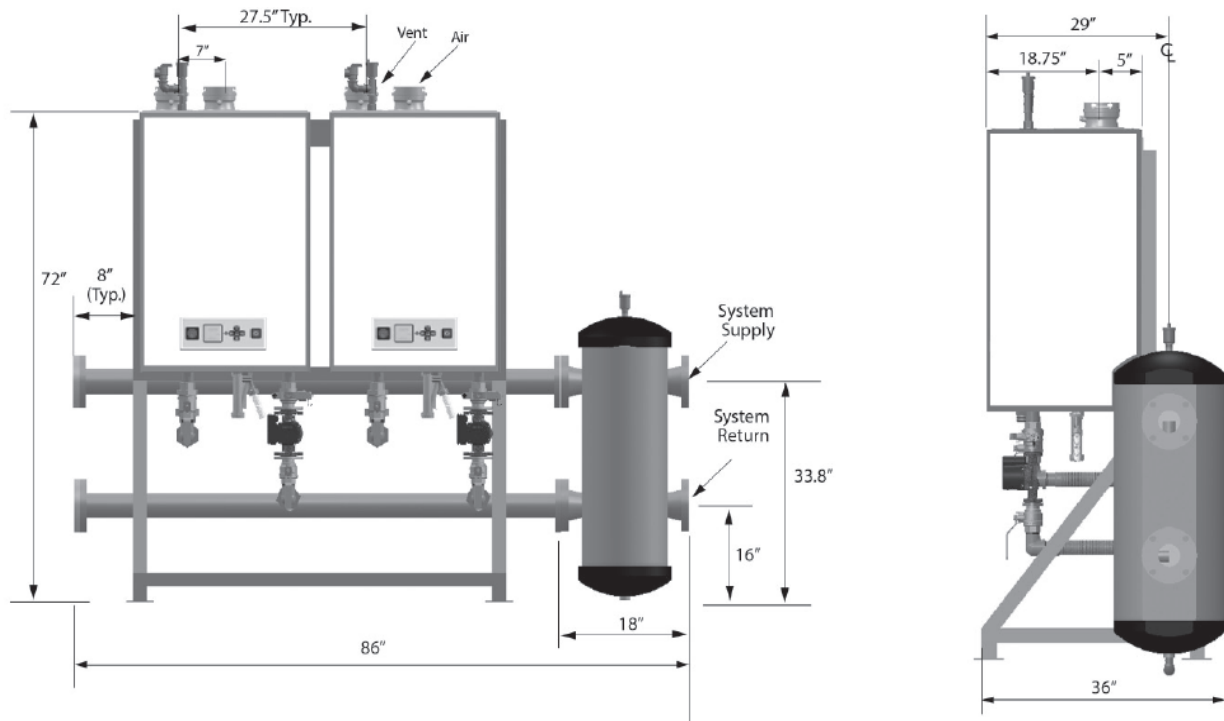

Cascade Kit P/N	# of Manifolds	# of Solo 399 Boilers	Total Input MBH Note 1	Total Output MBH Note 1 & 2	Total Net AHRI Rating MBH Note 3	Total EDR Water Ft 2 Note 4	Total Output Boiler Horse-Power	Minimum Recommended System Pipe Size Note 5	Minimum Recommended Natural Gas Header Size Note 6
CPS 800	1	2	72.5 - 798	759	660	4,399	22.7	3"	2"

Note 1: Input and output ratings are shown for sea level applications. The Gallant Solo 399 automatically derates the input at approximately 2% for every 1,000 feet of altitude. No alteration to the boiler or burner system is required.

Note 2: Gallant Solo 399 output rating is based off a thermal efficiency of 95.1%. Gallant Solo 399 combustion efficiency is 94.1%

Note 3: The AHRI rating is based on piping and pick up allowance of 1.15. This allowance should be sufficient for standard radiation requirements.

Note 4: Equivalent Direct Radiation (EDR) is based on 150 Btu/h per square foot at 170°F average supply temperature.

Note 5: Minimum recommended system iron pipe size is based on temperature differential of 20°F.

Note 6: Minimum recommended natural gas header size is based on using schedule 40 metallic pipe with 0.30" w.c. pressure drop and 100 feet of total equivalent length.

Component	Individual Water Content Gal	Individual Shipping Weight Lbs
Gallant 399	7.4	225
2 Boiler Manifold	6.6	267
Hydronic Junction	8	124

Cascade Kit P/N	Total Water Content Gal.	Total Shipping Weight Lbs
CPS 800	30	1,070

Hydronic Junction System Pressure Drop Curve

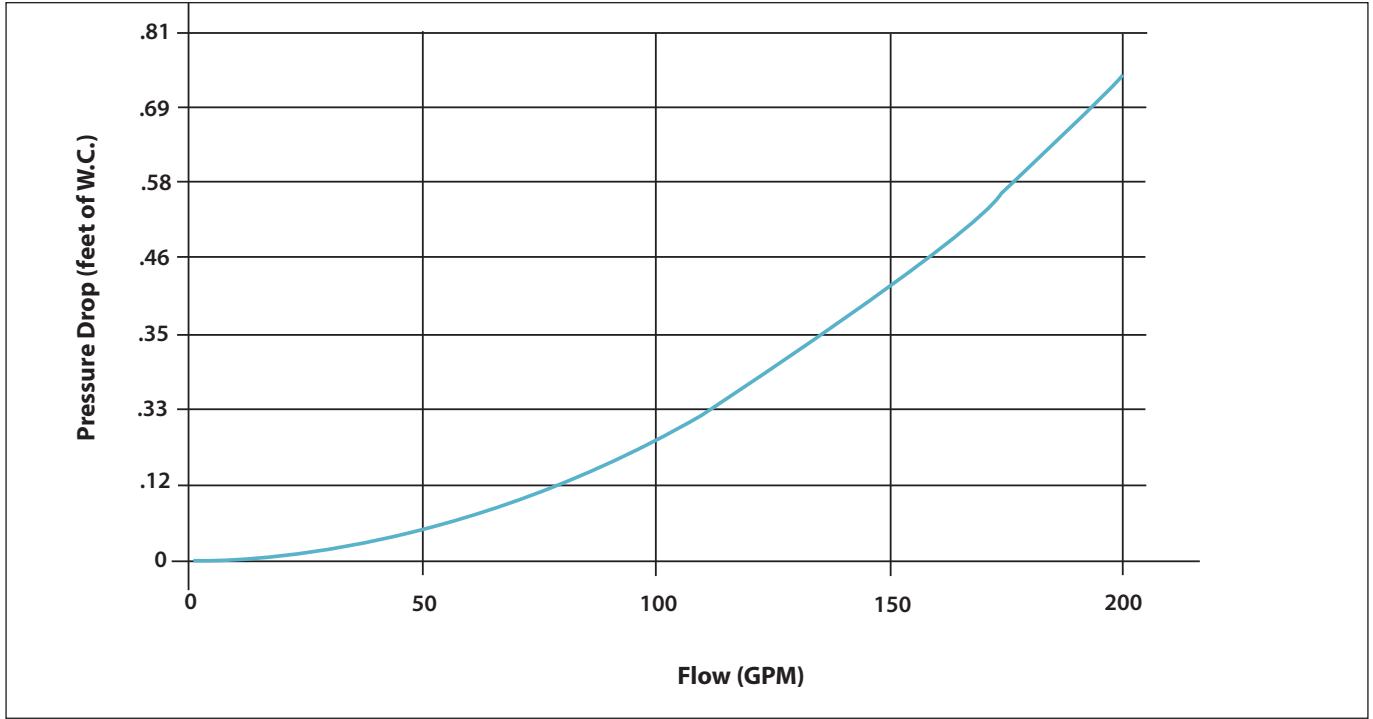

Project / Location _____	Date _____
Consulting Engineer/ Architect _____	
Mechanical Contractor _____	
Notes _____	