

# Technical submittal

Products: **Upton UF1050-3**

Project:

Customer:

Date:

- ⊗ Aluminium heat exchanger
- ⊗ 15:1 turndown ratio
- ⊗ 6 bar rated heat cell
- ⊗ 5-year heat exchanger warranty
- ⊗ 96.9% gross seasonal efficiency
- ⊗ 949.2kW output @80/60°C
- ⊗ Fits in a footprint of 700 x 1127mm
- ⊗ Passes through a standard door width
- ⊗ 36mg/kWh NOx emissions gross (natural gas)
- ⊗ Noise at maximum modulation of 60.9dba
- ⊗ Built-in controls platform with sequence control and capable of controlling up to 16 boiler modules and hot water circuits
- ⊗ British manufactured



	Boiler model	Units	UF1050-3
	No. of modules		3
Energy	Building Regulations Part L seasonal efficiency	% gross	96.9
	Building Regulations Part L seasonal efficiency	% nett	107.7
	Boiler output 80/60°C	kW	949.2
	Boiler output 50/30°C	kW	1046.7
	Boiler input gross (maximum)	kW	1082.5
	Boiler input nett (maximum)	kW	974.8
	Boiler output 80/60°C (minimum)	kW	63.3
	Boiler output 50/30°C (minimum)	kW	69.8
Water	Water content	litres	81
	System design flow rate @ 11°C ΔT rise	l/s	22.8
	Water side pressure loss @ 11°C ΔT rise	mbar	835
	System design flow rate @ 20°C ΔT rise	l/s	12.6
	Water side pressure loss @ 20°C ΔT rise	mbar	255
	Minimum operating water pressure	barg	0.5
	Maximum operating water pressure	barg	5.3
	Maximum water pressure	barg	6
	Maximum flow temperature setting	°C	85
Minimum flow temperature setting	°C	30	
Gas	Gas flow rate (maximum) (Nat gas)	m³/hr	103.1
	Nominal inlet pressure (Nat gas)	mbar	20
	Maximum inlet pressure (Nat gas)	mbar	25
Flue	Approx flue gas volume @ 72°C, 9.0% CO <sub>2</sub>	m³/hr	1629
	Maximum flue gas temperature @ 80/60°C	°C	72
	Maximum flue gas temperature @ 50/30°C	°C	42
	Pressure available at flue connection	Pa (mbar)	60 (0.6)
	NO <sub>x</sub> pond,Hs (gross) emission (0% excess oxygen, dry air) (Nat gas)	mg/kWh	36
	NO <sub>x</sub> pond (nett) emission (0% excess oxygen, dry air) (Nat gas)	mg/kWh	40
NO <sub>x</sub> Class		6	
Connection	Water flow/return connections	inches	R2-11
	Gas inlet connection pipe thread size	inches	G1¼
	Flue connection diameter (I/D)	mm	300
	Condensate trap connections (O/D)	mm	34
Electrics	Electrical supply		230V ~ 50Hz
	Power consumption - maximum boiler modulation	W	1524
	Run current (per module)	Amp	2.2
	Approx shipping weight	kg	884
	Noise emission @1m @max modulation (per module)	Max dB (A)	60.9

# Technical submittal

Products: **Upton UF1050-3**

Project:

Customer:

Date:

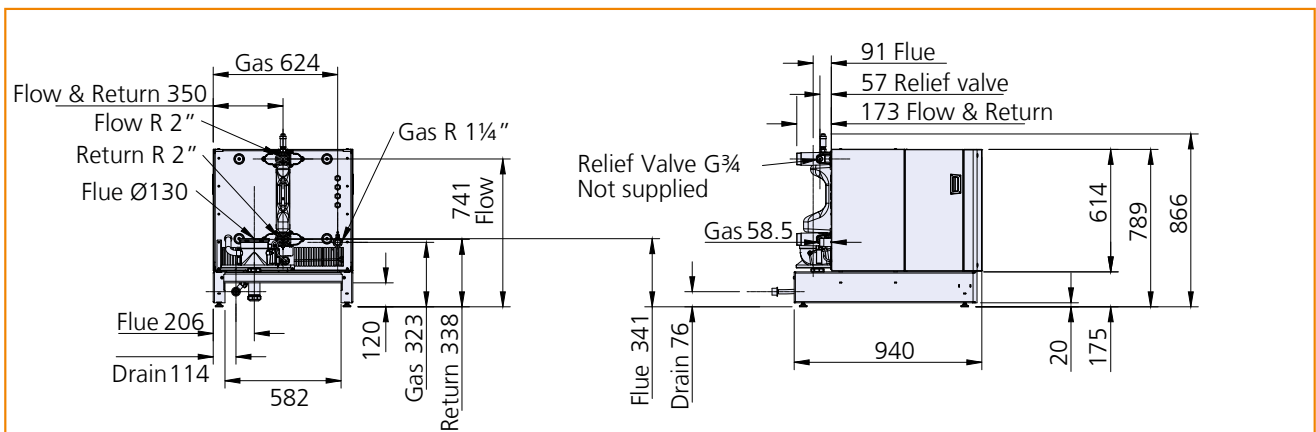
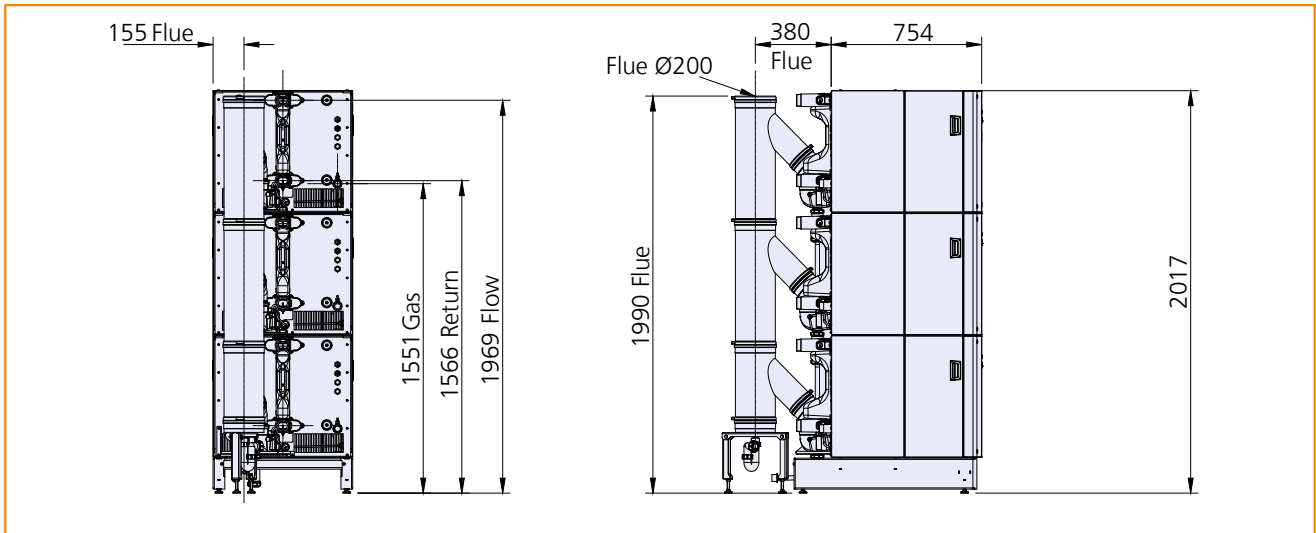
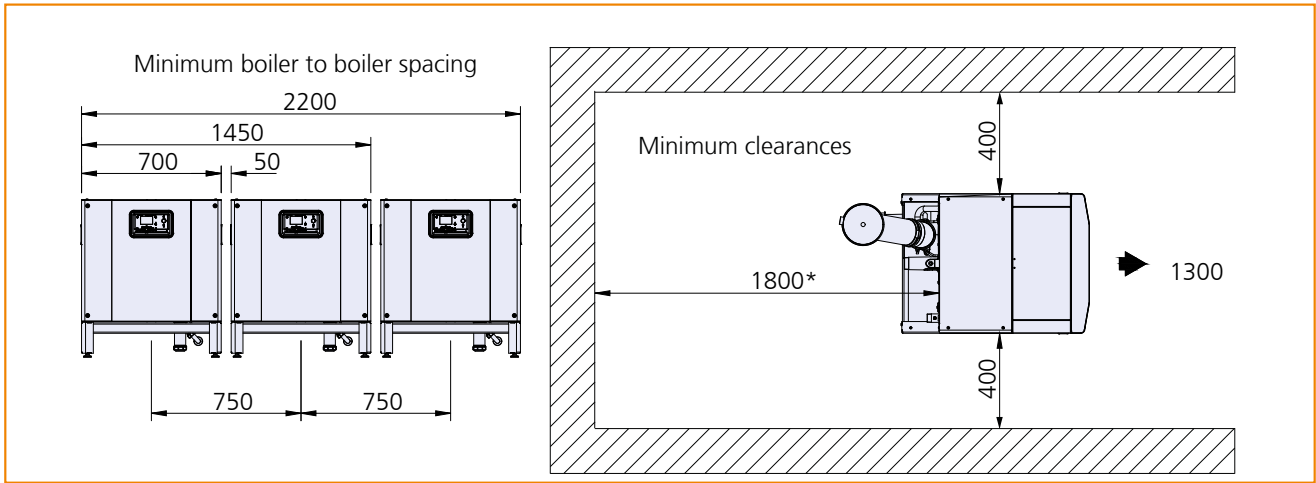

\*Note: Rear clearance required when using Hamworthy pipe kits.

All dimensions in mm unless otherwise stated.